

# SmartNode™ 4830 Serial Series

## Analog VoIP IAD



Analog VoIP IAD with V.35 or X.21 interface. The SmartNode™ 4830 Serial Series connects up to 8 phone lines, VoIP, and Internet/VPN access across the integrated broadband WAN interface. Offering bundled voice, data, and VPN services, the SmartNode IAD delivers best-in-class VoIP quality for lowest cost networking.

### Integrated Serial Uplink

ADSL2+, G.SHDSL \*\*, T1/E1, V.35/X.21 WAN access options. Two 10/100 Ethernet ports. Access router with NAT, Firewall, PPPoE, DHCP, and DynDNS.

### Full VoIP Protocol Support

SIPv2, H.323v4, T.38, fax & modem bypass, G.723, G.729, G.726, G.711, echo cancellation, silence compression, comfort noise, DTMF relay.

### Full VoIP Protocol Support

SIPv2, H.323v4, T.38, fax & modem bypass, G.723, G.729, G.726, G.711, echo cancellation, silence compression, comfort noise, DTMF relay.

### FXS, FXO, or Combinations

Up to 8 FXS ports connect to your standard telephone or PBX. 2 or 4 FXO ports allow local PSTN connections. Programmable call routing and switching.

### QoS Guaranteed Voice & Data

Quality of Service ensures voice traffic gets priority without shutting down your Ethernet LAN.

### Management & Provisioning

Web-based management, SNMP, command line interface, and auto-provisioning for automated configuration & software upgrades.

### SmartNode™ Awards

- 2011 Internet Telephony Product of the Year: SmartNode™ 4120
- 2010 Internet Telephony Product of the Year: SmartNode™ 5400
- 2009 Internet Telephony Product of the Year: SmartNode™ 4400 Series
- 2008 Internet Telephony Product of the Year: SmartNode™ 4961
- 2007 Internet Telephony Product of the Year: SmartNode™ S-DTA
- 2006 Internet Telephony Product of the Year: SmartNode™ 4960
- 2005 Internet Telephony Product of the Year: SmartNode™ 4630

Patton's SmartNode™ 4830 Serial Series IADs let you add packet voice while providing access routing with native V.35 or X.21 synchronous serial connection. Add up to 8 phone lines and combine Internet and VPN access on a single PPP or Frame-Relay based access line for the new standard in toll-bypass, remote/branch office connectivity, and enhanced carrier services.

The SN4830 Serial Series offers models with combinations of 2 to 8 analog FXS phone ports and 2 or 4 FXO ports. The dual 10/100Base-T LAN ports can be used for LAN, IPsec VPN and DMZ connections. The integrated X.21 or V.35 WAN port provides direct access to broadband networks. Like every SmartNode, the SN4830 Serial Series supports the industry standard VoIP signaling protocols SIP, H.323, T.38 Fax-Relay, plus fax and modem-bypass and is interoperable with leading softswitches and VoIP services.

Quality of Service (QoS) features include advanced voice prioritization and traffic management. DownStreamQoS™ ensures voice without interruptions even over best-effort internet connections. Packet labeling according to 802.1p, TOS and DiffServ enable integration into managed QoS networks.

The SN4830 is the solution for service providers and network integrators looking for the seamless integration of analog phones and PBXs into converged VoIP-data networks. It ensures easy setup and continuous trouble-free operation and cost effective deployment. The support of the leading VoIP signaling protocols ensures interoperability with third-party equipment and protects your investments for the future.

Visit [www.patton.com](http://www.patton.com) for more information.

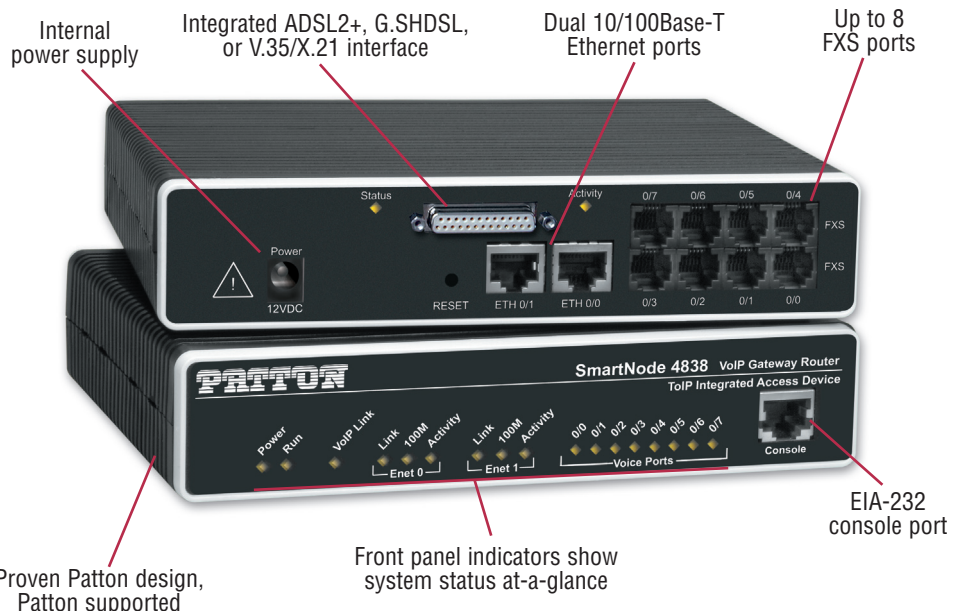

Proven Patton design,  
Patton supported

Front panel indicators show  
system status at-a-glance

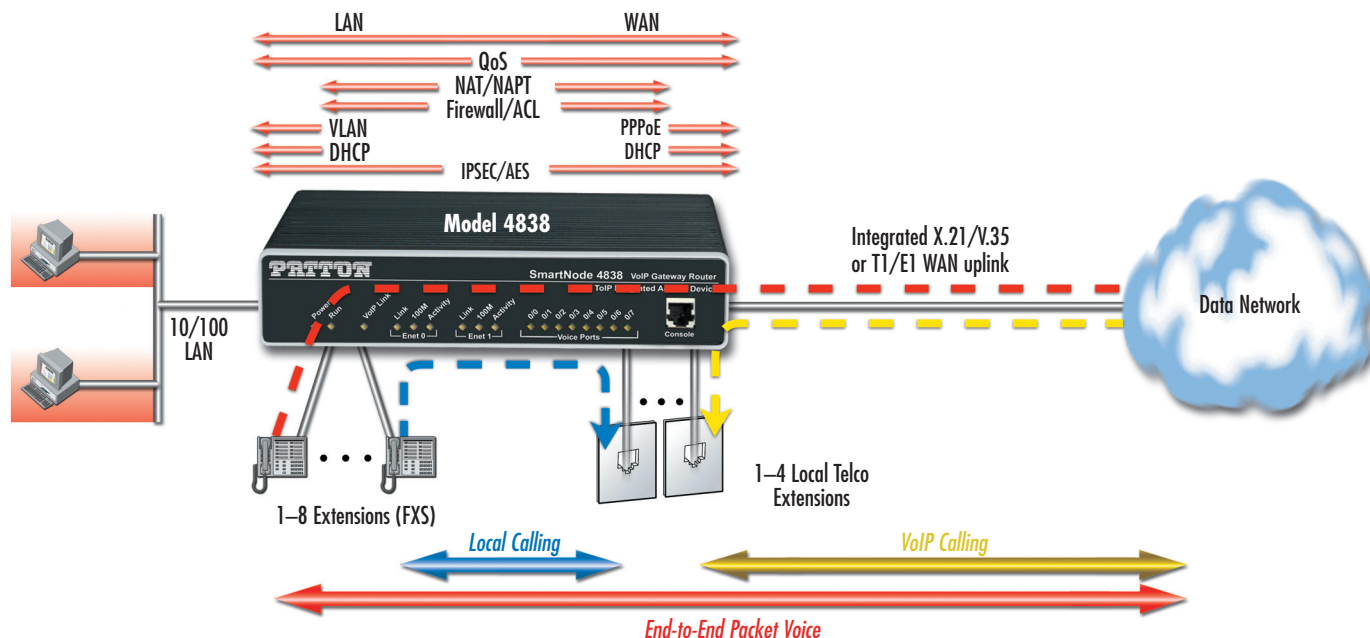

## Specifications\*

### Voice Connectivity

2-wire Loopstart, RJ-11/12 • Short haul loop 1.1 km @3REN • EuroPOTS (ETSI EG201 188) • Programmable AC impedance, feeding, and ring voltage; On-Hook Voltage 29VDC • Caller-ID Type-1/2 FSK and ITU V.23/Bell 202 generation

### IP Connectivity

Two 10/100 Ethernet ports • ADSL2+ (Annex A, B, I, J, I, M, U-R2 X.21/V.35; Frame Relay (8 PVCs); RFC1490, FRF.12 fragmentation; LMI, Q.933D, ANSI 617D, Gang of Four; PPP, PAP, CHAP, LCP, IPCP T1/E1; ITU-T G.703, ANSI T1.403; AMI, B8ZS, HDB3)

### Voice Processing

G.711 A-Law/ $\mu$ -Law (64kbps) • G.726 (ADPCM 40, 32, 24, 16 kbps) • G.723.1 (5.3 or 6.3 kbps) • G.729ab (8kbps) • G.168 echo cancellation • 8 simultaneous

ous low-bandwidth voice or T.38 fax calls • DTMF detection and generation • Carrier tone detection and generation • Silence suppression and comfort noise • Configurable dejitter buffer • Configurable tones (dial, ringing, busy) • Configurable transmit packet length • RTP/RTCP (RFC 1889)

### Fax and Modem Support

G.711 transparent fax • Fax over IP (FoIP) • T.38 Fax relay (9.6 k, 14.4 k)

### Voice Signaling

SIPv2 • H.323v4 • SIP call transfer, redirect • Overlap or en-bloc dialing • DTMF in-band, out-of-band • Configurable tones

### Call Routing & Services

Regular expression number matching • Regular expression number manipula-

tion • Least Cost Routing • Number blocking • Short-Dialing • Digit collection • Distribution-Groups and Hunt-Groups

### IP Services

IPv4 router; RIPv1, v2 (RFC 1058 and 2453) • Programmable static routes • ICMP redirect (RFC 792); Packet fragmentation • DiffServ/ToS set or queue per header bits • Packet Policing discards excess traffic • 802.1p/Q VLAN support with 4096 IDs • IPsec AH & ESP Modes • Manual Key; IKE optional • AES/DES/3DES Encryption

### Management

Industry standard CLI with local console (CRJ-45, RS-232) and remote Telnet access • TFTP configuration & firmware loading • SNMP v1 agent (MIB II and private MIB) • Built-in diag-

nostic tools (trace, debug) • Java™ Applet; HPOV Integration with NNM

### Operating Environment

Temp.: 0–40°C  
Humidity: Up to 90% (non-condensing)

### System

CPU Motorola MPC859 @ 50 MHz • Memory 16MB SDRAM/4MB Flash • Power: 100–240 VAC (50/60 Hz) • Power dissipation: 4W

### Compliance

EMC compliance: EN55022 and EN55024  
Safety compliance: EN 50950  
CE compliance  
FCC Part 15 Class A

\* Specifications subject to change without notice.

## Model Information

### Integrated V.35 WAN Interface

SN4832/JSC/EUI: 2 Port FXS  
SN4834/JSC/EUI: 4 Port FXS  
SN4836/JSC/EUI: 6 Port FXS  
SN4838/JSC/EUI: 8 Port FXS  
SN4834/2JS2JOC/EUI: 2 FXS, 2 FXO  
SN4836/4JS2JOC/EUI: 4 FXS, 2 FXO  
SN4832/JOC/EUI: 2 FXO

SN4834/JOC/EUI: 4 FXO  
SN4838/4JS4JOC/EUI: 4 FXS, 4 FXO

### Integrated X.21 WAN Interface

SN4832/JSD/EUI: 2 Port FXS  
SN4834/JSD/EUI: 4 Port FXS  
SN4836/JSD/EUI: 6 Port FXS  
SN4838/JSD/EUI: 8 Port FXS

SN4834/2JS2JOD/EUI: 2 FXS, 2 FXO  
SN4836/4JS2JOD/EUI: 4 FXS, 2 FXO  
SN4832/JOD/EUI: 2 FXO  
SN4834/JOD/EUI: 4 FXO

### Sync Serial Cables

1205-25M/35M: DB-25 male to M/34 male, for V.35 port

1205-25M/35F: DB-25 male to M/34 female, for V.35 port

EMEM216006: DB-15 male to DB-15 male, for X.21 port

### Options & Accessories

SNSW-VPN1: License key for IPsec VPN support (DES, 3DES, AES)

\*\* Call for availability.



**Patton Electronics Co.**  
7622 Rickenbacker Drive  
Gaithersburg, Maryland 20879  
USA  
Phone +1 301 975 1000  
Fax +1 301 869 9293  
E-mail [sales@patton.com](mailto:sales@patton.com)  
Web [www.patton.com](http://www.patton.com)

**PE-Inalp Networks Private Ltd**  
Old No. 14 and New No.6,  
Brahadambal Road,  
Nungambakkam High Road  
Chennai: 600 034, India  
Phone +91 44 45490395/6/7  
Fax +91 44 4549.0394  
Email [sales@patton.co.in](mailto:sales@patton.co.in)  
Web [www.patton.co.in](http://www.patton.co.in)

**Patton-Inalp Networks AG**  
Meriedweg 7  
CH-3172 Niederwangen  
Switzerland  
Phone +41 (31) 985 25 25  
Fax +41 (31) 985 25 26  
E-mail [sales@inalp.com](mailto:sales@inalp.com)  
Web [www.inalp.com](http://www.inalp.com)

07MSN4830-DS6

Patton is a registered trademark and the terms SmartNode, DownStreamQoS, and SessionRouter are trademarks of Patton Electronics Company in the United States and other countries.