

# SmartNode™ 5480 & 5490 Series Enterprise Session Border Router, IAD

## User Manual



**Important**

This is a Class A device and is not intended for use in a residential environment.

If a copper module is used, it may void the CE Certification. This product is intended for Fiber SFP modules only.

Sales Office: +1 (301) 975-1000  
Technical Support: +1 (301) 975-1007  
E-mail: [support@patton.com](mailto:support@patton.com)  
WWW: [www.patton.com](http://www.patton.com)

**Patton Electronics Company, Inc.**

7622 Rickenbacker Drive  
Gaithersburg, MD 20879 USA  
Tel: +1 (301) 975-1000  
Fax: +1 (301) 869-9293  
Support: +1 (301) 975-1007  
Web: [www.patton.com](http://www.patton.com)  
E-mail: [support@patton.com](mailto:support@patton.com)

**Trademark Statement**

The terms *SmartNode* and *SmartWare* are trademarks of Patton Electronics Company. All other trademarks presented in this document are the property of their respective owners.

**Copyright © 2013, Patton Electronics Company. All rights reserved.**

The information in this document is subject to change without notice. Patton Electronics assumes no liability for errors that may appear in this document.

**Important Information**

To use virtual private network (VPN) and/or AES/DES/3DES encryption capabilities with the SmartNode 5480 and 5490 Series, you may need to purchase additional licenses, hardware, software, network connection, and/or service. Contact [sales@patton.com](mailto:sales@patton.com) or +1 (301) 975-1000 for assistance.

**Warranty Information**

The software described in this document is furnished under a license and may be used or copied only in accordance with the terms of such license. For information about the license, see [Appendix F, "End User License Agreement"](#) on page 56 or go to [www.patton.com](http://www.patton.com).

Patton Electronics warrants all SmartNode components to be free from defects, and will—at our option—repair or replace the product should it fail within one year from the first date of the shipment.

This warranty is limited to defects in workmanship or materials, and does not cover customer damage, abuse or unauthorized modification. If the product fails to perform as warranted, your sole recourse shall be repair or replacement as described above. Under no condition shall Patton Electronics be liable for any damages incurred by the use of this product. These damages include, but are not limited to, the following: lost profits, lost savings and incidental or consequential damages arising from the use of or inability to use this product. Patton Electronics specifically disclaims all other warranties, expressed or implied, and the installation or use of this product shall be deemed an acceptance of these terms by the user.

# Summary Table of Contents

- 1 General Information ..... 13
- 2 Applications Overview ..... 22
- 3 SmartNode Installation ..... 24
- 4 Initial Configuration ..... 29
- 5 Contacting Patton for Assistance..... 34
- A Compliance Information ..... 37
- B Specifications ..... 41
- C Cabling ..... 46
- D Port Pin-outs ..... 49
- E SmartNode 5480 and 5490 Series Factory Configuration ..... 53
- F End User License Agreement ..... 56

# Table of Contents

Summary Table of Contents .....	3
Table of Contents .....	4
List of Figures .....	7
List of Tables .....	8
About This Guide .....	9
Audience.....	9
Structure.....	9
Precautions .....	10
Safety when working with electricity .....	11
General observations .....	12
Typographical Conventions Used in this Document .....	12
General conventions .....	12
<b>1 General Information .....</b>	<b>13</b>
SmartNode 5480 and 5490 Series Overview.....	14
SN5480 Series Model Codes .....	15
SN5490 Series Model Codes .....	15
CodesSmartNode 5480 and 5490 Series Rear Panels.....	16
SmartNode 5480 Rear Panel .....	16
SmartNode 5490 Rear Panel .....	17
SmartNode 5480 and 5490 Series Front Panels.....	19
SmartNode 5480 Front Panel .....	19
SmartNode 5490 Front Panel .....	20
<b>2 Applications Overview .....</b>	<b>22</b>
Introduction.....	23
Typical Application .....	23
<b>3 SmartNode Installation .....</b>	<b>24</b>
Planning the Installation.....	25
Site log .....	25
Network information .....	25
Network Diagram .....	25
IP related information .....	25
Software tools .....	26
AC Power Mains .....	26
Location and mounting requirements .....	26
Installing the SmartNode.....	26
Placing the SmartNode .....	26
Installing cables .....	26
Connecting the 10/100/1000Base-T Ethernet LAN and WAN cables .....	27
Installation cable requirements for the DSL WAN cable (SN5490 only) .....	27

Connecting the SmartNode's DSL or Fiber port (SN5490 only) .....	27
Connecting the power supply .....	28
Internal AC Power Supply .....	28
<b>4 Initial Configuration .....</b>	<b>29</b>
Introduction .....	30
1. Connecting the SmartNode to your Laptop PC .....	30
2. Configuring the Desired IP Address .....	31
Factory-default IP settings .....	31
Login .....	31
Changing the WAN IP address .....	31
3. Connecting the SmartNode to the Network .....	32
4. Loading the Configuration (optional) .....	33
Additional Information .....	33
<b>5 Contacting Patton for Assistance .....</b>	<b>34</b>
Introduction .....	35
Contact Information .....	35
Patton support headquarters in the USA .....	35
Alternate Patton support for Europe, Middle East, and Africa (EMEA) .....	35
Warranty Service and Returned Merchandise Authorizations (RMAs) .....	35
Warranty coverage .....	35
Out-of-warranty service .....	36
Returns for credit .....	36
Return for credit policy .....	36
RMA numbers .....	36
Shipping instructions .....	36
<b>A Compliance Information .....</b>	<b>37</b>
Compliance .....	38
EMC .....	38
Safety .....	38
PSTN Regulatory .....	38
FCC Part 68 (ACTA) Statement .....	39
Industry Canada Notice .....	39
CE Declaration of Conformity .....	40
Authorized European Representative .....	40
<b>B Specifications .....</b>	<b>41</b>
Data Connectivity .....	42
Voice Processing (signaling dependent) .....	42
Fax and Modem Support .....	42
Voice Signaling .....	42
IP Services .....	43
Management .....	43
System .....	43

Physical .....	43
WAN Daughter Card (if applicable).....	44
Identification of the SmartNode Devices via SNMP.....	45
<b>C Cabling .....</b>	<b>46</b>
Introduction .....	47
Console .....	47
Ethernet .....	48
<b>D Port Pin-outs .....</b>	<b>49</b>
Introduction .....	50
Console Port.....	50
Ethernet .....	50
G.SHDSL Port.....	51
EFM Port .....	52
Fiber Port .....	52
<b>E SmartNode 5480 and 5490 Series Factory Configuration .....</b>	<b>53</b>
Introduction .....	54
<b>F End User License Agreement .....</b>	<b>56</b>
End User License Agreement .....	57
1. Definitions .....	57
2. Title .....	57
3. Term .....	57
4. Grant of License .....	57
5. Warranty .....	57
6. Termination .....	58
7. Other licenses .....	58
8. SmartWare licenses .....	58

## List of Figures

1	SmartNode 5480 (left) and SmartNode 5490 (right)	14
2	SN5480 rear panel	16
3	SN5490 rear panel	17
4	SmartNode 5480 Series front panel	19
5	SN5490 rear panel	20
6	SN5480 typical application	23
7	SN5490 typical application	23
8	SN5480/5490 rear panel	28
9	SN5480/5490 Power LED	28
10	Connecting the SmartNode to your laptop PC	30
11	Connecting the SmartNode to the network	32
12	Connecting a serial terminal	47
13	Typical Ethernet straight-through cable diagram for 10/100Base-T	48
14	Typical Ethernet straight-through cable diagram for 1000Base-T	48
15	EIA-561 (RJ-45 8-pin) port	50

## List of Tables

1	General conventions	12
2	SmartNode 5480 Models	15
3	SmartNode 5490 Models	15
4	SN5480 rear panel ports	16
5	SN 5490 rear panel ports	17
6	SN5480 Front panel LEDs	19
7	SN5490 Front panel LEDs	21
8	Sample site log entries	25
9	Factory default IP address and network mask configuration	31
10	G.SHDSL Daughter Card Specifications	44
11	SmartNode Models and their Unique sysObjectID	45
12	RJ45 socket 10/100Base-T	50
13	RJ45 socket 1000Base-T	51
14	RJ-45 connector	51
15	RJ-45 connector	52



# About This Guide

---

This guide describes the SmartNode 5480 and 5490 Series hardware, installation and basic configuration. For detailed software configuration information refer to the *SmartWare Software Configuration Guide* and the available Configuration Notes.

## Audience

---

This guide is intended for the following users:

- Operators
- Installers
- Maintenance technicians

## Structure

---

This guide contains the following chapters and appendices:

- [Chapter 1](#) on page 13 provides information about SmartNode features and capabilities
- [Chapter 2](#) on page 22 contains an overview describing SmartNode operation and applications
- [Chapter 3](#) on page 24 provides hardware installation procedures
- [Chapter 4](#) on page 29 provides quick-start procedures for configuring the SmartNode
- [Chapter 5](#) on page 34 contains information on contacting Patton technical support for assistance
- [Appendix A](#) on page 37 contains compliance information for the SmartNode
- [Appendix B](#) on page 41 contains specifications for the SmartNodes
- [Appendix C](#) on page 46 provides cable recommendations
- [Appendix D](#) on page 49 describes the SmartNode's ports and pin-outs
- [Appendix E](#) on page 53 lists the factory configuration settings for the SmartNode 5480 and 5490 Series
- [Appendix F](#) on page 56 provides license information that describes acceptable usage of the software provided with the SmartNode 5480 and 5490 Series

For best results, read the contents of this guide *before* you install the SmartNode.

## Precautions

Notes, cautions, and warnings, which have the following meanings, are used throughout this guide to help you become aware of potential problems. *Warnings* are intended to prevent safety hazards that could result in personal injury. *Cautions* are intended to prevent situations that could result in property damage or impaired functioning.

**Note** A note presents additional information or interesting sidelights.



IMPORTANT

The alert symbol and IMPORTANT heading calls attention to important information.



CAUTION

The alert symbol and CAUTION heading indicate a potential hazard. Strictly follow the instructions to avoid property damage.



CAUTION

The shock hazard symbol and CAUTION heading indicate a potential electric shock hazard. Strictly follow the instructions to avoid property damage caused by electric shock.



WARNING

**The alert symbol and WARNING heading indicate a potential safety hazard. Strictly follow the warning instructions to avoid personal injury.**



WARNING

**The shock hazard symbol and WARNING heading indicate a potential electric shock hazard. Strictly follow the warning instructions to avoid injury caused by electric shock.**

## Safety When Working with Electricity



- Do not open the device when the power cord is connected. For systems without a power switch and without an external power adapter, line voltages are present within the device when the power cord is connected.
- For devices with an external power adapter, the power adapter shall be a listed *Limited Power Source*. The mains outlet that is utilized to power the device shall be within 10 feet (3 meters) of the device, shall be easily accessible, and protected by a circuit breaker in compliance with local regulatory requirements.
- For AC powered devices, ensure that the power cable used meets all applicable standards for the country in which it is to be installed.
- For AC powered devices which have 3 conductor power plugs (L1, L2 & GND or Hot, Neutral & Safety/Protective Ground), the wall outlet (or socket) must have an earth ground.
- For DC powered devices, ensure that the interconnecting cables are rated for proper voltage, current, anticipated temperature, flammability, and mechanical serviceability.
- WAN, LAN & PSTN ports (connections) may have hazardous voltages present regardless of whether the device is powered ON or OFF. PSTN relates to interfaces such as telephone lines, FXS, FXO, DSL, xDSL, T1, E1, ISDN, Voice, etc. These are known as "hazardous network voltages" and to avoid electric shock use caution when working near these ports. When disconnecting cables for these ports, detach the far end connection first.
- Do not work on the device or connect or disconnect cables during periods of lightning activity



This device is NOT intended nor approved for connection to the PSTN. It is intended only for connection to customer premise equipment.



This device contains no user serviceable parts. This device can only be repaired by qualified service personnel.



In accordance with the requirements of council directive 2002/96/EC on Waste of Electrical and Electronic Equipment (WEEE), ensure that at end-of-life you separate this product from other waste and scrap and deliver to the WEEE collection system in your country for recycling.



Always follow ESD prevention procedures when removing and replacing cards.

Wear an ESD-preventive wrist strap, ensuring that it makes good skin contact. Connect the clip to an unpainted surface of the chassis frame to safely channel unwanted ESD voltages to ground.

To properly guard against ESD damage and shocks, the wrist strap and cord must operate effectively. If no wrist strap is available, ground yourself by touching the metal part of the chassis.

### General Observations

- Clean the case with a soft slightly moist anti-static cloth
- Place the unit on a flat surface and ensure free air circulation
- Avoid exposing the unit to direct sunlight and other heat sources
- Protect the unit from moisture, vapors, and corrosive liquids

## Typographical Conventions Used in this Document

This section describes the typographical conventions and terms used in this guide.

### General Conventions

The procedures described in this manual use the following text conventions:

Table 1. General conventions

Convention	Meaning
Garamond blue type	Indicates a cross-reference hyperlink that points to a figure, graphic, table, or section heading. Clicking on the hyperlink jumps you to the reference. When you have finished reviewing the reference, click on the <b>Go to Previous View</b> button  in the Adobe® Acrobat® Reader toolbar to return to your starting point.
<b>Futura bold type</b>	Commands and keywords are in <b>boldface</b> font.
<b><i>Futura bold-italic type</i></b>	Parts of commands, which are related to elements already named by the user, are in <b>boldface italic</b> font.
<i>Italicized Futura type</i>	Variables for which you supply values are in <i>italic</i> font
Futura type	Indicates the names of fields or windows.
Garamond bold type	Indicates the names of command buttons that execute an action.
< >	Angle brackets indicate function and keyboard keys, such as <SHIFT>, <CTRL>, <C>, and so on.
[ ]	Elements in square brackets are optional.
{a   b   c}	Alternative but required keywords are grouped in braces ({ }) and are separated by vertical bars (   )
screen	Terminal sessions and information the system displays are in <i>screen font</i> .
<b>node</b>	The leading IP address or nodename of a SmartNode is substituted with <b>node</b> in <b>boldface italic</b> font.
<b>SN</b>	The leading <b>SN</b> on a command line represents the nodename of the SmartNode
#	An hash sign at the beginning of a line indicates a comment line.

**Chapter contents**

- SmartNode 5480 and 5490 Series Overview.....14
  - SN5480 Series Model Codes .....15
  - SN5490 Series Model Codes .....15
- CodesSmartNode 5480 and 5490 Series Rear Panels.....16
  - SmartNode 5480 Rear Panel .....16
  - SmartNode 5490 Rear Panel .....17
- SmartNode 5480 and 5490 Series Front Panels.....19
  - SmartNode 5480 Front Panel .....19
  - SmartNode 5490 Front Panel .....20

## SmartNode 5480 and 5490 Series Overview

The SmartNode 5480 and 5490 Series Enterprise Session Border Router enables Universal SIP Trunking and provides a single Integrated Access Device with features like IP Routing, Redundancy, Security and a SIP registrar for survivability. In addition, the SN5480/5490 enables Transcoding between two networks to most optimally support the bandwidth requirements. It is an essential device to connect Enterprise IP telephony to cost-effective SIP Trunking through the limited WAN access bandwidth. The SN5480/5490 connects to the Enterprise's LAN to an Internet telephony service provider (ITSP), creating a single conduit for multimedia components including voice, video and data.



Figure 1. SmartNode 5480 (left) and SmartNode 5490 (right)

The SmartNode 5480 and 5490 Series Enterprise Session Border Router performs the following major functions:

- **Enterprise Session Border Router with Transcoding:** Enables up to 64 transcoding sessions between codecs
- **Secure Enterprise:** Enable VPN, NAT/NAPT, Access Control Lists with Downstream QoS to ensure the most efficient use of your bandwidth
- **IP Routing:** RIP v1/v2, VRRP, policy based routing, loopback interface
- **Universal Interface support for WAN:** Support for G.SHDSL, PRI, EFM, Fiber and Gigabit Ethernet interfaces for your WAN needs
- **VPN Tunnels:** Standard IPsec with AH and ESP ensures maximum protection when traversing unsecured networks
- **Configurable Security Profiles:** Built-in IP address and IP port filtering, ACLs and DoS attack detection creates a comprehensive security environment.

### SN5480 Series Model Codes

The SmartNode 5480 Series consists of several models. They differ in the number of transcoding sessions they can support. All models come equipped with two 10/100/1000 Base-T Ethernet ports.

Table 2. SmartNode 5480 Models

Model	Transcoding Sessions
SN5480/0P/EUI	N/A
SN5480/16P/EUI	16
SN5480/32P/EUI	32
SN5480/64P/EUI	64

### SN5490 Series Model Codes

The SmartNode 5490 Series consists of several models. They differ in the number of transcoding sessions they can support and G.SHDSL, X.21, EFM or Fiber SFP options. All models come equipped with two 10/100/1000 Base-T Ethernet ports.

Table 3. SmartNode 5490 Models

Model	Transcoding Sessions	G.SHDSL Port	X.21	EFM 2 Pair	EFM 4 Pair	Fiber SFP
SN5490/32P2GS/EUI	32	✓	-	-	-	-
SN5490/32PF/EUI	32	-	-	-	-	✓
SN5490/32PD/EUI	32	-	✓	-	-	-
SN5490/32P2G/EUI	32	-	-	✓	-	-
SN5490/32P4G/EUI	32	-	-	-	✓	-
SN5490/64P2GS/EUI	64	✓	-	-	-	-
SN5490/64P2G/EUI	64	-	-	✓	-	-
SN5490/64P4G/EUI	64	-	-	-	✓	-
SN5490/64PF/EUI	64	-	-	-	-	✓

## CodesSmartNode 5480 and 5490 Series Rear Panels

### SmartNode 5480 Rear Panel

The SmartNode 5480 Series rear panel ports are described in [Table 4](#).

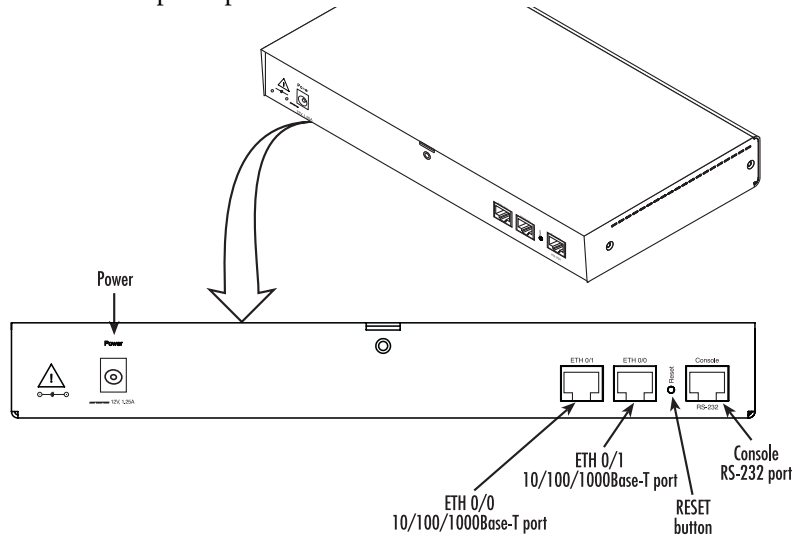

Figure 2. SN5480 rear panel

Table 4. SN5480 rear panel ports

Port	Description
<b>WAN ETH 0/0</b>	Auto-MDX Gigabit-Ethernet port, RJ-45 (see <a href="#">Figure 2</a> ), connects the unit to an Ethernet WAN device (for example, a cable modem, DSL modem, or fiber modem). Note: Only full duplex modes are supported.
<b>LAN ETH 0/1</b>	Auto-MDX Gigabit-Ethernet port, RJ-45 (see <a href="#">Figure 2</a> ), connect the unit to an Ethernet LAN (for example, a PC, printer, or wireless bridge). Note: Only full duplex modes are supported.
<b>Console</b>	Used for service and maintenance, the Console port (see <a href="#">Figure 2</a> ), an RS-232 RJ-45 connector, connects the product to a serial terminal such as a PC or ASCII terminal (also called a dumb terminal).
<b>12V DC, 1.0A</b>	Electricity supply socket. (See <a href="#">Figure 2</a> .)
<b>Reset</b>	<p>The reset button (see <a href="#">Figure 2</a>) has three functions:</p> <ul style="list-style-type: none"> <li>Restart the unit with the current startup configuration—Press (for less than 1 second) and release the <i>Reset</i> button to restart the unit with the current startup configuration.</li> <li>Restart the unit with factory default configuration—Press the <i>Reset</i> button for 5 seconds until the <i>Power</i> LED (see <a href="#">Figure 4</a> on page 19) starts blinking to restart the unit with factory default configuration.</li> <li>Restart the unit in bootloader mode (to be used only by trained SmartNode technicians)—Starting with the unit powered off, press and hold the <i>Reset</i> button as you apply power to the unit. Release the <i>Reset</i> button when the <i>Power</i> LED starts blinking so the unit will enter bootloader mode.</li> </ul>



### SmartNode 5490 Rear Panel

The SmartNode 5480 Series rear panel ports are described in [Table 5](#).

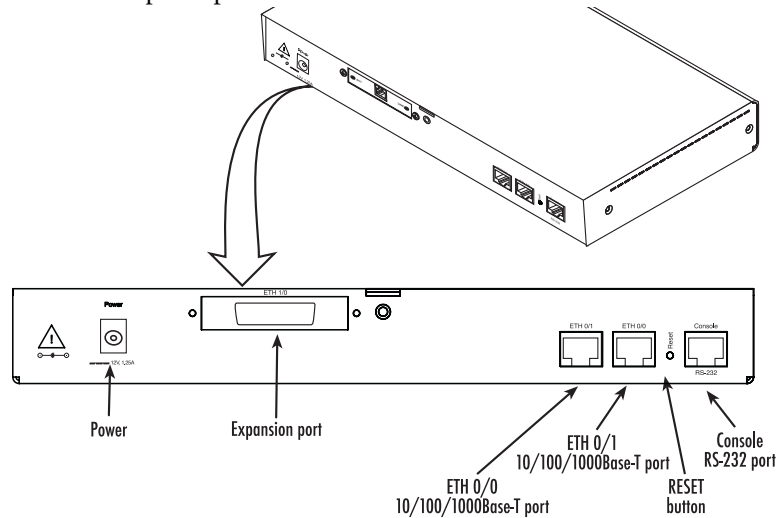

Figure 3. SN5490 rear panel

Table 5. SN 5490 rear panel ports

Port	Description
<b>WAN ETH 0/0</b>	Auto-MDX Gigabit-Ethernet port, RJ-45 (see <a href="#">Figure 2</a> ), connects the unit to an Ethernet WAN device (for example, a cable modem, DSL modem, or fiber modem). Note: Only full duplex modes are supported.
<b>LAN ETH 0/1</b>	Auto-MDX Gigabit-Ethernet port, RJ-45 (see <a href="#">Figure 2</a> ), connect the unit to an Ethernet LAN (for example, a PC, printer, or wireless bridge). Note: Only full duplex modes are supported.

Table 5. SN 5490 rear panel ports

Port	Description
<b>Expansion port</b> <b>G.SHDSL, ADSL, EFM, X.21 or SFP</b>	<p>The G.SHDSL, ADSL, EFM, X.21 or SFP LEDs are located on either side of the DSL port. ACT (when lit or blinking) shows Activity, and LINK (when lit) shows that the DSL port is connected.</p> <p><b>Note</b> <b>EFM Link Light is Different:</b>  There are two colors in the Link light on the EFM Daughterboard. Red and Green, the Green will be showing anytime ANY Link is up and traffic can flow. The Red Link will then blink to signify specific pairs that are training/not up. (Please note that if the device is configured to use less than available pairs the non-provisioned link will not be reported as down.</p> <p><b>Link (Green)OFF:</b> All pairs are DOWN, and traffic will not flow  <b>Link (Green) ON:</b> At least on pair is UP, and traffic will flow  <b>Link (Red):</b> This LED will blink with a rotating pattern to indicate ports which are still DOWN.</p> <ul style="list-style-type: none"> <li>1 BLINK - Pair 1</li> <li>2 BLINKS - Pair 2</li> <li>3 BLINKS - Pair 3</li> <li>4 BLINKS - Pair 4</li> </ul>
<b>Console</b>	Used for service and maintenance, the Console port (see <a href="#">Figure 2</a> ), an RS-232 RJ-45 connector, connects the product to a serial terminal such as a PC or ASCII terminal (also called a dumb terminal).
<b>12V DC, 1.0A</b>	Electricity supply socket. (See <a href="#">Figure 2</a> .)
<b>Reset</b>	The reset button (see <a href="#">Figure 2</a> ) has three functions: <ul style="list-style-type: none"> <li>• Restart the unit with the current startup configuration—Press (for less than 1 second) and release the <i>Reset</i> button to restart the unit with the current startup configuration.</li> <li>• Restart the unit with factory default configuration—Press the <i>Reset</i> button for 5 seconds until the <i>Power</i> LED (see <a href="#">Figure 4</a> on page 19) starts blinking to restart the unit with factory default configuration.</li> <li>• Restart the unit in bootloader mode (to be used only by trained SmartNode technicians)—Starting with the unit powered off, press and hold the <i>Reset</i> button as you apply power to the unit. Release the <i>Reset</i> button when the <i>Power</i> LED starts blinking so the unit will enter bootloader mode.</li> </ul>

## SmartNode 5480 and 5490 Series Front Panels

### SmartNode 5480 Front Panel

Figure 4 shows SmartNode 5480 Series front panel LEDs, the LED definitions are listed in Table 6.

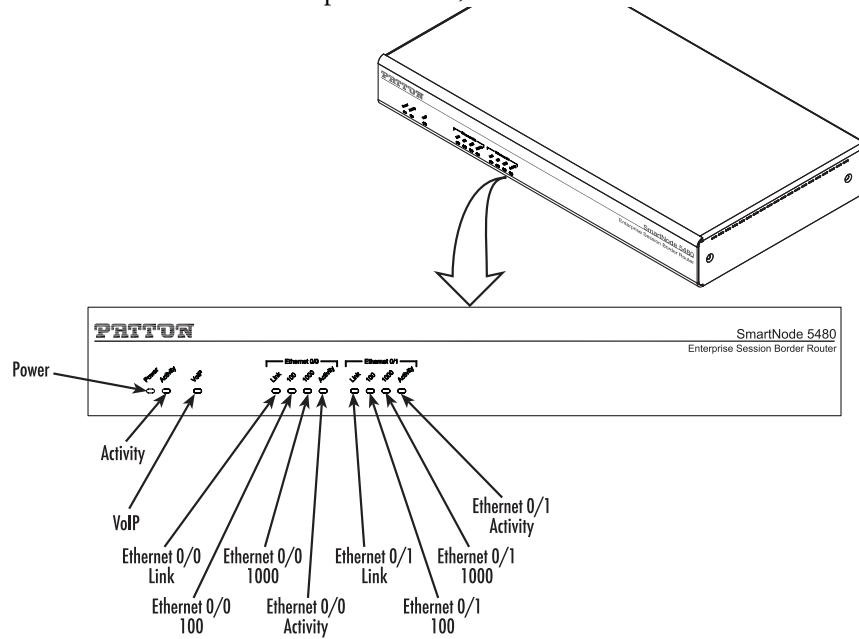

Figure 4. SmartNode 5480 Series front panel

Table 6. SN5480 Front panel LEDs

LED	Description
<b>Note</b>	If an error occurs, all LEDs will flash once per second.
<b>Power</b>	When lit, indicates power is applied.
<b>Run</b>	When lit, the unit is in normal operation. Flashes once per second during boot (startup).

Table 6. SN5480 Front panel LEDs

LED	Description
<b>VoIP Link</b>	<ul style="list-style-type: none"> <li>On indicates the gateway is registered to an H.323 gatekeeper/SIP server, or, in the case of direct routing, has at least one active VoIP connection.</li> <li>Off indicates the unit is not configured or registered, or has no active direct-routed VoIP connection.</li> <li>Flashing green indicates that the unit is attempting to register or has failed to register.</li> </ul>
<b>Ethernet Link</b>	<ul style="list-style-type: none"> <li>On when the Ethernet connection on the corresponding port has a link indication.</li> </ul>
<b>Ethernet Speed 10/100</b>	When the Ethernet Link LED is on, then: <ul style="list-style-type: none"> <li>On when the Ethernet is connected to a 100Mb network.</li> <li>Off when the Ethernet is connected to a 10Mb network.</li> </ul>
<b>Ethernet Speed 1000</b>	<ul style="list-style-type: none"> <li>On when the Ethernet is connected to a 1000Mb network.</li> </ul>
<b>Ethernet Activity</b>	<ul style="list-style-type: none"> <li>Flashes when data is received or transmitted at the corresponding Ethernet port.</li> </ul>

**SmartNode 5490 Front Panel**

Figure 5 shows SmartNode 5480 Series front panel LEDs, the LED definitions are listed in Table 7.

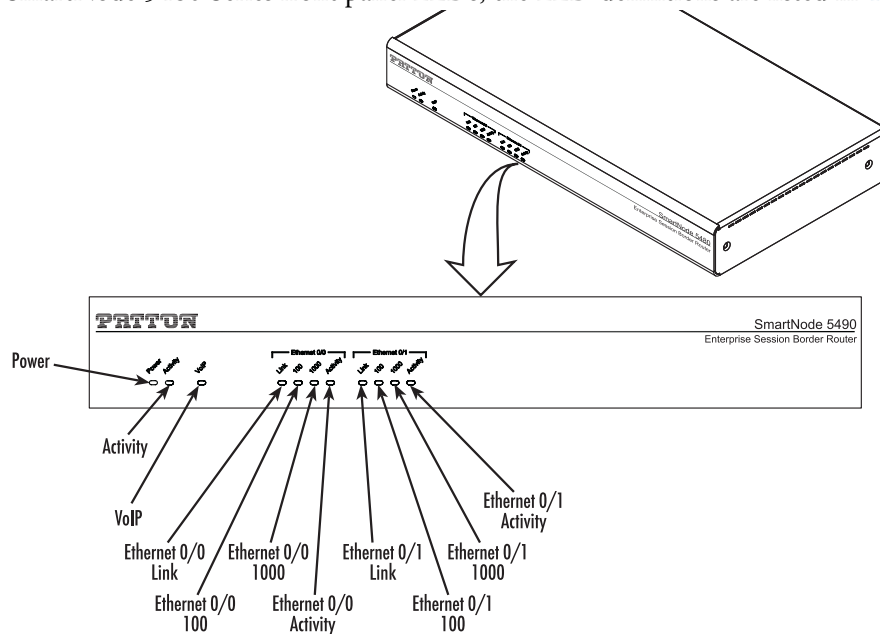

Figure 5. SN5490 rear panel

Table 7. SN5490 Front panel LEDs

LED	Description
<b>Note</b>	If an error occurs, all LEDs will flash once per second.
<b>Power</b>	When lit, indicates power is applied.
<b>Run</b>	When lit, the unit is in normal operation. Flashes once per second during boot (startup).
<b>VoIP Link</b>	<ul style="list-style-type: none"> <li>• On indicates the gateway is registered to an H.323 gatekeeper/SIP server, or, in the case of direct routing, has at least one active VoIP connection.</li> <li>• Off indicates the unit is not configured or registered, or has no active direct-routed VoIP connection.</li> <li>• Flashing green indicates that the unit is attempting to register or has failed to register.</li> </ul>
<b>Ethernet Link</b>	<ul style="list-style-type: none"> <li>• On when the Ethernet connection on the corresponding port has a link indication.</li> </ul>
<b>Ethernet Speed 10/100</b>	When the Ethernet Link LED is on, then: <ul style="list-style-type: none"> <li>• On when the Ethernet is connected to a 100Mb network.</li> <li>• Off when the Ethernet is connected to a 10Mb network.</li> </ul>
<b>Ethernet Speed 1000</b>	<ul style="list-style-type: none"> <li>• On when the Ethernet is connected to a 1000Mb network.</li> </ul>
<b>Ethernet Activity</b>	<ul style="list-style-type: none"> <li>• Flashes when data is received or transmitted at the corresponding Ethernet port.</li> </ul>
<b>G.SHDSL ACT</b> (Rear panel - SN5490)	<ul style="list-style-type: none"> <li>• Flashes when data is received or transmitted</li> <li>• Off = No activity</li> </ul>
<b>Expansion LINK</b> (Rear panel - SN5490) <b>*G.SHDSL, ADSL, SFP or X.21</b>	<ul style="list-style-type: none"> <li>• On when the connection on the corresponding port has a link indication.</li> <li>• Off = No connection</li> </ul>

**Chapter contents**

Introduction .....23  
Typical Application .....23

## Introduction

Patton's SmartNode VoIP Enterprise Session Border Routers deliver the features you need for advanced multi-service voice and data network applications. They combine high quality voice-over-IP with powerful *quality of service* routing functions to build professional and reliable VoIP and data networks. This chapter describes typical applications for which this SmartNode is uniquely suited.

**Note** Detailed configuration information for SmartNode applications can be found online at [www.patton.com/smartnode](http://www.patton.com/smartnode).

## Typical Application

The SN5480/5490 enables Universal SIP Trunking and provides a single Integrated Access Device with features like IP Routing, Redundancy, Security and a SIP registrar for survivability.

In addition, the SN5480/5490 enables Transcoding between two networks to most optimally support the bandwidth requirements. E.g. The internal of the network (LAN) could function on G.711 and the WAN side could then be on G.729 enabled by transcoding.

By using two SN5480/5490 with VRRP enabled an Enterprise could connect to two ITSP and provide for failover incase the primary SIP provider trunk has a problem.

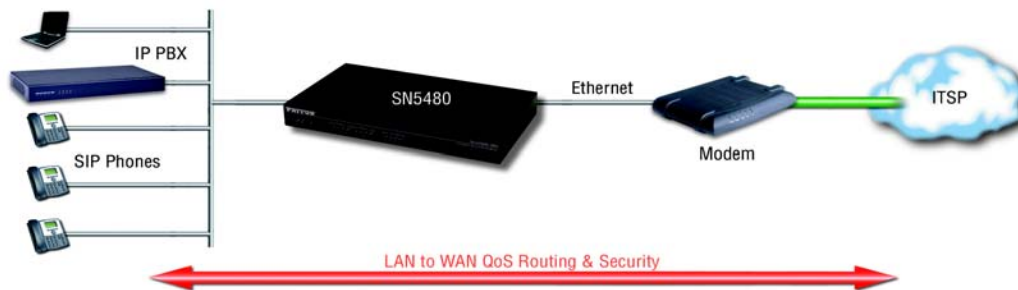

Figure 6. SN5480 typical application



Figure 7. SN5490 typical application

## Chapter 3 **SmartNode Installation**

### **Chapter contents**

Planning the Installation.....	25
Site Log .....	25
Network Information .....	25
Network Diagram .....	25
IP Related Information .....	25
Software Tools .....	26
AC Power Mains .....	26
Location and Mounting Requirements .....	26
Installing the SmartNode.....	26
Placing the SmartNode .....	26
Installing Cables .....	26
Connecting the 10/100/1000Base-T Ethernet LAN and WAN cables .....	27
Installation cable requirements for the DSL WAN cable (SN5490 only) .....	27
Connecting the SmartNode's DSL or Fiber port (SN5490 only) .....	27
Connecting the power supply .....	28



## Planning the Installation

Before installing the SmartNode, the following tasks should be completed:

- Create a **network diagram** (see section “[Network information](#)” on page 25)
- Gather **IP related information** (see section “[IP related information](#)” on page 25 for more information)
- Install the hardware and software needed to configure the SmartNode. (See section “[Software tools](#)” on page 26)
- Verify **power source reliability** (see section “[Connecting the power supply](#)” on page 28).

After you have finished preparing for SmartNode installation, go to section “[Installing the SmartNode](#)” on page 26 to install the device.

### Site Log

Patton recommends that you maintain a site log to record all actions relevant to the system, if you do not already keep such a log. Site log entries should include information such as listed in [Table 8](#).

Table 8. Sample site log entries

Entry	Description
<b>Installation</b>	Make a copy of the installation checklist and insert it into the site log
<b>Upgrades and maintenance</b>	Use the site log to record ongoing maintenance and expansion history
<b>Configuration changes</b>	Record all changes and the reasons for them
<b>Maintenance</b>	Schedules, requirements, and procedures performed
<b>Comments</b>	Notes, and problems
<b>Software</b>	Changes and updates to SmartWare software

### Network Information

Network connection considerations that you should take into account for planning are provided for several types of network interfaces are described in the following sections.

#### Network Diagram

Draw a network overview diagram that displays all neighboring IP nodes, connected elements and telephony components.

#### IP Related Information

Before you can set up the basic IP connectivity for your SmartNode, you should have the following information:

- IP addresses used for Ethernet LAN and WAN ports
- Subnet mask used for Ethernet LAN and WAN ports

- IP addresses of central H.323 gatekeeper (if used)
- IP addresses and/or URL of SIP servers or Internet telephony services (if used)
- Login and password for PPPoE Access
- Login and password for SIP or H.323 based telephony services
- IP addresses of central TFTP server used for configuration upload and download (optional)

### Software Tools

You will need a PC (or equivalent) with Windows Telnet or a program such as *Tera Term Pro Web* to configure the software on your SmartNode.

### AC Power Mains

If you suspect that your AC power is not reliable, for example if room lights flicker often or there is machinery with large motors nearby, have a qualified professional test the power. Patton recommends that you include an uninterruptible power supply (UPS) in the installation to ensure that VoIP service is not impaired if the power fails. Refer to “Connecting the power supply” on page 28.

### Location and Mounting Requirements

The SmartNode is intended to be placed on a desktop or similar sturdy, flat surface that offers easy access to the cables. Allow sufficient space at the rear of the chassis for cable connections. Additionally, you should consider the need to access the unit for future upgrades and maintenance.

**Note** Under the rack mount option, the chassis can be equipped with rack mount ears that allow for use in a 19” rack.

## Installing the SmartNode

SmartNode hardware installation consists of the following:

- Placing the device at the desired installation location (see section “Placing the SmartNode” on page 26)
- Connecting the interface and power cables (see section “Installing cables”)

When you finish installing the SmartNode, go to chapter 4, “Initial Configuration” on page 29.

### Placing the SmartNode

Place the unit on a desktop or similar sturdy, flat surface that offers easy access to the cables. The unit should be installed in a dry environment with sufficient space to allow air circulation for cooling.

**Note** For proper ventilation, leave at least 2 inches (5 cm) to the left, right, front, and rear of the unit.

### Installing Cables



WARNING

**Do not work on the system or connect or disconnect cables during periods of lightning activity.**

Connect the cables in the following order:



The interconnecting cables shall be acceptable for external use and shall be rated for the proper application with respect to voltage, current, anticipated temperature, flammability, and mechanical serviceability.

1. Connect the 10/100/1000Base-T Ethernet LAN and WAN (see section “[Connecting the 10/100/1000Base-T Ethernet LAN and WAN cables](#)” on page 27)
2. If applicable, connect the DSL WAN port (see section “[Installation cable requirements for the DSL WAN cable \(SN5490 only\)](#)” on page 27)
3. Connect the power mains cable (see section “[Connecting the power supply](#)” on page 28)

#### *Connecting the 10/100/1000Base-T Ethernet LAN and WAN cables*

The SmartNode has automatic MDX (auto-crossover) detection and configuration on all Ethernet ports. Any of the ports can be connected to a host or hub/switch with a straight-through or cross-over wired cable.

1. Connect to the subscriber port of the broadband access modem (DSL, cable, WLL) to *ETH 0/0*.

**Note** The SmartNode Ethernet ports operate in Full Duplex mode only. Do not connect to Half Duplex ports. For best results, use auto-negotiation. Auto negotiation is mandatory when using 1000BaseT (Gigabit) Ethernet.

2. Connect port ETH 0/1 to your LAN.

For details on the Ethernet port pinout and cables, refer to [Appendix C, “Cabling”](#) on page 46 and [Appendix D, “Port Pin-outs”](#) on page 49.

#### *Installation cable requirements for the DSL WAN cable (SN5490 only)*

The SmartNode Model 5490 comes with a universal option for a G.SHDSL, ADSL or EFM interface. Use a straight-through RJ-11 cable to connect the G.SHDSL port.

#### *Connecting the SmartNode’s DSL or Fiber port (SN5490 only)*

The SmartNode Model 5490 comes with an option for a SFP for Fiber WAN module. For details about the tested and compatible SFP modules please refer to <http://www.patton.com/products/sfpmodules.asp>.

### Connecting the power supply

The 5400 has the option of an internal or external [Internal AC Power Supply](#), see [Figure 8](#).

#### Internal AC Power Supply.



- Do not connect power to the AC Mains at this time.
- There are no user-serviceable parts in the power supply section of the Model 5400. Contact Patton Electronics Technical support at (301)975-1007, via our web site at <http://www.patton.com>, or by e-mail at [support@patton.com](mailto:support@patton.com), for more information.
- The internal power supply automatically adjusts to accept an input voltage from 100 to 240 VAC (50/60 Hz). Verify that the proper voltage is present before plugging the power cord into the receptacle. Failure to do so could result in equipment damage.

1. Insert the female end of the AC power to the mains port.

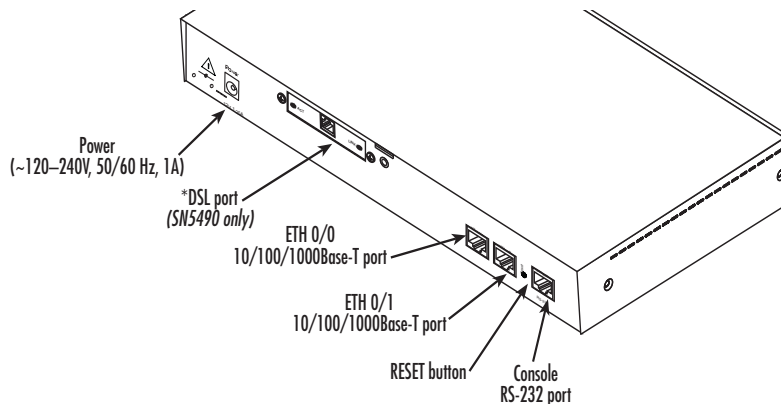

Figure 8. SN5480/5490 rear panel

2. Verify that the AC power cord included with your SmartNode is compatible with local standards. If it is not, refer to [“Contacting Patton for Assistance”](#) on page 34 to find out how to replace it with a compatible power cord.
3. Connect the male end of the AC power cord to an appropriate AC power outlet.

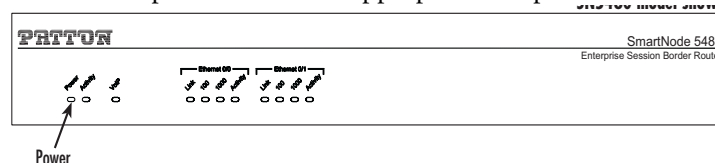

Figure 9. SN5480/5490 Power LED

4. Verify that the green *Power* LED is lit (see [Figure 9](#)).

## Chapter 4 **Initial Configuration**

### **Chapter contents**

Introduction .....	30
1. Connecting the SmartNode to Your Laptop PC .....	30
2. Configuring the Desired IP Address .....	31
Factory-default IP Settings .....	31
Login .....	31
Changing the WAN IP Address .....	31
3. Connecting the SmartNode to the Network .....	32
4. Loading the Configuration (optional) .....	33
Additional Information .....	33

## Introduction

This chapter leads you through the basic steps to set up a new SmartNode and to download a configuration. Setting up a new SmartNode consists of the following main steps:

**Note** If you haven't already installed the SmartNode, refer to chapter 3, “SmartNode Installation” on page 24.

- Connecting the SmartNode to your laptop PC
- Configuring the desired IP address
- Connecting the SmartNode to the network
- Loading the configuration (optional)

### 1. Connecting the SmartNode to Your Laptop PC

First the SmartNode must be connected to the mains power supply with the power cable. Wait until the *Power* LED stops blinking and stays lit constantly. Now the SmartNode is ready.



The interconnecting cables shall be acceptable for external use and shall be rated for the proper application with respect to voltage, current, anticipated temperature, flammability, and mechanical serviceability.

The SmartNode 5480 and 5490 Series is equipped with Auto-MDX Ethernet ports, so you can use straight-through cables for host or hub/switch connections (see [Figure 10](#)).

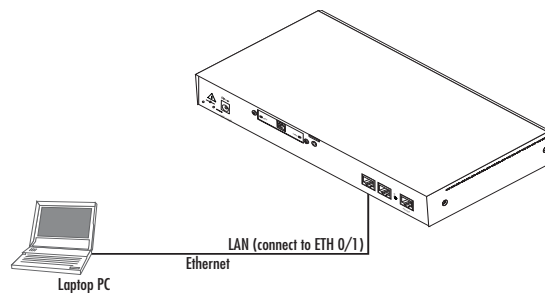

Figure 10. Connecting the SmartNode to your laptop PC

The SmartNode comes with a built-in DHCP server to simplify configuration. Therefore, to automatically configure the PC for IP connectivity to the SmartNode, the laptop PC must be configured for DHCP. The SmartNode will provide the PC with an IP address. You can check the connection to the SmartNode by executing the ping command from the PC command window as follows:

```
ping 192.168.1.1
```

## 2. Configuring the Desired IP Address

### Factory-default IP Settings

The factory default configuration for the Ethernet interface IP addresses and network masks are listed in Table 9. Both Ethernet interfaces are activated upon power-up. LAN interface *ETH 0/1 (LAN)* provides a default DHCP server, the WAN interface uses DHCP client to automatically assign the IP address and network mask.

Table 9. Factory default IP address and network mask configuration

	IP Address	Network Mask
<b>WAN interface Ethernet 0 (ETH 0/0)</b>	DHCP	DHCP
<b>LAN interface Ethernet 1 (ETH 0/1)</b>	192.168.1.1	255.255.255.0
<b>DHCP address range</b>	192.168.1.10–192.168.1.99	255.255.255.0

If these addresses match with those of your network, go to section “3. Connecting the SmartNode to the Network” on page 32. Otherwise, refer to the following sections to change the addresses and network masks.

### Login

To access the SmartNode, start the Telnet application. Type the default IP address for the SmartNode into the address field: **192.168.1.1**. Accessing your SmartNode via a Telnet session displays the login screen. Type the factory default login: *administrator* and leave the password empty. Press the *Enter* key after the password prompt.

```
login:administrator
password: <Enter>
192.168.1.1>
```

After you have successfully logged in you are in the operator execution mode, indicated by > as command line prompt. With the commands *enable* and *configure* you enter the configuration mode.

```
192.168.1.1>enable
192.168.1.1#configure
192.168.1.1(cfg)#
```

### Changing the WAN IP Address

Select the context IP mode to configure an IP interface.

```
192.168.1.1(cfg)#context ip router
192.168.1.1(ctx-ip) [router]#
```

Now you can set your IP address and network mask for the interface *ETH 0/0 (WAN)*. Within this example a network 172.16.1.0/24 address is assumed. The IP address in this example is set to 172.16.1.99 (you should set this the IP address given to you by your network provider).

```
192.168.1.1(ctx-ip) [router] #interface WAN
192.168.1.1(if-ip) [WAN] #ipaddress 172.16.1.99 255.255.255.0
2002-10-29T00:09:40 : LOGINFO      : Link down on interface WAN.
2002-10-29T00:09:40 : LOGINFO      : Link up on interface WAN.
172.16.1.99(if-ip) [WAN] #
```

Copy this modified configuration to your new start-up configuration. This will store your changes in non-volatile memory. Upon the next start-up the system will initialize itself using the modified configuration.

```
172.16.1.99(if-ip) [WAN] #copy running-config startup-config
172.16.1.99(if-ip) [WAN] #
```

The SmartNode can now be connected to your network.

### 3. Connecting the SmartNode to the Network

In general, the SmartNode will connect to the network via the *WAN (ETH 0/0)* port. This enables the SmartNode to offer routing services to the PC hosts on *LAN (ETH 0/1)* port. The SmartNode 5480 and 5490 Series is equipped with Auto-MDX Ethernet ports, so you can use straight-through or crossover cables for host or hub/switch connections (see [Figure 11](#)).



The interconnecting cables shall be acceptable for external use and shall be rated for the proper application with respect to voltage, current, anticipated temperature, flammability, and mechanical serviceability.

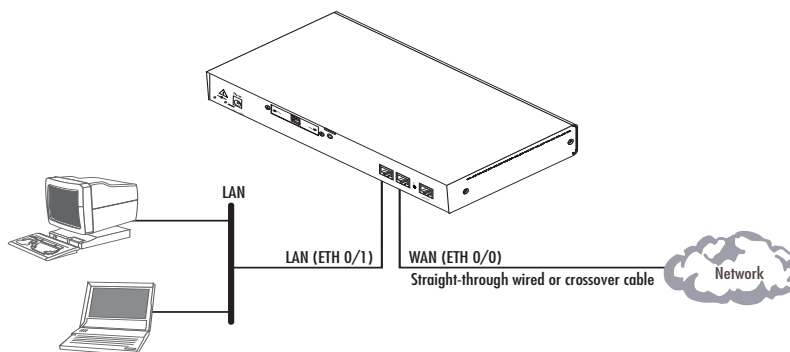

Figure 11. Connecting the SmartNode to the network

You can check the connection with the ping command from the SmartNode to another host on the network.

```
172.16.1.99(if-ip) [WAN] #ping <IP Address of the host>
```

**Note** If the WAN address is *not* set to DHCP, to ping a device outside your local LAN you must first configure the default gateway. (For information on configuring the default gateway, refer to section “Set IP addresses” in Appendix C, “Command Summary” of the *SmartNode Series SmartWare Software Configuration Guide*.)



## 4. Loading the Configuration (optional)

Patton provides a collection of configuration templates on the support page at [www.patton.com/smartnode](http://www.patton.com/smartnode)—one of which may be similar enough to your application that you can use it to speed up configuring the SmartNode. Simply download the configuration note that matches your application to your PC. Adapt the configuration as described in the configuration note to your network (remember to modify the IP address) and copy the modified configuration to a TFTP server. The SmartNode can now load its configuration from this server.

**Note** If your application is unique and not covered by any of Patton's configuration templates, you can manually configure the SmartNode instead of loading a configuration file template. In that case, refer to the *SmartNode Series SmartWare Software Configuration Guide* for information on configuring the SmartNode device.

In this example we assume the TFTP server on the host with the IP address 172.16.1.11 and the configuration named *SN.cfg* in the root directory of the TFTP server.

```
172.16.1.99(if-ip) [WAN] #copy tftp://172.16.1.11/SN.cfg startup-config
Download...100%
172.16.1.99(if-ip) [WAN] #
```

After the SmartNode has been rebooted the new startup configuration will be activated.



When you issue the **reload** command, the SmartNode will ask if you want to copy the running configuration to the startup configuration. Since you just downloaded a configuration file to the startup configuration you must answer this question with **NO**. Otherwise, the downloaded configuration will be overwritten and lost!

```
172.16.1.99(if-ip) [WAN] #reload
Running configuration has been changed.
Do you want to copy the 'running-config' to the 'startup-config'?
Press 'yes' to store, 'no' to drop changes : no
Press 'yes' to restart, 'no' to cancel : yes
The system is going down
```

## Additional Information

For detailed information about configuring and operating guidance, set up procedures, and troubleshooting, refer to the *SmartNode Series SmartWare Software Configuration Guide* available online at [www.patton.com/manuals](http://www.patton.com/manuals).

**Chapter contents**

- Introduction .....35
- Contact Information .....35
  - Patton Support Headquarters in the USA .....35
  - Alternate Patton Support for Europe, Middle East, and Africa (EMEA) .....35
- Warranty Service and Returned Merchandise Authorizations (RMAs).....35
  - Warranty Coverage .....35
    - Out-of-warranty service .....36
    - Returns for credit .....36
    - Return for credit policy .....36
  - RMA Numbers .....36
  - Shipping instructions .....36

## Introduction

---

This chapter contains the following information:

- “Contact Information”—describes how to contact Patton technical support for assistance.
- “Warranty Service and Returned Merchandise Authorizations (RMAs)”—contains information about the warranty and obtaining a return merchandise authorization (RMA).

## Contact Information

---

Patton Electronics offers a wide array of free technical services. If you have questions about any of our other products we recommend you begin your search for answers by using our technical knowledge base. Here, we have gathered together many of the more commonly asked questions and compiled them into a searchable database to help you quickly solve your problems.

### **Patton Support Headquarters in the USA**

- Online support: available at [www.patton.com](http://www.patton.com)
- E-mail support: e-mail sent to [support@patton.com](mailto:support@patton.com) will be answered within 1 business day
- Telephone support: standard telephone support is available five days a week—from 8:00 am to 5:00 pm EST (1300 to 2200 UTC/GMT)—by calling +1 (301) 975-1007
- Fax: +1 (301) 869-9293

### **Alternate Patton Support for Europe, Middle East, and Africa (EMEA)**

- Online support: available at [www.patton-inalp.com](http://www.patton-inalp.com)
- E-mail support: e-mail sent to [support@patton-inalp.com](mailto:support@patton-inalp.com) will be answered within 1 business day
- Telephone support: standard telephone support is available five days a week—from 9:00 am to 5:30 pm MET (0800 to 1630 UTC/GMT)—by calling +41 (0)31 985 25 55
- Fax: +41 (0)31 985 25 26

## Warranty Service and Returned Merchandise Authorizations (RMAs)

---

Patton Electronics is an ISO-9001 certified manufacturer and our products are carefully tested before shipment. All of our products are backed by a comprehensive warranty program.

**Note** If you purchased your equipment from a Patton Electronics reseller, ask your reseller how you should proceed with warranty service. It is often more convenient for you to work with your local reseller to obtain a replacement. Patton services our products no matter how you acquired them.

### **Warranty Coverage**

Our products are under warranty to be free from defects, and we will, at our option, repair or replace the product should it fail within one year from the first date of shipment. Our warranty is limited to defects in workmanship or materials, and does not cover customer damage, lightning or power surge damage, abuse, or unauthorized modification.

### *Out-of-warranty service*

Patton services what we sell, no matter how you acquired it, including malfunctioning products that are no longer under warranty. Our products have a flat fee for repairs. Units damaged by lightning or other catastrophes may require replacement.

### *Returns for credit*

Customer satisfaction is important to us, therefore any product may be returned with authorization within 30 days from the shipment date for a full credit of the purchase price. If you have ordered the wrong equipment or you are dissatisfied in any way, please contact us to request an RMA number to accept your return. Patton is not responsible for equipment returned without a Return Authorization.

### *Return for credit policy*

- **Less than 30 days:** No Charge. Your credit will be issued upon receipt and inspection of the equipment.
- **30 to 60 days:** We will add a 20% restocking charge (crediting your account with 80% of the purchase price).
- **Over 60 days:** Products will be accepted for repairs only.

### **RMA Numbers**

RMA numbers are required for all product returns. You can obtain an RMA by doing one of the following:

- Completing a request on the RMA Request page in the *Support* section at [www.patton.com](http://www.patton.com)
- By calling +1 (301) 975-1007 and speaking to a Technical Support Engineer
- By sending an e-mail to [returns@patton.com](mailto:returns@patton.com)

All returned units must have the RMA number clearly visible on the outside of the shipping container. Please use the original packing material that the device came in or pack the unit securely to avoid damage during shipping.

### *Shipping instructions*

The RMA number should be clearly visible on the address label. Our shipping address is as follows:

**Patton Electronics Company**

RMA#: xxxx

7622 Rickenbacker Dr.

Gaithersburg, MD 20879-4773 USA

Patton will ship the equipment back to you in the same manner you ship it to us. Patton will pay the return shipping costs.

## Appendix A **Compliance Information**

### **Chapter contents**

Compliance .....	38
EMC .....	38
Safety .....	38
PSTN Regulatory .....	38
FCC Part 68 (ACTA) Statement .....	39
Industry Canada Notice .....	39
CE Declaration of Conformity .....	40
Authorized European Representative .....	40

## Compliance

---

### **EMC**

- EN55022, Class A
- EN55024

### **Safety**

- IEC/EN60950-1, 2nd edition

### **PSTN Regulatory**

- ACTA (Part 68)
- IC CS-03
- AS/ACIF S016:2001
- AS/ACIF S038:2001
- ETSI TBR 12, TBR 12/A1 & TBR 13
- TBR 4
- TNA 117: 1992
- TNA 134: 1997
- PTC 220

## FCC Part 68 (ACTA) Statement

---

This equipment complies with Part 68 of FCC rules and the requirements adopted by ACTA. On the bottom side of this equipment is a label that contains—among other information—a product identifier in the format US: AAAEQ##TXXXX. If requested, this number must be provided to the telephone company.

The method used to connect this equipment to the premises wiring and telephone network must comply with the applicable FCC Part 68 rules and requirements adopted by the ACTA.

If this equipment causes harm to the telephone network, the telephone company will notify you in advance that temporary discontinuance of service may be required. But if advance notice isn't practical, the telephone company will notify the customer as soon as possible. Also, you will be advised of your right to file a complaint with the FCC if you believe it is necessary.

The telephone company may make changes in its facilities, equipment, operations or procedures that could affect the operation of the equipment. If this happens the telephone company will provide advance notice in order for you to make necessary modifications to maintain uninterrupted service.

If trouble is experienced with this equipment, for repair or warranty information, please contact our company. If the equipment is causing harm to the telephone network, the telephone company may request that you disconnect the equipment until the problem is resolved.

Connection to party line service is subject to state tariffs. Contact the state public utility commission, public service commission or corporation commission for information.

## Industry Canada Notice

---

This equipment meets the applicable Industry Canada Terminal Equipment Technical Specifications. This is confirmed by the registration number. The abbreviation, IC, before the registration number signifies that registration was performed based on a Declaration of Conformity indicating that Industry Canada technical specifications were met. It does not imply that Industry Canada approved the equipment.

This Declaration of Conformity means that the equipment meets certain telecommunications network protective, operational and safety requirements. The Department does not guarantee the equipment will operate to the user's satisfaction. Before installing this equipment, users should ensure that it is permissible to be connected to the facilities of the local telecommunications company. The equipment must also be installed using an acceptable method of connection. In some cases, the company's inside wiring associated with a single line individual service may be extended by means of a certified connector assembly (telephone extension cord). The customer should be aware that compliance with the above condition may not prevent degradation of service in some situations. Repairs to some certified equipment should be made by an authorized maintenance facility designated by the supplier. Any repairs or alterations made by the user to this equipment, or equipment malfunctions, may give the telecommunications company cause to request the user to disconnect the equipment. Users should ensure for their own protection that the ground connections of the power utility, telephone lines and internal metallic water pipe system, are connected together. This protection may be particularly important in rural areas.

## CE Declaration of Conformity

---

Patton Electronics, Inc declares that this device is in compliance with the essential requirements and other relevant provisions of Directive 2004/108/EC relating to electromagnetic compatibility, Directive 2006/95/EC relating to electrical equipment designed for use within certain voltage limits and Directive 2011/65/EC relating to RoHS compliance. The Declaration of Conformity may be obtained from Patton Electronics, Inc at [www.patton.com/certifications](http://www.patton.com/certifications).

The safety advice in the documentation accompanying this device shall be obeyed. The conformity to the above directive is indicated by CE mark on the device.

## Authorized European Representative

---

D R M Green

European Compliance Services Limited.

Greyfriars Court

Paradise Square

Oxford, OX1 1BE, UK



## Appendix B **Specifications**

---

### **Chapter contents**

Data Connectivity .....	42
Voice Processing (signaling dependent) .....	42
Fax and Modem Support.....	42
Voice Signaling.....	42
IP Services .....	43
Management .....	43
System .....	43
Physical .....	43
WAN Daughter Card (if applicable).....	44
Identification of the SmartNode Devices via SNMP.....	45

## Data Connectivity

---

Two 10/100/1000Base-Tx Gigabit Ethernet ports

All ports full duplex, autosensing, auto-MDX

## Voice Processing (signaling dependent)

---

Up to 128 full-duplex channels with Voice CODECS:

- G.711 A-Law/ $\mu$ -Law (64 kbps)
- G.726 (ADPCM 16, 24, 32, 40 kbps)
- G.723.1 (5.3 or 6.3 kbps)
- G.729ab (8 kbps)
- Transparent ISDN data

G.168 echo cancellation (128 ms)

Up to 120 simultaneous voice or T.38 fax calls

DTMF detection and generation

Carrier tone detection and generation

Silence suppression and comfort noise

Adaptive and configurable dejitter buffer

Configurable tones (dial, ringing, busy)

Configurable transmit packet length

RTP/RTCP (RFC 1889)

## Fax and Modem Support

---

Automatic fax and modem detection

Codec fallback for modem-bypass

T.38 Fax-Relay (Gr. 3 Fax, 9.6 k, 14.4 k)

G.711 Fax-Bypass

## Voice Signaling

---

SIPv2

H.323v4

MGCP/IUA

SIP call transfer, redirect

Overlap or en-bloc dialing

DTMF in-band, out-of-band

Configurable progress tones

## IP Services

---

IPv4 router; RIPv1, v2 (RFC 1058 and 2453)

Programmable static routes

ICMP redirect (RFC 792); Packet fragmentation

DiffServe/ToS set or queue per header bits

Packet Policing discards excess traffic

802.1p VLAN tagging

IPSEC AH & ESP Modes

Manual Key; IKE

AES/DES/3DES Encryption

## Management

---

Web-based GUI

Industry standard CLI with local console (RJ-45, RJ-231, 9600 bps, 8, N, 1) and remote Telnet access, fully documented

HTTP web management and firmware loading

TFTP configuration & firmware loading

SNMP v1 agent (MIB II and private MIB)

Built-in diagnostic tools (trace, debug)

Secure Auto-provisioning

## System

---

CPU Motorola MPC8360 series operating at 400 MHz

Memory:

- 256 Mbytes RAM (DDR, 266MHz)
- 32 Mbytes Flash

## Physical

---

**Dimensions:** 11.9W x 1.71H x 7.16D inch (302W x 44H x 182mm)

**Weight:** <21 oz. (<600g)

**Power Consumption:** < 16W

**Operating temperature:** 32–104°F (0–40°C)

**Operating humidity:** up to 90%, non condensing

## WAN Daughter Card (if applicable)

Table 10. G.SHDSL Daughter Card Specifications

Factor	Specs
<b>DSL</b>	<ul style="list-style-type: none"> <li>• ITU-T G.991.2 (and Amendment 2)</li> <li>• ITU-T G.991.2, Annex A, B, F, G</li> <li>• Upgradable to ITU-T G.SHDSL.BIS—Annex F and G</li> <li>• G.991.2 2/4 (1/2 pair) operation</li> <li>• G.994.1 (G.hs) (per G.991.2)</li> <li>• ITU-T G.991.2 Section E.9 (TPS-TC for ATM transport)</li> <li>• ITU-T EFM</li> </ul>
<b>DSL Connection</b>	RJ-11/12 (2-wire)
<b>Management</b>	<ul style="list-style-type: none"> <li>• I.610 OAM F4/F5</li> <li>• Management interfaces: GUI and Telnet</li> <li>• Software upgrade: GUI and TFTP</li> </ul>
<b>ATM Support</b>	<ul style="list-style-type: none"> <li>• Classical IPoA (RFC 1577/2225)</li> <li>• PPPoE Client (over ATM) (RFC 2516)</li> <li>• IPoA (RFC 2684/1483)</li> <li>• ATM AAL5 encapsulation</li> <li>• Max. 8 PVCs</li> <li>• User selectable VC MUX and LLC MUX (default)</li> <li>• Configurable auto-connection</li> <li>• ATM QoS: UBR (default), CBR, and VBR-rt, VBR-nrt, UBR: per VC queuing</li> <li>• Auto-configuration: TR-037 &amp; ILMI 4.0</li> </ul>
<b>Interworking/Interoperability</b>	<ul style="list-style-type: none"> <li>• G.SHDSL Interoperability: <ul style="list-style-type: none"> <li>- Alcatel</li> <li>- NEC</li> <li>- Lucent Anymedia</li> <li>- Lucent Stinger</li> </ul> </li> <li>• BRAS Interoperability: <ul style="list-style-type: none"> <li>- Cisco</li> <li>- Redback</li> </ul> </li> </ul>
<b>Fiber</b>	<ul style="list-style-type: none"> <li>• 100Mbps and 1000Mbps Fiber SFP</li> </ul> (For a list of test SFP modules, please refer to <a href="http://www.patton.com/products/sfpmodules.asp">http://www.patton.com/products/sfpmodules.asp</a> )

## Identification of the SmartNode Devices via SNMP

All SmartNode devices have assigned sysObjectID (.iso.org.dod.internet.mgmt.mib-2.system.sysObjectID) numbers (see Table 11).

Table 11. SmartNode Models and their Unique sysObjectID

SmartNode Model	SysObjectID
SN5480/32P	.iso.org.dod.internet.private.enterprises.patton.products.sn4970.1 1.3.6.1.4.1.1768.100.4.24.1
SN5480/64P	.iso.org.dod.internet.private.enterprises.patton.products.sn4970.2 1.3.6.1.4.1.1768.100.4.24.2
SN5490/32P2GS	.iso.org.dod.internet.private.enterprises.patton.products.sn4970.3 1.3.6.1.4.1.1768.100.4.24.3
SN5490/64P2GS	.iso.org.dod.internet.private.enterprises.patton.products.sn4970.4 1.3.6.1.4.1.1768.100.4.24.4

According to Table 11, an SNMP get request to *.iso.org.dod.internet.mgmt.mib-2.system.sysObjectID* of a SmartNode 5480/32P/EUI device reads out a numeric OID of *1.3.6.1.4.1.1768.100.4.24.1*. The mapping of the sysObjectID to each of the SmartNode model is realized with the SmartNode product identification MIB.



The SNMP agent running in SmartWare is SNMP version 1 (SNMPv1) compliant. SNMP version 2 (SNMPv2) and SNMP version 3 (SNMPv3) are not currently supported.

## Appendix C **Cabling**

---

### **Chapter contents**

Introduction .....	47
Console .....	47
Ethernet .....	48

## Introduction

This section provides information on the cables used to connect the SmartNode and the interface cards to the existing network infrastructure and to third party products.

## Console

The SmartNode can be connected to a serial terminal over its serial console port, as depicted in [Figure 12](#).



CAUTION

The interconnecting cables shall be acceptable for external use and shall be rated for the proper application with respect to voltage, current, anticipated temperature, flammability, and mechanical serviceability.

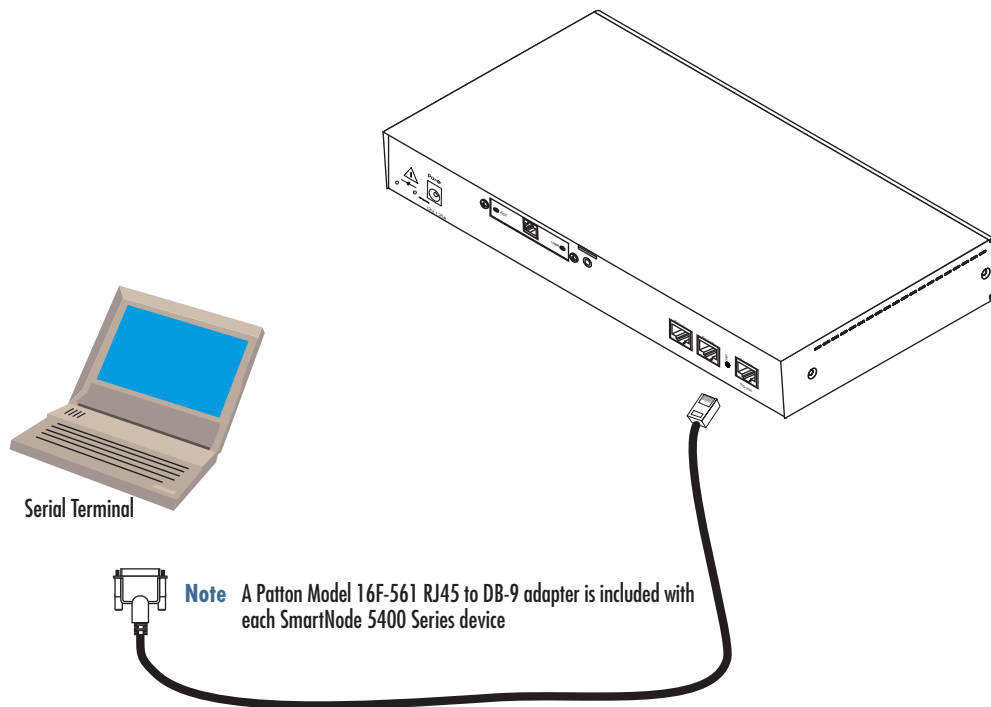

Figure 12. Connecting a serial terminal

**Note** See section “[Console Port](#)” on page 50 for console port pin-outs.

## Ethernet

Ethernet devices (10Base-T/100Base-T/1000Base-T) are connected to the SmartNode over a cable with RJ-45 plugs. All Ethernet ports on the SN5480/5490 are Auto-MDX use any straight or crossover cable to connect to hubs, switches, PCs or other devices.



The interconnecting cables shall be acceptable for external use and shall be rated for the proper application with respect to voltage, current, anticipated temperature, flammability, and mechanical serviceability.

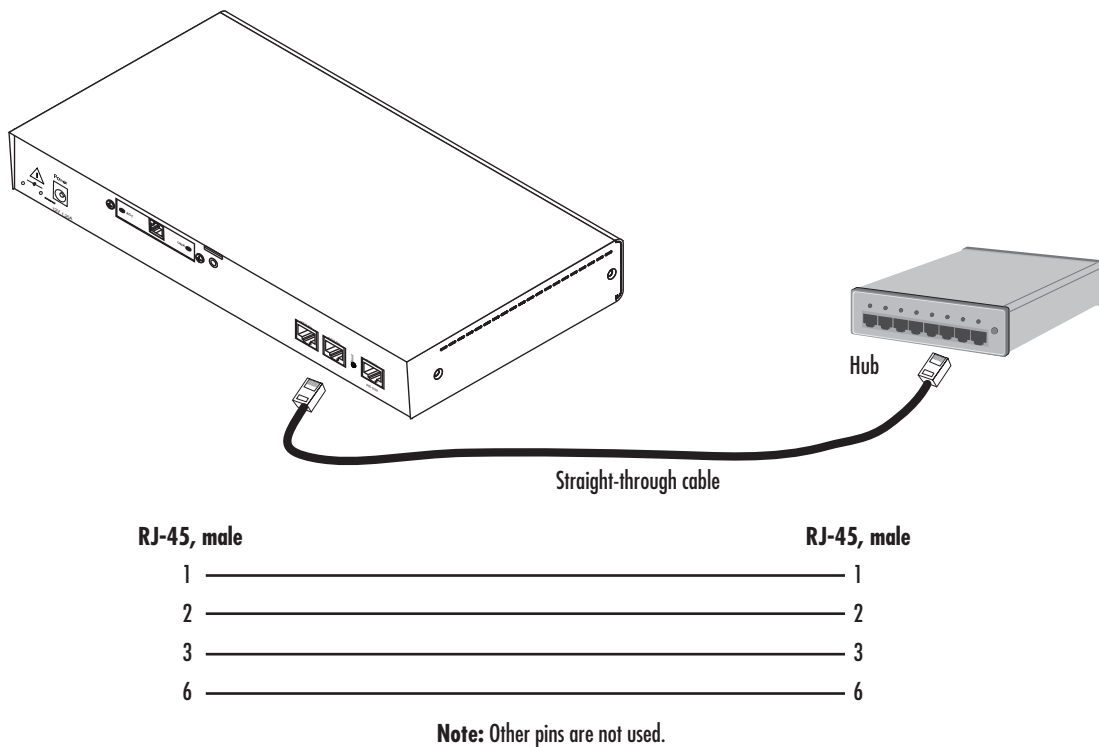

Figure 13. Typical Ethernet straight-through cable diagram for 10/100Base-T

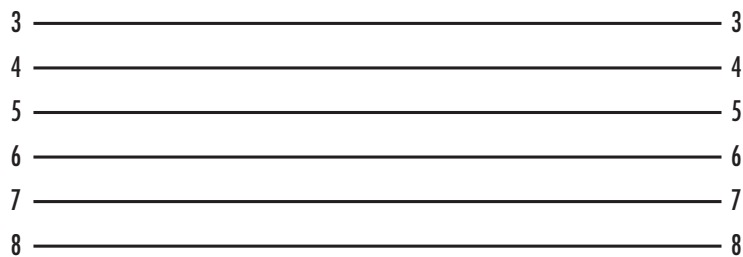

Figure 14. Typical Ethernet straight-through cable diagram for 1000Base-T



## Appendix D **Port Pin-outs**

---

### **Chapter contents**

Introduction .....	50
Console Port .....	50
Ethernet .....	50
G.SHDSL Port .....	51
EFM Port .....	52
Fiber Port .....	52

## Introduction

This section provides pin-out information for the ports of the SmartNode.

## Console Port

**Configuration settings:** 9600 bps, 8 bits, no parity, 1 stop bit, no flow control

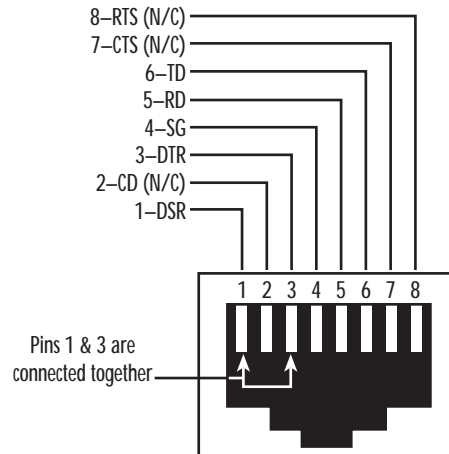

Figure 15. EIA-561 (RJ-45 8-pin) port

**Note** *N/C* means no internal electrical connection.

## Ethernet

Table 12. RJ45 socket 10/100Base-T

Pin	Signal
1	TX+
2	TX-
3	RX+
6	RX-

**Note** Pins not listed are not used.

Table 13. RJ45 socket 1000Base-T

Pin	Signal
1	TRD0+
2	TRD0-
3	TRD1+
6	TRD1-
4	TRD2+
5	TRD2-
7	TRD3+
8	TRD3-

## G.SHDSL Port

---

Table 14. RJ-45 connector

Pin	Signal
1	No connection
2	No connection
3	Tip 2
4	Tip 1
5	Ring 1
6	Ring 2
7	No connection
8	No connection

## EFM Port

---

Table 15. RJ-45 connector

Pin	Signal	Pair
1	Tip	1
2	Ring	1
3	Tip	2
4	Ring	0
5	Tip	0
6	Ring	2
7	Tip	3
8	Ring	3

## Fiber Port

---

For tested and approved modules, please refer to the list of SFP's Patton has tested at <http://www.patton.com/products/sfpmodules.asp>.

# Appendix E **SmartNode 5480 and 5490 Series Factory Configuration**

---

## **Chapter contents**

Introduction .....	54
--------------------	----

## Introduction

---

The factory configuration settings for SmartNode 5480 and 5490 Series are as follows:

```
#-----#
#                                             #
# Factory configuration file                 #
#                                             #
#-----#

dns-relay

dns-relay

timer PROVISIONING now + 1 minute "provisioning execute PF_PROVISIONING_CONFIG"

sntp-client

sntp-client server primary pool.ntp.org

profile provisioning PF_PROVISIONING_CONFIG

    destination configuration

    activation reload immediate

    location 1 http://redirect.patton.com/
    $(system.mac);mac=$(system.mac);serial=$(system.serial);hwMajor=$(system.hw.major);hwMi
    nor=$(system.hw.minor);swMajor=$(system.sw.major);swMinor=$(system.sw.minor);swDate=$(s
    ystem.sw.date);productName=$(system.product.name);cliMajor=$(cli.major);cliMinor=$(cli.
    minor);osName=$(cli.major>=4|Trinity|SmartWare);subDirTrinity=$(cli.major>=4|Trin-
    ity);subDirSmartWare=$(cli.major<4|SmartWare);dhcp66=$(dhcp.66);dhcp67=$(dhcp.67)

    location 2 $(dhcp.66)

    location 3 $(dhcp.66)/$(system.mac).cfg

    location 4 http://$(dhcp.66)/$(dhcp.67)

    location 5 http://$(dhcp.66)/$(system.mac).cfg

    location 6 tftp://$(dhcp.66)/$(dhcp.67)

    location 7 tftp://$(dhcp.66)/$(system.mac).cfg

system

    ic voice 0

profile napt NAPT_WAN

profile dhcp-server DHCP_SERVER_LAN

    network 192.168.1.0 255.255.255.0
```

```
include 1 192.168.1.10 192.168.1.99

lease 2 hours

default-router 1 192.168.1.1

domain-name-server 1 192.168.1.1

context ip router

interface WAN

    ipaddress dhcp

    use profile napt NAPT_WAN

    tcp adjust-mss rx mtu

    tcp adjust-mss tx mtu

interface LAN

    ipaddress 192.168.1.1 255.255.255.0

    tcp adjust-mss rx mtu

    tcp adjust-mss tx mtu

context ip router

    dhcp-server use DHCP_S_LAN

port ethernet 0 0

    medium auto

    encapsulation ip

    bind interface WAN router

    no shutdown

port ethernet 0 1

    medium auto

    encapsulation ip

    bind interface LAN router

    no shutdown
```

# Appendix F **End User License Agreement**

## **Chapter contents**

- End User License Agreement .....57
  - 1. Definitions .....57
  - 2. Title .....57
  - 3. Term .....57
  - 4. Grant of License .....57
  - 5. Warranty .....57
  - 6. Termination .....58
  - 7. Other licenses .....58
  - 8. SmartWare licenses .....58



## End User License Agreement

---

By opening this package, operating the Designated Equipment or downloading the Program(s) electronically, the End User agrees to the following conditions:

### 1. Definitions

- A) *Effective Date* shall mean the earliest date of purchase or download of a product containing the Patton Electronics Company Program(s) or the Program(s) themselves.
- B) *Program(s)* shall mean all software, software documentation, source code, object code, or executable code.
- C) *End User* shall mean the person or organization which has valid title to the Designated Equipment.
- D) *Designated Equipment* shall mean the hardware on which the Program(s) have been designed and provided to operate by Patton Electronics Company.

### 2. Title

Title to the Program(s), all copies of the Program(s), all patent rights, copyrights, trade secrets and proprietary information in the Program(s), worldwide, remains with Patton Electronics Company or its licensors.

### 3. Term

The term of this Agreement is from the Effective Date until title of the Designated Equipment is transferred by End User or unless the license is terminated earlier as defined in section “6. Termination” on page 58.

### 4. Grant of License

- A) During the term of this Agreement, Patton Electronics Company grants a personal, non-transferable, non-assignable and non-exclusive license to the End User to use the Program(s) only with the Designated Equipment at a site owned or leased by the End User.
- B) The End User may copy licensed Program(s) as necessary for backup purposes only for use with the Designated Equipment that was first purchased or used or its temporary or permanent replacement.
- C) The End User is prohibited from disassembling; decompiling, reverse-engineering or otherwise attempting to discover or disclose the Program(s), source code, methods or concepts embodied in the Program(s) or having the same done by another party.
- D) Should End User transfer title of the Designated Equipment to a third party after entering into this license agreement, End User is obligated to inform the third party in writing that a separate End User License Agreement from Patton Electronics Company is required to operate the Designated Equipment.

### 5. Warranty

The Program(s) are provided *as is* without warranty of any kind. Patton Electronics Company and its licensors disclaim all warranties, either express or implied, including but not limited to the implied warranties of merchantability, fitness for a particular purpose or non-infringement. In no event shall Patton Electronics Company or its licensors be liable for any damages whatsoever (including, without limitation, damages for loss of business profits, business interruption, loss of business information, or other pecuniary loss) arising out of the use of or inability to use the Program(s), even if Patton Electronics Company has been advised of the possibility of such damages. Because some states do not allow the exclusion or limitation of liability for consequential or incidental damages, the above limitation may not apply to you.

If the Program(s) are acquired by or on behalf of a unit or agency of the United States Government, the Government agrees that such Program(s) are *commercial computer software* or *computer software documentation* and that, absent a written agreement to the contrary, the Government's rights with respect to such Program(s) are limited by the terms of this Agreement, pursuant to Federal Acquisition Regulations 12.212(a) and/or DEARS 227.7202-1(a) and/or sub-paragraphs (a) through (d) of the "Commercial Computer Software - Restricted Rights" clause at 48 C.F.R. 52.227-19 of the Federal Acquisition Regulations as applicable.

## 6. Termination

- A) The End User may terminate this agreement by returning the Designated Equipment and destroying all copies of the licensed Program(s).
- B) Patton Electronics Company may terminate this Agreement should End User violate any of the provisions of section "4. Grant of License" on page 57.
- C) Upon termination for A or B above or the end of the Term, End User is required to destroy all copies of the licensed Program(s)

## 7. Other licenses

The Program may be subject to licenses extended by third parties. Accordingly, Patton Electronics Company licenses the Programs subject to the terms and conditions dictated by third parties. Third party software identified to the Programs includes:

- The LGPL (Lesser General Public License) open source license distributed to you pursuant to the LGPL license terms (<http://www.gnu.org/licenses/lgpl.html>).

## 8. SmartWare licenses

- A routing license is included at no charge.
- MGCP and VPN capabilities will require the purchase of an additional license.

RedBoot (Red Hat Embedded Debug and Bootstrap) embedded system debug/bootstrap environment from Red Hat distributed to you pursuant to the eCos license terms (<http://ecos.sourceware.org/license-overview.html>) and GNU General Public License (GPL) terms (<http://www.gnu.org/copyleft/gpl.html>). Source code is available upon request.