

OPERATIONS MANUAL

MODEL 1001MC NetLink™ SNMP Management Card



Patton
Electronics Co.



An ISO-9001
Certified Company

Part# 07M1001MC-C
Doc# 022021UC
Revised 05/25/01

SALES OFFICE
(301) 975-1000
TECHNICAL SUPPORT
(301) 975-1007
<http://www.patton.com>

Patton Electronics Company, Inc.

7622 Rickenbacker Drive
Gaithersburg, MD. 20879

tel: 301-975-1000

fax: 301-869-9293

support: 301-975-1007

web: <http://www.patton.com>

email: support@patton.com

Copyright © 2000, 2001 Patton Electronics Company. All rights reserved.

The information in this document is subject to change without notice. Patton Electronics assumes no liability for errors that may appear in this document.

The software described in this document is furnished under a license and may be used or copied only in accordance with the terms of such license.

Table of Contents

About This Guide	v
Audience	vi
Preview of this Operations Manual.....	vi
Documentation Conventions.....	vi
Compliance Information	vii
Additional References	vii
RFCs.....	vii
Contacting Technical Support.....	viii
1. Introduction	1-1
Warranty Information	1-2
Features	1-3
General Description	1-3
1001MC Management Solutions	1-4
System Requirements	1-6
Checking the Contents	1-6
Making Connections	1-7
Connecting the 10Base-T Ethernet Port	1-8
Connecting a 10Base-T Hub to the 1001MC	1-8
Connecting a 10Base-T Workstation to the 1001MC	1-8
Connecting the RS-232 Configuration/Daisy Chain Port	1-9
Connecting the Power Supply	1-9
Installing the 1001MC into the Chassis.....	1-10
Reading the LED Status Indicators	1-10
2. Getting Started	
Booting the 1001MC	2-2

3. Using the Internal HTTP/HTML Management Pages	3-1
Introduction to the Internal HTTP/HTML Management Pages.....	3-2
Logging into the HTTP/HTML Pages	3-2
HTTP/HTML and SNMP Object Format	3-3
Saving HTTP/HTML Object Changes	3-3
Help Screens	3-3
HOME	3-7
Box Information	3-8
Operating Status Variables	3-9
Immediate Actions	3-10
System Level Information	3-11
Modem Information	3-13
Slot Configuration.....	3-16
System Information	3-18
System Log.....	3-20
System Log Modify	3-21
System Log: Volatile Memory	3-23
System Log: Non-Volatile Memory.....	3-24
Software Upgrades for NetLink Modems.....	3-25
About 1001MC.....	3-26
Appendix A SNMP -- NetLink Model 1095	A-1

1001MC Operations Manual
Table of Contents

About This Guide

Table of Contents

Audience.....	vi
Preview of this Operations Manual	vi
Documentation Conventions	vi
Compliance Information	vii
Additional References	vii
ITU-T Recommendations	vii
RFCs	vii
Contacting Technical Support	viii

Audience

This Operations Manual is intended to be used by qualified systems administrators and network engineers to successfully configure and manage the Patton Electronics Model 1001MC and NetLink modems. Knowledge of basic networking concepts is assumed.

Preview of this Operations Manual

Chapter 1, Introduction provides a general description of the 1001MC, including product features, terminology descriptions, product applications, connections, LED descriptions and product specifications.

Chapter 2, Getting Started provides a description of how the 1001MC works, how to set and save initial operating parameters, as well as a general introduction to system management.

Chapter 3, Using The Internal HTML Management Pages provides a description of the 1001MC's internal HTTP/HTML management pages.

Documentation Conventions

Table A-1. Documentation Conventions	
Convention	Meaning
Bold Helvetica Text	Describes configuration commands or parameters that you may enter or change to configure the 1001MC.
NOTE:	Denotes important additional information.
WARNING!	Means that a failure to take appropriate safety measures could result in physical injury.
<i>Application Tips!</i>	Denote helpful hints that could aid in 1001MC operation or troubleshooting.
(snmpVariable)	Denote SNMP or Patton Enterprise MIB Variables

Compliance Information

The CE symbol on your Patton Electronics equipment indicates that it is in compliance with the Electromagnetic Compatibility (EMC) directive and the Low Voltage Directive (LVD) of the Union European (EU). A Certificate of Compliance is available by contacting Technical Support.

1.2 FCC INFORMATION

This equipment has been tested and found to comply with the limits for a Class A digital device, pursuant to Part 15 of the FCC Rules. These limits are designed to provide reasonable protection against harmful interference when the equipment is operated in a commercial environment. This equipment generates, uses, and can radiate radio frequency energy and, if not installed and used in accordance with the instruction manual, may cause harmful interference to radio communications. Operation of this equipment in a residential area is likely to cause harmful interference in which case the user will be required to correct the interference at his own expense. If this equipment does cause harmful interference to radio or television reception, which can be determined by turning the equipment off and on, the user is encouraged to try to correct the interference by one or more of the following measures:

- Reorient or relocate the receiving antenna
- Increase the separation between the equipment and receiver
- Connect the equipment into an outlet on a circuit different from that to which the receiver is connected

Additional References

Patton Electronics website (www.patton.com) provides 1001MC and NetLink modem application notes, which includes FAQ, startup notes, and test setups.

RFCs

You may use a World Wide Web browser to find online copies of the following Requests for Comments (RFC).

RFC 1643, *Definitions of Managed Objects for the Ethernet-like Interface Types*
RFC 1155, *Structure and Identification of Management Information for TCP/IP-based Internets*
RFC 1213, *Management Information Base for Network Management of TCP/IP-based internets: MIB-II*
RFC 1389, *RIP Version 2 MIB Extension*
RFC 1643, *Definitions of Managed Objects for the Ethernet-like Interface Types*

Contacting Technical Support

Patton Electronics' technical staff is also available to answer any questions that might arise concerning the installation or use of your Model 1001MC. Technical Service hours: **8AM to 5PM EST, Monday through Friday.**

All warranty and non-warranty repairs must be returned freight prepaid and insured to Patton Electronics. All returns must have a Return Materials Authorization number on the outside of the shipping container. This number may be obtained from Patton Electronics Technical Service at **(301) 975-1007; <http://www.patton.com>; or, support@patton.com.**

NOTE: Packages received without an RMA number will not be accepted.

Introduction

Table of Contents

Warranty Information.....	1-2
Features	1-3
General Description	1-3
1001MC Management Solutions	1-4
System Requirements.....	1-6
Checking the Contents	1-6
Making Connections	1-7
Connecting the 10Base-T Ethernet Port.....	1-8
Connecting a 10Base-T Hub to the 1001MC.....	1-8
Connecting a 10Base-T Workstation to the 1001MC	1-8
Connecting the RS-232 Configuration/Daisy Chain Port	1-9
Connecting the Power Supply	1-9
Installing the 1001MC into the Chassis.....	1-10
Reading the LED Status Indicators	1-10

Warranty Information

Patton Electronics warrants all Model 1001MC Series components to be free from defects, and will at our option repair or replace the product should it fail within one year from the first date of shipment. This warranty is limited to defects in workmanship or materials, and does not cover customer damage, abuse, or unauthorized modification. This product contains no serviceable parts; therefore, do not attempt to modify the unit in any way. If this product fails or does not perform as warranted, your sole recourse shall be repair or replacement as described above. Under no condition shall **Patton Electronics** be liable for any damages incurred by the use of this product. These damages include, but are not limited to, the following: lost profits, lost savings and incidental or consequential damages arising from the use of or inability to use this product. **Patton Electronics** specifically disclaims all other warranties, expressed or implied, and the installation or use of this product shall be deemed an acceptance of these terms by the user.

Features

- Allows one SNMP workstation to manage multiple Patton NetLink™ racks
- Fully manageable using HTTP/HTML management screens from any workstation using any standard web browser
- Supports generic network management software and MIB walking tools
- Connects to an SNMP workstation using Ethernet LAN connection
- Functions as an SNMP proxy agent for Patton NetLink rack cards and their remote standalone units
- Hot Swappable installation—uses one slot on a Patton NetLink™ Rack System
- FLASH upgradeable through ftp connection
- User selectable traps on a per-card basis

General Description

The **Patton Model 1001MC Network™ Management Card** allows an SNMP workstation to configure and monitor multiple Patton NetLink™ racks full of cards, plus their connected standalone units! Designed to work with Patton's NetLink rack cards (Model 1095RC, 1094ARC, etc.), the Patton Model 1001MC supports generic SNMP management software and MIB walking tools. Or use a standard web browser (Internet Explorer™ or Netscape™) and the embedded HTTP/HTML management screens.

The Patton Model 1001MC connects to an SNMP workstation using an Ethernet (10BaseT) link. The Ethernet (modular RJ-45) port on the Model 1001MC may also be used for FLASH software upgrades by making a ftp connection to the unit.

1001MC Management Solution

The Model 1001MC uses a 10Base-T Ethernet port to connect to a local LAN or to anywhere in the world via the internet. Management can be performed using any standard SNMP station or using a standard web browser with the internal HTTP/HTML management screens. As shown in Figure 1-1 below, the Model 1001MC can manage multiple racks of Patton NetLink modems using a simple daisy chain connection and a 1001CC in each additionally managed rack.

Figure 1-1. Network Management through a network using a 10Base-T Connection to Model 1001MC

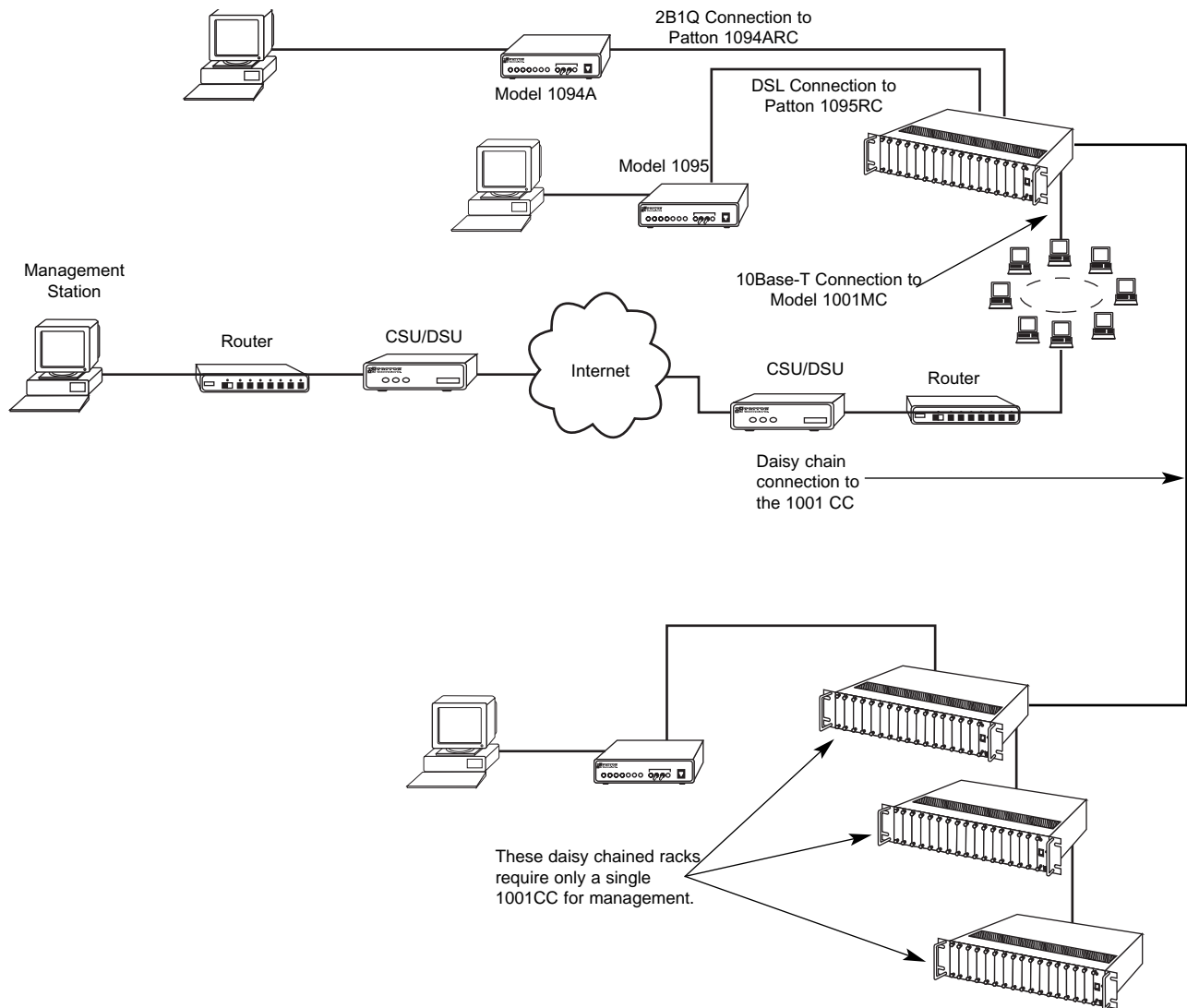

1. Introduction

System Requirements

Before you can fully install and configure your Model 1001MC please make sure you have these items available.

- A VT100 terminal or a VT100 terminal emulator for connection to the EIA-232 configuration port
- A Null modem or a Null modem cable to connect your VT100 terminal to the Model 1001MC
- An Ethernet connection to your local LAN
- A locally connected workstation (e.g. PC) that you can use to PING and HTTP into the 1001MC
- An IP address for the Model 1001MC
- The network address space and netmask
- The IP address for the default gateway of your LAN

Checking the Contents

The following items are included at time of shipment. Please take a moment to account for the following items:

Model 1001MC Contents

<u>Quantity</u>	<u>Description</u>
1	1001MC Front and Rear Card
1	Operations Manual

Making Connections

The 1001MC fits into the Model 1001R14/16 NetLink™ Rack Chassis. The 1001MC is designed to SNMP manage local Patton NetLink rack cards, such as Models 1094ARC and 1095RC, and their remote counterparts. The Model 1001R16 Rack Chassis has fifteen short range modem card slots, plus its own power supply. Redundant power supplies are also available in the NetLink system. The 1001MC can also manage up to seven more daisy chained racks, and requires only a 1001CC in each additional rack. Measuring only 3.5 high, the Model 1001R14/16 is designed to occupy only 2U in a 19 rack. Sturdy front handles allow the Model 1001R14/16 to be extracted and transported conveniently.

Figure 1-2. Model 1001R14/16 Rack Chassis with Power Supply

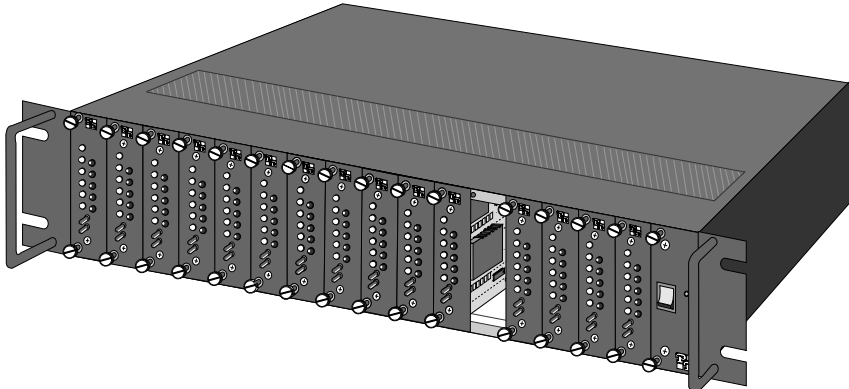
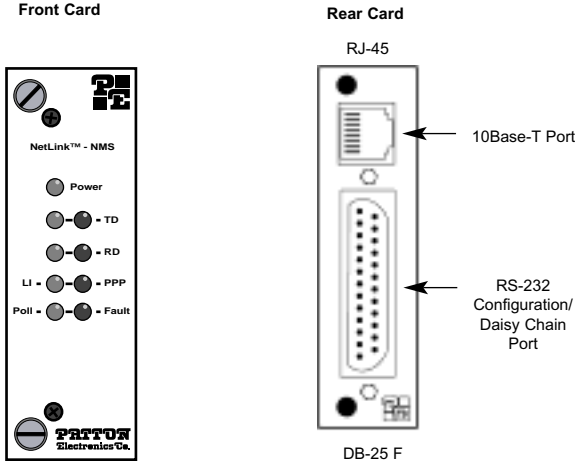

Figure 1-3, below, shows the Model 1001MC front and rear panels. The following sections describe the rear card connections and front panel LED indicators.

Figure 1-3. Model 1001MC Front and Rear Panels



1. Introduction

Connecting the 10BaseT Ethernet Port

The RJ-45 Ethernet port on the rear panel of the Model 1001MC is designed to connect directly to a 10BaseT network. The diagram below shows the 10BaseT RJ-45 port pin description. Please refer to the instructions below when constructing cables to connect 10BaseT ports to the Patton Model 1001MC. You may make connections up to 330 feet using Type 4 or 5 cable.

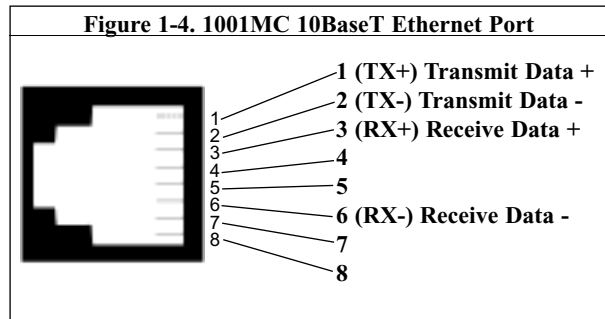

Connecting a 10BaseT Hub to the 1001MC

The Ethernet 10BaseT port on the rear of the 1001MC is designed to connect directly to a 10BaseT hub or repeater using RJ-45 unshielded twisted pair cable that is wired *straight through*. Follow the diagram below to construct a *straight through* cable to connect a 10BaseT Hub to the Model 1001MC s 10BaseT port.

10BaseT Hub RJ-45 Pin No.	-----	1001MC 10BaseT Port RJ-45 Pin No.
3 (TX+)	-----	3 (RX+)
6 (TX-)	-----	6 (RX-)
1 (RX+)	-----	1 (TX+)
2 (RX-)	-----	2 (TX-)

Connecting a 10BaseT Workstation to the 1001MC

The 10BaseT port on the 1001MC may also be connected directly to a 10BaseT workstation by means of a cross-connect cable. Follow the diagram below to build a cross-connect cable to connect the 10BaseT port on a workstations NIC to the 1001MC 10BaseT port.

10BaseT WorkStation RJ-45 Pin No.	-----	1001MC 10BaseT Port RJ-45 Pin No.
1 (TX+)	-----	3 (RX+)
2 (TX-)	-----	6 (RX-)
3 (RX+)	-----	1 (TX+)
6 (RX-)	-----	2 (TX-)

Connecting the RS-232 Configuration/Daisy Chain Port

Your Model 1001MC is equipped with a DB-25 connector on the rear panel of the unit. This connector is a DTE configured RS-232 port that has two functions. When you first install your system, use this configuration port to setup your IP address, subnet mask, and default configuration. After the system is set up, the configuration port can be used to connect to a 1001CC in a separate rack to allow daisy chain configuration of multiple racks.

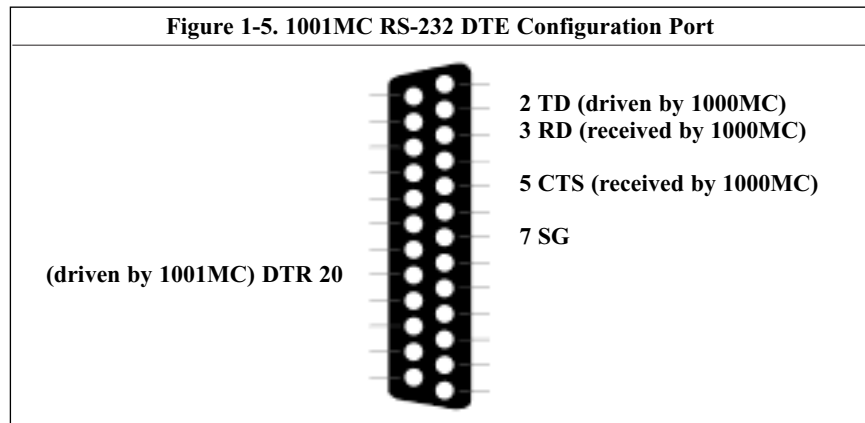

Note: The configuration port on your 1001MC is a DTE, which requires a null modem or equivalent cable when connecting to a terminal.

Using personal computer communications software (Procomm, Windows Terminal, BitCom, PC Anywhere, etc.), set the configuration of your communications software to the following parameters:

Data Rate:	19,200 bps
Async. Character Format:	8 Data Bits, 1 Stop Bit, No Parity
Terminal Emulation:	VT-100 (or similar) terminal emulation

Connecting the Power Supply

The power supply included in the Model 1001R14/16 rack uses the same mid-plane architecture as the modem cards. The front card of the power supply slides in from the front, and the rear card slides in from the rear. They plug into one another in the middle of the rack. The front card is then secured by captive screws and the rear card by conventional metal screws.

WARNING! There are no user-serviceable parts in the power supply section. Voltage setting changes and fuse replacement should only be performed by qualified service personnel. Contact Patton Electronics Technical support at (301)975-1007 for more information.

1. Introduction**Installing the Model 1001MC into the Rack Chassis**

Note: Install the 1001MC in the chassis, next to the redundant power supplies. If you are using a single power supply, install the 1001MC in slot 14 (two slots away from the single supply). The bus bar contained in the NetLink (1001) rack has an extra connector at this slot which communicates information about the power supplies to the 1001MC. If the card is not installed in the correct slot, the 1001MC will default to the failure mode for the power supplies.

The Model 1001MC Series is comprised of a front card and a rear card. The two cards meet inside the rack chassis and plug into each other by way of mating 50 pin card edge connectors. Use the following steps as a guideline for installing each Model 1001MC Series into the rack chassis:

1. Slide the rear card into the back of the chassis along the metal rails provided.
2. Secure the rear card using the metal screws provided.
3. Slide the front card into the front of the chassis. It should meet the rear card when it is almost all the way into the chassis.
4. Push the front card *gently* into the card-edge receptacle of the rear card. It should click into place.
5. Secure the front card using the thumb screws.

Reading the LED Indicators

The 1001MC front panel has numerous status LEDs to visually inform of the current operations status and health of the 1001MC. Figure 1-3 shows the LEDs on the 1001MC front panel.

Ethernet LED Indicators

The Ethernet LEDs convey Transmit and Receive Data activity as well as the status of the link.

TABLE 1-1. Ethernet LED Indicators		
LED	Function/Color	Description
LI	Twisted Pair Link Indication Green	On = Connected to active LAN Off = Not connected to active LAN
TD	Transmit Data from 1001MC to LAN Yellow/Green	Yellow = Idle condition Green = Toggles Yellow/Green with Activity
RD	Receive Data to 1001MC from LAN Yellow/Green	Yellow = Idle condition Green = Toggles Yellow/Green with Activity

Power LED Indicator

The power LED shows the power status of the Model 1001MC

TABLE 1-2. Power LED Indicator		
LED	Function/Color	Description
Power	Power Green	On = Power is ON Off = Power is OFF

HeartBeat LED Indicator

TABLE 1-3. Poll LED Indicator		
LED	Function/Color	Description
Poll	Heartbeat Yellow	Toggles when packet TX is the on the Bus (backplane)

Fault LED Indicator

TABLE 1-4. Fault LED Indicator		
LED	Function/Color	Description
Fault	Fault Red	On = Signals hardware fault Off = No hardware fault

PPP LED Indicator

PPP will be included in future releases as a software upgrade to the 1001MC.

Getting Started

Table of Contents

Booting the 1001MC	2-2
--------------------------	-----

Booting the Model 1001MC

NOTE: If you are starting the Model 1001MC for the first time, you must log in via the rear panel RS-232 Configuration port and set the IP address, Subnet Mask, and Default Gateway. To complete this section you will need a VT-100 terminal or terminal emulator, a Null modem cable, an IP address for your box, a Subnet Mask for your box, and the IP address of the Default Gateway for your LAN.

NOTE: The configuration port on your 1001MC is a DTE, which requires a null modem or equivalent cable when connecting to a terminal.

1. Using personal computer communications software (Procomm, Windows Terminal, BitCom, PC Anywhere, etc.), set the configuration of your communications software to the following parameters:

Data Rate:	19,200 bps
Async. Character Format:	8 Data Bits, 1 Stop Bit, No Parity
Terminal Emulation:	VT-100 (or similar) terminal emulation

2. Connect the RS-232/V.24 port of the terminal to the rear panel RS-232 configuration port of the 1001MC through a null-modem. The RS-232 port is configured as Data Terminal Equipment (DTE).
3. Turn On the rack system or install your Model 1001MC front card.
4. After the rack system is turned on, it will enter a series of diagnostic tests to exercise the internal sub-systems in the unit. Halt the power up sequence in order to enter a new IP address, mask, and default gateway into the box. Press **b** three times when you see the following set of commands:

DRAM: Configure Complete
FLASH: Configure Complete
Boot Version May 11 1999 14:44:24
Validating operation code
Valid operational code, Hit **b three times to stop operational boot**

5. After pressing **b** three times the system will boot into the setup screen below.

```
Timer Started May 11 1999 14:44:24
Timer installed
Clock installed
Trying the console

---Ethernet Hardware---
  Address: 00.a0.ba.00.01.71
---Current IP settings---
  IP:      192.168.200.1
  Mask:    255.255.255.0
  Gateway: 209.49.110.1
Change IP settings (y/n)?
```

6. Type **Y** to change the IP address. The box will now prompt you for a new IP address, mask, and default gateway as shown in the following screen capture.

```
---Current IP settings---
  IP:      209.49.110.188
  Mask:    255.255.255.0
  Gateway: 209.49.110.1
Change IP settings (y/n)? y
User Set IP:    209.49.110.188
User Set Mask:  255.255.255.0
User Set Gateway: 209.49.110.1
---Settings to save---
  IP:      209.49.110.188
  Mask:    255.255.255.0
  Gateway: 209.49.110.1
Save these settings (y/n)? Y
```

7. After entering the information, the system will prompt you to save the IP settings. Type **Y** to save these settings.
8. Next, the Model 1001MC will prompt you (see below) for changes to the hardware revision that your unit requires. In most cases you should select 'N' to keep the current revision. The hardware revision should only be changed if you are upgrading to the latest firmware release.

```
---Hardware Initialization---
  Current Hardware Revision B
  Change Hardware Revision (y/n)? n
```

9. The power will need to be recycled to reboot the system with the new settings. After your system reboots, log into the box using a standard web browser from your network.

Installing the Model 1001MC RS-232 Daisy Chain Port

Using the Model 1001MC RS-232 Daisy Chain Port and an EIA-510 cable, your Model 1001MC can manage up to seven additional racks. Each daisy chained rack requires only one Model 1001CC Controller Card. The card allows one Model 1001MC to control up to 120 NetLink rack card modems and their remote CPE devices. This section describes how to connect your Model 1001MC to additional racks, using the Model 1001CC Controller Card.

If you plan to build your own RS-232 to EIA-561 converter to connect the Model 1001MC to the Model 1001CC, please refer to the 1001CC manual for pinouts of the EIA 561 interface.

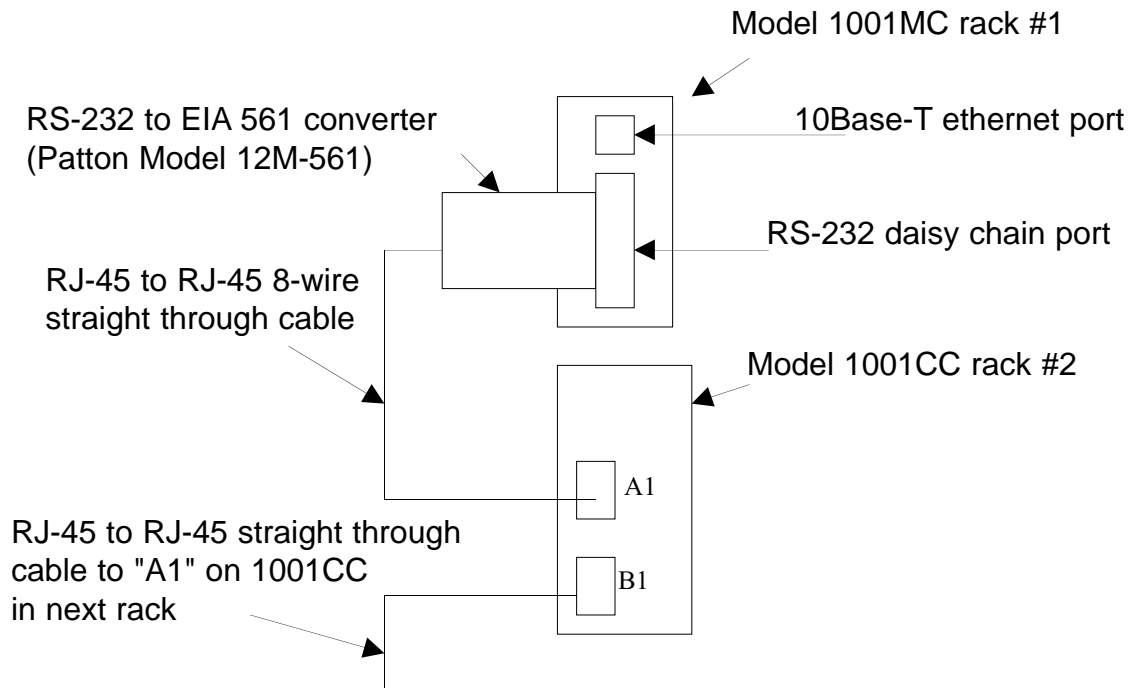

Setting the Address Range for Your NetLink Modems

The Model 1001MC POLLS the system looking for NetLink Modems. If the address of the NetLink modem is not configured or does not match the rack that it is installed in, the Model 1001MC may not find the card. The address range that is POLLED is determined by the configuration of the system. The system administrator must make sure that the software configuration within the Model 1001MC matches the hardware configuration of the system.

The Model 1001MC uses the number of power supplies in the system to determine what the address range of the individual racks will be. The number of power supplies installed in each rack is entered on the Modem Information page. If the system is set for two power supplies installed, the 1001MC will automatically set the number of Slots Available (displayed on the Modem Information page) in the chassis to 13. If the system is set for a single power supply installed, the 1001MC will automatically set the number of Slots Available in the chassis to 15.

Using this information, the Model 1001MC will POLL the specified address range in each rack. Thus, in a single power supply system, the address range for Rack #1 (the rack with the 1001MC installed) will be from address 1 to address 15 (NOTE: the 1001MC is always address 0). The 1001MC will then begin POLLing Rack #2 on the daisy chain port starting from address 16. In a redundant power supply system, the address range for Rack #1 (the rack with the 1001MC installed) will be from address 1 to address 13. The 1001MC will then begin POLLing Rack #2 on the daisy chain port starting from address 14.

The daisy chained racks are setup in the same manner with 13 addresses being available in a redundant system and 15 addresses being available in single supply system. When you disable a rack the addresses are still set aside for that rack space. If a power supply is removed, the addressing will not change unless you make the change through the 1001MC web pages. This allows easy service of the power supplies.

Configuring Your NetLink Modems for Installation

The Model 1001MC uses an internal bus to communicate with the NetLink modems installed in your system. It is required that the NetLink modem rear card should have Fame GND connected to Signal GND through a 100 Ohm resistor. This is done by setting a jumper on the rear card of your modem. Please refer to the manual that was shipped with your unit for more information on this jumper setting.

Using the Internal HTTP/HTML Management Pages

Table of Contents

Introduction to the Internal HTTP/HTML Management Pages.....	3-1
Logging into the HTTP/HTML Pages.....	3-2
HTTP/HTML and SNMP Object Format	3-2
Saving HTTP/HTML Object Changes	3-3
Help Screens	3-3
HOME	3-7
Box Information	3-8
Operating Status Variables	3-9
Immediate Actions	3-10
System Level Information	3-11
Modem Information	3-13
Slot Configuration	3-16
System Information	3-18
System Log.....	3-20
System Log Modify	3-21
System Log: Volatile Memory	3-23
System Log: Non-Volatile Memory	3-24
Software Upgrades for NetLink Modems	3-25
About 1001MC.....	3-26

3.0 HTTP/HTML Management

Introduction to the Internal HTTP/HTML Management Pages

This chapter explains how to use the internal HTTP/HTML management pages to manage your Patton NetLink System. The system can also be managed by using an SNMP Network Management Station using a standard SNMP software package or MIB walking tool. To use the Model 1001MC HTTP/HTML management pages, you must first define the LAN IP Address, and LAN Subnet Mask for the 1001MC. If you have not done so, please return to Chapter 2. Getting Started, to do so.

Logging Into the HTTP/HTML Pages

To log into the HTTP/HTML Management pages, you must enter the IP address as the URL (Universal Resource Locator) into a World Wide Web Browser. This address is the same address that you entered in **Chapter 2. Getting Started.**

http://abc.def.ghi.jkl

This will cause your web browser to ask for user name and password. There are two administration passwords associated with the operation of your 1001MC. They are:

1. **superuser**
2. **monitor**

The **superuser** password allows full permission to change and view any parameters in the 1001MC. The **monitor** password allows full viewing of any non-password oriented variables. Change these passwords immediately after initial configuration to avoid security breaches. Figure 3-1 shows the 1001MC s login screen.

Figure 3-1. Model 1001MC Login Screen

I.D. Connect to 209.168.15.12 as:

Name:

Password:

Realm: 1001MC

Remember Password

HTTP/HTML and SNMP Object Format

In Chapter 3, we shall describe variables on each of the internal HTTP/HTML pages. These variables will include brief descriptions of either the Patton Enterprise MIB or the applicable SNMP MIB. The format of the variables will look like this:

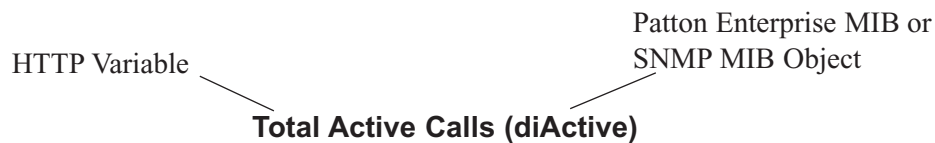

Saving HTTP/HTML Object Changes

After making changes to any 1001MC specific variables, you must save the changes in order to store them into flash. If the changes are not saved, they will be lost after the next power cycle.
NOTE: Changes you make to the 1001MC configuration parameters that deal with the NetLink function cards will automatically be saved in the function card flash memory after the configurations are complete.

1. Make the change to the parameter
2. Select **Submit**
3. Return to the HOME screen
4. Select **Record Current Configuration**

Help Screens

The Model 1001MC web pages have built in help screens which allow you to get information about the variables that are being described. Each web page contains several headings that describe the section that is being defined. Some of the headings are hyperlinks to the help screen for that page. The new window will automatically scroll to the help area that was requested. You may also scroll through this page to view help information about other sections of the page. In some cases, the headings for the tables will be shown as hyperlinks, these hyperlinks, work the same as was previously discussed, showing the help screen for that column of the table.

HTTP/HTML Web Page Navigation

This section describes how to navigate the internal HTTP/HTML web pages on the Model 1001MC. The diagram below shows how all of the web pages are linked together. Following the diagram, there is a brief description of each page. Continuing on through this chapter gives a more detailed description of each web page and the options that are available in that page.

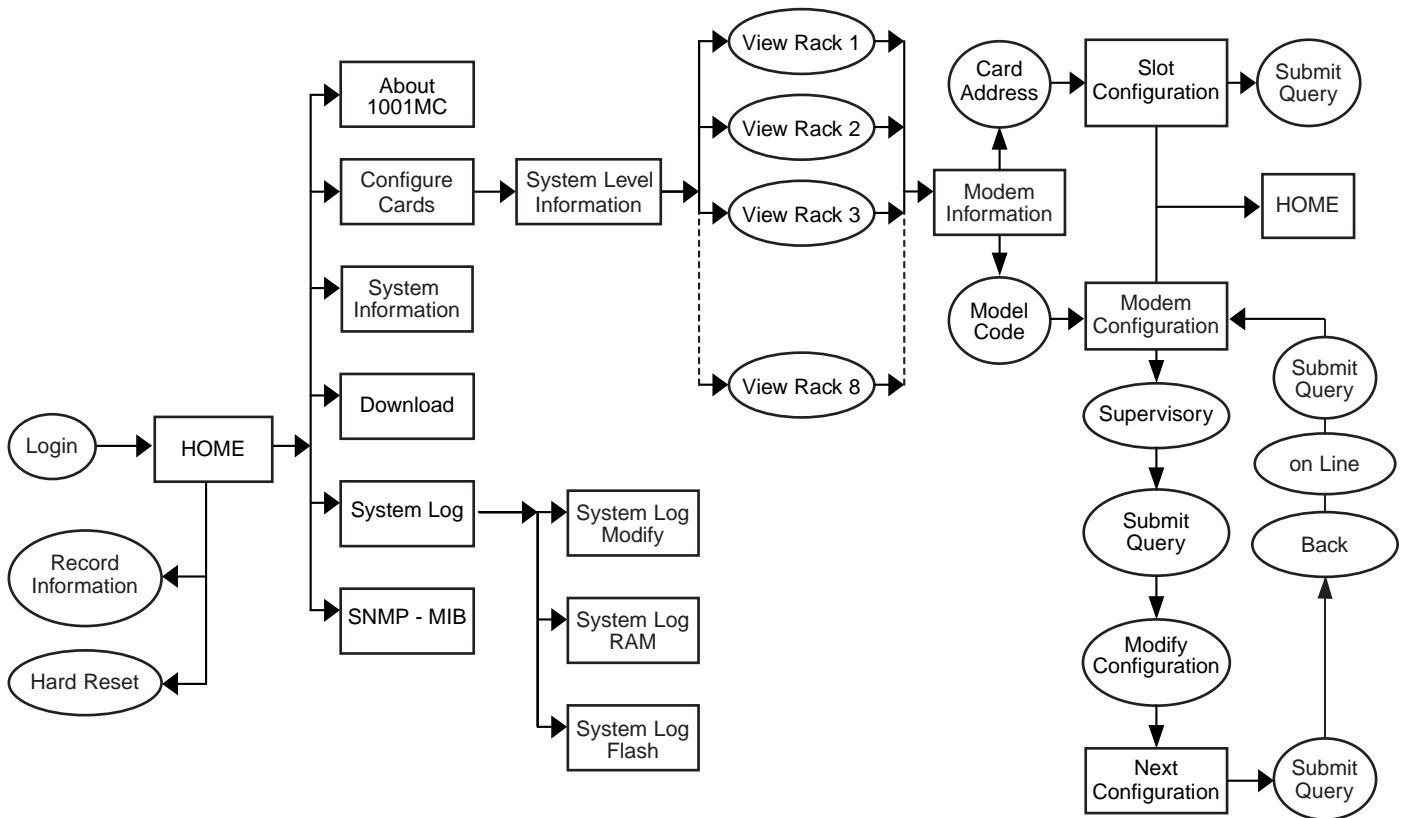

Login: After typing the IP address into your web browser as the URL, the Model 1001MC will present the "login" screen. The Model 1001MC has two levels of password protection, superuser and monitor. The superuser password level will allow you to view statistics and make configuration changes to the system. To log in as a superuser, type the word "superuser", all lower case, as the password to the login. The monitor level password allows you to view statistics, but it will not allow you to make any configuration changes. To log into the system at the monitor level, type "monitor", all lower case, as the password.

The "superuser" and "monitor" passwords are set in the unit as the default passwords. During your initial setup, change the passwords. After logging into the box, the system will display the HOME page.

Home: The HOME page displays a quick overview of the system including; error and warning indications, software information, box names, number of modems installed, etc. This page allows you to log into the box, get a quick look at the system, and leave if there are no situations presented that require further attention.

On the left side of the HOME page is the Navigation View. The list on the left side of the screen allows you to navigate to any page from this point. The navigation page will always be available to you so you can change from one page to the next.

Two additional push buttons are located on the bottom of the HOME page. The "Record Current Configuration" button allows you to store and configuration changes made to the box. NOTE: If configuration changes are not stored into memory, they will be lost if the unit is powered down. The "Hard Reset" button forces the 1001MC to perform a reset. This will not reset the individual cards in the rack only the 1001MC. If you would like to perform a hardware reset on the individual cards please refer to the Slot Configuration page.

About 1001MC: The About 1001MC page gives a second overview of the system. This page give a little more hardware information about the operation of the unit. This page also contains contact information about Patton Electronics.

Configure Cards: The Configure Cards hyperlink will bring you to the System Level Information page. This page is the starting point for the configuration and management of your Patton NetLink Modems. This page allows you to quickly identify potential problems and view statistics on a per rack basis. You can also disable racks from this level.

From this page, you can select a View Rack hyperlinks that will bring up the Modem Information Page for the selected Rack.

Modem Information Page: The Modem Information Page consists of a table that displays top level information about the cards installed in the selected rack. These items include; model codes, user ids, errors and warning, and circuit ids. This page also allows you to gain information about the number of cards and power supplies in the rack.

From this page there are two hyperlinks that can be selected that will give you detailed information about a specific modem. These are the Slot Configuration hyperlink, shown as the address of the card in the table, and the Modem Statistics hyperlink, shown as the local model code.

Slot Configuration: The slot configuration page allows you to setup specific information about the modem installed. From the page, you can change the User Ids, Circuit Ids, and the Error and Warning Indications. From this page, you can also clear errors and warning and perform a hardware reset on the modem installed in the rack.

Modem Configuration: The Modem Statistics page shows the current configuration and statistical state of the local and remote modem installed at the selected address. From this page, you can place the card into the superVisoryMode. Once the card is in this mode, the web page will display a hyperlink that will allow you to enter the Modem Configuration Page.

Modem Configuration Page: The Modem Configuration page allows you to change the configuration of the local and remote modems installed at the selected address. This page can also be used to place the cards into test modes. Once the configuration has been setup, submit the changes, and then place the

modem back into the onLine state. This is done in the Modem Statistics page discussed earlier. NOTE: The configuration changes that are made will not be implemented in the cards until the unit is placed back into the onLine state.

System Information: You can navigate to the System Information page by selecting the hyperlink along the left side of any page. The System Information page allows you to setup the IP information, box information, and password information for the system. It is recommended that you change your passwords immediately after installing your Model 1001MC to insure security for your network.

Download: The DownLoad page allows you to perform software upgrades on the NetLink Rack Card Modems installed in the system. New software for the modems can be obtained from Patton Electronics and uploaded into the 1001MC system through an ftp. The software can then be sent from the Model 1001MC to the cards installed.

System Log: The System Log page allows you to view the Syslog Messages. Syslog Messaging is a reporting tools used in the Model 1001MC to log run time operations. There are several levels of messages and you can set the system to report only the messages above a certain level. From this page, you can reach one of three different web pages: Modify , Volatile Memory, and Non-Volatile Memory.

Syslog - Modify: The Syslog-Modify web page allows you to setup the configuration for the Syslog messaging system. You can set variables such as the IP address of a Syslog Daemon and priority levels for each of the messaging facilities.

Syslog - Volatile Memory: The Syslog - Volatile Memory page displays Syslog messages that have been sent to the Volatile Memory section of the messaging system. The messages stored here will be lost if the system is re-booted.

Syslog - Non-Volatile Memory: The Syslog - Non-Volatile Memory page displays Syslog messages that have been sent to the Non-Volatile Memory section of the messaging system. The messages stored here will be stored in Flash Memory and will be available if the system is re-booted or power is lost.

SNMP: The SNMP web page has been made available to allow you to download the Patton Enterprise MIBs for the Model 1001MC. These MIBs will be required if you plan to manage the system using a NMS system instead of the web page manager.

HOME

The HOME page is the first HTTP/HTML screen that you will reach after you log into the Model 1001MC (See Figure 3-2, below). From the HOME page you may monitor the current system status, save any system changes or reset the system without powering off the rack system. Following Figure 3-2 is a description of each variable on the screen.

Figure 3-2. HOME Page

The screenshot displays the Patton Electronics HOME page. On the left is a vertical navigation menu titled "1001MC CONFIGURATION MENU" with links for HOME, About 1001MC, Configure Cards, System Info, Download, System Log, and SNMP. The main content area features the Patton Electronics Co. logo at the top. Below the logo is a table of system information:

Software Version:	2.0.29
Software Date Code:	Jun 15 1999 09:26:24
Box Name:	Tech Test Unit
Box Contact:	Patton Electronics (301) 975-1000
Box Location:	QuadX Bench
Running Since Last Boot:	0 days 3 hrs 39 min 52 sec

Below this table is the "STATUS OF Tech Test Unit" section, which contains another table:

Total System Slots Available:	13
Total Active Slots:	2
Total System Warnings:	0
Total System Errors:	2

At the bottom of the page, under the heading "IMMEDIATE ACTIONS", there are two buttons: "Record Current Configuration" and "Hard Reset".

Box Information

There are six system variables which describe information about the 1001MC. These variables are shown in 3-3, and are described in the section below.

Figure 3-3. Box Information

Software Version:	2.0.29
Software Date Code:	Jun 15 1999 09:26:24
Box Name:	Tech Test Unit
Box Contact:	Patton Electronics (301) 975-1000
Box Location:	QuadX Bench
Running Since Last Boot:	0 days 3 hrs 39 min 52 sec

Software Version (boxSoftwareVersion) This variable defines the version of the software currently running in the Model 1001MC. The Model 1001MC can be software upgraded using an ftp download. More information about the software download can be found in Chapter 2 Getting Started.

Software Date Code (boxDateCode) This variable defines the date and time the software was compiled.

Box Name (boxName) This variable displays a user defined string that represents the name of the box. This variable can be changed by the user in the System Info web page.

Box Contact (boxContact) This variable displays a user defined string that represents the contact for the box. You can change this variable in the System Info web page.

Box Location (boxLocation) This variable displays a user defined string that represents the location of the box. You can change this variable in the System Info web page.

Running Since Last Boot (boxUpTime) This variable tells you how long the Model 1001MC has been running since it was last reset.

Operating Status Variables

There are four system variables which describe the immediate operating status of the NetLink modems installed in the rack. These variables are shown in 3-4 below, and are described in the section below.

Figure 3-4. Operating Status Variables

Total System Slots Available:	13
Total Active Slots:	2
Total System Warnings:	0
Total System Errors:	2

Total System Slots Available (totalConfigSlots) This read-only variable defines the largest address that the system will POLL (address 1 to totalConfigSlots). Any NetLink modem with an address outside of this range will not be found by the Model 1001MC.

Total Active Slots (totalActiveSlots) This read-only variable defines the number of NetLink modems currently installed in the system. As the Model 1001MC brings the modems online this number is incremented. After a card is removed from the system, this number is decrement.

Total System Warnings (boxWarningNumber) This variable defines the number of warnings that are currently outstanding in the system. This number includes warnings that have been generated from the NetLink modems as well as the Model 1001MC itself. If this number is greater than zero, this field will be highlighted in yellow to notify you that the warning exists. Warnings are cleared through the [Configure Cards](#) web page for the system, or the [Slot Configuration](#) page for the individual modems. You can view the System Log page to examine the source of the warnings.

Total System Errors (boxErrorNumber) This variable defines the number of errors that are currently outstanding in the system. This number includes errors that have been generated from the NetLink modems as well as the Model 1001MC itself. If this number is greater than zero, this field will be highlighted in red to notify you that the errors exists. Errors are cleared through the [Configure Cards](#) web page for the system, or the [Slot Configuration](#) page for the individual modems. You can view the System Log page to examine the source of the warnings.

Immediate Actions

There are several immediate actions which can be executed on the Model 1001MC, when in superuser mode (refer to Figure 3-5, below), which will cause the box to act according to the descriptions below.

Figure 3-5. Immediate Actions

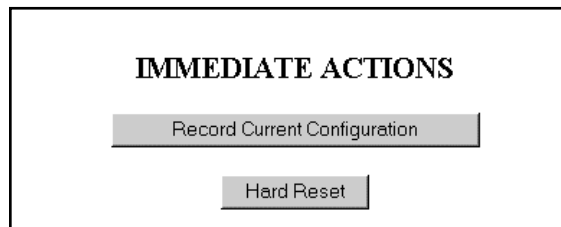

Record Current Configuration SELECTING the RECORD CURRENT CONFIGURATION button causes the current configuration to be stored in FLASH memory. Any changes made to the Model 1001MC configuration are stored in non-volatile RAM first. This allows you to set the box up with a working configuration before making the configuration permanent. Changes become permanent when you select RECORD CURRENT CONFIGURATION. You will lose all changes not stored to FLASH the next time the 1001MC is re-booted unless you store them.

Hard Reset HARD RESET causes the 1001MC to restart. When you select HARD RESET, the 1001MC confirms that you want to execute this command. Then, the 1001MC will re-initialize the interfaces, and re-load configuration parameters from FLASH.

NOTE: The Hard Reset will not perform a hardware reset on the modem in the system. This can be done in the [slot configuration](#) web page for the individual cards.

System Level Information

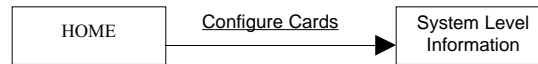

The Configure Cards hyperlink from the HOME page will bring you to the System Level Information page. Figure 3-2 displays a portion of the information page for the NetLink system being managed. The System Level Information page contains statistical information about the entire system and explains how that information is broken down among the racks. Each rack can be enabled or disabled from this level. When a rack is disabled, the 1001MC stops POLLing the addresses contained in the specified rack. The 1001MC's ability to stop POLLing is useful when installing less than eight racks or when taking cards OffLine in order to perform servicing. The modems installed in the system will continue to operate at the last setting provided. This page also allows you to clear alarms on a per rack or system basis. Each rack view also contains a View Rack hyperlink to the Modem Information page.

Below is a representation of the System Level Information page (Fig. 3-2). Following Fig. 3-2 is a description of the variables contained within the System Level Information page.

Figure 3-2. System Level Information Page

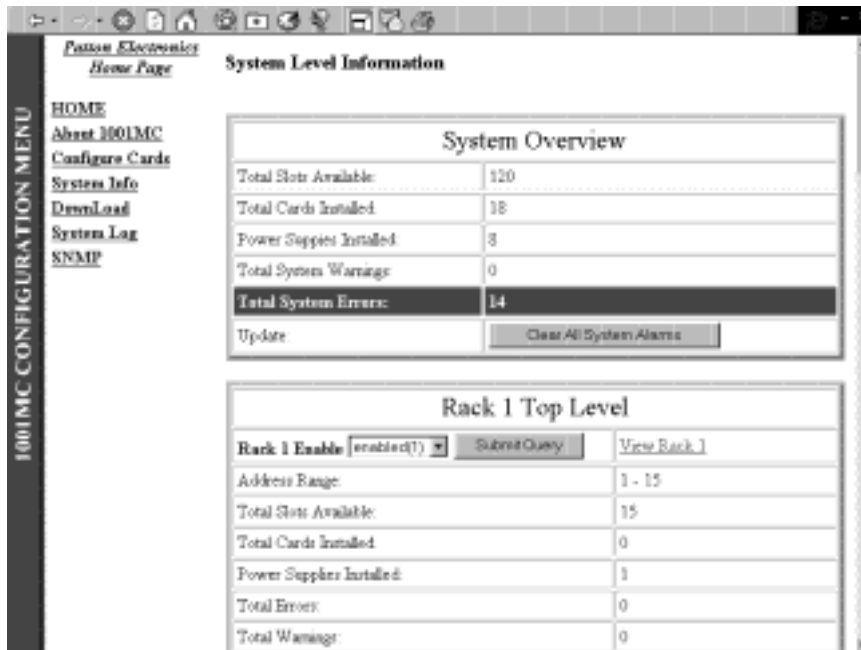

Total Configurable Slots (totalConfigSlots): Read only, defines the amount of configurable slots available in the system.

Total Cards Installed (totalActiveSlots): Read only, defines the amount of cards the system has found.

3.0 HTTP/HTML Management

Total Power Supplies Installed (boxPowerSupplies): Read only, defines the amount of power supplies installed in the system.

Total Number of Warnings in the System (boxWarningNumber): Read only, defines the amount of warnings that have been generated in the system.

Total Number of Errors in the System (boxErrorNumber): Read only, defines the amount of errors that have been generated in the system.

The following variables are used by each rack in the system. Replace the "X" shown in the variable name with the appropriate rack number to label the specific variable name (i.e. rack2Enable).

Enable Disable Rack (rackXEnable): Read/write, enables or disables a rack for use by the system. There are two main uses for these variables. When your system configuration requires less than the maximum number of racks, all un-installed racks should be disabled. The 1001MC will not POLL the address range for a rack that is disabled, this will decrease the POLLing time for the system. If you would like to remove cards from the rack without the alarm notification you can disable the rack.

Rack Minimum Address (rackXMinAddr): Specifies the minimum address that will be polled for the defined rack (based on the maximum address of the previous rack).

Rack Maximum Address (rackXMaxAddr): Specifies the maximum address that will be polled for the defined rack (based on the minimum address of the rack and the number of power supplies installed).

Number of Slots Available (rackXSlotsAvailable): Defines the number of slots available for the rack (based on the number of power supplies installed in the rack).

Number of Cards Installed (rackXCardsInstalled): Displays the number of cards that the system has found.

Number of Power Supplies (rackXPowerSupplies): Sets the number of power supplies installed in the rack (used to determine the addressing range for the rack).

Number of Errors (rackXErrorNumber): Shows the number of errors that have been reported by the system for this rack.

Number of Warnings (rackXWarningNumber): Shows the number of warnings that have been reported by the system for this rack.

Clear System Alarms (clearAlarms): Read/write, can be used to clear alarms on a per card basis or for the entire system.

Modem Information

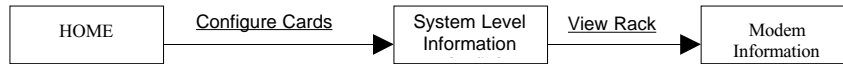

The Modem Information screen displays an overview of the NetLink rack that is being managed. This page will display statistical information, such as errors and warnings on a per card basis, and identification information, such as model codes and user IDs. Figure 3-6, below, shows the Modem Information page, a description of each variable follows.

Figure 3-6. Modem Information

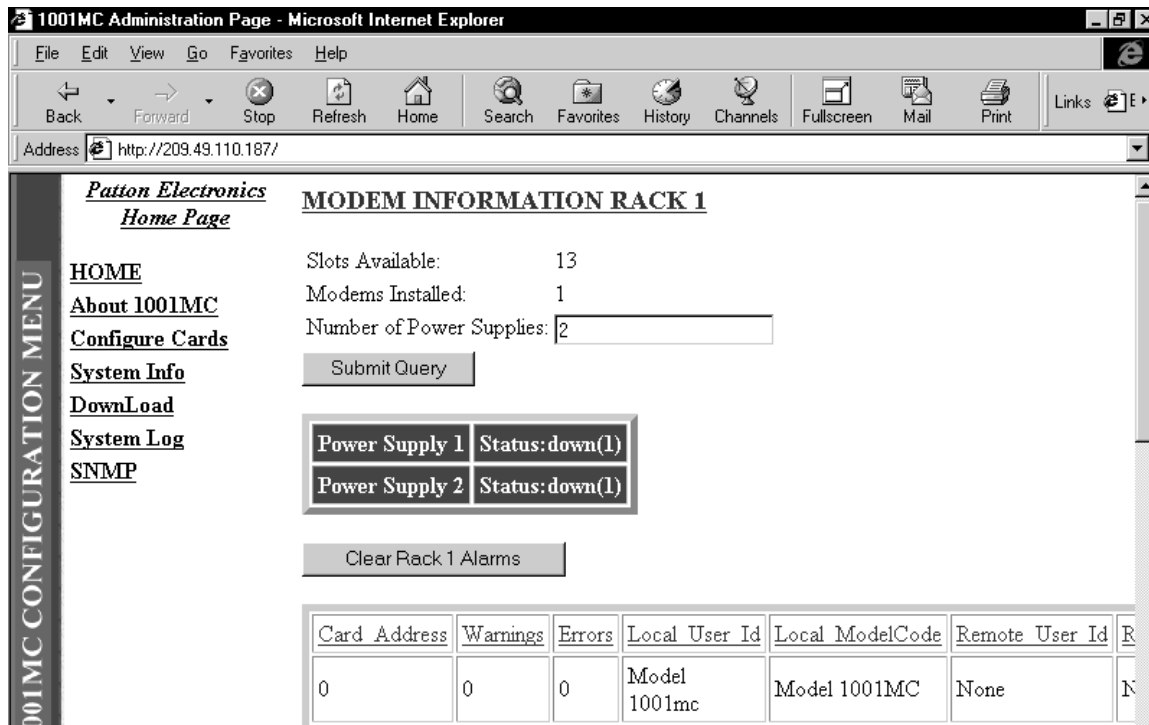

3.0 HTTP/HTML Management

Card Display Type (listType) Defines how the current web page will be displayed. You can choose to display all of the slots that are available to the Model 1001MC, or he can choose to display only the slots that are currently populated with NetLink modems.

Number of Power Supplies (boxPowerSupplies) Defines the number of power supplies that the Model 1001MC will monitor for availability. In the case of a redundant power supply system, you should set this variable to 2, this will inform the Model 1001MC that there should be 2 power supplies in the system, if it finds any less than that an error will be reported and the failed power supply will be highlighted in red.

Power Supply 1 (boxPower1Down) Defines the status of the Power Supply 1. If Power Supply 1 fails, this field will be highlighted in red and generate a system error notifying you of the failure. When looking at the front of your rack, Power Supply 1 is on the right side

Power Supply 2 (boxPower2Down) Defines the status of the Power Supply 2. If power supply 2 fails, this field will be highlighted in red and generate a system error notifying you of the failure.

The following information describes each column of the modem table. Note: each table heading is a hyperlink to a help page that contains information about the column.

Card Address (nmsSlotID) Defines the address of the card. The Model 1001MC will POLL the cards using the addresses listed in the "Card Address" column. If a modem is found with the same address, it will be displayed in that row. The address of the card is setup using the dip-switches on the card. For more information about setting the address of a card, please refer to the appropriate NMS version of the manual for the specific NetLink modem. The address is also a hyperlink to the [Slot Configuration](#) page. This page can be used to set slot specific information about the card.

Warnings (warningCount) Displays the warnings that are associated with each modem installed in the system. When warnings are present, this field will be highlighted in "yellow" and the number of warnings will be listed. For more information on the cause of the warning, you should view the System Log. Warnings will be highlighted in yellow in the log. The warnings for the slot can be erased in the Slot Configuration page. Note, the System Log will still display the warnings even after the number is cleared.

Errors (errorCount) Displays the errors that are associated with each modem installed in the system. When errors are present, this field will be highlighted in "red" and the number of errors will be listed. For more information on the cause of the error, you should view the System Log. Errors will be highlighted in red in the log. The errors for the slot can be erased in the Slot Configuration page. Note, the System Log will still display the errors even after the number is cleared.

Local User Id (localUserID) User supplied string that defines the NetLink modem installed in the rack. The string is stored in non-volatile flash within the NetLink modem. If the address of the modem is changed, the User ID will move to the new slot. The string can be up to 10 bytes long and can be changed or reset within the Slot Configuration page.

Local Model Code (localModelCode) This column displays the model code of the NetLink modem installed at the specified address. The Model Code is also a hyperlink into the configuration of the NetLink modem and its remote unit.

Remote User Id (remoteUserID) User supplied string that defines the unit at the end of the link. The string is stored in non-volatile flash within the unit. If the unit is moved, the User ID will move to the new slot. The string can be up to 10 bytes long and can be changed or reset within the Slot Configuration page.

Remote Model Code (remoteModelCode) This column displays the model code of the NetLink modem at the far end of the link.

Local Circuit ID (localCircuitID) The circuit ID is a 40 byte string that is stored in non-volatile flash within the Model 1001MC. This string can be changed from the Configure Cards web page or from the Slot Configuration web page.

Remote Circuit ID (remoteCircuitID) The circuit ID is a 40 byte string that is stored in non-volatile flash within the Model 1001MC. This string can be changed from the Configure Cards web page or from the Slot Configuration web page.

Slot Configuration

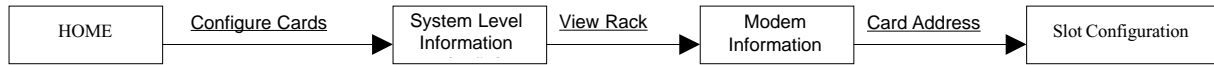

The Slot Configuration page (Figure 3-7) allows you to make slot specific configuration changes that are not product specific. Following Fig. 3-7 is a description of each variable.

Figure 3-7. Slot Configuration Page

Patton Electronics Home Page

SLOT CONFIGURATION PAGE

Card Address: 1
Local Model Code: model1095RC(1)

Card Identification Information

Local User ID:

Remote User ID:

Card Identification Information

Local Circuit ID:

Remote Circuit ID:

Alarm Information

Card Identification Information:

Local User Id (localUserID) 10 byte user supplied string that defines the NetLink modem installed in the rack. The string is stored in non-volatile flash within the NetLink modem.

Remote User Id (remoteUserID) 10 byte user supplied string that defines the remotely connected modem. The string is stored in non-volatile flash within the NetLink modem.

Local Circuit ID (localCircuitID) The circuit ID is a 40 byte string that is stored in non-volatile flash within the Model 1001MC.

Remote Circuit ID (remoteCircuitID) The circuit ID is a 40 byte string that is stored in non-volatile flash within the Model 1001MC.

Alarm Information:

Clear Slot Alarms (resetStatus) Selecting this push button erases the alarms (errors and warnings) associated with the specified slot. Note: The errors and warning will still be listed in the System Log.

Hardware Reset (resetStatus) Selecting this push button will force the associated modem to perform a hardware reset.

Card Lost Indication (cardLostIndication) This variable allows you to choose what type of indication will be made if a modem is removed from the management system. Three choices are currently available: error, warning, and none.

Line Down Indication (lineDownIndication) This variable allows you to choose what type of indication will be made if a modem reports a line down scenario. Three choices are currently available: error, warning, and none.

System Information

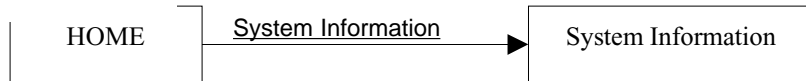

The System Information page displays the current setting for the system. This page allows you to setup parameters defining password protection and the network address. The page is shown below, a description of each variable follows.

Figure 3-8. System Information

1001MC CONFIGURATION MENU	<u>Patton Electronics</u>	
	<u>Home Page</u>	
	<u>HOME</u>	CURRENT SYSTEM INFORMATION
	<u>About 1001MC</u>	IP Address: 209.49.110.187
	<u>Configure Cards</u>	IP Mask: 255.255.255.0
	<u>System Info</u>	Current Gateway 209.49.110.1
	<u>DownLoad</u>	Modifying the IP addressing
	<u>System Log</u>	IP Address: <input type="text" value="209.49.110.187"/>
	<u>SNMP</u>	IP Mask: <input type="text" value="255.255.255.0"/>
		Gateway: <input type="text" value="209.49.110.1"/>
	<input type="button" value="Submit Query"/>	
	Box Contact Information	
	Box Location: <input type="text" value="QuadX Bench"/>	
	Box Name: <input type="text" value="Tech Test Unit"/>	
	Box Contact: <input type="text" value="Patton Electronics (3)"/>	
	<input type="button" value="Submit Query"/>	
	SNMP and HTTP Password Information	
	Superuser Password: <input type="text" value="superuser"/>	
	Superuser Password Verification: <input type="text"/>	<input type="button" value="Submit Query"/>
	User Password: <input type="text" value="monitor"/>	
	User Password Verification: <input type="text"/>	<input type="button" value="Submit Query"/>
	Background Information	
	Web Background Enabled: <input type="text" value="disableGraphics(0)"/>	

IP Address (boxIpAddress) This parameter defines the IP address of the box

IP Mask (boxIpMask) This parameter defines the IP mask of the box

Current Gateway (boxGateway) This parameter defines the current gateway for the network.

Box Location (boxLocation) User defined string that represents the location of the box. This variable is displayed on the HOME page.

Box Name (boxName) User defined string that represents the name of the box. This variable is displayed on the HOME page.

Box Contact (boxContact) User defined string that represents the contact for the box. This variable is displayed on the HOME page

Superuser Password (boxSnmpMasterPassword) This password will allow full access rights to the box (read-write). You should change this password by typing the new password into both the Password and Verification field and then selecting the "Submit" button. After entering the new password, you must store the configuration into memory from the HOME page.

User Password (boxSnmpMonitorPassword) This password will allow monitor access rights to the box (read-only). You should change this password by typing the new password into both the Password and Verification field and then selecting the "Submit" button. After entering the new password, you must store the configuration into memory from the HOME page.

Web Background Enable (boxBackgroundFlag) The Model 1001MC contains a background image that can be used while viewing the web pages. This variable tells the system whether to display the background information or not.

System Log

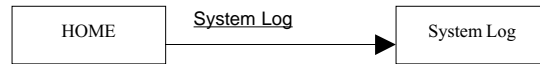

The System Log page gives an overview of the system logging functions. The system log is a messaging system that stores information about the system as it is running. This page contains three hyperlinks which allow modification and viewing of the system log messages. The variables associated with the system log will be defined within the context of these web pages.

Figure 3-9. System Log

1001MC CONFIGURATION MENU	<u>Patton Electronics</u> <u>Home Page</u>	SYSTEM LOG
		<u>Modify...</u> <u>Volatile Memory...</u> <u>Non-Volatile Memory...</u>
	<u>HOME</u>	SysLog Daemon IP Address: 209.49.110.157
	<u>About 1001MC</u>	SNMP Trap Daemon IP Address: 0.0.0.0
	<u>Configure Cards</u>	Min Priority for SysLog Daemon: priorityInfo(20)
	<u>System Info</u>	Min Priority for Console RS-232: priorityInfo(20)
	<u>Download</u>	Min Priority for Flash Storage: prioritySystem(80)
	<u>System Log</u>	Min Priority for SNMP Trap Daemon: priorityDisable(1000)
	<u>SNMP</u>	Min Priority for RAM: priorityOddity(40)
		Maintain Flash Storage: syslogFlashOK(0)
	Unix Facility: daemon(3)	

System Log Modify



The System Log Modify page allows you to modify the system log parameters. You can choose which messages will be sent to the available message logging functions.

Figure 3-10. System Log Modify

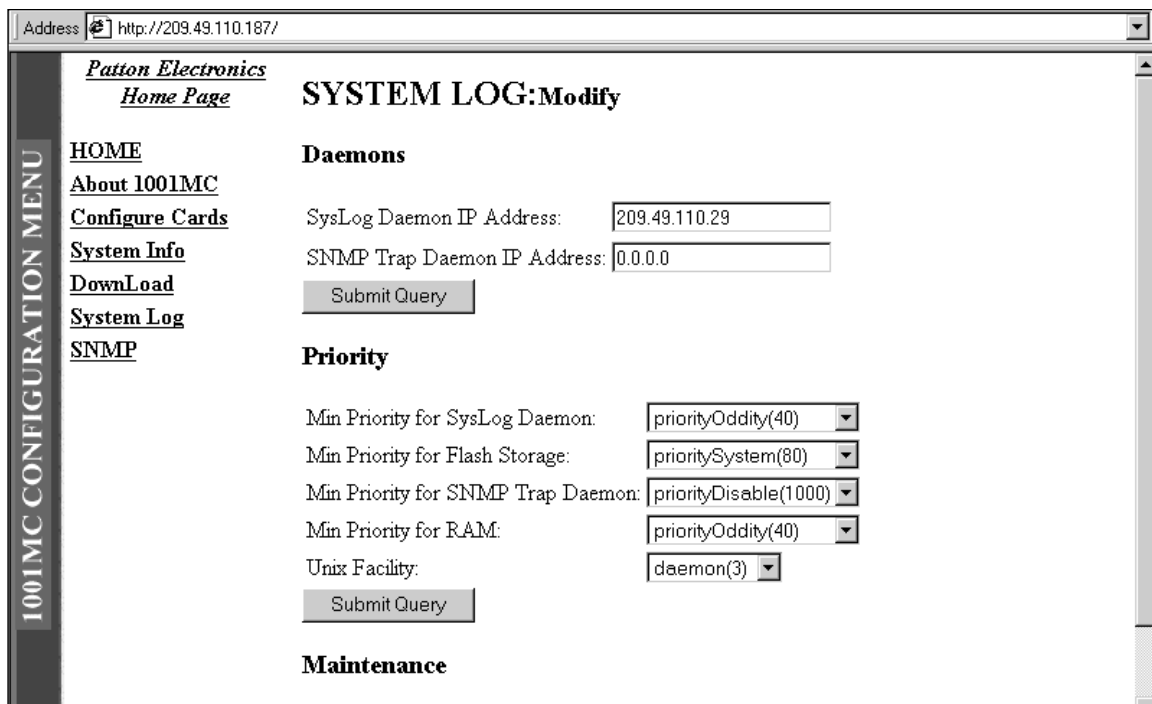

Daemons:

Syslog Deamon IP Address (syslogDeamonIP) The Model 1001MC can send messages over a network to a Syslog Daemon. This variable specifies the IP address that will be running the Syslog Daemon.

SNMP Trap Daemon IP Address (syslogTrapIP) NOT SUPPORTED AT THIS TIME. This variable is not supported in the present software version. Please check the Patton Electronics web site for software upgrades that will support this feature.

3.0 HTTP/HTML Management

Priority:

There are four separate outputs that accept syslog messages. Specify the minimum priority for a message that will be sent to that output. For most situations, set the outputs that are being used to `prioritySystem(80)`. For unused output mechanisms, set the priority to `priorityDisable(100)`.

Maintenance:

Maintain Flash Storage (`syslogFlashClear`) This variable is used to notify you about the status of the flash storage area. If the flash storage area is full this variable will read `"syslogFlashFull"`. The flash storage area can be erased by setting this variable to `"syslogFlashClear"` and selecting the "Submit Query" button.

SYSTEM LOG: Volatile Memory

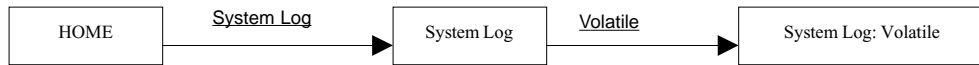

This page contains a log of messages that have been sent to the RAM storage area using the **Min Priority for RAM** variable in the Syslog Modify page. Messages stored here will be lost if the box reboots.

Figure 3-11. System Log Volatile Modify

1001MC CONFIGURATION MENU	<u>Patton Electronics</u> <u>Home Page</u>	
	SYSTEM LOG: Volatile Memory	
	System Up Time: 1 days 7 hrs 10 min 24 sec	
	Time	Message
	0 days 23 hrs 1 min 53 sec	box\box.c:Line Down Address 11
	0 days 23 hrs 4 min 6 sec	box\box.c:Card Lost Address 11
	0 days 23 hrs 4 min 10 sec	box\track.c:Card Found: Address 11
	0 days 23 hrs 5 min 23 sec	func1095\func1095.c:Line Up: Address 11
	0 days 23 hrs 17 min 52 sec	box\box.c:Line Down Address 11
	0 days 23 hrs 20 min 5 sec	box\box.c:Card Lost Address 11
	0 days 23 hrs 20 min 9 sec	box\track.c:Card Found: Address 11
	0 days 23 hrs 21 min 22 sec	func1095\func1095.c:Line Up: Address 11
	0 days 23 hrs 22 min 55 sec	box\box.c:Line Down Address 11
	0 days 23 hrs 25 min 8 sec	box\box.c:Card Lost Address 11
	0 days 23 hrs 25 min 12 sec	box\track.c:Card Found: Address 11
0 days 23 hrs 26 min 24 sec	func1095\func1095.c:Line Up: Address 11	
0 days 23 hrs 55 min 57 sec	box\box.c:Line Down Address 11	
0 days 23 hrs 58 min 10 sec	box\box.c:Card Lost Address 11	
0 days 23 hrs 58 min 15 sec	box\track.c:Card Found: Address 11	
0 days 23 hrs 59 min 27 sec	func1095\func1095.c:Line Up: Address 11	
1 days 0 hrs 8 min 27 sec	box\box.c:Line Down Address 11	
HOME		
<u>About 1001MC</u>		
<u>Configure Cards</u>		
<u>System Info</u>		
<u>DownLoad</u>		
<u>System Log</u>		
<u>SNMP</u>		

SYSTEM LOG: Non-Volatile Memory

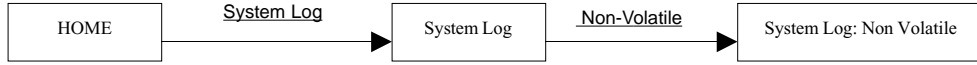

This page contains a log of messages that have been sent to the flash storage are using the **Min Priority for Flash Storage** variable in the Syslog Modify page. Messages stored here will be saved even if the box reboots. This page will show Warnings highlighted in yellow and Errors highlighted in red. When an error or warning is displayed somewhere in the web pages, this page will give a description of the error/warning. All information on this page is read-only except a single push button at the top of the page which is described in more detail below.

Figure 3-12. System Log Non-Volatile Memory

Patton Electronics
Home Page

HOME

About 1001MC

Configure Cards

System Info

DownLoad

System Log

SNMP

SYSTEM LOG: Non-Volatile Memory

System Up Time: 1 days 7 hrs 21 min 6 sec

Time	Message
0 days 23 hrs 1 min 53 sec	box\box.c:Line Down Address 11
0 days 23 hrs 4 min 6 sec	box\box.c:Card Lost Address 11
0 days 23 hrs 4 min 10 sec	box\track.c:Card Found: Address 11
0 days 23 hrs 5 min 23 sec	func1095\func1095.c:Line Up: Address 11
0 days 23 hrs 17 min 52 sec	box\box.c:Line Down Address 11
0 days 23 hrs 20 min 5 sec	box\box.c:Card Lost Address 11
0 days 23 hrs 20 min 9 sec	box\track.c:Card Found: Address 11
0 days 23 hrs 21 min 22 sec	func1095\func1095.c:Line Up: Address 11
0 days 23 hrs 22 min 55 sec	box\box.c:Line Down Address 11
0 days 23 hrs 25 min 8 sec	box\box.c:Card Lost Address 11
0 days 23 hrs 25 min 12 sec	box\track.c:Card Found: Address 11
0 days 23 hrs 26 min 24 sec	func1095\func1095.c:Line Up: Address 11
0 days 23 hrs 55 min 57 sec	box\box.c:Line Down Address 11
0 days 23 hrs 58 min 10 sec	box\box.c:Card Lost Address 11
0 days 23 hrs 58 min 15 sec	box\track.c:Card Found: Address 11
0 days 23 hrs 59 min 27 sec	func1095\func1095.c:Line Up: Address 11
1 days 0 hrs 8 min 27 sec	box\box.c:Line Down Address 11

Erase Flash Messages (syslogFlashClear) This push button will clear the messages listed on this page. This function can also be performed from the Syslog Modify page and has been added here for ease of use. Note, once message are erased they can not be recovered.

3-24

3-24

Software Upgrades for your NetLink Modems



The Model 1001MC has the facilities to download new software into your NetLink modems although not all of the NetLink modems are flash upgradeable. Please refer to the appendix of this manual that deals with your NetLink modem to see if software upgrades are supported.

In order to perform a software upgrade on your modem, please refer to the instructions on the Download web page.

About 1001MC

Thank you for purchasing Patton Electronics SNMP-managed products! We do appreciate your business. I trust that you find this user manual helpful in managing your system.

We manufacture one of the widest selections of data communications products in the world including CSU/DSU's, network termination units, powered and self-powered short range modems, fiber optic modems, interface converters, baluns, electronic data switches, data-line surge protectors, multiplexers, transceivers, hubs, print servers and much more. We produce these products at our Gaithersburg, MD, USA, facility, and can custom manufacture products for your unique needs.

We would like to hear from you. Please contact us in any of the following ways to tell us how you like this product and how we can meet your product needs today and in the future.

Web: <http://www.patton.com>
Sales E-mail: sales@patton.com
Support E-mail: support@patton.com
Phone - Sales (301) 975-1000
Phone - Support (301) 975-1007
Fax: (301) 869-9293
Mail: Patton Electronics Company
7622 Rickenbacker Drive
Gaithersburg, MD 20879 USA

We are committed to a quality product at a quality price. Patton Electronics is BABT and ISO 9001 certified. We meet and exceed the highest standards in the industry (CE, UL, etc.).

It is our business to serve you. If you are not completely satisfied with this product or service provided by Patton Electronics or its distributors, please let us know.

Appendix A - Model 1095NetLink- DSL SNMP

This document describes the management of a Model 1095 NetLink - DSL modem. This document is intended to be used in addition to the manual that you received with your unit. This document describes how to manage your Model 1095 using the Model 1001MC NetLink - NMS internal HTTP/HTML web engine and a standard web browser, the Patton Enterprise MIB that is associated with the Model 1095, and NetLink Plug-and-Play features that can be used with your modems.

Features

- Fully SNMP manageable local and remote units using the Patton NetLink-NMS Model 1001MC
- HTTP/HTML manageable local and remote units using the Patton NetLink-NMS Model 1001MC and a standard web browser
- NetLink Plug-And-Play allows easy startup of CPE units
- Software upgrades of 1095RC available using the Model 1001MC download feature
- DTE speeds nx64 to 2.3 Mbps
- DSL Distances on just two wires using mDSL technology
- 2-wire operation
- Standalone (QuikConnect), Rackmount, and Fixed Interface (1088) versions available
- Internal, external, and receive recover clocking options

1095NMS Description

The NetLink mDSL Model 1095 was developed to meet the needs of Internet Service Providers (ISPs), Incumbent Local Exchange Carriers (ILECs), Inter-Exchange Carriers (IXC), and PTTs that must achieve affordable broadband transmission over the existing copper infrastructure. As a symmetric DSL modem, the NetLink mDSL offers the same data rates in both directions over a single pair of regular telephone lines using Carrierless Amplitude and Phase (CAP) modulation. Featuring replaceable DCE-DTE interface modules and rear cards, the NetLink mDSL can be configured for a huge range interfaces including: Ethernet, Data and Voice, V.24/RS-232, V.35, RS-422/530, G.703, and X.21 applications. Line connection is made by an RJ-45 jack.

Specifically designed for use in the Patton NetLink system, when the NetLink mDSL is coupled with the Model 1001MC (NetLink-NMS) and the Patton Model 1001R14/16P rack system, the modems are fully SNMP manageable. SNMP management can be performed on both the local and remote units using a standard SNMP Network Management Station (NMS) or by using a standard web browser and the Model 1001MC's built in web server. You can view and change configuration variables, view statistical variables, and view error and warning indications. Using the NetLink system, you can also take advantage of the NetLink Plug-And-Play feature that is available in the NetLink mDSL modems. For more information on the NetLink Plug-And-Play, please refer to that section of this manual

Configuration and Management

This section describes the configuration and management of your NetLink mDSL modems using a Model 1001MC NetLink-NMS management card with built in HTTP/HTML web server. If you plan to manage your units using a standard Network Management Station (NMS) you can download the Patton Enterprise MIBs either through the SNMP web page on the Model 1001MC or visit the Patton web site.

There are three separate ways to setup your modems for communication: dip-switch controlled, dip-switch Plug-And-Play CP, and Netlink Plug-And-Play CP. The NetLink Plug Plug-and-Play setup is described in more detail on the following page. The dip-switched controlled setups are not described in this manual. Please refer to the manual that was shipped with your unit for more information on the dip-switch operation of your units or download the manual from the Patton website (www.patton.com).

NOTE: The applications described in the following sections are designed for a NetLink-mDSL rack card modem (CO configuration - Internal/External Clock) in a NetLink chassis with a Model 1001MC. At the remote end, a NetLink-mDSL stand alone unit (CP configuration - Receive Recover Clock) is connected as a Netlink Plug-And-Play CP. If your setup differs from this application, additional information may be needed to complete your setup. Please visit the Patton Electronics web site at www.Patton.com for a list of application notes and FAQs that are available for setting up your application. Or call Patton Electronics tech support at 301 975-1007 or email at support@patton.com.

Hardware Setup of your NetLink-mDSL Rack Card:

The Model 1001MC uses the internal bus bar connection to communicate with your NetLink modems. To ensure a reliable connection between the Model 1001MC and the Model 1095RC, set the rear cards on all modems to have Frame GND connected to Signal GND through a 100 Ohm resistor. For more information on making this connection, please refer to the 1095RC manual that was shipped with your unit.

The manual that was shipped with your NetLink-mDSL unit specifies switch S1 as "Reserved". This switch is actually used to set the address of the modem in the NetLink system. Each card in the chassis is given a unique address through the setting of switch S1. Note, the stand alone units are not given an address through the setting of a dip-switch, they will use the address of the rack card that they are connected to. The Model 1001MC sends "POLL" messages along the internal bus looking for cards installed in the system. Once a card is found it is placed "on-line" and communication with the management station can begin.

If the address of the NetLink modem is not configured or does not match the address range of the rack that it is installed in, the Model 1001MC may not recognize the card. The address range that is POLLED is determined by the configuration of the system. The system administrator must make sure that the software configuration within the Model 1001MC matches the hardware configuration of the system.

The Model 1001MC uses the number of power supplies in the system to determine what the address range of the individual racks will be. The number of power supplies installed in each rack is entered on the Modem Information page. If the system is set for two power supplies installed, the 1001MC will

automatically set the number of Slots Available (displayed on the Modem Information page) in the chassis to 13. If the system is set for a single power supply installed, the 1001MC will automatically set the number of Slots Available in the chassis to 15.

Using this information, the Model 1001MC will POLL the specified address range in each rack. Thus, in a single power supply system, the address range for Rack #1 (the rack with the 1001MC installed) will be from address 1 to address 15 (NOTE: the 1001MC is always address 0). The 1001MC will then begin POLLing Rack #2 on the daisy chain port starting from address 16. In a redundant power supply system, the address range for Rack #1 (the rack with the 1001MC installed) will be from address 1 to address 13. The 1001MC will then begin POLLing Rack #2 on the daisy chain port starting from address 14.

The daisy chained racks are setup in the same manner with 13 addresses being available in a redundant system and 15 addresses being available in single supply system. When you disable a rack the addresses are still set aside for that rack space. If a power supply is removed, the addressing will not change unless you make the change through the 1001MC web pages. This allows easy service of the power supplies.

If all of the bits of switch S1 are set to the "ON" position, then the unit will run completely from its dip-switch configuration. This can be useful for testing circuits independently of the management system. If an address is placed on the switch, the unit will boot from its stored flash configuration and begin looking for POLL commands from the Model 1001MC.

Switch S1 allows an 8 bit address to be assigned to a link. The following rules apply to setting the address. Bit S1-8 is the least significant bit. A bit set to "ON" is considered a "0". A bit set to "OFF" is considered a "1". Patton Electronics suggests that you set your addresses starting with address 1 at the far left of your rack (farthest away from the power supplies) and increment the numbers by one as you go from left to right. Setting the addresses in this manner will make configuration easier as you start using the web page management. An example of this is shown in table A-1.

Table A-1. Starting Address Setting

1 - 2 - 3 - 4 - 5 - 6 - 7 - 8 - 9 - 10 - 11 - 12 - 13 - NMS - PS2 - PS1

The following table A-2 shows the bit setting to configure the address.

TABLE A-2. Bit Setting to Configure the Address

Upper (Lower) Nibble	S1-1 (S1-5)	S1-2 (S1-6)	S1-3 (S1-7)	S1-4 (S1-8)
0	ON	ON	ON	ON
1	ON	ON	ON	OFF
2	ON	ON	OFF	ON
3	ON	ON	OFF	OFF
4	ON	OFF	ON	ON
5	ON	OFF	ON	OFF
6	ON	OFF	OFF	ON
7	ON	OFF	OFF	ON
8	OFF	ON	ON	ON
9	OFF	ON	ON	OFF
A	OFF	ON	OFF	ON
B	OFF	ON	OFF	OFF
C	OFF	OFF	ON	ON
D	OFF	OFF	ON	OFF
E	OFF	OFF	OFF	ON
F	OFF	OFF	OFF	OFF

TABLE A-3. Examples of the Address Settings

Address (Dec.)	S1-1	S1-2	S1-3	S1-4	S1-5	S1-6	S1-7	S1-8
0x01 (1)	ON	ON	ON	ON	ON	ON	ON	OFF
0x02 (2)	ON	ON	ON	ON	ON	ON	OFF	ON
0x10(16)	ON	ON	ON	OFF	ON	ON	ON	ON
0xB5(181)	OFF	ON	OFF	OFF	ON	OFF	ON	OFF

NetLink Plug-And-Play CP Setup

The **NetLink Plug-And-Play** setup allows you to forgo setting the Customer Premise box until after the management station has been installed. This means that there are NO-SETTINGS-NEEDED before the box is shipped to the end customer. The only configuration needed is to set all dip-switches to the "ON" position. This will allow the remote stand alone unit to link up with the local rack card unit. Once this is done all configuration for the local and remote unit can be done through the management station.

NOTE: When the **NetLink Plug-And-Play** is activated on the Customer Premise box, the unit will power up and default to the Receive Recover clocking mode. As the handshaking is taking place, the rack card will pass the DTE rate across the link to the remote unit. Then the units will link at that DTE/line rate. You is allowed to setup the link through the management station prior to the installation of the link with the restriction that the NetLink-mDSL rack card **MUST** be either set for Internal or External clocking. This restriction is in place because the NetLink-mDSL stand alone unit at the far end will default to the Receive Recovered clocking mode.

Model 1095 Configuration Slot

The Model 1095 Configuration Slot web page, (Figure A-1), gives you the ability to make configuration changes to the Model 1095RC and the remote CPE box. When you first enter the page, the unit is set to the onLine state and the current configuration is displayed. The following diagram shows the web page navigation required to get to this area of the system. This section provides a step by step example of how to make configuration changes. The end of this document shows the two main web pages that pertain to the 1095 mDSL modems. After each web page is a description of the MIB variables that are available from the web page.

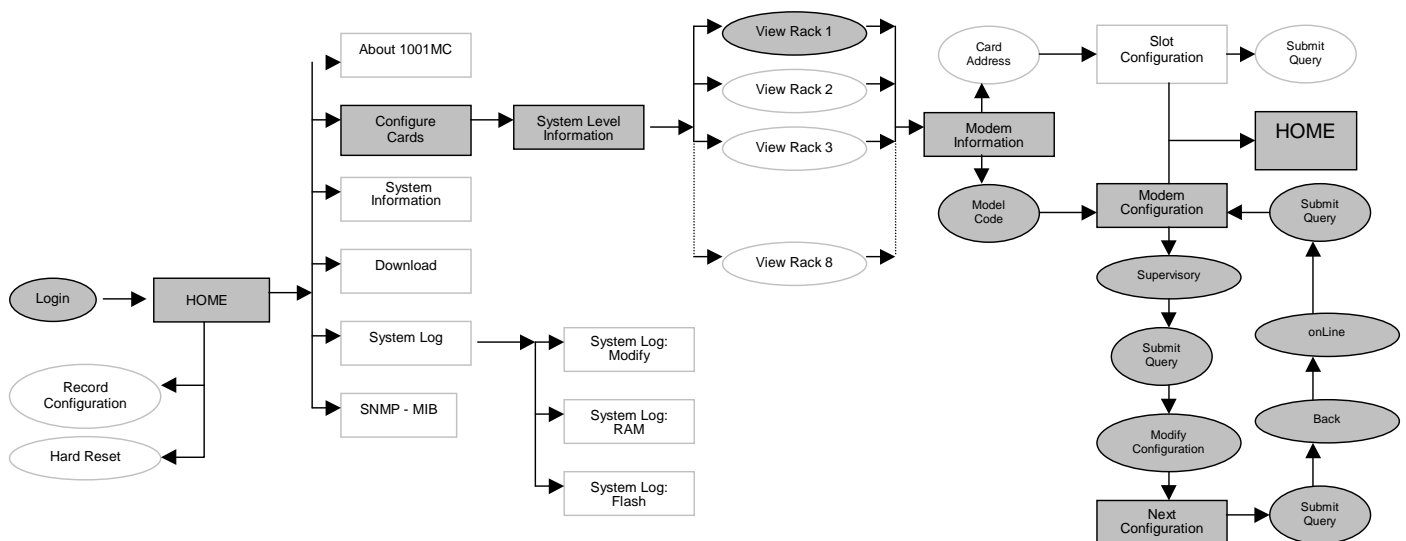

Making Configuration Changes to your NetLink Modems

Once you have reached the Modem Configuration web page, use the following steps to make configuration changes to your NetLink modems.

- 1) Change the Input Mode to "superVisoryMode". The Modify Configuration hyperlink will appear.
- 2) Select the Modify Configuration hyperlink. This hyperlink will take you to the Model 1095 Next Configuration web page.
- 3) Make your configuration changes or select the "Set Default Configuration" button.
- 4) Select the "Submit Query" button to place the changes into the 1001MC temporary memory. If you decide that you do not want your changes implemented, you can select the "Clear Changes" button.
- 5) Select the Back hyperlink to return to the Configuration Slot web page.
- 6) Change the Input Mode back to "onLine" and select the "Submit Query" button. Once the unit is set back to the onLine state, the 1095RC will start the implementation of the configuration changes. Note that the variables that you changed are now highlighted in yellow. Once the 1095RC "gets" the new information, the highlight is removed. After all of the configuration information has been obtained, the implementation will be completed by the modems.

Figure A-1: Model 1095 Configuration Slot

Model 1095 Configuration Slot 3

Line Status: startup(1)
 Processor Mode: normal(0)

SLOT CONFIGURATION PAGE

Unit must be set to superVisoryMode to make configuration changes

Input Mode:

[Refresh Current Page](#) [Modify Configuration...](#)

Configuration Status: static(1)

	Local	Remote
Model Code:	model1095RC(1)	none(0)
DTE Rate:	rate2304k(39)	rate2304k(39)
Clock Mode(Local-Remote):	internal-receiveRecover(0)	receiveRecover(2)

Model 1095 Configuration Slot (nmsSlotID): Displays the address of the NetLink - mDSL modem. The address is defined by the dip-switch setting of S1 on the rack card. The remote stand alone unit has no address specified, but uses that address of the rack card that it is connected to.

Line Status (lineStatus1095): Displays the status of the line. There are three possible values that can be displayed: startup(1), dataMode(2), or testMode(3). When the line status is dataMode(2), the units are "linked-up" and ready to send data.

Processor Mode (processorMode1095) Displays the status of the processor running on the NetLink-mDSL.. There are four values that are significant to you: normal(0), internalProcessing(1), negotiating(2), and lineDown(3). When the processor is in normal(0) mode, the NetLink - mDSL modem is monitoring itself and sending the status information to the Model 1001MC. When the processor is in the internalProcessing(1) mode, it is either busy downloading code to the internal DSP or setting the data pump. When the processor is in the negotiating(2) mode, the card was just brought "on-line" and the NetLink-mDSL is setting up the configuratin parameters within the Model 1001MC. At startup, all of the fields will be highlighted in yellow, signifying that they are NOT verified parameters. As the NetLink-mDSL sets up the parameters, the fields are changed to a white background to signify that the display matches the setting of the card.

Input Mode (mode1095) To make configuration changes to the NetLink-mDSL modems, you must first set this bit to superVisoryMode(1). When the Input Mode is set to superVisoryMode(1), the Modify Configuration hyperlink will appear on the web page next to the Refresh Current Page hyperlink. Select the Modify Configuration hyperlink. The Model 1095 Update Configuration web page will appear. This page will be discussed in more detail in the following section. After making configuration changes to

the NetLink-mDSL modems in the Model 1095 Update Configuration web page, return to this page and place the Input Mode variable back to onLine(0). This will notify the Model 1001MC that the configuration has completed and will force it to copy the new configuration into the NetLink-mDSL configuration space. If this is not done, the NetLink-mDSL will never see the configuration changes that were made.

Configuration Status

This table shows the configuration for the set of units. There is a column for both the local and remote units. If a field is highlighted in yellow, this signifies one of two possible unknowns. At start up, the Model 1001MC will display a default configuration for the card and all fields will be highlighted in yellow, notifying you that the information has not been verified. During the negotiation phase, the NetLink-mDSL modem will update the configuration in the Model 1001MC with its last set of stored parameters. As these fields are updated in the Model 1001MC, the field background will change from yellow to white, signifying that the information has been updated. After the local and remote units are linked, the units will begin updating the remote information in the table, and Line Status set to data-mode(2). If a rack card is installed in the rack without a customer premise unit connected, the remote information will be left as either none or highlighted in yellow, notifying you that the information has not been verified.

The following list explains the MIB variables that are shown in the **Configuration Status**. The MIB variable names are shown in the brackets with the local MIB variable first (local/remote).

Model Code (localModelCode/ remoteModelCode) These variables display the local and remote models codes for the units that were found in the specified address.

DTE rate (dteRate1095) This variable displays the DTE rate for the link. Because the NetLink-mDSL modems are symmetrical (same rate in both direction), there is only one MIB variable that defines the DTE rate.

Clock Mode (Local-Remote) This variable defines the clock mode for the NetLink modems. The display shows the Local clock mode (rack card) and then the remote clock mode.

Tx Data Sample Point (txdEdge1095/ remotetxdEdge1095) These variables define the sampling point that is used by the NetLink-mDSL modems to read data from the DTE. In most situations these should always be set to normal(0). In high speed applications, there are situations that would require an inverted(1) sampling point.

TM From DTE (dteTM1095/ remotedteTM1095) These MIB variables define whether you would like the modems to accept test mode requests from the DTE that is connected. In normal applications this should be set to disable(1). When the application is using rear cards or interface modules that do not have loop back ability from the DTE, such as the IM2RC/IA Ethernet rear card, this variable must be set to disable(1). In most situations, if a DTE test mode is required, it should be enable only during the time that the test is needed.

HW Test Mode (testModeInd1095/ remotetestModeInd1095) These read-only variables notify you that the specified unit has been placed into a test mode through the hardware. This could have been done either through the front panel switches or from the DTE (if the TM from DTE is enabled). When a test mode is displayed, the field will be highlighted in blue to give you quick notification.

SW Test Mode (testModeSet1095/ remotetestModeSet1095) These variables notify you that the specified unit has been placed into a test mode through the management station. The management can place a unit into a test mode within the Model 1095 Update Configuration page explained in more detail below.

Software Rev (softVersion1095/ remotesoftwareversion1095) These read-only MIB variables display the current version of code that is running in the NetLink-mDSL modems. Check the download web page to see if the Model 1001MC has a newer version of code available for downloading. Through the download web page, you can update the software that is running in the NetLink-mDSL rack card. You can also update the software in the NetLink stand alone unit through the front panel control port on the unit.

Model 1095 Next Configuration

This web page allows you to update the configuration of the NetLink-mDSL modems that are installed in the system. The configuration displayed on this page will be the active configuration that was displayed on the Model 1095 Configuration web page discussed in the previous section. After making changes to the configuration on this page, select **Back** (to Configuration Status), then select on **Line** , and finally, select **Submit Query** . This will send the new information to the Model 1001MC over the network.

NOTE: If the NetLink-mDSL modems are not connected, and changes made to the remote configuration will be lost after the units link-up. All parameters in the Local column can be changed at any time.

Following the picture of the web page below, a description of each variable is given. Note that much of the information given here is also described in the previous section. In this section more detail is given regarding making changes to the variables. The same descriptions are given for ease of use.

FIGURE A-2. 1095 Configuration

The screenshot shows a web interface for configuring a 1001MC system. On the left is a vertical navigation menu with links: [HOME](#), [About 1001MC](#), [Configure Cards](#), [System Info](#), [DownLoad](#), [System Log](#), and [SNMP](#). The main content area includes:

- Processor Mode: normal(0)
- Local Software Rev: 2.01.01
- Remote Software Rev 0.0.0
- Back... *NOTE: After making configuration pages you must set the unit back to onLine mode to implement change*

The **Next Configuration** section features a table with two columns: **Local** and **Remote**.

	Local	Remote
DTE Rate:	rate64k(3) ▼	rate64k(3)
Clock Mode(Local-Remote):	internal-receiveRecover(0) ▼	receiveRecover(2)
Tx Data Sample Point:	normal(0) ▼	normal(0) ▼
TM from DTE:	disabled(1) ▼	disabled(1) ▼
Framing Mode:	slotted(1) ▼	normal(3) ▼
Test Mode:	off(1) ▼	off(1)

Below the table is a **Submit Query** button.

Card Address (nmsSlotID) Displays the address of the selected NetLink-mDSL modem.

Line Status (lineStatus1095) This variable displays the status of the line. There are three possible values that can be displayed: startup(1), dataMode(2), or testMode(3). When the line status is dataMode(2), the units are "linked-up" and ready to send data.

Processor Mode (processorMode1095) This variable displays the status of the processor running on the NetLink-mDSL.. There are four values that are significant to you: normal(0), internalProcessing(1), negotiating(2), and lineDown(3). When the processor is in normal(0) mode, the NetLink - mDSL modem is monitoring itself and sending the status information to the Model 1001MC. When the processor is in the internalProcessing(1) mode, it is either busy downloading code to the internal DSP or setting the data pump. When the processor is in the negotiating(2) mode, the card was just brought "on-line" and the NetLink-mDSL is setting up the configuratin parameters within the Model 1001MC. At startup, all of the fields will be highlighted in yellow, signifying that they are NOT verified parameters. As the NetLink-mDSL sets up the parameters, they are changed to a white background signifying that the display matches the setting of the card.

Local Software Rev (softVersion1095) These read-only MIB variable displays the current version of code that is running in the NetLink-mDSL rack card modem. You should check the download web page to see if the Model 1001MC has a newer version of code available for downloading. Through the download web page, you can update the software that is running in the NetLink-mDSL rack card.

Remote Software Rev (remotesoftwareversion1095) These read-only MIB variable displays the current version of code that is running in the NetLink-mDSL Customer Premise modem. You can update the software in the NetLink stand alone unit through the front panel control port on the unit. For more information regarding software downloads for stand alone units please visit the Patton Electronics web site.

Next Configuration Table

This table shows the configurable MIB variables for the set of units. There is a column for both the local and remote units. In some cases a single variable applies to both the local and remote unit. In this case, a single configuration field is made available in the Local column and the Remote column is made a read-only field. After changes are made, select the "Submit Query" button at the bottom of the table and then place the Input Mode back to onLine(0) in the [Model 1095 Configuration](#) page.

The following list explains the MIB variables that are shown in the **Next Configuration Table**. The MIB variable names are shown in the brackets with the local MIB variable first (local/remote).

DTE rate (dteRate1095) This variable displays the DTE rate for the link. Because the NetLink-mDSL modems are symmetrical (same rate in both direction), there is only MIB variable that defines the DTE rate. When using the **NetLink Plug-and-Play** on your Customer Premise (remote) box, this variable can be changed at any time, even before the units are linked-up. The Customer Premise box will automatically update its' configuration to the the DTE rate that is set here.

Clock Mode (Local-Remote) This variable defines the clock mode for the NetLink modems. The display shows the Local clock mode (rack card) and then the remote clock mode as a single variable in the Local column. The Remote column displays a read only field showing the remote units clocking mode. This was done to avoid an illegal configuration of the NetLink-mDSL modems. For instance, both units **CAN NOT** be set to internal clock. The options list all possible clocking combinations.

Tx Data Sample Point (txdEdge1095/ remotetxdEdge1095) These variables define the sampling point that is used by the NetLink-mDSL modems to read data from the DTE. In most situations these should always be set to normal(0). In high speed applications, there are situations that would require an invert-

CONFIGURATION WARNING: The NetLink Plug-and-Play system is designed for a standard CO/CP application. This application requires that the NetLink-mDSL rack card is configured for either internal or external clocking mode. When the Customer Premise (remote) box is set to run in the NetLink Plug-and-Play, he will boot up by default in Receive Recover clocking mode at the DTE rate specified by the NetLink-mDSL rack card. When this clocking configuration is followed, the DTE rate can be changed on the rack card regardless of whether the Customer Premise box is connected or not.

ed(1) sampling point.

TM From DTE (dteTM1095/ remotedteTM1095) These MIB variables define whether you would like the modems to accept test mode requests from the DTE that is connected. In normal applications this should be set to disable(1). When the application is using rear cards or interface modules that do not have loop back ability from the DTE, such as the IM2RC/IA Ethernet rear card, this variable must be set to disable(1). In most situations, if a DTE test mode is required, it should be enable only during the time that the test is needed.

Test Mode (testModeSet1095/ remotetestModeSet1095) These variables allow you to place the NetLink-mDSL rack card into test modes. For more information on the test modes, please see the NetLink - mDSL Test Modes section below.

Submit Query Button After making configuration changes, select **Back** (to Configuration Status), then select **on Line** , and finally, select **Submit Query** . This will submit all the configuration information to the Model 1001MC. After this, the information is stored in volatile RAM until you place the Input Mode to onLine(0). This will tell the 1001MC to copy all of the configuration information into the NetLink-mDSL configuration space.

Clear Changes Once configuration changes have been made and you have selected the "Submit Query" button, if you decide not to implement these changes, select the "Clear Changes" button. This will set the configuration back to the settings that were there when this page was entered.

Set Default Configuration: Selecting this button will place the default configuration into the **Next Configuration Table**. You must then follow the same sequence to submit the configuration as if he had manually setup the configuration.

Appendix B - Model 1094A NetLink- HDSL SNMP

This document describes the management of a Model 1094A NetLink - HDSL modem. This document is intended to be used in addition to the DIP switch manual that you received with your unit. This document describes how to manage your Model 1094A using the Model 1001MC NetLink - NMS internal HTTP engine and a standard web browser, and the Patton Enterprise MIB that is associated with the Model 1094A.

Features

- Fully SNMP manageable local and remote units using the Patton NetLink-NMS Model 1001MC
- HTTP manageable local and remote units using the Patton NetLink-NMS Model 1001MC and a standard web browser
- Software upgrades available using the Model 1001MC download feature
- DTE speeds nx64 to 1.152 Mbps
- DSL Distances on just two wires using HDSL technology
- 2-wire operation
- Standalone (QuickConnect) and Rackmount versions available
- Internal, external, and receive recover clocking options

1094NMS Description

The NetLink HDSL Model 1094A was developed to meet the needs of Internet Service Providers (ISPs), Incumbent Local Exchange Carriers (ILECs), Inter-Exchange Carriers (IXC), and PTTs that must achieve affordable broadband transmission over the existing copper infrastructure. As a symmetric HDSL modem, the NetLink mDSL offers the same data rates in both directions over a single pair of regular telephone lines using 2B1Q modulation. Featuring replaceable DCE-DTE interface modules and rear cards, the NetLink HDSL can be configured for a huge range of interfaces including: Ethernet, Data and Voice, V.24/RS-232, V.35, RS-422/530, G.703, and X.21 applications. Line connection is made by an RJ-45 jack.

Specifically designed for use in the Patton NetLink system, when the NetLink HDSL is coupled with the Model 1001MC (NetLink-NMS) and the Patton Model 1001R14/16P rack system, the modems are fully SNMP manageable. SNMP management can be performed on both the local and remote units using a standard SNMP Network Management Station (NMS) or by using a standard web browser and the Model 1001MC's built in web server. You can view and change configuration variables, view statistical variables, and view error and warning indications.

Configuration and Management

This section describes the configuration and management of your NetLink mDSL modems using a Model 1001MC NetLink-NMS management card with built in HTTP web server. If you plan to manage your units using a standard Network Management Station (NMS) you can download the Patton Enterprise MIBs either through the SNMP web page on the Model 1001MC or visit the Patton web site.

There are two separate ways to setup your modems for communication: dip-switch controlled, and Netlink managed. The dip-switched controlled setups are not described in this manual. Please refer to the dip-switch manual that was shipped with your unit for more information on the dip-switch operation of your units or download the manual from the Patton website (www.patton.com).

NOTE: The applications described in the following sections are designed for a NetLink-HDSL rack card modem (CO configuration - Internal/External Clock) in a NetLink chassis with a Model 1001MC. At the remote end, a NetLink-HDSL stand alone unit (CP configuration - Receive Recover Clock) is connected as a Netlink Plug-And-Play CP. If your setup differs from this application, additional information may be needed to complete your setup. Please visit the Patton Electronics web site at www.Patton.com for a list of application notes and FAQs that are available for setting up your application. Or call Patton Electronics tech support at 301 975-1007 or email at support@patton.com.

Setting the Address of your NetLink-mDSL Rack Card:

The dip-switch manual that was shipped with your NetLink-mDSL unit specifies switch S1 as "Reserved". This switch is actually used to set the address of the modem in the NetLink system. Each card in the chassis is given a unique address through the setting of switch S1. Note, the stand alone units are not given an address through the setting of a dip-switch, they will use the address of the rack card that they are connected to. The Model 1001MC sends "POLL" messages along the internal bus looking for cards installed in the system. Once a card is found it is placed "on-line" and communication with the management station can begin. The Model 1001MC will start the POLLing with an address of 1 (address 0 is reserved as the Model 1001MC address) and continue up to **totalConfigSlots** (This variable is described in detail in Section 3 and can be viewed as Total System Slots Available on the HOME page).

If an address is set outside the range of this POLLing area, the Model 1001MC will never send the card a POLL command and the card will never come "on-line". As in most networking environments, if two cards are both given the same address they will both respond to the same command causing conflicts on the bus. If two cards are set to the same address an error will be displayed on the Syslog page of the Model 1001MC reading "Possible Address Conflict: Slot xx". Note that this is not the only cause for this type of error.

If all of the bits of switch S1 are set to the "ON" position, then the unit will run completely from its dip-switch configuration. This can be useful for testing circuits independently of the management system. If an address is placed on the switch, the unit will boot from its stored flash configuration and begin looking for POLL commands from the Model 1001MC.

Switch S1 allows an 8 bit address to be assigned to a link. The following rules apply to setting the address. Bit S1-8 is the least significant bit. A bit set to "ON" is considered a "0". A bit set to "OFF" is considered a "1". Patton Electronics suggests that you set your addresses starting with address 1 at the far left of your rack (farthest away from the power supplies) and increment the numbers by one as you go from left to right. Setting the addresses in this manner will make configuration easier as you start using the web page management. An example of this is shown in table B-1.

Table B-1. Starting Address Setting

1 - 2 - 3 - 4 - 5 - 6 - 7 - 8 - 9 - 10 - 11 - 12 - 13 - NMS - PS2 - PS1

The following table B-2 shows the bit setting to configure the address.

Table B-2. Bit Setting to Configure the Address

Upper (Lower) Nibble	S1-1 (S1-5)	S1-2 (S1-6)	S1-3 (S1-7)	S1-4 (S1-8)
0	ON	ON	ON	ON
1	ON	ON	ON	OFF
2	ON	ON	OFF	ON
3	ON	ON	OFF	OFF
4	ON	OFF	ON	ON
5	ON	OFF	ON	OFF
6	ON	OFF	OFF	ON
7	ON	OFF	OFF	ON
8	OFF	ON	ON	ON
9	OFF	ON	ON	OFF
A	OFF	ON	OFF	ON
B	OFF	ON	OFF	OFF
C	OFF	OFF	ON	ON
D	OFF	OFF	ON	OFF
E	OFF	OFF	OFF	ON
F	OFF	OFF	OFF	OFF

Table B-3 Examples of the Address Settings

Address (Dec.)	S1-1	S1-2	S1-3	S1-4	S1-5	S1-6	S1-7	S1-8
0x01 (1)	ON	ON	ON	ON	ON	ON	ON	OFF
0x02 (2)	ON	ON	ON	ON	ON	ON	OFF	ON
0x10(16)	ON	ON	ON	OFF	ON	ON	ON	ON
0xB5(181)	OFF	ON	OFF	OFF	ON	OFF	ON	OFF

NetLink Managed CP Setup

The local and remote units must be configured to the same DTE rate in order to link up. At initial installation, the rack and standalone will link up at 64kbps. The DTE rate on the remote unit can only be changed after the units link up.

HTTP Management

Configure Cards:

If you have not setup the IP address of your Model 1001MC NetLink-NMS card please read the "Getting Started" section of the Model 1001MC manual to do this now. If your Model 1001MC is setup, you may now begin installation of your NetLink system. The [Configure Cards](#) hyperlink on your Model 1001MC NetLink-NMS card will bring up the [MODEM INFORMATION](#) page on your web browser. This page will give you a list of the cards that are installed in your system and a quick view of any errors or warnings associated with your modems. This web page is shown below, an explanation of each field follows. Note, this information is also contained in Section 3 of the Model 1001MC manual and is shown here for ease of use. The system related variables shown on the web page are not described here.

Figure B-1. Configure Cards

MODEM INFORMATION

Card Display Type:

Max Slots Available: 13

Number of Power Supplies:

Power Supply 1	Status:available(0)
Power Supply 2	Status:available(0)

Card Address	Warnings	Errors	Local User Id	Local ModelCode	Remote User Id	Remote ModelCode	Local Circuit ID	Remote
0	1	1	Tech Test Unit	Model 1000MC	None	None	None	None
1	0	0	Local	model1094ARC(3)	Remote	model1094A(8)	<input type="text" value="Tech Bench"/>	<input type="text"/>
2	0	0	Local	model1094ARC(3)	Remote	model1094A(8)	<input type="text"/>	<input type="text"/>

Clear System Alarms (boxAction) This selection button will clear all system alarms (warnings and errors). This includes all alarms associated with specific modems. If you would like to clear alarms on a per card basis, this is available in the [Slot Configuration](#) page.

The following information describes each column of the modem table. Note that each table heading is a hyperlink to a help page that contains information about the column.

Card Address (nmsSlotID) This variable defines the address of the card. The Model 1001MC will POLL the cards using the addresses listed in the "Card Address" column. If a modem is found with the same address, it will be displayed in that row. The address of the card is setup using the dip-switches on

the card. For more information about setting the address of a card, please refer to the appropriate section above. The address is also a hyperlink to the [Slot Configuration](#) page. This page can be used to set slot specific information about the card. For more information about the [Slot Configuration](#) page please refer to the Model 1001MC manual Chapter 3.

Warnings (warningCount) This field displays the warnings that are associated with each modem installed in the system. When warnings are present, this field will be highlighted in "yellow" and the number of warnings will be listed. For more information on the cause of the warning, you should view the [System Log](#). Warnings will be highlighted in yellow in the log. The warning for the slot can be erased in the [Slot Configuration](#) page. Note, the [System Log](#) will still display the warnings even after the number is cleared. The warning count listed in the Model 1001MC column is the sum of all warnings for the system, including the individual modems.

Errors (errorCount) This field displays the errors that are associated with each modem installed in the system. When errors are present, this field will be highlighted in "red" and the number of errors will be listed. For more information on the cause of the error, you should view the [System Log](#). Errors will be highlighted in red in the log. The errors for the slot can be erased in the [Slot Configuration](#) page. Note, the [System Log](#) will still display the errors even after the number is cleared. The error count listed in the Model 1001MC column is the sum of all error s for the system, including the individual modems.

Local User Id (localUserID) User supplied string that defines the NetLink modem installed in the rack. The string is stored in non-volatile flash within the NetLink modem and is useful for hardware identification. If the address of the modem is changed, the User ID will move to the new slot. The string can be up to 10 bytes long and can be changed or reset within the [Slot Configuration](#) page.

Local Model Code (localModelCode) This column displays the model code of the NetLink modem installed at the specified address. The Model Code is also a hyperlink into the configuration page for the NetLink modem and its remote unit. The model code information is passed to the Model 1001MC after the card is placed "on-line". The Model 1001MC is auto-sensing, meaning that when a card is found or lost, the information will automatically be updated in the system. You are not required to setup the Model Code information for each slot. When a card is removed from the system, the Model Code will be erased and an error or warning will be displayed for the slot (this depends on the settings in the [Slot Configuration](#) page)

Remote User Id (remoteUserID) User supplied string that defines the Customer Premise box at the far end of the link. The string is stored in non-volatile flash within the CP unit. If the unit is moved, you ID will move to the new slot making it useful for hardware identification. The string can be up to 10 bytes long and can be changed or reset within the [Slot Configuration](#) page.

Remote Model Code (remoteModelCode) This column displays the model code of the Customer Premise NetLink modem at the far end of the link. This information is communicated from the CP box over the link to the CO Rack Card unit. The NetLink mDSL rack card will then update the Model 1001MC. For this reason this information will not be available until after the link is made between the two modems.

Local Circuit ID (localCircuitID) The circuit ID is a 40 byte string that is stored in non-volatile flash within the Model 1001MC. This string can be changed within the [Configure Cards](#) web page or from the [Slot Configuration](#) web page. After "Submitting" the string to the management system, you are required to select the "Record Current Configuration" button on the Model 1001MC button on the Model 1001MC [HOME](#) page. This will store the information into flash making it available after a re-boot or power cycle.

Remote Circuit ID (remoteCircuitID) The circuit ID is a 40 byte string that is stored in non-volatile flash within the Model 1001MC. This string can be changed from the [Configure Cards](#) web page or from the [Slot Configuration](#) web page. After "Submitting" the string to the management system, you are required to select the "Record Current Configuration" button on the Model 1001MC button on the Model 1001MC [HOME](#) page. This will store the information into flash making it available after a re-boot or power cycle.

Slot Configuration

From the Configure Cards page, the address column creates a list of hyperlinks to the Slot Configuration page associated with the specified address. The Slot Configuration page can be used to set slot specific information related to the system and how the system treats the slot in the case of errors and warning. Below is a picture of a Slot Configuration page. Following the picture is a description of each variable on the page. Note that the information contained here is also available in the Model 1001MC manual and is listed here for ease of use.

Figure B-2. Slot Configuration

The screenshot shows the 'SLOT CONFIGURATION PAGE' for Patton Electronics. On the left is a vertical '1001MC CONFIGURATION MENU' with links: HOME, About 1001MC, Configure Cards, System Info, DownLoad, System Log, and SNMP. The main content area includes:
- Card Address: 1
- Local Model Code: model1094ARC(3)
- Card Identification Information section with:
 - Local User ID:
 - Remote User ID: [Submit Query]
 - [Clear Local ID] [Clear Remote ID]
- Another Card Identification Information section with:
 - Local Circuit ID: [Submit Query] [Clear Local Circuit ID]
 - Remote Circuit ID: [Submit Query] [Clear Remote Circuit ID]
- Alarm Information section with:
 - [Clear Slot Alarms] [Hardware Reset]
 - Card Lost Indication:
 - Line Down Indication: [Submit Query]

Identification Information:

Local User Id (localUserID) User supplied string that defines the NetLink modem installed in the rack. The string is stored in non-volatile flash within the NetLink modem and is useful for hardware identification. If the address of the modem is changed, the User ID will move to the new slot. The string can be up to 10 bytes long and can be changed or reset within this page.

Remote User Id (remoteUserID) User supplied string that defines the Customer Premise box at the far end of the link. The string is stored in non-volatile flash within the CP unit. If the unit is moved, the User ID will move to the new slot making it useful for hardware identification. The string can be up to 10 bytes long and can be changed or reset within this page.

Local Circuit ID (localCircuitID) The circuit ID is a 40 byte string that is stored in non-volatile flash within the Model 1001MC.

Remote Circuit ID (remoteCircuitID) The circuit ID is a 40 byte string that is stored in non-volatile flash within the Model 1001MC.

Alarm Information:

Clear Slot Alarms (resetStatus) Selecting this push button erases the alarms (errors and warning) associated with the specified slot. Note: The errors and warning will still be listed in the [System Log](#).

Hardware Reset (resetStatus) Selecting this push button will force the associated modem to perform a hardware reset.

Card Lost Indication (cardLostIndication) This variable allows you to choose what type of indication will be made if a modem is removed from the management system. Three choices are currently available: error, warning, and none.

Line Down Indication (lineDownIndication) This variable allows you to choose what type of indication will be made if a modem reports a line down scenario. Three choices are currently available: error, warning, and none.

Modem Configuration

The **Model Code** field is a hyperlink into the Model 1094A Display Configuration page. This page, shown below, displays configuration and status information for the specified address. This page will also display a hyperlink into the Model 1094A Update Configuration web page. This can be reached when the card is placed into "supervisory mode, more information on this is available by viewing the Input Mode variable below. Following the web page below is a description of each variable.

Figure B-3. Configure Cards

Patton Electronics Home Page

Model 1094A Configuration Slot 1

Line Status: dataMode(2)
Processor Mode: normal(0)

SLOT CONFIGURATION PAGE

Unit must be set to supervisoryMode to make configuration changes

Input Mode:

[Refresh Current Page](#)

Configuration Status: static(1)

	Local	Remote
Model Code:	model1094ARC(3)	model1094A(8)
DTE Rate: <u>(Warning)</u>	rate64k(3)	rate64k(3)
Clock Mode(Local-Remote):	internal-receiveRecover(0)	receiveRecover(2)
Tx Data Sample Point:	normal(0)	normal(0)
TM from DTE:	disabled(1)	disabled(1)
HW Test Mode:	none(1)	none(1)
SW Test Mode:	off(1)	off(1)
Software Rev:	2.01.01	2.01.01

Model 1094A Configuration Slot (nmsSlotID) This variable displays the address of the NetLink - mDSL modem. The address is defined by the dip-switch setting of S1 on the rack card. The remote stand alone unit has no address specified, but uses that address of the rack card that it is connected to.

Line Status (lineStatus1095) This variable displays the status of the line. There are three possible values that can be displayed: startup(1), dataMode(2), or testMode(3). When the line status is dataMode(2), the units are "linked-up" and ready to send data.

Processor Mode (processorMode1095) This variable displays the status of the processor running on the NetLink-mDSL. There are four values that are significant to you: normal(0), internalProcessing(1), negotiating(2), and lineDown(3). When the processor is in normal(0) mode, the NetLink - mDSL modem is monitoring itself and sending the status information to the Model 1001MC. When the processor is in the internalProcessing(1) mode, it is either busy downloading code to the internal DSP or setting the data pump. When the processor is in the negotiating(2) mode, the card was just brought "on-line" and the NetLink-mDSL is setting up the configuratin parameters within the Model 1001MC. At startup, all of the fields will be highlighted in yellow, signifying that they are NOT verified parameters. As the NetLink-mDSL sets up the parameters, they are changed to a white background signifying that the display matches the setting of the card.

Input Mode (mode1095) When you plan to make configuration changes to the NetLink-mDSL modems, you must first set this bit to superVisoryMode(1). When the Input Mode is set to superVisoryMode(1), a new hyperlink names Modify Configuration will appear on the web page next to the Refresh Current Page hyperlink. Following the Modify Configuration hyperlink will display the Model 1094A Update Configuration web page. This page will be discussed in more detail in the following section. After making configuration changes to the NetLink-mDSL modems in the Model 1094A Update Configuration web page, you are required to return to this page and place the Input Mode variable back to onLine(0). This will notify the Model 1001MC that the configuration has completed and will force it to copy the new configuration into the NetLink-mDSL configuration space. If this is not done, the NetLink-mDSL will never see the configuration changes that were made.

Configuration Table

This table shows the configuration for the set of units. There is a column for both the local and remote units. If a field is highlighted in yellow, this signifies one of two possible unknowns. At start up, the Model 1001MC will display a default configuration for the card and all fields will be highlighted in yellow, notifying you that the information has not been verified. During the negotiation phase, the NetLink-mDSL modem will update the configuration in the Model 1001MC with its last set of stored parameters. As these fields are updated in the Model 1001MC, the field background will change from yellow to white, signifying that the information has been updated. After the local and remote units are linked, the units will begin updating the remote information in the table, and Line Status set to data-mode(2). If a rack card is installed in the rack without a customer premise unit connected, the remote information will be left as either none or highlighted in yellow, notifying you that the information has not been verified.

The following list explains the MIB variables that are shown in the **Configuration Table**. The MIB variable names are shown in the brackets with the local MIB variable first (local/remote).

Model Code (localModelCode/ remoteModelCode) These variables display the local and remote models codes for the units that were found in the specified address.

DTE rate (dteRate1094A) This variable displays the DTE rate for the link. Because the NetLink-mDSL modems are symmetrical (same rate in both direction), there is only one MIB variable that defines the DTE rate.

Clock Mode (Local-Remote) This variable defines the clock mode for the NetLink modems. The display shows the Local clock mode (rack card) and then the remote clock mode.

Tx Data Sample Point (txdEdge1095/ remotetxdEdge1095) These variables define the sampling point that is used by the NetLink-mDSL modems to read data from the DTE. In most situations these should always be set to normal(0). In high speed applications, there are situations that would require an inverted(1) sampling point.

TM From DTE (dteTM1095/ remotedteTM1095) These MIB variables define whether you would like the modems to accept test mode requests from the DTE that is connected. In normal applications this should be set to disable(1). When the application is using rear cards or interface modules that do not have loop back ability from the DTE, such as the IM2RC/IA Ethernet rear card, this variable must be set to disable(1). In most situations, if a DTE test mode is required, it should be enable only during the time that the test is needed.

HW Test Mode (testModeInd1095/ remotetestModeInd1095) These read-only variables notify you that the specified unit has been placed into a test mode through the hardware. This could have been done either through the front panel switches or from the DTE (if the TM from DTE is enabled). When a test mode is displayed, the field will be highlighted in blue to provide you with quick notification.

SW Test Mode (testModeSet1095/ remotetestModeSet1095) These variables notify you that the specified unit has been placed into a test mode through the management station. The management can place a unit into a test mode within the Model 1094A Update Configuration page explained in more detail below.

Software Rev (softVersion1095/ remotesoftwareversion1095) These read-only MIB variables display the current version of code that is running in the NetLink-mDSL modems. Check the download web page to see if the Model 1001MC has a newer version of code available for downloading. Through the download web page, you can update the software that is running in the NetLink-mDSL rack card. You can also update the software in the NetLink stand alone unit through the front panel control port on the unit.

Model 1094A Update Configuration

This web page allows you to update the configuration of the NetLink-mDSL modems that are installed in the system. The configuration displayed on this page will be the active configuration that was displayed on the Model 1094A Configuration web page discussed in the previous section. After making changes to the configuration on this page, you must select the "Submit Query" button at the bottom of the page. This will send the new information to the Model 1001MC over the network.

NOTE: If the NetLink-mDSL modems are not connected, and changes made to the remote configuration will be lost after the units link-up. All parameters in the Local column can be changed at any time.

Following the picture of the web page below, a description of each variable is given. Note that much of the information given here is also described in the previous section. In this section more detail is given regarding making changes to the variables. The same descriptions are given for ease of use.

Figure B-4. Configure Cards

Patton Electronics
Home Page

HOME

About 1001MC

Configure Cards

System Info

Download

System Log

SNMP

Model 1094A Configuration Slot 1

Line Status: dataMode(2)
Processor Mode: normal(0)

SLOT CONFIGURATION PAGE

Unit must be set to supervisoryMode to make configuration changes

Input Mode:

[Refresh Current Page](#)

Configuration Status: static(1)

	Local	Remote
Model Code:	model1094ARC(3)	model1094A(8)
DTE Rate: <i>(Warning)</i>	rate64k(3)	rate64k(3)
Clock Mode(Local-Remote):	internal-receiveRecover(0)	receiveRecover(2)
Tx Data Sample Point:	normal(0)	normal(0)
TM from DTE:	disabled(1)	disabled(1)
HW Test Mode:	none(1)	none(1)
SW Test Mode:	off(1)	off(1)
Software Rev:	2.01.01	2.01.01

Card Address (nmsSlotID) Displays the address of the selected NetLink-mDSL modem.

Line Status (lineStatus1095) This variable displays the status of the line. There are three possible values that can be displayed: startup(1), dataMode(2), or testMode(3). When the line status is dataMode(2), the units are "linked-up" and ready to send data.

Processor Mode (processorMode1095) This variable displays the status of the processor running on the NetLink-mDSL. There are four values that are significant to you: normal(0), internalProcessing(1), negotiating(2), and lineDown(3). When the processor is in normal(0) mode, the NetLink - mDSL modem is monitoring itself and sending the status information to the Model 1001MC. When the processor is in the internalProcessing(1) mode, it is either busy downloading code to the internal DSP or setting the data pump. When the processor is in the negotiating(2) mode, the card was just brought "on-line" and the NetLink-mDSL is setting up the configuratin parameters within the Model 1001MC. At startup, all of the fields will be highlighted in yellow, signifying that they are NOT verified parameters. As the NetLink-mDSL sets up the parameters, they are changed to a white background signifying that the display matches the setting of the card.

Local Software Rev (softVersion1095) These read-only MIB variable displays the current version of code that is running in the NetLink-mDSL rack card modem. You should check the download web page to see if the Model 1001MC has a newer version of code available for downloading. Through the download web page, you can update the software that is running in the NetLink-mDSL rack card.

Remote Software Rev (remotesoftversion1095) These read-only MIB variable displays the current version of code that is running in the NetLink-mDSL Customer Premise modem. You can update the software in the NetLink stand alone unit through the front panel control port on the unit. For more information regarding software downloads for stand alone units please visit the Patton Electronics web site.

Next Configuration Table

This table shows the configurable MIB variables for the set of units. There is a column for both the local and remote units. In some cases a single variable applies to both the local and remote unit. In this case, a single configuration field is made available in the Local column and the Remote column is made a read-only field. After changes are made, you are required to select the "Submit Query" button at the bottom of the table and then place the Input Mode back to onLine(0) in the Model 1094A Configuration page.

The following list explains the MIB variables that are shown in the **Next Configuration Table**. The MIB variable names are shown in the brackets with the local MIB variable first (local/remote).

DTE rate (dteRate1094A) This variable displays the DTE rate for the link. Because the NetLink-mDSL modems are symmetrical (same rate in both direction), there is only MIB variable that defines the DTE rate. Both units in the point-to-point link must be configured at the same DTE rate in order to link up.

Clock Mode (Local-Remote) This variable defines the clock mode for the NetLink modems. The display shows the Local clock mode (rack card) and then the remote clock mode as a single variable in the Local column. The Remote column displays a read only field showing the remote units clocking mode. This was done to avoid an illegal configuration of the NetLink-mDSL modems. For instance, both units **CAN NOT** be set to internal clock. The options list all possible clocking combinations.

Tx Data Sample Point (txdEdge1095/ remotetxdEdge1095) These variables define the sampling point that is used by the NetLink-mDSL modems to read data from the DTE. In most situations these should always be set to normal(0). In high speed applications, there are situations that would require an inverted(1) sampling point.

TM From DTE (dteTM1095/ remotedteTM1095) These MIB variables define whether you would like the modems to accept test mode requests from the DTE that is connected. In normal applications this should be set to disable(1). When the application is using rear cards or interface modules that do not have loop back ability from the DTE, such as the IM2RC/IA Ethernet rear card, this variable must be set to disable(1). In most situations, if a DTE test mode is required, it should be enable only during the time that the test is needed.

Test Mode (testModeSet1095/ remotetestModeSet1095) These variables allow you to place the NetLink-mDSL rack card into test modes. For more information on the test modes, please see the NetLink - mDSL Test Modes section below.

Submit Query Button After making configuration changes in the **Next Configuration Table**, you must select the "Submit Query" button. This will submit all the configuration information to the Model 1001MC. After this, the information is stored in volatile RAM until you place the Input Mode to onLine(0). This will tell the 1001MC to copy all of the configuration information into the NetLink-mDSL configuration space.

Clear Changes Once configuration changes have been made and you have selected the "Submit Query" button, if you decide not to implement these changes, select the "Clear Changes" button. This will set the configuration back to the settings that were there when this page was entered.

Set Default Configuration: Selecting this button will place the default configuration into the **Next Configuration Table**. You must then follow the same sequence to submit the configuration as if he had manually setup the configuration.

Appendix C - Model 1092A NetLink- iDSL SNMP

This document describes the management of a Model 1092A NetLink - iDSL modem. This document is intended to be used in addition to the manual that you received with your unit. This document describes how to manage your Model 1092A using the Model 1001MC NetLink - NMS internal HTTP/HTML web engine and a standard web browser, the Patton Enterprise MIB that is associated with the Model 1092A, can be used with your modems.

Features

- Fully SNMP manageable local and remote units using the Patton NetLink-NMS Model 1001MC
- HTTP/HTML manageable local and remote units using the Patton NetLink-NMS Model 1001MC and a standard web browser
- DTE speeds 19.2K, 32K, 50K, 64K, 128K.
- DSL Distances on just two wires using iDSL technology
- 2-wire operation
- Standalone (QuikConnect), Rackmount, and Fixed Interface (1088) versions available
- Internal, external, and receive recover clocking options

1092ANMS Description

The NetLink iDSL Model 1092A was developed to meet the needs of Internet Service Providers (ISPs), Incumbent Local Exchange Carriers (ILECs), Inter-Exchange Carriers (IXC), and PTTs that must achieve affordable broadband transmission over the existing copper infrastructure. As a symmetric DSL modem, the NetLink iDSL offers the same data rates in both directions over a single pair of regular telephone lines using 2B1Q modulation. Featuring replaceable DCE-DTE interface modules and rear cards, the NetLink iDSL can be configured for a huge range interfaces including: Ethernet, Data and Voice, V.24/RS-232, V.35, RS-422/530, G.703, and X.21 applications. Line connection is made by an RJ-45 jack.

Specifically designed for use in the Patton NetLink system, when the NetLink iDSL is coupled with the Model 1001MC (NetLink-NMS) and the Patton Model 1001R14/16P rack system, the modems are fully SNMP manageable. SNMP management can be performed on both the local and remote units using a standard SNMP Network Management Station (NMS) or by using a standard web browser and the Model 1001MC's built in web server. You can view and change configuration variables, view statistical variables, and view error and warning indications.

Configuration and Management

This section describes the configuration and management of your NetLink iDSL modems using a Model 1001MC NetLink-NMS management card with built in HTTP/HTML web server. If you plan to manage your units using a standard Network Management Station (NMS) you can download the Patton Enterprise MIBs either through the SNMP web page on the Model 1001MC or visit the Patton web site.

There are two separate ways to setup your modems for communication: dip-switch controlled, and Netlink Plug-And-Play CP. The NetLink Plug Plug-and-Play setup is described in more detail on the following page. The dip-switched controlled setups are not described in this manual. Please refer to the manual that was shipped with your unit for more information on the dip-switch operation of your units or download the manual from the Patton website (www.patton.com).

NOTE: The applications described in the following sections are designed for a NetLink-iDSL rack card modem (CO configuration - Internal/External Clock) in a NetLink chassis with a Model 1001MC. At the remote end, a NetLink-iDSL stand alone unit (CP configuration - Receive Recover Clock) is connected as a Netlink Plug-And-Play CP. If your setup differs from this application, additional information may be needed to complete your setup. Please visit the Patton Electronics web site at www.Patton.com for a list of application notes and FAQs that are available for setting up your application. Or call Patton Electronics tech support at 301 975-1007 or email at support@patton.com.

Hardware Setup of your NetLink-iDSL Rack Card:

The Model 1001MC uses the internal bus bar connection to communicate with your NetLink modems. To ensure a reliable connection between the Model 1001MC and the Model 1092A, set the rear cards on all modems to have Frame GND connected to Signal GND through a 100 Ohm resistor. For more information on making this connection, please refer to the 1092A manual that was shipped with your unit.

The manual that was shipped with your NetLink-iDSL unit specifies switch S2 as Address. This switch is used to set the address of the modem in the NetLink system. Each card in the chassis is given a unique address through the setting of switch S2. Note, the stand alone units are not given an address through the setting of a dip-switch, they will use the address of the rack card that they are connected to. The Model 1001MC sends "POLL" messages along the internal bus looking for cards installed in the system. Once a card is found it is placed "on-line" and communication with the management station can begin.

If the address of the NetLink modem is not configured or does not match the address range of the rack that it is installed in, the Model 1001MC may not recognize the card. The address range that is POLLED is determined by the configuration of the system. The system administrator must make sure that the software configuration within the Model 1001MC matches the hardware configuration of the system.

The Model MC1001MC uses the number of power supplies in the system to determine what the address range of the individual racks will be. The number of power supplies installed in each rack is entered on the Modem Information page. If the system is set for two power supplies installed, the 1001MC will automatically set the number of Slots Available (displayed on the Modem Information page) in the chassis to 13. If the system is set for a single power supply installed, the 1001MC will automatically set the number of Slots Available in the chassis to 15.

Using this information, the Model 1001MC will POLL the specified address range in each rack. Thus, in a single power supply system, the address range for Rack #1 (the rack with the 1001MC installed) will be from address 1 to address 15 (NOTE: the 1001MC is always address 0). The 1001MC will then begin POLLing Rack #2 on the daisy chain port starting from address 16. In a redundant power supply system, the address range for Rack #1 (the rack with the 1001MC installed) will be from address 1 to address 13. The 1001MC will then begin POLLing Rack #2 on the daisy chain port starting from address 14.

The daisy chained racks are setup in the same manner with 13 addresses being available in a redundant system and 15 addresses being available in single supply system. When you disable a rack the addresses are still set aside for that rack space. If a power supply is removed, the addressing will not change unless you make the change through the 1001MC web pages. This allows easy service of the power supplies.

Appendix C - 1092A NetLink - iDSL SNMP

If the address is 0 (all ON position), then the unit will run completely from its' dip-switch configuration. This can be useful for testing circuits independently of the management system. If an address is placed on the switch, the unit will boot from its stored flash configuration and begin looking for POLL commands from the Model 1001MC.

Switch S2 allows an 8 bit address to be assigned to a link. The following rules apply to setting the address. Bit S2-8 is the least significant bit. A bit set to "ON" is considered a "0". A bit set to "OFF" is considered a "1". Patton Electronics suggests that you set your addresses starting with address 1 at the far left of your rack (farthest away from the power supplies) and increment the numbers by one as you go from left to right. Setting the addresses in this manner will make configuration easier as you start using the web page management. An example of this is shown in table C-1.

Table C-1. Starting Address Setting

1 - 2 - 3 - 4 - 5 - 6 - 7 - 8 - 9 - 10 - 11 - 12 - 13 - NMS - PS2 - PS1

The following table C-2 shows the bit setting to configure the address.

TABLE C-2. Bit Setting to Configure the Address

Upper (Lower) Nibble	(S2-4)	S2-7 (S2-3)	S2-6 (S2-2)	S2-5 (S2-1)
0	ON	ON	ON	ON
1	ON	ON	ON	OFF
2	ON	ON	OFF	ON
3	ON	ON	OFF	OFF
4	ON	OFF	ON	ON
5	ON	OFF	ON	OFF
6	ON	OFF	OFF	ON
7	ON	OFF	OFF	ON
8*	OFF	ON	ON	ON
9*	OFF	ON	ON	OFF
A*	OFF	ON	OFF	ON
B*	OFF	ON	OFF	OFF
C*	OFF	OFF	ON	ON
D*	OFF	OFF	ON	OFF
E*	OFF	OFF	OFF	ON
F*	OFF	OFF	OFF	OFF

* 8 - F are *only* available for Lower Nibble.

TABLE C-3. Examples of the Address Settings

Address (Dec.)	S2-7	S2-6	S2-5	S2-4	S2-3	S2-2	S2-1
0x01 (1)	ON	ON	ON	ON	ON	ON	OFF
0x02 (2)	ON	ON	ON	ON	ON	OFF	ON
0x10(16)	ON	ON	OFF	ON	ON	ON	ON
0x35(53)	ON	OFF	OFF	ON	OFF	ON	OFF

Model 1092A Configuration Slot

The Model 1092A Configuration Slot web page, (Figure A-1), gives you the ability to make configuration changes to the Model 1092A and the remote CPE box. When you first enter the page, the unit is set to the onLine state and the current configuration is displayed. The following diagram shows the web page navigation required to get to this area of the system. This section provides a step by step example of how to make configuration changes. The end of this document shows the two main web pages that pertain to the 1092A modems. After each web page is a description of the MIB variables that are available from the web page.

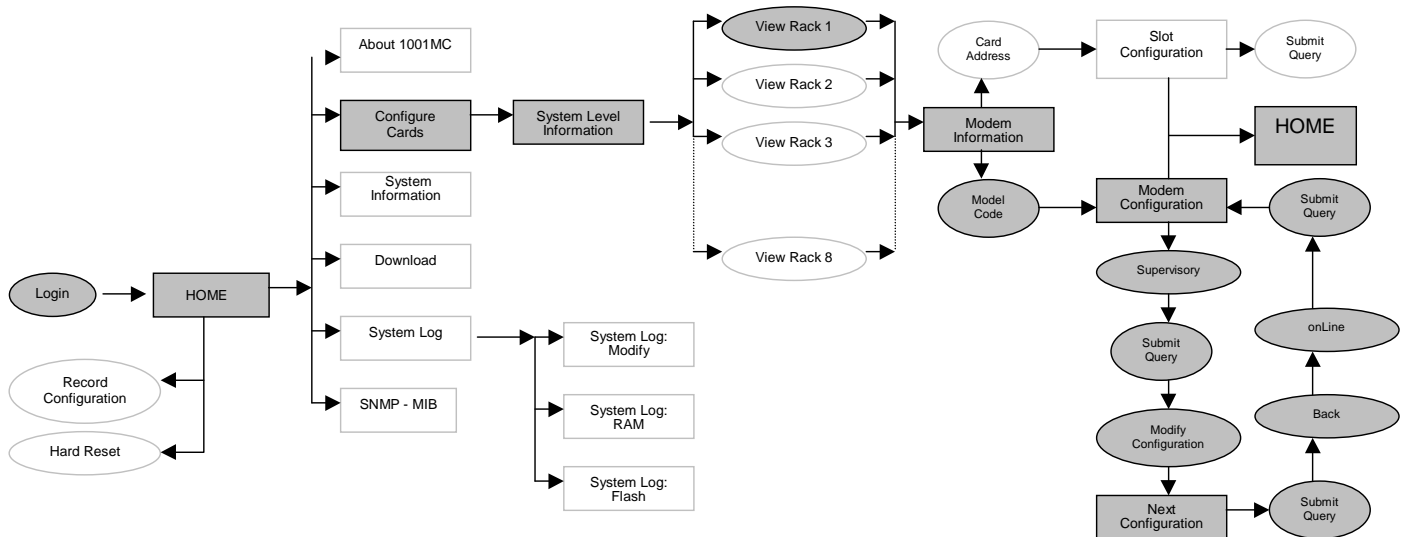
**Making Configuration Changes to your NetLink Modems**

Once you have reached the Modem Configuration web page, use the following steps to make configuration changes to your NetLink modems.

- 1) Change the Input Mode to "superVisoryMode". The Modify Configuration hyperlink will appear.
- 2) Select the Modify Configuration hyperlink. This hyperlink will take you to the Model 1092A Next Configuration web page.
- 3) Make your configuration changes or select the "Set Default Configuration" button.
- 4) Select the "Submit Query" button to place the changes into the 1001MC temporary memory. If you decide that you do not want your changes implemented, you can select the "Clear Changes" button.
- 5) Select the Back hyperlink to return to the Configuration Slot web page.
- 6) Change the Input Mode back to "onLine" and select the "Submit Query" button. Once the unit is set back to the onLine state, the 1092A will start the implementation of the configuration changes.

Note that the variables that you changed are now highlighted in yellow. Once the 1092A "gets" the new information, the highlight is removed. After all of the configuration information has been obtained, the implementation will be completed by the modems.

Model 1092A Configuration Slot (nmsSlotID): Displays the address of the NetLink - iDSL modem. The address is defined by the dip-switch setting of S1 on the rack card. The remote stand alone unit has no address specified, but uses that address of the rack card that it is connected to.

Figure C-1: Model 1092A Configuration Slot

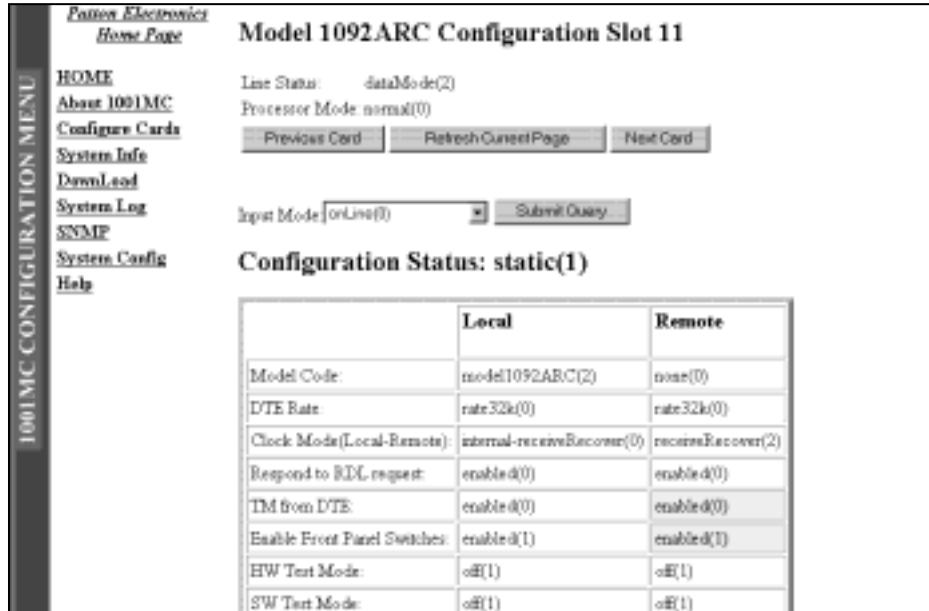

Line Status (lineStatusiDSL): Displays the status of the line. There are three possible values that can be displayed: startup(1), dataMode(2), or testMode(3). When the line status is dataMode(2), the units are "linked-up" and ready to send data.

Processor Mode (processorModeiDSL) Displays the status of the processor running on the NetLink-iDSL. There are four values that are significant to you: normal(0), internalProcessing(1), negotiating(2), and lineDown(3). When the processor is in normal(0) mode, the NetLink - iDSL modem is monitoring itself and sending the status information to the Model 1001MC. When the processor is in the internalProcessing(1) mode, it is either busy downloading code to the internal DSP or setting the data pump. When the processor is in the negotiating(2) mode, the card was just brought "on-line" and the NetLink-iDSL is setting up the configuratin parameters within the Model 1001MC. At startup, all of the fields will be highlighted in yellow, signifying that they are NOT verified parameters. As the NetLink-iDSL sets up the parameters, the fields are changed to a white background to signify that the display matches the setting of the card.

Input Mode (mode1092A) To make configuration changes to the NetLink-iDSL modems, you must first set this bit to superVisoryMode(1). When the Input Mode is set to superVisoryMode(1), the Modify Configuration hyperlink will appear on the web page next to the Refresh Current Page hyperlink. Select the Modify Configuration hyperlink. The Model 1092A Update Configuration web page will appear. This page will be discussed in more detail in the following section. After making configuration changes to the NetLink-iDSL modems in the Model 1092A Update Configuration web page, return to this page and place the Input Mode variable back to onLine(0). This will notify the Model 1001MC that the configuration has completed and will force it to copy the new configuration into the NetLink-iDSL configuration space. If this is not done, the NetLink-iDSL will never see the configuration changes that were made.

Configuration Status

This table shows the configuration for the set of units. There is a column for both the local and remote units. If a field is highlighted in yellow, this signifies one of two possible unknowns. At start up, the Model 1001MC will display a default configuration for the card and all fields will be highlighted in yellow, notifying you that the information has not been verified. During the negotiation phase, the NetLink-iDSL modem will update the configuration in the Model 1001MC with its last set of stored parameters. As these fields are updated in the Model 1001MC, the field background will change from yellow to white, signifying that the information has been updated. After the local and remote units are linked, the units will begin updating the remote information in the table, and Line Status set to datamode(2). If a rack card is installed in the rack without a customer premise unit connected, the remote information will be left as either none or highlighted in yellow, notifying you that the information has not been verified.

The following list explains the MIB variables that are shown in the **Configuration Status**. The MIB variable names are shown in the brackets with the local MIB variable first (local/remote).

Model Code (localModelCode/ remoteModelCode) These variables display the local and remote models codes for the units that were found in the specified address.

DTE rate (dteRateiDSL) This variable displays the DTE rate for the link. Because the NetLink-iDSL modems are symmetrical (same rate in both direction), there is only one MIB variable that defines the DTE rate.

Clock Mode (Local-Remote) This variable defines the clock mode for the NetLink modems. The display shows the Local clock mode (rack card) and then the remote clock mode.

TM From DTE (dteTMiDSL/ remotedteTMiDSL) These MIB variables define whether you would like the modems to accept test mode requests from the DTE that is connected. In normal applications this should be set to disable(1). When the application is using rear cards or interface modules that do not have loop back ability from the DTE, such as the IM2RC/IA Ethernet rear card, this variable must be set to disable(1). In most situations, if a DTE test mode is required, it should be enable only during the time that the test is needed.

HW Test Mode (testModeIndiDSL/ remotetestModeIndiDSL) These read-only variables notify you that the specified unit has been placed into a test mode through the hardware. This could have been done either through the front panel switches or from the DTE (if the TM from DTE is enabled). When a test mode is displayed, the field will be highlighted in blue to give you quick notification.

SW Test Mode (testModeSetiDSL/ remotetestModeSetiDSL) These variables notify you that the specified unit has been placed into a test mode through the management station. The management can place a unit into a test mode within the Model 1092A Update Configuration page explained in more detail below.

Software Rev (softVersioniDSL/ remotesoftwareversioniDSL) These read-only MIB variables display the current version of code that is running in the NetLink-iDSL modems. Check the download web page to see if the Model 1001MC has a newer version of code available for downloading. Through the download web page, you can update the software that is running in the NetLink-iDSL rack card. You can also update the software in the NetLink stand alone unit through the front panel control port on the unit.

Model 1092A Next Configuration

This web page allows you to update the configuration of the NetLink-iDSL modems that are installed in the system. The configuration displayed on this page will be the active configuration that was displayed on the Model 1092A Configuration web page discussed in the previous section. After making changes to the configuration on this page, select **Back** (to Configuration Status), then select on **Line** , and finally, select **Submit Query** . This will send the new information to the Model 1001MC over the network.

NOTE: If the NetLink-iDSL modems are not connected, and changes made to the remote configuration will be lost after the units link-up. All parameters in the Local column can be changed at any time.

Following the picture of the web page below, a description of each variable is given. Note that much of the information given here is also described in the previous section. In this section more detail is given regarding making changes to the variables. The same descriptions are given for ease of use.

FIGURE C-2. 1092A Configuration

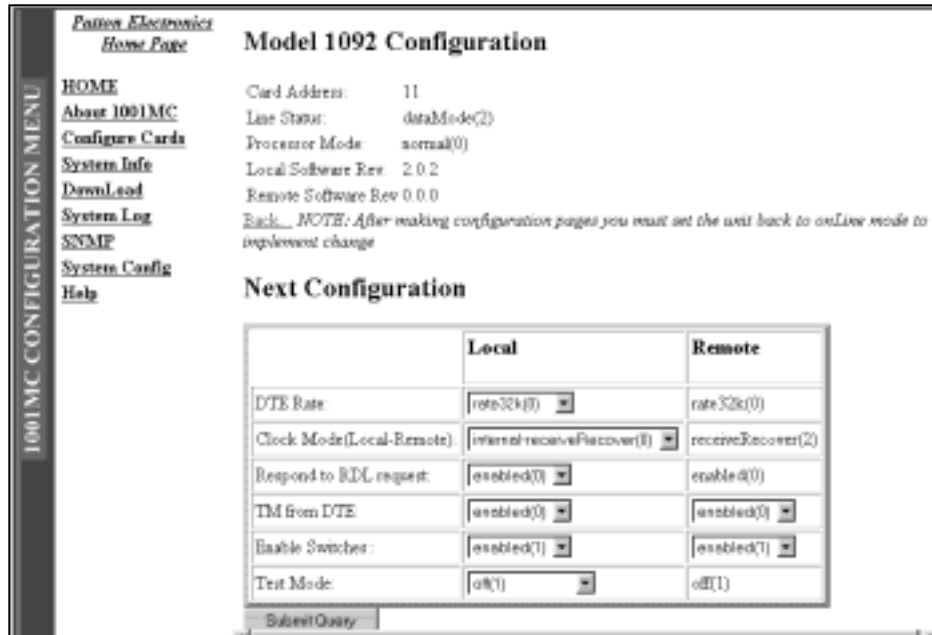

Card Address (nmsSlotID) Displays the address of the selected NetLink-iDSL modem.

Line Status (lineStatusiDSL) This variable displays the status of the line. There are three possible values that can be displayed: startup(1), dataMode(2), or testMode(3). When the line status is dataMode(2), the units are "linked-up" and ready to send data.

Processor Mode (processorModeiDSL) This variable displays the status of the processor running on the NetLink-iDSL. There are four values that are significant to you: normal(0), internalProcessing(1), negotiating(2), and lineDown(3). When the processor is in normal(0) mode, the NetLink - iDSL modem is monitoring itself and sending the status information to the Model 1001MC. When the processor is in the internalProcessing(1) mode, it is either busy downloading code to the internal DSP or setting the data pump. When the processor is in the negotiating(2) mode, the card was just brought "on-line" and the NetLink-iDSL is setting up the configuratin parameters within the Model 1001MC. At startup, all of the fields will be highlighted in yellow, signifying that they are NOT verified parameters. As the NetLink-iDSL sets up the parameters, they are changed to a white background signifying that the display matches the setting of the card.

Local Software Rev (softVersioniDSL) These read-only MIB variable displays the current version of code that is running in the NetLink-iDSL rack card modem. You should check the download web page to see if the Model 1001MC has a newer version of code available for downloading. Through the download web page, you can update the software that is running in the NetLink-iDSL rack card.

Remote Software Rev (remotesoftversioniDSL) These read-only MIB variable displays the current version of code that is running in the NetLink-iDSL Customer Premise modem. You can update the software in the NetLink stand alone unit through the front panel control port on the unit. For more information regarding software downloads for stand alone units please visit the Patton Electronics web site.

Next Configuration Table

This table shows the configurable MIB variables for the set of units. There is a column for both the local and remote units. In some cases a single variable applies to both the local and remote unit. In this case, a single configuration field is made available in the Local column and the Remote column is made a read-only field. After changes are made, select the "Submit Query" button at the bottom of the table and then place the Input Mode back to onLine(0) in the [Model 1092 Configuration](#) page.

The following list explains the MIB variables that are shown in the **Next Configuration Table**. The MIB variable names are shown in the brackets with the local MIB variable first (local/remote).

DTE rate (dteRateiDSL) This variable displays the DTE rate for the link. Because the NetLink-iDSL modems are symmetrical (same rate in both direction), there is only MIB variable that defines the DTE rate. The Customer Premise box will automatically update its' configuration to the the DTE rate that is set here.

Clock Mode (Local-Remote) This variable defines the clock mode for the NetLink modems. The display shows the Local clock mode (rack card) and then the remote clock mode as a single variable in the Local column. The Remote column displays a read only field showing the remote units clocking mode. This was done to avoid an illegal configuration of the NetLink-iDSL modems. For instance, both units **CAN NOT** be set to internal clock. The options list all possible clocking combinations.

TM From DTE (dteTMiDSL/ remotedteTMiDSL) These MIB variables define whether you would like the modems to accept test mode requests from the DTE that is connected. In normal applications this should be set to disable(1). When the application is using rear cards or interface modules that do not have loop back ability from the DTE, such as the IM2RC/IA Ethernet rear card, this variable must be set to disable(1). In most situations, if a DTE test mode is required, it should be enable only during the time that the test is needed.

Test Mode (testModeSetiDSL/ remotetestModeSetiDSL) These variables allow you to place the NetLink-iDSL rack card into test modes. For more information on the test modes, please see the NetLink - iDSL Test Modes section below.

Submit Query Button After making configuration changes, select Back (to Configuration Status), then select on Line , and finally, select Submit Query . This will submit all the configuration information to the Model 1001MC. After this, the information is stored in volatile RAM until you place the Input Mode to onLine(0). This will tell the 1001MC to copy all of the configuration information into the NetLink-iDSL configuration space.

Clear Changes Once configuration changes have been made and you have selected the "Submit Query" button, if you decide not to implement these changes, select the "Clear Changes" button. This will set the configuration back to the settings that were there when this page was entered.

Set Default Configuration: Selecting this button will place the default configuration into the **Next Configuration Table**. You must then follow the same sequence to submit the configuration as if he had manually set up the configuration.

Appendix D- Model 2701RCNetLink- E1 SNMP

This document describes the management of a Model 2701RC NetLink - E1 modem, it is intended to be used in addition to the manual that you received with your unit. This document describes how to manage your Model 2701RC using the Model 1001MC NetLink- E1- NMS internal HTTP/HTML web engine and a standard web browser, and the Patton Enterprise MIB that is associated with the Model 2701RC.

Features

- Fully SNMP manageable local unit using the Patton NetLink-NMS Model 1001MC
- HTTP/HTML manageable local unit using the Patton NetLink-NMS Model 1001MC and a standard web browser
- DTE speeds nx64 to 2.048 Mbps
- Internal, external, and receive recover clocking options
- G.703 or G.704 Framing (with or without CRC-4, CAS multiframe)
- Selectable AMI or HDB3 Line Encoding

2701RCNMS Description

The Netlink-E1 Model 2701RC is a single port E1/FE1 CSU/DSU that provides high-speed WAN connectivity in a rack card package. Connecting to the serial WAN port of a switch, router, or multiplexer, the NetLink-E1 provides E1 or FE1 access at data rates of 2.048 Mbps and n x 64 kbps. The NetLink-E1 is an excellent choice when terminating leased line services, Frame Relay backbones, internet access as well as LAN-to-LAN services.

The NetLink-E1 provides digital access to a local WAN service provider or directly between two facilities over a dedicated 4-wire circuit. Featuring replaceable DCE-DTE interface modules and rear cards, the NetLink-E1 can be configured for a wide range of interfaces including: 10BaseT Ethernet, V.24/RS-232, V.35, RS-422/530, and X.21. Line connection is made by an RJ-45 jack. A dual BNC option is available on the X.21 versions.

Specifically designed for use in the Patton NetLink system, when the NetLink-E1 is coupled with the Model 1001MC (NetLink-NMS) and the Patton Model 1001R14/16P rack system, the modems are fully SNMP manageable. SNMP management can be performed on the local unit using a standard SNMP Network Management Station (NMS) or by using a standard web browser and the Model 1001MC's built in web server. The user can view and change configuration variables, view statistical variables, and view error and warning indications.

Configuration and Management

This section describes the configuration and management of your NetLink G.703/G.704 NTUs using a Model 1001MC NetLink-NMS management card with built in HTTP/HTML web server. If you plan to manage your units using a standard Network Management Station (NMS) you can download the Patton Enterprise MIBs either through the SNMP web page on the Model 1001MC or visit the Patton web site.

There are three separate ways to setup your modems for communication: dip-switch controlled, VT-100 screens, and SNMP management. The dip-switched and VT-100 controlled setups are not described in this manual. Please refer to the manual that was shipped with your unit for more information on the dip-switch and VT-100 operation of your units or download the manual from the Patton website (www.patton.com).

Hardware Setup of your 2701RC:

The Model 1001MC uses the internal bus bar connection to communicate with your NetLink E1 modems. To ensure a reliable connection between the Model 1001MC and the Model 2701RC, set the rear cards on all modems to have Frame GND connected to Signal GND through a 100 Ohm resistor. For more information on making this connection, please refer to the 2701RC manual that was shipped with your unit.

The manual that was shipped with your NetLink-E1 unit specifies switches S3 and S4 for the card address in the NetLink System. Each card in the chassis is given a unique address through the setting of switches S3 and S4. The Model 1001MC sends "POLL" messages along the internal bus looking for cards installed in the system. Once a card is found it is placed "on-line" and communication with the management station can begin.

If the address of the NetLink E1 modem is not configured or does not match the address range of the rack that it is installed in, the Model 1001MC will not recognize the card. The address range that is POLLED is determined by the configuration of the system. The system administrator must make sure that the software configuration within the Model 1001MC matches the hardware configuration of the system.

The Model 1001MC uses the number of power supplies it detects in the system to determine what the address range of the individual racks will be. The number of power supplies installed in each rack is entered on the Modem Information page. If the system is set for two power supplies installed, the 1001MC will automatically set the number of Slots Available (displayed on the Modem Information page) in the chassis to 13. If the system is set for a single power supply installed, the 1001MC will automatically set the number of Slots Available in the chassis to 15.

Using this information, the Model 1001MC will POLL the specified address range in each rack. Thus, in a single power supply system, the address range for Rack #1 (the rack with the 1001MC installed) will be from address 1 to address 15 (NOTE: the 1001MC is always address 0).

The 1001MC will then begin POLLing Rack #2 on the daisy chain port starting from address 16. In a redundant power supply system, the address range for Rack #1 (the rack with the 1001MC installed) will be from address 1 to address 13. The 1001MC will then begin POLLing Rack #2 on the daisy chain port starting from address 14.

The daisy chained racks are setup in the same manner with 13 addresses being available in a redundant system and 15 addresses being available in single supply system. When you disable a rack the addresses are still set aside for that rack space. If a power supply is removed, the addressing will not change unless you make the change through the 1001MC web pages. This allows easy service of the power supplies.

The 2701RC s are shipped to use dipswitch configuration as default. Software configuration can be enabled through either the VT-100 screens or through the NMS. To use the NMS, S2-7 must be set to the ON position, otherwise the VT-100 port is active.

Switch S3 and S4 allow a decimal address to be assigned to a link. The following rules apply to setting the address. S3 is the LSB and S4 is the MSB. For addresses 100-120, switch S1-1 should be set to ON representing the 100 s digit. Patton Electronics suggests that you set your addresses starting with address 1 at the far left of your rack (farthest away from the power supplies) and increment the numbers by one as you go from left to right. Setting the addresses in this manner will make configuration easier as you start using the web page management. An example of this is shown in table D-1.

Table D-1. Starting Address Setting

1 - 2 - 3 - 4 - 5 - 6 - 7 - 8 - 9 - 10 - 11 - 12 - 13 - NMS - PS2 - PS1

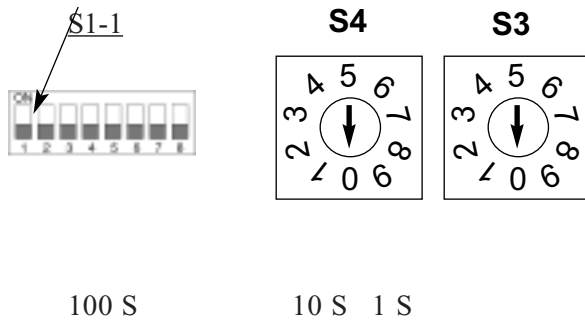

TABLE D-3. Examples of the Address Settings

Address (Dec.)	S1-1	S4	S3
(1)	OFF	0	1
(2)	OFF	0	2
(16)	OFF	1	6
(115)	ON	1	5

Model 2701RC Configuration Slot

The Model 2701RC Configuration Slot web page, (Figure D-1), gives you the ability to make configuration changes to the Model 2701RC. When you first enter the page, the unit is set to the onLine state and the current configuration is displayed. The following diagram shows the web page navigation required to get to this area of the system. This section provides a step by step example of how to make configuration changes. The end of this document shows the two main web pages that pertain to the 2701RC G.703/G.704 NTUs. After each web page is a description of the MIB variables that are available from the web page.

Making Configuration Changes to your NetLink E1 Modems

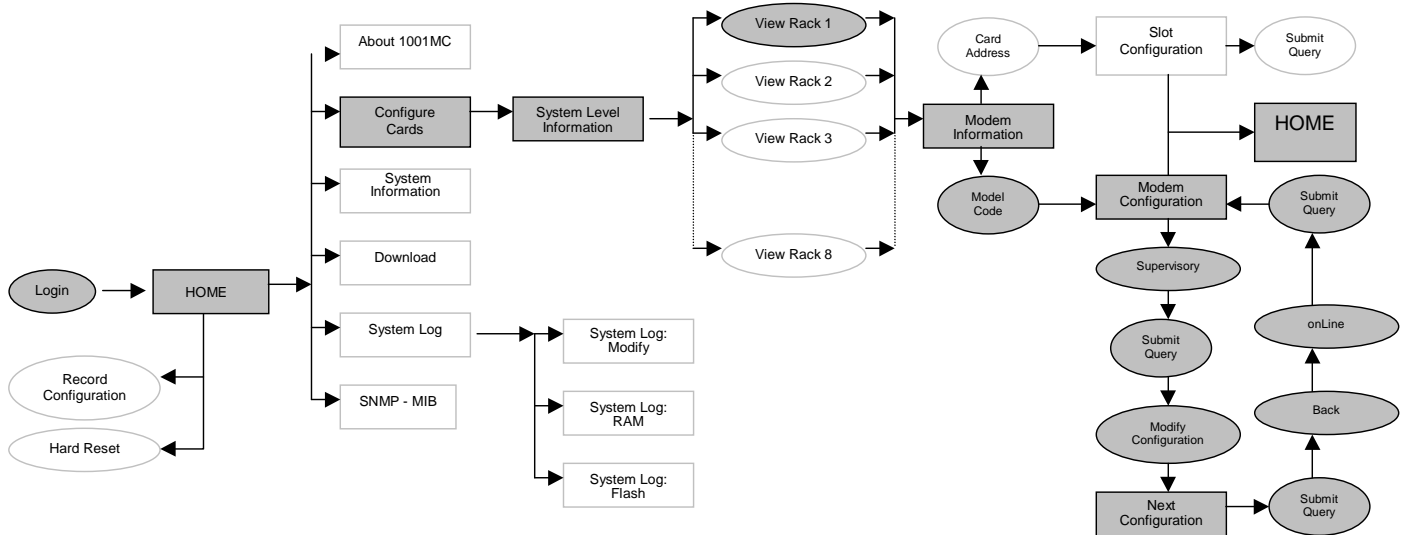

Once you have reached the Modem Configuration web page, use the following steps to make configuration changes to your NetLink E1 modems.

- 1) Change the Input Mode to "superVisoryMode". The **Modify Configuration** hyperlink will appear.
- 2) Select the **Modify Configuration** hyperlink. This hyperlink will take you to the Model 2701RC Next Configuration web page.
- 3) Make your configuration changes or select the "Set Default Configuration" button.
- 4) Select the "Submit Query" button to place the changes into the 1001MC temporary memory. If you decide that you do not want your changes implemented, you can select the "Clear Changes" button.
- 5) Select the Back hyperlink to return to the Configuration Slot web page.
- 6) Change the Input Mode back to "onLine" and select the "Submit Query" button. Once the unit is set back to the onLine state, the 2701RC will start the implementation of the configuration changes. Note that the variables that you changed are now highlighted in yellow. Once the 2701RC "gets" the new information, the highlight is removed. After all of the configuration information has been obtained, the implementation will be completed by the modems.

Figure D-1: Model 2701RC Configuration Slot

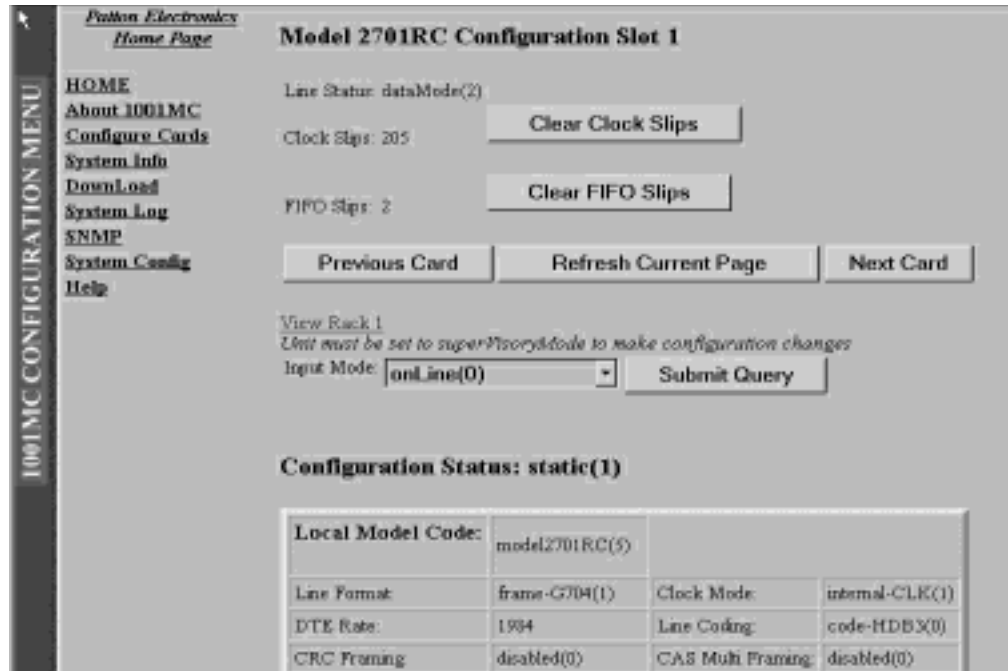

Model 2701RC Configuration Slot (nmsSlotID): Displays the address of the NetLink E1 - G.703/G.704 NTU. The address is defined by the dip-switch setting of S3 and S4 on the rack card.

Line Status (lineStatus): Displays the status of the line. There are three possible values that can be displayed: linedown(1), dataMode(2), or testMode(3). When the line status is dataMode(2), the units are "linked-up" and ready to send data.

Clock Slips(clockSlips): Displays the number of clock slips that the unit has detected. A number of clock slips may occur when the unit is linking up for the first time. If the number of clock slips continue to increase, clocking may be configured incorrectly.

FIFO Slips(fifoSlips): Displays the number of FIFO slips that the unit has detected. A number of FIFO slips may occur when the unit is linking up for the first time. If the number of FIFO slips continues to increase, the DTE rates and/or clocking may be configured incorrectly.

Input Mode (mode2701RC) To make configuration changes to the NetLink-G.703/G.704 NTUs, you must first set this field to superVisoryMode(1). When the Input Mode is set to superVisoryMode(1), the Modify Configuration hyperlink will appear on the web page next to the Refresh Current Page hyperlink. Select the Modify Configuration hyperlink. The Model 2701RC Update Configuration web page will appear. This page will be discussed in more detail in the following section. After making configuration changes to the NetLink-G.703/G.704 NTUs in the Model 2701RC Update Configuration web page, return to this page and place the **Input Mode variable back to onLine(0)**. This will notify the Model 1001MC that the configuration has completed and will force it to copy the new configuration into the NetLink E1 configuration space. If this is not done, the NetLink E1 will never see the configuration changes that were made.

Configuration Status

Configuration Status(configStatus2701RC): Displays the configuration status of the rack card. Negotiating(0) means that the 1001mc is "getting" the rack card's configuration for the first time. Static(1) means that the 1001mc is showing the updated and correct configuration for the 2701RC. ImplementingChanges(2) means that the 1001mc is updating configuration changes to the 2701RC.

Local Model Code(localModelCode): This variable displays the local model code for the unit that was found in the specified address.

Line Format(lineFormat): This option is used to set the line format to either G.703 unframed (frame-G703(0)) or framed G.704 (frame-G704(1)).

Clock Mode(clockMode2701RC): This variable defines the clock mode for the NetLink-E1 modems. Available options are network-CLK(0), internal-CLK(1), and external-CLK(2).

DTE rate(dteRate2701RC): This variable displays the DTE rate for the link. This is the Nx64 kbps data rate selected by the number of activated channels.

Line Coding(lineCoding2701RC): This variable displays the either AMI or HDB3 line coding.

CRC-4 framing(crc): This displays if CRC-4 framing is enabled or disabled.

CAS multiframe(casMF): This displays if CAS multiframe is enabled or disabled.

Line build out(lineBuildOut): This displays the selected line build out: either 75 ohm or 120 ohm.

Clock Timing(txClock): This displays whether the serial transmit data coming from the DTE is clocked in using the DCE provided transmit clock or DTE provided external clock.

Hardware test mode(testModeSetInd): This displays any test mode invoked from the toggle switches and DTE test mode lines. This option will be highlighted in blue if the unit is in test mode.

Software test mode(testModeSet2701RC): This displays any test mode invoked through the nms. See next configuration for information about invoking test modes through the nms. This option will be highlighted in blue if the unit is in test mode.

Loop enable(v54Loop): This displays if the unit will respond to a V.54 loop up command (enabled) or if the unit will ignore a V.54 loop up command (disabled).

Front Panel Switches(frntSwitch): This displays if the front panel toggle switches used for loopbacks and pattern generators are enabled or disabled.

Pattern Select(patternSelect): This displays the pattern (511, 2047, QRSS) that is used when the pattern generator and detector are turned on.

In Band Loop(inBandLoop): This displays whether the unit will respond to a CSU loop up command (enabled). If this option is disabled, the unit will ignore a CSU loop up command.

Loop Timeout(loopTo): This displays the amount of time that the unit responding to a Remote Loop command will remain in test mode when the RL test mode is invoked. If the unit is not taken out of test mode by the menu within this time period, the unit will automatically time out and return to normal data mode. The timeout does not apply for loops selected via the front panel switches.

RDL type(rdIType): This displays the selected remote loopback type that will be used when initiating a remote loopback.

Config Type(configType): This displays if the 2701RC is using the dip switch control or software control for its configuration.

Test mode from DTE(testModeDTE): This displays if the 2701RC responds to the LL and RDL signals coming from the DTE.

Software version(softVersion2701RC): This displays the software version of code in the 2701RC.

Model 2701RC Next Configuration

This web page allows you to update the configuration of the NetLink-G.703/G.704 NTUs that are installed in the system. The configuration displayed on this page will be the active configuration that was displayed on the Model 2701RC Configuration web page discussed in the previous section. After making changes to the configuration on this page, select **Back** (to Configuration Status), then select **on Line** , and finally, select **Submit Query** . This will send the new information to the Model 1001MC over the network.

A description of each variable is given, following the picture of the web page below. Note that much of the information given here is also described in the previous section. In this section more detail is given regarding making changes to the variables. The same descriptions are given for ease of use.

FIGURE D-2. 2701RC Configuration

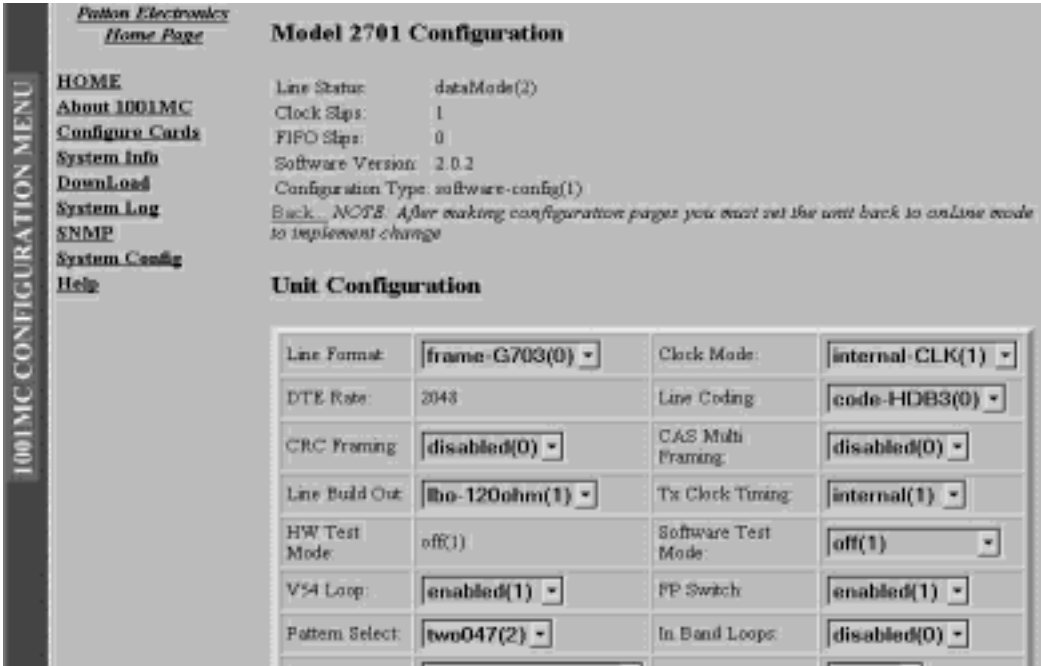

Line Status (lineStatus2701RC) This variable displays the status of the line. There are three possible values that can be displayed: startup(1), dataMode(2), or testMode(3). When the line status is dataMode(2), the units are "linked-up" and ready to send data.

Clock Slips(clockSlips): This read-only variable displays the number of clock slips that the unit is getting. A number of clock slips may occur when the unit is linking up for the first time. If the number of clock slips continue to increase, clocking may be configured incorrectly.

FIFO Slips(fifoSlips): This read-only variable displays the number of FIFO slips that the unit is getting. A number of FIFO slips may occur when the unit is linking up for the first time. If the number of FIFO slips continues to increase, the DTE rates and/or clocking may be configured incorrectly.

Config Type(configType): This displays if the 2701RC is using the dip switch control or software control for its configuration.

Software Rev (softVersion2701RC) This read-only MIB variable displays the current version of code that is running in the NetLink-E1 rack card modem.

Next Configuration Table

This table shows the configurable MIB variables for the local 2701RC. After changes are made, select the "Submit Query" button at the bottom of the table and then place the Input Mode back to onLine(0) in the [Model 2701RC Configuration](#) page.

The following list explains the MIB variables that are shown in the **Next Configuration Table**. The local MIB variable names are shown in the brackets.

Line Format(lineFormat): This option is used to set the line format to either G.703 unframed: frame-G703(0) or framed G.704: frame-G704(1).

Individual channel enabling(dsoEnableCh1 dsoEnableCh31): When line format is set to frame-G704(1), individual channels can be either enabled(1) or disabled(0). These options cannot be accessed if line format is set to frame-G703(0). Note: Timeslot 0 (Channel 1) is reserved for signaling when G.704 is enabled therefore, this channel cannot be accessed. Also, if CAS multiframing is enabled, Channel 17 cannot be accessed because it is used for signaling with CAS is enabled.

Clock Mode(clockMode2701RC): This variable defines the clock mode for the NetLink-E1 modems. Available options are network-CLK(0), internal-CLK(1), and external-CLK(2).

DTE rate(dteRate2701RC): This read-only variable displays the DTE rate for the link. This is the Nx64 kbps data rate selected by the number of activated channels.

Line Coding(lineCoding2701RC): This variable is used to select the G.703 line coding. Available options are AMI or HDB3: code-HDB3(0) or code-AMI(1).

CRC-4 framing(crc): This variable is used to enable(1) or disable(0) CRC-4 framing. Note that this setting should be the same as the G.703/G.704 network.

CAS multiframe(casMF): This variable is used to enable(1) or disable(0) CAS multiframing. Note that this setting should be the same as the G.703/G.704 network.

Line build out(lineBuildOut): This is used to select the line build out of either 75 ohm or 120 ohm: lbo-75ohm(0) or lbo-120ohm(1).

Clock Timing(txClock): This selects whether the serial transmit data coming from the DTE is clocked in using the DCE provided transmit clock or DTE provided external clock: internal(1) or external(0).

Hardware test mode(testModeSetInd): This read-only variable displays any test mode invoked from the toggle switches and DTE test mode lines. If the unit is in a test mode, this option will be highlighted in blue.

Software test mode(testModeSet2701RC): This is used to invoke test modes through the nms. Available options are off(0), pattern generator turned on - pat(1), pattern generator turned on with error insertion of once per second - pate(2), local loopback - lal(4), local loopback with pattern generator - lalWithpat(5), local loopback with pattern generator with errors - lalWithpate(6), remote digital loopback - rdl(7), remote digital loopback with pattern generator - rdlWithpat(8), remote digital loopback with patter generator with errors - rdlWithpate(9).

Loop enable(v54Loop): This selects if the unit will respond to a V.54 loop up command - enabled(1) or if the unit will ignore a V.54 loop up command - disabled(0).

Front Panel Switches(frntSwitch): This selects if the front panel toggle switches used for loopbacks and pattern generators are enabled(1) or disabled(0).

Pattern Select(patternSelect): This selects the pattern (511, 2047, QRSS) that is used when the pattern generator and detector are turned on. Available options are: qrss(0), five11(1), or two047(2).

In Band Loop(inBandLoop): This selects whether the unit will respond to a CSU loop up command - enabled(1). If this option is disabled(0), the unit will ignore a CSU loop up command.

Loop Timeout(loopTo): This selects the amount of time that the unit will remain in test mode when the remote test mode is invoked. If the responding unit is not taken out of test mode within this time period, the unit will automatically time out and return to normal data mode.

RDL type(rdlType): This displays the selected remote loopback type that will be used when initiating a remote loopback. Available options are: csu(1) or v54(2).

Config Type(configType): This selects if the 2701RC is using the dip switch control or software control for its configuration. Available options are switch-config(0) or software-config(1).

Test mode from DTE(testModeDTE): This selects if the 2701RC responds to the LL and RDL signals coming from the DTE - enabled(1).