

USER MANUAL

MODEL 1050 AC Powered, Asynchronous Short Range Modem



PA **PATTON**
IE **Electronics Co.**



*An ISO-9001
Certified Company*

Part #07M1050-B
Doc. #058031B
Revised 7/30/97

SALES OFFICE
(301) 975-1000
TECHNICAL SUPPORT
(301) 975-1007
<http://www.patton.com>

1.0 WARRANTY INFORMATION

Patton Electronics warrants all Model 1050 components to be free from defects, and will—at our option—repair or replace the product should it fail within one year from the first date of shipment.

This warranty is limited to defects in workmanship or materials, and does not cover customer damage, abuse or unauthorized modification. If this product fails or does not perform as warranted, your sole recourse shall be repair or replacement as described above. Under no condition shall **Patton Electronics** be liable for any damages incurred by the use of this product. These damages include, but are not limited to, the following: lost profits, lost savings and incidental or consequential damages arising from the use of or inability to use this product. **Patton Electronics** specifically disclaims all other warranties, expressed or implied, and the installation or use of this product shall be deemed an acceptance of these terms by the user.

1.1 RADIO AND TV INTERFERENCE

The Model 1050 generates and uses radio frequency energy, and if not installed and used properly—that is, in strict accordance with the manufacturer's instructions—may cause interference to radio and television reception. The Model 1050 has been tested and found to comply with the limits for a Class A computing device in accordance with the specifications in Subpart J of Part 15 of FCC rules, which are designed to provide reasonable protection from such interference in a commercial installation. However, there is no guarantee that interference will not occur in a particular installation. If the Model 1050 does cause interference to radio or television reception, which can be determined by disconnecting the RS-232 interface, the user is encouraged to try to correct the interference by one or more of the following measures: moving the computing equipment away from the receiver, re-orienting the receiving antenna, and/or plugging the receiving equipment into a different AC outlet (such that the computing equipment and receiver are on different branches).

1.2 CE NOTICE

The CE symbol on your Patton Electronics equipment indicates that it is in compliance with the Electromagnetic Compatibility (EMC) directive and the Low Voltage Directive (LVD) of the Union European (EU). A Certificate of Compliance is available by contacting Patton Technical Support.

1.3 SERVICE

All warranty and non-warranty repairs must be returned freight prepaid and insured to Patton Electronics. All returns must have a Return Materials Authorization number on the outside of the shipping container. This number may be obtained from Patton Electronics Technical Service at **(301) 975-1007**; <http://www.patton.com>; or, support@patton.com.

NOTE: Packages received without an RMA number will not be accepted.

Patton Electronics' technical staff is also available to answer any questions that might arise concerning the installation or use of your Model 1050. Technical Service hours: **8AM to 5PM EST, Monday through Friday.**

2.0 GENERAL INFORMATION

Thank you for your purchase of this Patton Electronics product. This product has been thoroughly inspected and tested and is warranted for One Year parts and labor. If any questions or problems arise during installation or use of this product, please do not hesitate to contact Patton Electronics Technical Support at (301) 975-1007.

2.1 FEATURES

- Asynchronous RS-232 Operation
- Data Rates to 38,400 bps
- Distances up to 7 miles (11.2 km)
- Point-to-Point or Multipoint Operation
- Optical Isolation
- Loopback Tests
- Tri-State LED Indicators
- DCE/DTE switch selectable
- Carrier Selectable for “Constantly On” or “Controlled by RTS”
- Both RJ-11 and Terminal Block Line Connectors
- Ultra-Compact Enclosure
- Externally Powered

2.2 DESCRIPTION

The Patton Model 1050 AC Powered Asynchronous Short Range Modem is to our AC powered short haul line what the Model 1000 is to our interface powered line—a basic short haul at a great price! And the Model 1050 has the key features you need: optical isolation, a local loopback test mode, LED indicators and a DCE/DTE switch. The Model 1050 supports asynchronous RS-232 data rates to 38.4 Kbps. Distances of 7 miles (11.2 km) (@ 1200 bps) are attainable over two 24 AWG (.5mm) twisted pair.

Housed in an ultra-compact metal enclosure, the Model 1050 offers a choice of line connections: both external RJ-11 jack and internal terminal block are provided. On the RS-232 side, a female DB-25 is standard. The Model 1050 is designed for point-to-point or multipoint applications, and is also compatible with the Patton 1060 and 1226 short hauls.

3.0 CONFIGURATION

The Model 1050 may be configured for a wide variety of asynchronous RS-232 applications. This section will tell you how to access and set the internal DCE/DTE switch and the internal carrier control strap. **WAIT.** Before attempting to re-configure the Model 1050, check the Default Configuration Table (below) to see if the factory settings are correct for your application.

DEFAULT 1050 CONFIGURATION TABLE		
Switch (Strap)	Factory Setting	Result
DTE/DCE Switch	DCE	Model 1050 is set to connect to DTE device (PC, Terminal, etc.)
Carrier Control Strap	Pegs 1 & 2	Carrier is “Controlled by RTS”

3.1 ACCESSING THE MODEL 1050 PC BOARD (see Note 1)

To access the internal PC board, simply remove the two screws at the rear of the unit and slide the PC board and rear panel out of the case. Figure 1 (below) shows the location of the DCE/DTE switch and the RTS strap on the PC board.

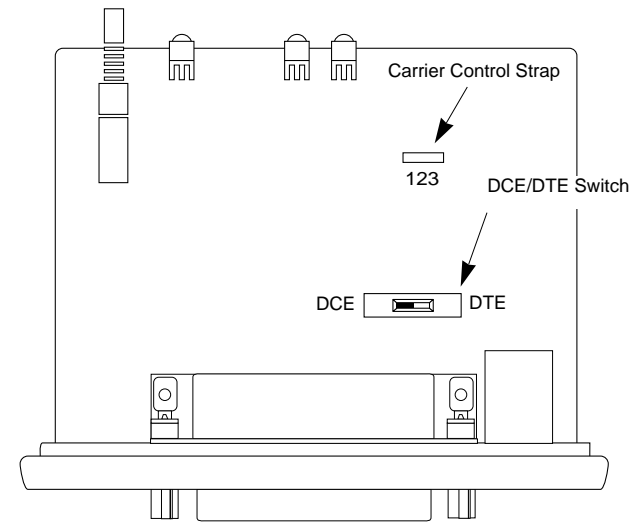

Figure 1. Switch/Strap locations on Model 1050 PC board.

4.0 INSTALLATION

3.2 SETTING THE DCE/DTE SWITCH

Correct setting of the DCE/DTE switch eliminates the need for RS-232 crossover cables. If the RS-232 device you are connecting to the Model 1050 is a PC, terminal or host, or is wired like one, set the DCE/DTE switch to "DCE". If the RS-232 device you are connecting to the Model 1050 is a modem or multiplexer, or is wired like one, set the DCE/DTE switch to "DTE".

3.3 SETTING THE CARRIER CONTROL STRAP (see Note 2)

The setting of the carrier control strap determines whether carrier is "constantly on" or "controlled by RTS". For "controlled by RTS" position the strap on pegs 1 & 2. For "constantly on" position the strap on pegs 2 & 3. Figure 2 (below) shows the two possible settings of the carrier control strap.

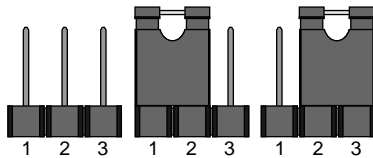

Figure 2 Model 1050 strap settings

NOTE 1: If you are connecting twisted pair to the Model 1050 using the internal **terminal blocks**, make the twisted pair connection before re-inserting the PC board into the case. See Section 4.1.1 for details on twisted pair connection.

NOTE 2: If you are using the Model 1050 in a **multipoint** application, consult Section 4.2 for proper Master and Slave carrier control settings.

The Model 1050 is easy to install. After configuring the unit properly, you will need to connect the two twisted pairs and the RS-232 cable. Figure 2 (below) shows the rear panel location of the RJ-11 jack and strain relief grommet (line connections), as well as the female DB-25 (RS-232 connection).

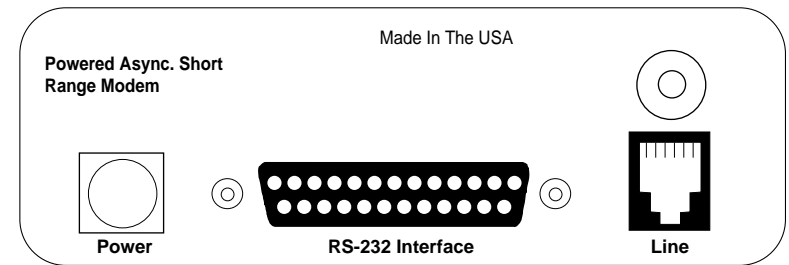

Figure 3. Rear view of 1050 showing interface connectors

4.1 TWISTED PAIR WIRING OVERVIEW

These short range modems are designed to work in *pairs*. You will need one at each end of a 4-wire twisted pair circuit. The pairs must be "dry" (unconditioned) metallic wire, 19 - 26 AWG. The smaller gauges limit distance somewhat compared with larger gauges. When you have completed wiring for your data circuit, the pin connections should be as shown below:

XMT +	-----	RCV+	} One Pair
XMT -	-----	RCV -	
G	----- To Shield (Optional)	G	
RCV -	-----	XMT -	} One Pair
RCV +	-----	XMT +	

4.1.1 TWISTED PAIR CONNECTION USING TERMINAL BLOCKS

The Model 1050 terminal block is located on the PC board inside the unit. To access the PC board, remove the two screws on the back panel and slide the PC board out of the case. Connect the bare twisted pair wires by first inserting them through the grommet on the back panel, then stripping the ends and connecting the individual leads to the terminal block. Be sure the end-to-end connections follow the diagram above.

4.1.2 TWISTED PAIR CONNECTION USING RJ-11

If your two-pair cable is terminated in an RJ-11 plug, you may use the RJ-11 jack in the back of the Model 1050 to make the connection. The RJ-11 jack on a Model 1050 series Short Range Modem is prewired for a standard TELCO wiring environment. To be sure you have the right wiring, use the diagram below as a guide.

<u>RJ-11</u>	<u>SIGNAL</u>
1 -----	GND†
2 -----	RCV-
3 -----	XMT+
4 -----	XMT-
5 -----	RCV+
6 -----	GND†

For proper signal crossing between two Model 1050s using RJ-11 connectors, pin-out the twisted pair cable according to the diagram below.

<u>RJ-11 Cable (4-Wire)</u>			
<u>SIGNAL</u>	<u>PIN#</u>	<u>PIN#</u>	<u>SIGNAL</u>
GND†	1-----	6	GND†
RCV-	2-----	4	XMT-
XMT+	3-----	5	RCV+
XMT-	4-----	2	RCV-
RCV+	5-----	3	XMT+
GND†	6-----	1	GND†

†Connection to ground is optional

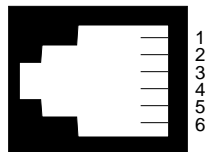

4.2 WIRING FOR MULTIPOINT CIRCUITS

The Model 1050 supports multi-point applications using either a star or daisy chain topology. Both topologies require special wiring, as well as specific carrier control strap settings for master and slave units.

4.2.1 DAISY CHAIN TOPOLOGY

Using a daisy chain topology, you may connect as many as 10 Model 1050s together in a master/slave arrangement. Maximum distance between the units will vary based upon the number of drops, data rate, wire gauge, etc. Call Patton Technical Support for specific distance estimates.

Figure 3 (below) shows how to wire the two-pair cables properly for a Model 1050 daisy chain topology. Note that the ground connection is not needed.

<u>HOST</u>	<u>FIRST SLAVE</u>	<u>OTHER SLAVE(S)</u>
XMT+-----	RCV+-----	RCV+
XMT-----	RCV-----	RCV-
RCV+-----	XMT+-----	XMT+
RCV-----	XMT-----	XMT-

Figure 3. Model 1060 daisy chain wiring

In a multipoint topology, you must configure the master Model 1050's carrier control strap differently than those of the slave Model 1050(s). Here are the proper carrier control strap settings for a daisy chain topology:

<u>Function</u>	<u>Carrier Control Strap Setting</u>
Master	Carrier "Constantly ON" (pegs 2 & 3)
Slave(s)	Carrier "Controlled by RTS" (pegs 1 & 2)

4.2.2 STAR TOPOLOGY

Using a star topology, you may connect several Model 1050s together in a master/slave arrangement. Maximum distance between the units will vary based upon the number of drops, data rate, wire gauge, etc. Call Patton Technical Support for specific distance estimates.

Figure 4 (below) shows how to wire the two-pair cables properly for a Model 1050 star topology. Note that the ground connection is not needed.

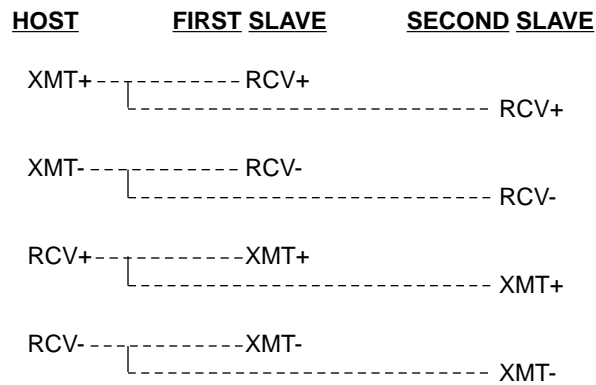

Figure 4. Model 1060 star wiring

In a multipoint topology, you must configure the master Model 1050's carrier control strap differently than those of the slave Model 1050(s). Here are the proper carrier control strap settings for a star topology:

<u>Function</u>	<u>Carrier Control Strap Setting</u>
Master	Carrier "Constantly ON" (pegs 2 & 3)
Slave(s)	Carrier "Controlled by RTS" (pegs 1 & 2)

4.3 RS-232 CONNECTION

To connect the Model 1050 to a piece of data terminal or data communications hardware, use a *straight through* RS-232 cable. Plug the cable directly into the DB-25 port on the rear of the Model 1050. The DCE/DTE switches eliminate the need for a crossover cable.

Once you have configured each Model 1050 properly and connected it, simply plug in the AC power adapter to get it running; there is no power switch on the Model 1050. You can monitor the operation of the Model 1050 using the front panel LED indicators and built-in loopback test modes.

5.1 LED INDICATORS

The Model 1050 incorporates three front panel LEDs that show the status of the modem:

1. The **loopback test** LED glows when the loopback test switch has been depressed and is in a test mode.
2. The tri-state **TD** and **RD** indicators blink red and green with data activity. Solid red indicates a low RS-232 logic level. Note: RS-232 devices idle in a low state, so the LED will glow red if the connections are correct and the RS-232 device is in an idle state.

5.2 LOOPBACK TEST MODES

Select the test modes by depressing the "Loopback Test" switch. When in loopback mode, the "Loopback Test" LED will glow red. Two tests are possible using this switch: Local Analog Loop (LAL), and Remote Analog Loop (RAL).

5.2.1 LOCAL ANALOG LOOP

The first test mode is Local Analog Loop (V.54 Loop 3). Any data sent to the local Model 1050 in this mode will be echoed (returned) back to the user device. For example, characters typed on the keyboard of a terminal will appear on the terminal screen (see Figure 3 on the following page).

(continued)

PATTON MODEL 1050 SPECIFICATIONS

5.2.2 REMOTE ANALOG LOOP

The second test mode is Remote Analog Loop. To enter this mode, set one of the Model 1050s (local) in test mode by depressing the "Loopback Test" switch. Any characters sent from the remote 1050 will be returned to it (see Figure 5). If no characters are echoed back, check the wiring between the two Model 1050s. Be sure to wire the units according to the instructions in Section 4.0 Installation.

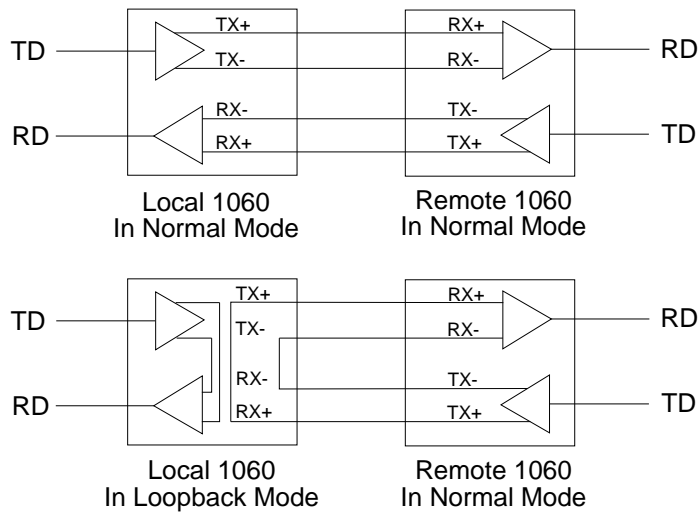

Figure 5. Loopback Test Modes

- Transmission Format:** Asynchronous
- Transmission Line:** 19 to 26 AWG twisted pair
- Range:** 7 miles on 24 AWG twisted pair @ 1200 bps
- Serial Interface:** EIA RS-232 (CCITT V.24), DB-25 female
- Twisted Pair Interface:** Terminal blocks, RJ-11 jack
- Data Rates:** 0 - 38,400 bps
- Applications:** Point-to-point, Multipoint
- Indicators:** Tri-state for transmit data, receive data, and test
- Diagnostics:** Local Analog Loopback (LAL), Remote Analog Loopback (RAL)
- Optical Isolation:** 2500V RMS (minimum)
- Power Supply:** Wall mount, 9-12VAC, 200ma
- Temperature Range:** 0-60°C (32-140°F)
- Altitude:** 0-15,000 feet
- Humidity:** 5 to 95% noncondensing
- Dimensions:** 1.58"H x 4.16"W x 3.75"D
- Weight:** 13.2 oz. (without transformer)

APPENDIX B

PATTON MODEL 1050 CABLE RECOMMENDATIONS

All Patton Electronics Company Short Range Modems are tested to the distances published in our Catalogs and Specification Sheets on twisted-pair cable with the following characteristics:

<u>Wire Gauge</u>	<u>Capacitance</u>	<u>Resistance</u>
19 AWG(.9mm)	83nF/mi or 15.72 pF/ft.	.0163Ω/ft.
22 AWG(.6mm)	83nF/mi or 15.72 pF/ft.	.0326Ω/ft.
24 AWG(.5mm)	83nF/mi or 15.72 pF/ft.	.05165Ω/ft.
26 AWG(.4mm)	83nF/mi or 15.72 pF/ft.	.08235Ω/ft.

We fully expect that the Short Range Modems will operate on lines with specifications different from those tested, but to reduce the potential difficulties in the field, one should ensure that the cable being used has similar or better characteristics (lower capacitance or lower resistance).

Wire with capacitance of 20pF/ft. or less is suitable for all our Short Range Modems however, distances may vary from those published in our catalog. Resistance will also affect distance but not functionality. Wire should be 26 AWG (.4mm) (or larger (smaller AWG#)).

Patton products are designed to withstand normal environmental noise and conditions however, other environmental factors too numerous to discuss in this format may affect proper operation of the SRM's.

Selection of the proper SRM for an application is critical to maintaining Customer Satisfaction and should be taken seriously. Certain models are better suited for particular applications and environments than others.

APPENDIX C

PATTON MODEL 1050 INTERFACE PIN ASSIGNMENT

**RS-232 FEMALE, D-SUB 25 CONNECTOR
(DCE ORIENTATION)**

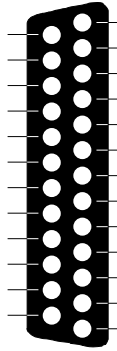
DIRECTION	STANDARD RS-232C/V.24 "DCE" SETTING	DIRECTION
		<p>To 1050</p> <p>From 1050</p> <p>To 1050</p> <p>From 1050</p> <p>From 1050</p> <p>From 1050</p> <p>From 1050</p>

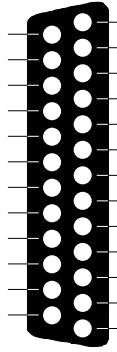
DIRECTION	STANDARD RS-232C/V.24 "DTE" SETTING	DIRECTION
From 1050		<p>From 1050</p> <p>To 1050</p> <p>From 1050</p> <p>To 1050</p>

APPENDIX D

PATTON MODEL 1090 BLOCK DIAGRAM

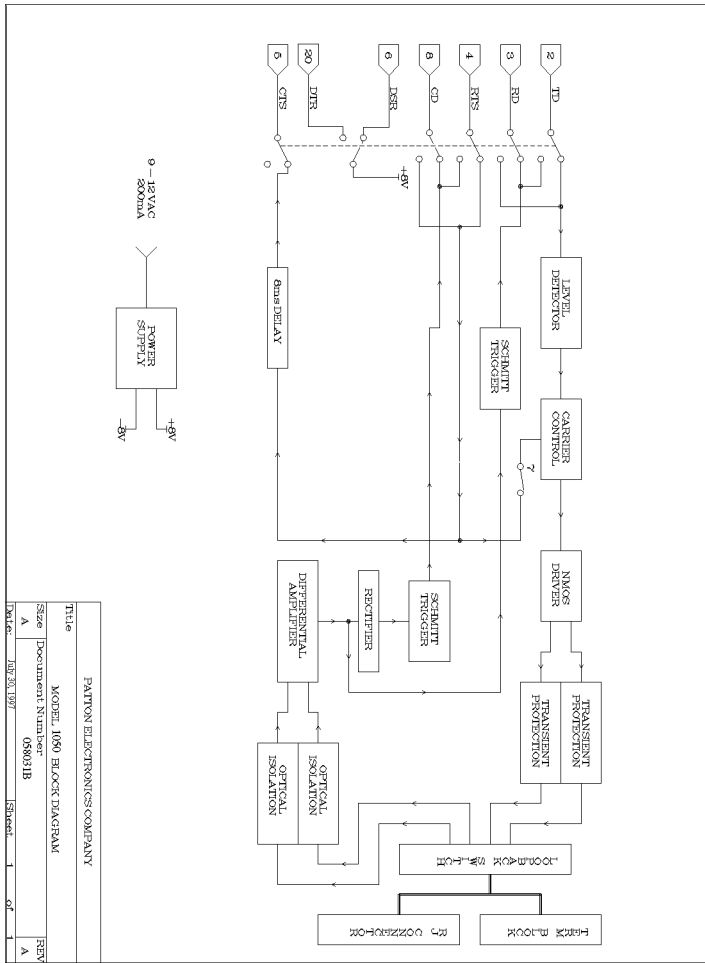

PATTON ELECTRONICS COMPANY			
Title	MODEL 1090 BLOCK DIAGRAM		
Size	Document Number	000011B	REV A
A	DATE	08/31/97	Sheet 1 of 1

Copyright © 1997
 Patton Electronics Company
 All Rights Reserved

Dear Valued Customer,

Thank you for purchasing Patton Electronics products! We do appreciate your business. I trust that you find this user manual helpful.

We manufacture one of the widest selections of data communications products in the world including CSU/DSU's, network termination units, powered and self-powered short range modems, fiber optic modems, interface converters, baluns, electronic data switches, data-line surge protectors, multiplexers, transceivers, hubs, print servers and much more. We produce these products at our Gaithersburg, MD, USA, facility, and can custom manufacture products for your unique needs.

We would like to hear from you. Please contact us in any of the following ways to tell us how you like this product and how we can meet your product needs today and in the future.

Web: <http://www.patton.com>
 Sales E-mail: sales@patton.com
 Support E-mail: support@patton.com
 Phone - Sales (301) 975-1000
 Phone - Support (301) 975-1007
 Fax: (301) 869-9293
 Mail: Patton Electronics Company
 7622 Rickenbacker Drive
 Gaithersburg, MD 20879 USA

We are committed to a quality product at a quality price. Patton Electronics is BABT and ISO 9001 certified. We meet and exceed the highest standards in the industry (CE, UL, etc.).

It is our business to serve you. If you are not satisfied with any aspect of this product or the service provided from Patton Electronics or its distributors, please let us know.

Thank you.

Burton A. Patton
 Vice President

P.S. Please tell us where you purchased this product:
