

# USER MANUAL

---

## MODEL 1075 KiloModem II AC Powered, High-Speed X.21 Short-Range Modem



**PATTON**  
**Electronics Co.**



An ISO-9001  
Certified Company

Part #07M1075-B  
Doc: 054081U, Rev. C  
Revised 1/23/08

SALES OFFICE  
(301) 975-1000  
TECHNICAL SUPPORT  
(301) 975-1007  
<http://www.patton.com>

## **1.0 WARRANTY INFORMATION**

**Patton Electronics** warrants all Model 1075 components to be free from defects, and will—at our option—repair or replace the product should it fail within one year from the first date of shipment.

This warranty is limited to defects in workmanship or materials, and does not cover customer damage, abuse or unauthorized modification. If this product fails or does not perform as warranted, your sole recourse shall be repair or replacement as described above. Under no condition shall **Patton Electronics** be liable for any damages incurred by the use of this product. These damages include, but are not limited to, the following: lost profits, lost savings and incidental or consequential damages arising from the use of or inability to use this product. **Patton Electronics** specifically disclaims all other warranties, expressed or implied, and the installation or use of this product shall be deemed an acceptance of these terms by the user.

### **1.1 RADIO AND TV INTERFERENCE**

The Model 1075 generates and uses radio frequency energy, and if not installed and used properly—that is, in strict accordance with the manufacturer's instructions—may cause interference to radio and television reception. The Model 1075 has been tested and found to comply with the limits for a Class A computing device in accordance with the specifications in Subpart J of Part 15 of FCC rules, which are designed to provide reasonable protection from such interference in a commercial installation. However, there is no guarantee that interference will not occur in a particular installation. If the Model 1075 does cause interference to radio or television reception, which can be determined by disconnecting the unit, the user is encouraged to try to correct the interference by one or more of the following measures: moving the computing equipment away from the receiver, re-orienting the receiving antenna and/or plugging the receiving equipment into a different AC outlet (such that the computing equipment and receiver are on different branches).

### **1.2 CE NOTICE**

The CE symbol on your Patton Electronics equipment indicates that it is in compliance with the Electromagnetic Compatibility (EMC) directive and the Low Voltage Directive (LVD) of the Union European (EU). A Certificate of Compliance is available by contacting Patton Technical Support.

### **1.3 SERVICE**

All warranty and nonwarranty repairs must be returned freight prepaid and insured to Patton Electronics. All returns must have a Return Materials Authorization number on the outside of the shipping container. This number may be obtained from Patton Electronics Technical Service: **(301) 975-1007**; <http://www.patton.com>: or, **support@patton.com**.

**NOTE:** Packages received without an RMA number will not be accepted.

Patton Electronics' technical staff is also available to answer any questions that might arise concerning the installation or use of your Model 1075. Technical Service hours: **8AM to 5PM EST, Monday through Friday**.

## 2.0 GENERAL INFORMATION

Thank you for your purchase of this Patton Electronics product. This product has been thoroughly inspected and tested and is warranted for One Year parts and labor. If any questions or problems arise during installation or use of this product, please do not hesitate to contact Patton Electronics Customer Service at (301) 975-1007.

### 2.1 FEATURES

- Data rates of 32, 56 and 64 kbps
- Distances to 6 miles (9.7km)
- Switch-selectable carrier control
- Synchronous X.21 operation
- Frequency Shift Keying (FSK) modulation
- DCE/DTE Switchable
- Point-to-point operation over 2 unconditioned twisted pair
- V.54 loopback tests and V.52 compliant BER tests
- 6 LED indicators
- Externally powered
- Transformer isolation
- Silicon Avalanche Diode surge protection
- Made in the U.S.A.

### 2.2 DESCRIPTION

#### **The Model 1075 KiloModem II X.21 Short Range Modem**

supports synchronous data rates of 32, 56 and 64 Kbps. Synchronous transmit clock options are internal, external and receive recover clock. Deriving power from a 9V DC wall-mount transformer, the Model 1075 supports extended distances to 6 miles (9.7km) over 2 unconditioned twisted pairs.

The Model 1075 incorporates two V.54 test modes (local analog loop and remote digital loop) that are activated by a tiny front panel switch. In addition, a built-in V.52 Bit Error Test (BER) test generator that outputs 511 and 511E bit patterns can also be controlled by a switch on the case. Six LED indicators monitor transmit data, receive data, control, indication, test mode (TM) and Error Status (ER). For protection against ground loops and transient surges, the Model 1075 incorporates both isolation transformers and Silicon Avalanche Diode surge suppressors.

Housed in a miniature ABS plastic case, the Model 1075 comes equipped with a female DB-15 connector and a choice of twisted pair interfaces (RJ-11 jack or RJ-45 jack).

### 3.0 CONFIGURATION

The Model 1075 is easy to install and is ruggedly designed for excellent reliability. The following instructions will help you to properly configure the Model 1075.

#### 3.1 CONFIGURATION SWITCHES

The Model 1075 uses a unique set of 16 external mini DIP switches that allow configuration to wide range of applications. The 16 external switches are grouped into two eight-switch sets, and are externally accessible from the underside of the Model 1075 (See Figure 1).

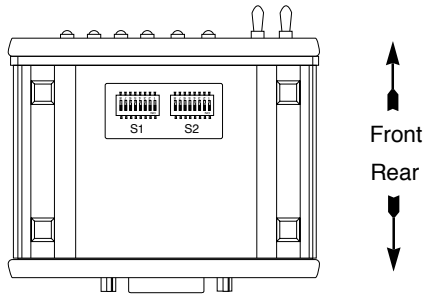

Figure 1. Underside of the 1075 Showing Location of DIP Switches

The two sets of DIP switches on the underside of the Model 1075 will be referred to as S1, S2. Figure 2 shows the orientation of DIP Switches S1 and S2 with respect to "ON" and "OFF" positions.

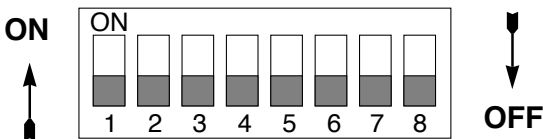

Figure 2. Close-up of DIP Switches Showing "ON" / "OFF" Positions

### 3.1.1 Configuration Switch Set “S1”

The switches on Switch S1 set V.54 Test Functions. Default settings and detailed descriptions for each switch are shown below.

S1 SUMMARY TABLE		
Position	Function	Factory Default
S1-1 thru S1-7	Not Assigned	Off
S1-8	V.54 Test Functions	Off Enabled

#### Switches S1-1 through S1-7: Not Assigned

#### Switch S1-8: V.54 Test Functions

Switch S1-8 enables or disables the Model 1075 V.54 loopback test modes.

<u>S1-8</u>	<u>Activation</u>	<u>Description</u>
Off	Enabled	V.54 test functions enabled
On	Disabled	V.54 test functions disabled

### 3.1.2 Configuration Switch Set “S2”

The switches on Switch S2 set data rates, clock source, carrier control and front panel switch operation. Default settings and detailed descriptions for each switch are shown below.

S2 SUMMARY TABLE		
Position	Function	Factory Default
S2-1	Data Rate	On } 56 kbps
S2-2	Data Rate	Off }
S2-3	Clock Mode	On } Internal
S2-4	Clock Mode	On }
S2-5	Carrier Control	Off Forced On
S2-6	Not Assigned	Off
S2-7	Not Assigned	Off
S2-8	Front Panel Switches	On Enabled

### Switches S2-1 and S2-2: Data Rate

Switches S2-1 and S2-2 are set in combination to determine the synchronous data rate for the Model 1075.

<u>S2-1</u>	<u>S2-2</u>	<u>Setting</u>
Off	On	32 kbps
On	Off	56 kbps
On	On	64 kbps

### Switches S2-3 and S2-4: System Clock Mode

The setting for switches S2-3 and S2-4 determines the transmitter clocking mode for the Model 1075.

<u>S2-3</u>	<u>S2-4</u>	<u>Clock Mode</u>	<u>Description</u>
On	On	Internal	System clock generated internally
On	Off	External (DTE)	System clock derived from terminal interface
Off	On	Receive Recover	System clock derived from the received line signal.

### Switch S2-5: Carrier Control

<u>S2-5</u>	<u>Carrier</u>	<u>Description</u>
Off	Always On	Transmitter is always ON
On	Follows terminal	Transmitter controlled by "Control" signal from X.21DTE (or by "Indication" signal from X.21 DCE)

### Switches S2-6 and S2-7: Not Assigned

#### Switch S2-8: Front Panel Switch Enable/Disable

Switch S2-8 determines whether the front panel switches may be used to perform diagnostic functions.

<u>S2-8</u>	<u>Activation</u>	<u>Description</u>
On	Enabled	Front panel switches may be used to activate/terminate diagnostics.
Off	Disabled	Front panel switches will have no effect on operation of the unit.

## 3.2 CONFIGURATION STRAPS

In addition to the configuration switches described above, the Model 1075 is also equipped with two internal straps that set the DTE/DCE Configuration and the DB-15 Shield. In order to configure these straps, you must open the Model 1075 case.

**NOTE:** Before opening the case, determine whether the default settings are correct for your application (see Sections 3.2.3 and 3.2.4)

### 3.2.1 Opening the Case

To open the Model 1075 insert a flat head screw driver into an open slot on either side of the case, as in Figure 3. Twist the screw driver head slightly and the top half of the case will separate from the lower half, as in Figure 4, below.

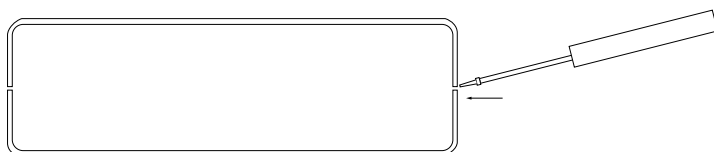

Figure 3. Opening the 1075 Case with a Small Screwdriver

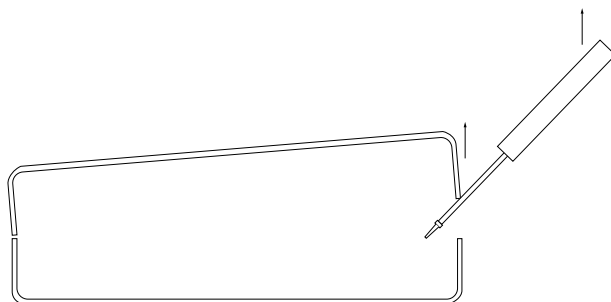

Figure 4. Opening the 1075 Case With a Small Screwdriver

To close the case, fit the 2 halves together snugly and snap them back in place.



### 3.2.2 Location of the Internal Straps

Figure 5 (below) shows the location of the DCE/DTE switch and the JP1 strap on top side of the the PC board.

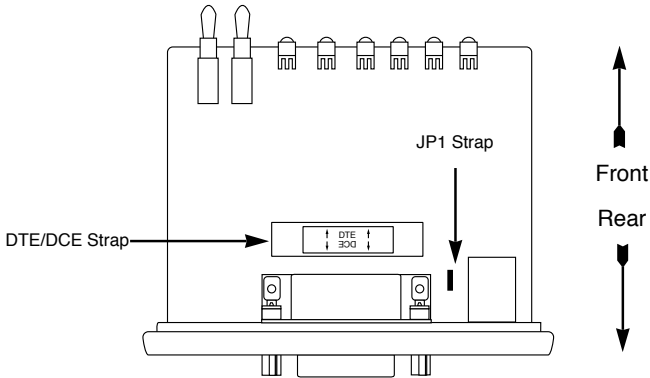

Figure 5 . Position of DTE/DCE and JP1 Jumper Straps on Model 1075 PC Board

### 3.2.3 Setting the DCE/DTE Strap

The X.21 interface on the Model 1075 is DCE/DTE switchable. **The default setting is DCE**, based upon how the Model 1075 sees its *own* orientation. When configured this way, the Model 1075 will want to connect to an X.21 DTE device. Re-positioning the DCE/DTE strap will enable the Model 1075 to connect to an X.21 DCE device (See Figure 6, below).

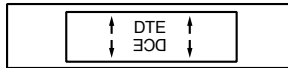

Figure 6 . Close-Up of Model 1075 PC Board With Close-up of DCE/DTE Strap  
Default Setting = "DCE"

The X.21 DCE/DTE strap is located near the DB-15 connector on the PC board. The arrows on the top of the strap indicate the configuration of the Model 1075. For example, if the DCE arrows are pointing toward the DB-15 Connector, the Model 1075 is configured as a "DCE" and must connect to an X.21 DTE device.

To change the DCE/DTE orientation of the Model 1075 X.21 interface, simply remove the strap and rotate it 180° so the appropriate arrows are pointing toward the DB-15 Connector.

### 3.2.4 Setting the JP1 Shield Strap

The setting of JP1 determines whether the shield (pin 1) of the X.21 interface is connected signal ground. In the default setting, DB-15 shield is connected to signal ground. The X.21 shield is not connected to signal ground when the jumper is placed on pins 1 and 2. See Figure 7, below.

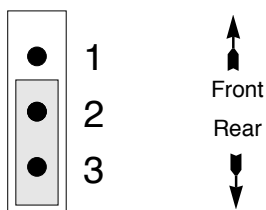

Figure 7. Jumper JP1 Orientation on the PC board

#### Jumper 1: DB15 Shield

<u>Position</u>	<u>DB15 Shield</u>
1-2	Not connected to signal ground
2-3	Connected to signal ground ( <i>default</i> )

## 4.0 INSTALLATION

When you have properly configured the configuration switches and straps, you are ready to connect the Model 1075 to connect to your system. This section tells you how to properly connect the Model 1075 to the twisted pair.

### 4.1 CONNECTION TO THE TWISTED PAIR INTERFACE

The Model 1075 supports full or half duplex communication between two X.21 devices at distances to 6 miles (9.7 km) and data rates to 64 kbps. There are two essential requirements for installing the Model 1075:

1. These units work in **pairs**. Therefore, you must have one Model 1075 (or compatible unit) at each end of a two twisted pair interface.
2. To function properly, the Model 1075 needs two twisted pairs of metallic wire. These pairs must be **unconditioned**, dry metallic wire, between 19 and 26 AWG (the higher number gauges may limit distance somewhat). Standard dial-up telephone circuits, or leased circuits that run through signal equalization equipment, are **not acceptable**.

For your convenience, the Model 1075 is available with two different twisted pair interface options: RJ-11 jack or RJ-45 jack.

#### 4.1.1 Twisted Pair Connection Using RJ-11 OR RJ-45

The RJ-11 and RJ-45 connectors on the Model 1075's twisted pair interface are pre-wired for a standard TELCO wiring environment. The signal/pin relationships are shown below.

<u>RJ-11</u>	<u>SIGNAL</u>	<u>RJ-45</u>	<u>SIGNAL</u>
1 .....	GND	1 .....	N/C
2 .....	RCV	2 .....	GND
3 .....	XMT	3 .....	RCV
4 .....	XMT	4 .....	XMT
5 .....	RCV	5 .....	XMT
6 .....	GND	6 .....	RCV
		7 .....	GND
		8 .....	N/C

When connecting two Model 1075s, it is necessary to use a "cross-over" cable. The diagram below shows how a cross-over cable should be constructed for an environment where both Model 1075s use a 8-wire RJ-45 connector. Similar logic should be followed when using RJ-11 connectors or a combination of the two.

**RJ-45 Cable (8-Wire)**

<b><u>SIGNAL</u></b>	<b><u>PIN#</u></b>	<b><u>PIN#</u></b>	<b><u>SIGNAL</u></b>
N/C	1	1	N/C
GND <sup>†</sup>	2-----	7	GND <sup>†</sup>
RCV	3-----	5	XMT
XMT	4-----	6	RCV
XMT	5-----	3	RCV
RCV	6-----	4	XMT
GND <sup>†</sup>	7-----	2	GND <sup>†</sup>
N/C	8	8	N/C

<sup>†</sup>Connection to ground is optional

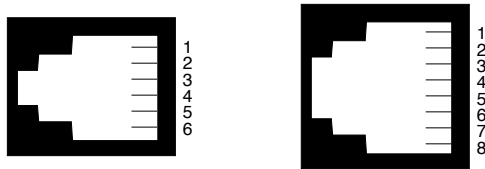

**Figure 8.** Pin Number Assignments for RJ11 and RJ45 Modular Jacks

**4.2 CONNECTION TO X.21 INTERFACE**

To connect the Model 1075 to a piece of data terminal or data communications hardware, use a *straight through* DB-15 cable. Plug the cable directly into the DB-25 port on the rear of the Model 1060.

If it is necessary to construct a special interface cable, please refer to the pinout diagrams in **Appendix C**.

**Notice!** Any terminal cable connected to the Model 1075 must be shielded cable, and the outer shield must be 360 degree bonded—at both ends—to a metal or metalized backshell.

### 4.3 AC POWER CONNECTIONS

Power is supplied to the Model 1075 by a 9 VDC, 1 A wall mount transformer. This transformer connects to the Model 1075 by means of a cannon jack on the rear panel. The Model 1075 is powered-up as soon as it is plugged into an AC outlet—there is no power switch.

#### 120 VAC Power (US)

The 120 VAC adapter supplied with the standard version of the Model 1075 is a “wall mount” type, and may be plugged into any approved 120 VAC wall plug.

#### 230 VAC Power (IEC)

The 230 VAC adapter supplied with the international version of the Model 1075 is equipped with an IEC-320 shrouded male connector. This connects with one of several available country-specific power cords (see the ordering information in **Appendix C.**) You may purchase these power cords from Patton Electronics at: **(301) 975-1007**; **<http://www.patton.com>**; or, **[support@patton.com](mailto:support@patton.com)**; or from a local vendor.

## 5.0 OPERATION

Once the Model 1075 is properly configured and installed, it should operate transparently—as if it were a standard cable connection. Section 5.0 describes the LED status monitors and the built-in V.52 and V.54 test modes. The Model 1075 is powered by a 9V DC external wall mount transformer. To power up the unit, connect the power supply cord to the power jack on the rear of the Model 1075 and plug the power adapter into the wall. There is no ON/OFF switch.

### 5.1 LED STATUS MONITORS

The Model 1075 features six front panel LEDs that indicate the status of the unit and the communication link. Figure 9 shows the front panel location of each LED. Following Figure 9 is a description of each LEDs function.

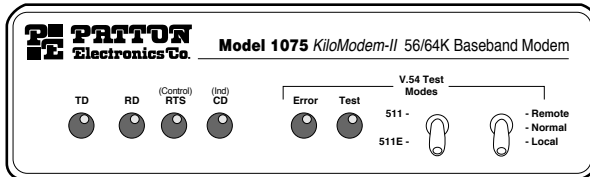

Figure 9 - Front Panel of the Patton Model 1075

- |                   |  |
|-------------------|--|
| <b>TD</b>         | (Transmit Data) Glows red to indicate an idle condition or binary 1 data. Glows green to indicate an active condition or binary 0 data. Glows orange to indicate rapidly changing data. Source: DTE. |
| <b>RD</b>         | (Receive Data) Glows red to indicate an idle condition or binary 1 data. Glows green to indicate an active condition or binary 0 data. Glows orange to indicate rapidly changing data. Source: DCE.  |
| <b>Control</b>    | Glows green to indicate that Control from DTE is active. Red indicates that Control from the DTE is inactive.  |
| <b>Indication</b> | Glows green to indicate that the Indication from DCE is active. Red indicates that the Indication from the DCE is inactive.  |
| <b>Error</b>      | Glows red when errors are detected during the 511 or 511/E BER tests.  |
| <b>Test</b>       | Glows red when the V.54 loopback test or V.52 BER tests are initiated.   |

## 5.2 TEST MODES

The Model 1075 offers two V.54 test modes to evaluate the condition of the modems and the communication link. These tests are activated from the front panel.

### 5.2.1 Local Analog Loopback (LAL)

The Local Analog Loopback (LAL) test checks the operation of the local Model 1075, and is performed separately on each unit. Any data sent to the local Model 1075 in this test mode will be echoed (returned) back to the user device. For example, characters typed on the keyboard of a terminal will appear on the terminal screen. To perform a LAL test, follow these steps.

- A. Activate LAL. This may be done by moving the front panel toggle switch **DOWN** to LAL. Once LAL is activated, the Model 1075 transmitter output is connected to its own receiver. The test LED should be lit.
- B. Verify that the data terminal equipment is operating properly and can be used for a test. If a fault is indicated, call a technician or replace the unit.
- C. Perform a Bit Error Rate (BER) test on each unit. If the BER test equipment indicates no faults, but the data terminal indicates a fault, follow the manufacturer's checkout procedures for the data terminal. Also, check the interface cable between the terminal and the Model 1075.

### 5.2.2 Remote Digital Loopback (RDL)

The RDL test checks the performance of both the local and remote Model 1075, and the communication link between them. Any characters sent to the remote Model 1075 in this test mode will be returned back to the originating device. For example, characters typed on the keyboard of the local terminal will appear on the local terminal screen after having been passed to the remote Model 1075 and looped back. To perform an RDL test, follow these steps:

- A. Activate RDL by moving the front panel toggle switch UP to RDL.
- B. Perform a BER test on the system.

(cont)

- C. If the BER test equipment indicates a fault, and the Local Analog Loopback test was successful for both Model 1075s, you may have a problem with the twisted pair line between the modems. You should then check the twisted pair line for proper connections and continuity.

### 5.2.3 How to Use the V.52 BER Test Independently

The V.52 BER test can be used independently of the V.54 loopback tests. This requires two operators: one to initiate and monitor the test at the local Model 1075, and one at the remote Model 1075. To use the V.52 BER test by itself, both operators should simultaneously follow these steps:

1. Locate the 511/511E toggle switch on the front panel of the 1075 and move it **UP**. This activates the V.52 BER test mode and transmits a 511 test pattern to the other unit. If any errors are present, the receiving modem's red Error LED will blink sporadically. For this test to work, make sure the 511 switch on both Model 1075s is on.
2. If the test indicates no errors are present, move the V.52 toggle switch **DOWN**, activating the 511/E test with errors present. If the test is working properly, the receiving modem's red Error LED will blink regularly. A successful 511/E test will confirm that the link is in place, and that the Model 1075's built in 511 generator and detector are working properly.

### 5.3 POWER-DOWN

There is no power switch on the Model 1075. You turn it off by unplugging the AC power adapter from the wall.



## **APPENDIX A**

### **PATTON MODEL 1075 SPECIFICATIONS**

<b>Approvals:</b>	CE European Directives
<b>DTE/DCE I/F:</b>	X.21 DB15F DCE or DTE, EIA RS-422 Compliant
<b>Compatibility:</b>	1035, 1045 , 1075, 1080A, 1090 series units
<b>Transmission Format:</b>	Synchronous
<b>Transmission Line Interface:</b>	Unconditioned twisted pair 19 - 26 AWG Externally accessible RJ-45 (RJ-11 Optional)
<b>Clock</b>	Internal, External and Network (Receive Recover)
<b>Distance:</b>	Up to 6 miles (9.7km)
<b>Interfaces:</b>	CCITT/ITU X.21
<b>Data Rates:</b>	32, 56 and 64 Kbps (switch selectable)
<b>Isolation:</b>	1500V RMS via isolation transformers
<b>Surge Protection:</b>	IEC-801-S, Level 2, 1kV
<b>Carrier Control</b>	Constantly on or Controlled by "Control" from DTE device (DCE mode) or "Indication" from DCE device (DTE mode)
<b>Connectors:</b>	DB-15 female RJ-11 or RJ-45 on line side
<b>Power Supply:</b>	9V DC wall-mount transformer, 200mA
<b>Temperature Range:</b>	0-60°C (32-140°F)
<b>Altitude:</b>	0-15,000 feet
<b>Humidity:</b>	5 to 95% noncondensing
<b>Dimensions:</b>	1.54H x 4.1"W x 3.7"D
<b>Power Options:</b>	120 VAC 50/60Hz, external transformer; 230 VAC 50/60Hz, external transformer
<b>Weight:</b>	2.5 lbs. (1.1 Kg)

## APPENDIX B

### MODEL 1075 FACTORY REPLACEMENT PARTS AND ACCESSORIES

<u>Patton Model #</u>	<u>Description</u>
1075 .....	KiloModem II X.21 Short Range Modem
0805B .....	120V Wall Mount AC Adapter
08059DCI .....	230V AC Adapter (No Power Cord)
0805US .....	American Power Cord
0805EUR.....	European Power Cord CEE 7
0805UK .....	United Kingdom Power Cord
0805AUS .....	Australia/New Zealand Power Cord
0805DEN.....	Denmark Power Cord
0805FR.....	France/Belgium Power Cord
0805IN.....	India Power Cord
0805IS.....	Israel Power Cord
0805JAP.....	Japan Power Cord
0805SW.....	Switzerland Power Cord

**APPENDIX C**  
**MODEL 1075 X.21 Interface**  
**DB15 Female**

<u>Pin</u>	<u>Signal</u>	<u>Source</u>
1	Shield	-
2	Transmit (a)	DTE
3	Control (a)	DTE
4	Receive (a)	DCE
5	Indication (a)	DCE
6	System Clock (a)	DCE
7	-	-
8	Signal Ground	-
9	Transmit (b)	DTE
10	Control (b)	DTE
11	Receive (b)	DCE
12	Indication (b)	DCE
13	System Clock (b)	DCE
14	-	-
15	-	-

# APPENDIX D

## MODEL 1075 PIN CONFIGURATIONS BLOCK DIAGRAM

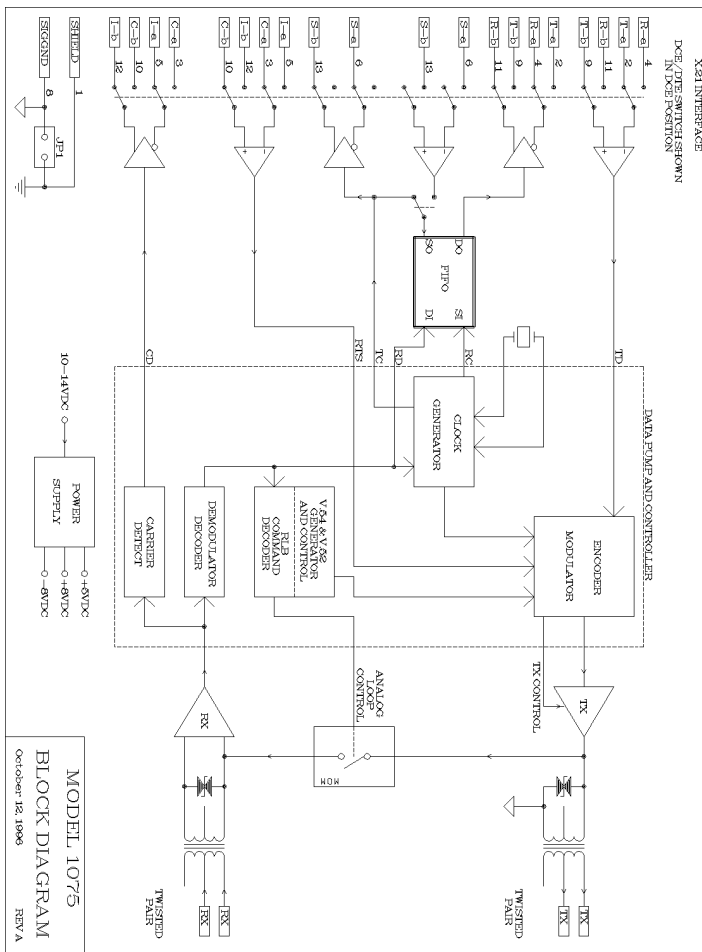







Dear Valued Customer,

Thank you for purchasing Patton Electronics products! We do appreciate your business. I trust that you find this user manual helpful.

We manufacture one of the widest selections of data communications products in the world including CSU/DSU's, network termination units, powered and self-powered short range modems, fiber optic modems, interface converters, baluns, electronic data switches, data-line surge protectors, multiplexers, transceivers, hubs, print servers and much more. We produce these products at our Gaithersburg, MD, USA, facility, and can custom manufacture products for your unique needs.

We would like to hear from you. Please contact us in any of the following ways to tell us how you like this product and how we can meet your product needs today and in the future.

Web:	<a href="http://www.patton.com">http://www.patton.com</a>
Sales E-mail:	<a href="mailto:sales@patton.com">sales@patton.com</a>
Support E-mail:	<a href="mailto:support@patton.com">support@patton.com</a>
Phone - Sales	(301) 975-1000
Phone - Support	(301) 975-1007
Fax:	(301) 869-9293
Mail:	Patton Electronics Company 7622 Rickenbacker Drive Gaithersburg, MD 20879 USA

We are committed to a quality product at a quality price. Patton Electronics is ISO 9001 certified. We meet and exceed the highest standards in the industry (CE, UL, etc.).

It is our business to serve you. If you are not satisfied with any aspect of this product or the service provided from Patton Electronics or its distributors, please let us know.

Thank you.

Burton A. Patton  
Vice President

P.S. Please tell us where you purchased this product:

---

---

---

---

---

---