

USER MANUAL

MODEL 2014
Interface Powered
RS-530 to V.35 Converter



PATTON
Electronics Co.



*An ISO-9001
Certified Company*

Part #07M2014-C
Doc. #070011UC
Revised 4/22/98

SALES OFFICE
(301) 975-1000
TECHNICAL SUPPORT
(301) 975-1007
<http://www.patton.com>

1.0 WARRANTY INFORMATION

Patton Electronics warrants all Model 2014 components to be free from defects, and will—at our option—repair or replace the product should it fail within one year from the first date of shipment.

This warranty is limited to defects in workmanship or materials, and does not cover customer damage, abuse or unauthorized modification. If this product fails or does not perform as warranted, your sole recourse shall be repair or replacement as described above. Under no condition shall **Patton Electronics** be liable for any damages incurred by the use of this product. These damages include, but are not limited to, the following: lost profits, lost savings and incidental or consequential damages arising from the use of or inability to use this product. **Patton Electronics** specifically disclaims all other warranties, expressed or implied, and the installation or use of this product shall be deemed an acceptance of these terms by the user.

1.1 RADIO AND TV INTERFERENCE

The Model 2014 generates and uses radio frequency energy, and if not installed and used properly—that is, in strict accordance with the manufacturer's instructions—may cause interference to radio and television reception. The Model 2014 has been tested and found to comply with the limits for a Class A computing device in accordance with the specifications in Subpart J of Part 15 of FCC rules, which are designed to provide reasonable protection from such interference in a commercial installation. However, there is no guarantee that interference will not occur in a particular installation. If the Model 2014 does cause interference to radio or television reception, which can be determined by disconnecting the RS-530 or V.35 interface, the user is encouraged to try to correct the interference by one or more of the following measures: moving the computing equipment away from the receiver, re-orienting the receiving antenna and/or plugging the receiving equipment into a different AC outlet (such that the computing equipment and receiver are on different branches).

1.2 CE NOTICE

The CE symbol on your Patton Electronics equipment indicates that it is in compliance with the Electromagnetic Compatibility (EMC) directive and the Low Voltage Directive (LVD) of the Union European (EU). A Certificate of Compliance is available by contacting Patton Technical Support.

1.3 SERVICE

All warranty and nonwarranty repairs must be returned freight prepaid and insured to Patton Electronics. All returns must have a Return Materials Authorization number on the outside of the shipping container. This number may be obtained from Patton Electronics Technical Service at

telephone: **(301) 975-1007**,
web address: **<http://www.patton.com>**;
email: **support@patton.com**.

NOTE: Packages received without an RMA number will not be accepted.

Patton Electronics' technical staff is also available to answer any questions that might arise concerning the installation or use of your Model 2014. Technical Service hours: **8AM to 5PM EST, Monday through Friday.**

2.0 GENERAL INFORMATION

Thank you for your purchase of this Patton Electronics product. This product has been thoroughly inspected and tested and is warranted for One Year parts and labor.

If any questions or problems arise during installation or use of this product, please do not hesitate to contact Patton Electronics Technical Support at (301) 975-1007.

2.1 FEATURES

- Bi-directionally converts synchronous RS-530 to V.35
- Data rates to 2 Mbps, full or half duplex
- Transparent to protocol
- No AC power or batteries required
- Various DCE/DTE combinations available
- DB-25 and M/34 connectors with integral 6 foot cable
- Circuitry housed in a miniature case
- Made in the USA

2.2 DESCRIPTION

The **Model 2014 RS-530 to V.35 converter** lets a synchronous RS-530 device communicate bi-directionally with a synchronous V.35 device. The Model 2014 requires no AC power or batteries to operate and supports data rates to 2 Mbps. Operating full or half duplex, the Model 2014 passes all necessary clocking and control signals, and is transparent to protocol.

The Patton Model 2014 connects directly to the synchronous RS-530 interface using a male or female DB-25 connector. A male or female M/34 connector at the end of an integral 6 foot cable plugs into the V.35 device. Models with any combination of "DCE" and "DTE" wiring are available, thus eliminating the need for special crossover cables.

Housed in an ultra-miniature case measuring only 2.66" x 2.10" x 0.73", the Model 2014 fits easily into tight locations. Like all Patton products, the Model 2014 is manufactured by Patton Electronics in the USA.

3.0 INSTALLATION

The Patton Model 2014 is very simple to install. Just plug it in like a normal cable and you're ready to go: no configuration is necessary! Since the Model 2014 is available in various combinations of genders and DCE/DTE orientations, many applications are possible. Figures 1 and 2 show two possible applications for the Model 2014.



Figure 1. A common RS-530 DTE to V.35 DCE installation



Figure 2. A common V.35 DTE to RS-530 DCE installation

APPENDIX A

PATTON MODEL 2014 SPECIFICATIONS

Interfaces:	EIA RS-530/CCITT V.24 to ITU/CCITT V.35
Data Rates:	0 - 2 Mbps
Transmission Mode:	Full or half duplex
Protocol:	Transparent to protocol
Clocking:	Set by connected devices
Connectors:	DB-25 male or female on RS-530 side, M/34 male or female on V.35 side
Power Supply:	No external power required; uses power from NIC data and control signals
Temperature Range:	0-60°C (32-140°F)
Altitude:	0-15,000 feet (0-5,000 meters)
Humidity:	5 to 95% noncondensing
Dimensions:	2.66"L x 2.10"H x 0.73"W
Weight:	14 oz, including cable and connectors

APPENDIX B

PATTON MODEL 2014 DCE/DTE BLOCK DIAGRAM

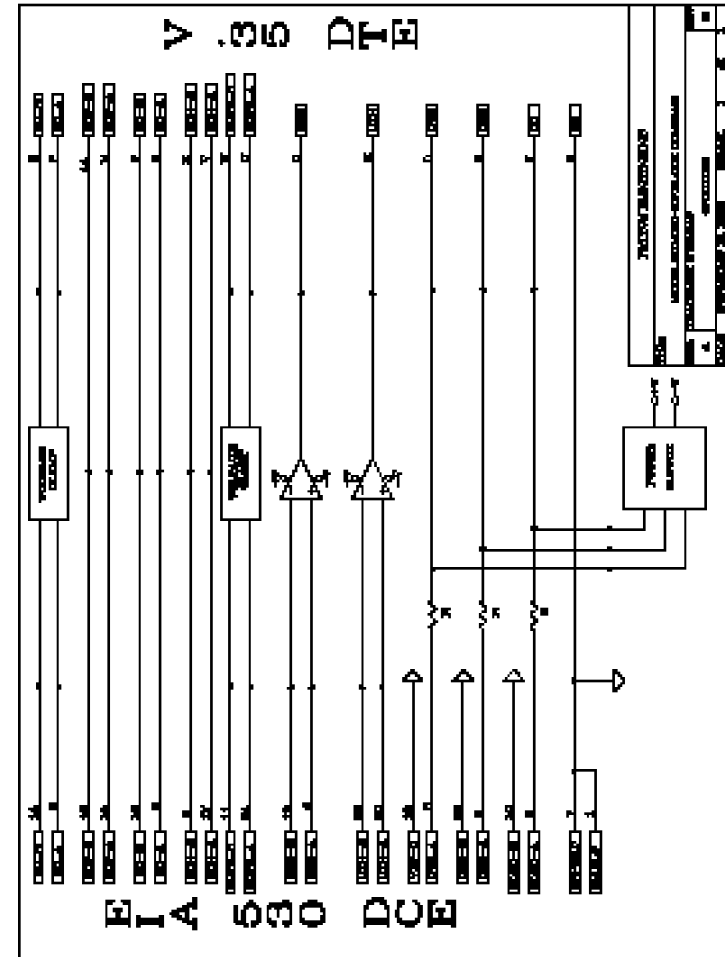

Applies to Models

2014MC-FT	2014FC-MT
2014MC-MT	2014FC-FT

**APPENDIX C
PATTON MODEL 2014 DTE/DCE BLOCK DIAGRAM**

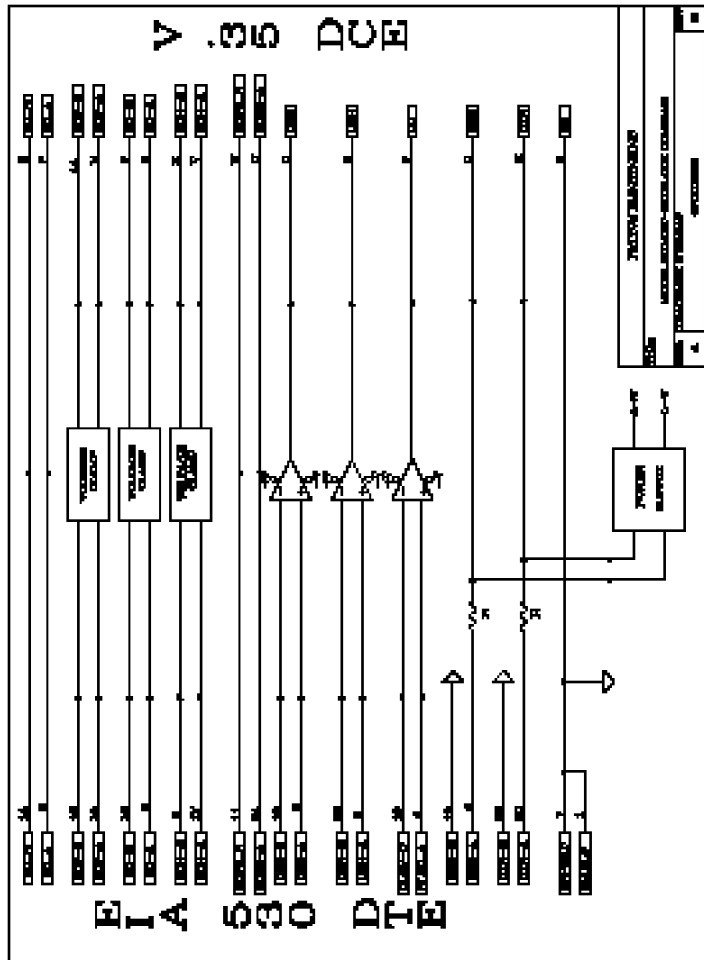

Applies to Models
 2014MT-FC 2014FT-MC
 2014MT-MC 2014FT-FC

**APPENDIX D
INTERFACE STANDARDS**

EIA 530 PIN-OUT REFERENCE (DB-25)

DTE	Transmitted Data (Return)	14	1	Protective Ground	Sig. Source
DCE	Transmit Clock	15	2	Transmitted Data	DTE
DCE	Received Data (Return)	16	3	Received Data	DCE
DCE	Receiver Clock	17	4	Request To Send	DTE
		18	5	Clear To Send	DCE
DTE	Request To Send (Return)	19	6	Data Set Ready	DCE
DTE	Data Terminal Ready	20	7	Signal Ground	DCE
		21	8	Carrier Detect	DCE
DTE	Data Set Ready (Return)	22	9	Receiver Clock (Return)	DCE
DTE	Data Terminal Ready (Return)	23	10	Carrier Detect (Return)	DCE
DTE	DTE Transmitter Clock	24	11	DTE Transmitter Clock (Return)	DTE
		25	12	Transmitter Clock (Return)	DCE
			13	Clear To Send (Return)	DCE

Model 2014 V.35 Interface (M/34 Male)

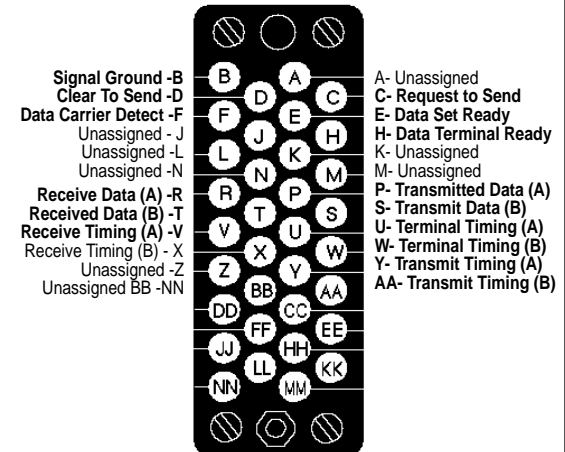

Copyright © 1998
 Patton Electronics Company
 All Rights Reserved