

USER MANUAL

MODEL 2020 and MODEL 2020N

Interface Powered
RS-232 to V.35 Converters



PA PATTON
Electronics Co.



An ISO-9001
Certified Company

Part #07M2020-E
Doc #077011UE
Revised 08/16/99

SALES OFFICE
(301) 975-1000
TECHNICAL SUPPORT
(301) 975-1007
<http://www.patton.com>

1.0 WARRANTY INFORMATION

Patton Electronics warrants all Model 2020 and 2020N components to be free from defects, and will--at our option--repair or replace the product should it fail within one year from the first date of shipment.

This warranty is limited to defects in workmanship or materials, and does not cover customer damage, abuse, or unauthorized modification. If this product fails or does not perform as warranted, your sole recourse shall be repair or replacement as described above. Under no condition shall **Patton Electronics** be liable for any damages incurred by the use of this product. These damages include, but are not limited to, the following: lost profits, lost savings, and incidental or consequential damages arising from the use of or inability to use this product.

Patton Electronics specifically disclaims all other warranties, expressed or implied, and the installation or use of this product shall be deemed an acceptance of these terms by the user.

1.1 RADIO AND TV INTERFERENCE

The Models 2020 and 2020N generate and use radio frequency energy, and if not installed and used properly--that is, in strict accordance with the manufacturer's instructions--may cause interference to radio and television reception. The Model 2020/2020N has been tested and found to comply with the limits for a Class A computing device in accordance with the specifications in Subpart J of Part 15 of FCC rules, which are designed to provide reasonable protection from such interference in a commercial installation. However, there is no guarantee that interference will not occur in a particular installation. If the Model 2020/2020N does cause interference to radio or television reception, which can be determined by disconnecting the RS-232 or V.35 interface, the user is encouraged to try to correct the interference by one or more of the following measures: moving the computing equipment away from the receiver, re-orienting the receiving antenna, and/or plugging the receiving equipment into a different AC outlet (such that the computing equipment and receiver are on different branches).

1.2 CE NOTICE

The CE symbol on your Patton Electronics equipment indicates that it is in compliance with the Electromagnetic Compatibility (EMC) directive and the Low Voltage Directive (LVD) of the Union European (EU). A Certificate of Compliance is available by contacting Technical Support.

1.3 SERVICE

All warranty and non-warranty repairs must be returned freight prepaid and insured to Patton Electronics. All returns must have a Return Materials Authorization number on the outside of the shipping container. This number may be obtained from Patton Electronics Technical Support: **(301) 975-1007**; <http://www.patton.com>; or, **support@patton.com**.

NOTE: Packages received without an RMA number will not be accepted.

Patton Electronics' technical staff is also available to answer any questions that might arise concerning the installation or use of your Model 2020 or 2020N. Technical Support hours: **8AM to 5PM EST, Monday through Friday.**

2.0 GENERAL INFORMATION

Thank you for your purchase of this Patton Electronics product. This product has been thoroughly inspected and tested and is warranted for One Year parts and labor. If any questions or problems arise during installation or use of this product, please do not hesitate to contact Patton Electronics Technical Support at (301)-975-1007.

2.1 FEATURES

- Bi-directionally converts synchronous RS-232 to V.35
- Data rates to **384 Kbps**, full or half duplex
- Transparent to protocol
- No AC power or batteries required
- DCE/DTE strap selectable
- DB-25 and M/34 connectors with integral 6 ft cable (Model 2020)
- Dual DB-25 connectors with integral 6ft cable (Model 2020-25)
- DB-25 and M/34 connectors in one plastic enclosure (Model 2020N)
- Circuitry housed in ultra-miniature case
- Made in the USA.

2.2 DESCRIPTION

The **Model 2020 and 2020N RS-232 to V.35 converters** let a synchronous RS-232 device communicate bi-directionally with a synchronous V.35 device. The Model 2020/2020N require no external AC power or batteries to operate and supports data rates to 384 Kbps. Operating full or half duplex, the Model 2020 passes all necessary clocking and control signals, and is transparent to protocol.

The Model 2020 connects directly to the synchronous RS-232 interface using a male or female DB-25 connector. A male or female M/34 connector at the end of an integral 6 ft cable plugs into the V.35 device. The Model 2020-25 substitutes a male or female DB-25 on the V.35 interface. The Model 2020N house both DB-25 and M/34 connectors within the same enclosure.

An internal DCE/DTE strap allows the user to configure the Model 2020/2020N as "DCE to DTE" or "DTE to DCE". In most cases, this eliminates the need for special crossover cables. Housed in an ultra-miniature case measuring only 2.66" x 2.10" x 0.73", the Model 2020 fits easily into tight locations. The Model 2020N measures a tiny 3.20"L x 2.10"H x 0.90"W.

3.0 CONFIGURATION

The Model 2020/2020N is designed to be easy to use. In most cases you will not need to configure the Model 2020/2020N in any way: just plug it in and go! The Model 2020 is transparent to protocol, including data rate and clocking method. The only configuration you may need to do is for DTE/DCE orientation. This procedure is described below.

3.1 SETTING DCE/DTE ORIENTATION

The Model 2020/2020N installs between DTE devices such as terminals and host computers, and DCE devices such as modems, multiplexers and CSU/DSUs. Most often the DTE device will be RS-232, and the DCE device will be V.35. Therefore, **the default DCE/DTE setting for the Model 2020 is RS-232 DCE to V.35 DTE**, based on how the Model 2020 "sees" its own orientation. For example, if the Model 2020 sees its own RS-232 port as DCE, it will want to plug into an RS-232 DTE device such as a terminal.

If you need to reverse the DCE/DTE orientation of the Model 2020 so that the RS-232 port is DTE and the V.35 port is DCE, follow the step-by-step instructions below (note: it is not possible to configure the Model 2020/2020N so that both ports are DTE or DCE).

3.1.1 OPENING THE CASE

The DCE/DTE strap on the Model 2020/2020N is located on the PC board. To access the PC board you will need to open the plastic case.

1. Simply insert a small flathead screwdriver or similar tool between the DB-25 connector and the lip of the case as shown in Figure 1, below.

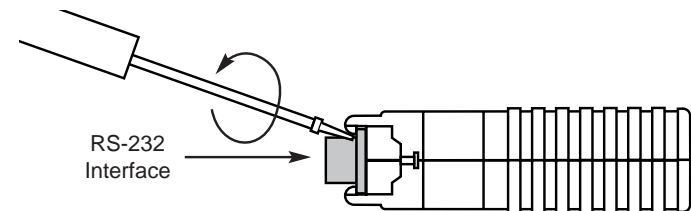

Figure 1. Inserting the screwdriver

2. Gently twist the screwdriver to pop the case open as shown in Figure 2, below. Be careful not to damage the case or connector as you twist the screw driver.

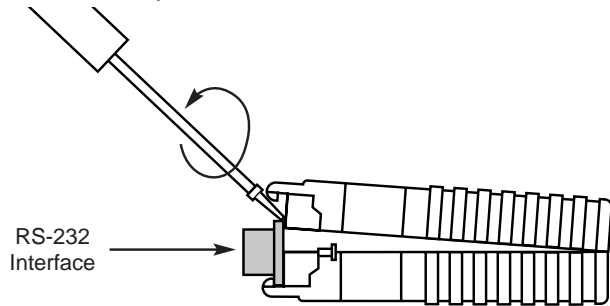

Figure 2. Popping open the case

3. Once you have opened the case of the Model 2020/2020N, you will see the DCE/DTE strap located on the PC board in the position shown in Figure 3, below. The **DCE/DTE strap is oriented closest to the RS-232 interface.**

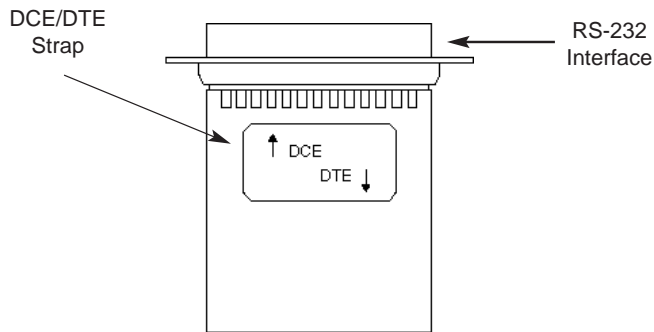

Figure 3. DCE/DTE strap orientation on PC board

4. The arrows on top of the strap indicate the orientation of the Model 2020's ports. For example, if the "DCE" arrow is pointing toward the DB-25 connector, then the Model 2020/2020N's RS-232 port is configured as a DCE and will connect to a RS-232 DTE port. The arrow pointing toward the cable at the rear of the PC board shows the orientation of the Model 2020's V.35 port.

5. To reverse the DCE/DTE orientation, pull the entire strap out of its socket and rotate it 180 degrees. Then plug it back into the socket. You will see that the arrows on top now point in the opposite directions showing the new DCE/DTE orientation of the Model 2020.
6. When you're done, realign the case halves (don't forget the captive screws and saddle washers) and snap them back together.

4.0 INSTALLATION

After you have configured the DCE/DTE strap, all you need to do is plug the Model 2020 or 2020N into the proper device ports. Figures 4 and 5 show how to install the Model 2020/2020N.

***NOTE:** The diagrams below show the Model 2020 in the installed application. If you are using a Model 2020N, connect the RS-232 interface directly to the RS-232 equipment and **connect the V.35 interface to the V.35 interface.**

4.1 CONNECTING AN RS-232 DTE TO A V.35 DCE*

Figure 4 (below) illustrates proper connection of an RS-232 DTE to a V.35 DCE using the Model 2020. The RS-232 interface of the Model 2020/2020N must be configured as DCE.

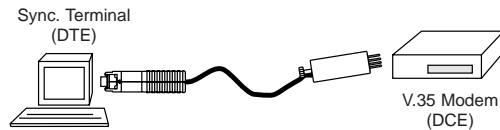

Figure 4. A Common RS-232 DTE to V.35 DCE Installation

4.2 CONNECTING A V.35 DTE TO AN RS-232 DCE*

Figure 5 (below) illustrates proper connection of a V.35 DTE to an RS-232 DCE using the Model 2020. The RS-232 interface of the Model 2020/2020N must be configured as DTE.

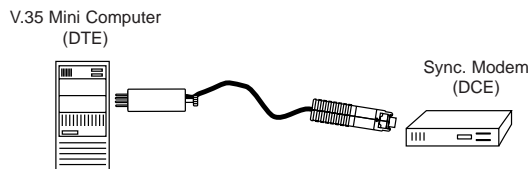

Figure 5. A common V.35 DTE to RS-232 DCE installation

4.3 CONNECTING THE MODEL 2020-25

The Model 2020-25 is connected the same way as the standard Model 2020, with the exception that the V.35 interface has a DB-25 connector instead of an M/34 connector. The DB-25 carries the same signals as the M/34, but is pinned according to the RS-530 Standard. Please refer to Appendix B for specific pin out information.

APPENDIX A.

MODEL 2020 AND 2020N SPECIFICATIONS

Interfaces:	EIA RS-232/ITU/CCITT V.24 to ITU/CCITT V.35/EIA RS-530
Data Rates:	0 - 384 Kbps
Transmission Mode:	Synchronous, full or half duplex
Protocol:	Transparent to protocol
Clocking:	Set by connected devices
Connectors:	All Versions: DB-25 male or female on RS-232 side; Model 2020: M/34 male or female on V.35 side at the end of 6 ft. cable. Model 2020-25: DB-25 male or female on V.35 side at the end of 6 ft. cable. Model 2020N: RS-232 Male or Female with M/34 male or female on V.35 side.
Power Supply:	None required. Uses power from interface data and control signals
Temperature Range:	0-60 degrees C (32-140 degrees F)
Altitude:	0-15,000 feet (0-5,000 meters)
Humidity:	5 to 95% noncondensing
Dimensions:	Model 2020: 2.66"L x 2.10"H x 0.73"W (6.76cmL x 5.33cmH x 1.85cmW) Model 2020N: 2.40"L x 1.73"H x 0.89"W (6.10cmL x 4.39cmH x 2.26cmW)
Weight:	Model 2020: 14 oz, including cable and connectors Model 2020N: 2.2 oz

APPENDIX B

V.35 INTERFACE STANDARDS

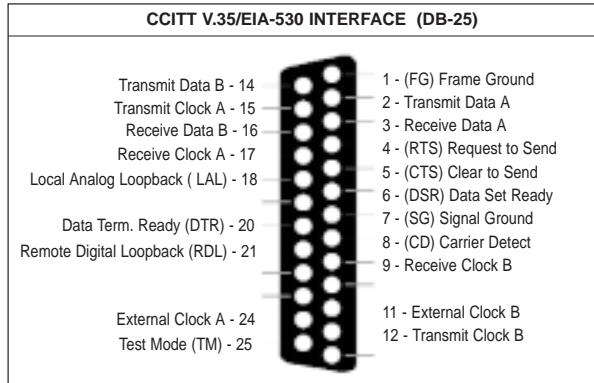

APPENDIX C

RS-232C/V.24 INTERFACE STANDARDS

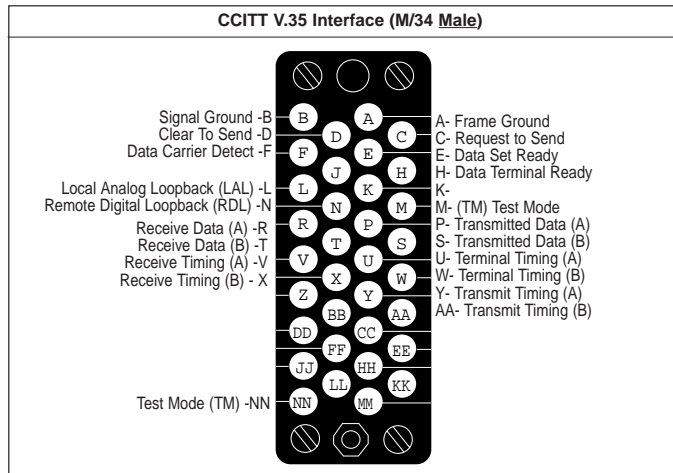
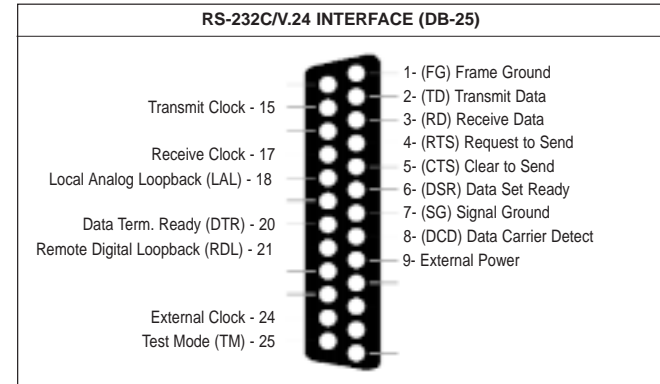

APPENDIX D

BLOCK DIAGRAM

