

Doc#: 172001UA
Part#: 07M2021P-A

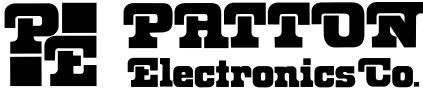

INTERFACE CONVERTER, V.24 TO X.21

2021P

(CTS IC-V.24/X.21)

INSTALLATION AND OPERATIONS MANUAL

February 21, 2000



An ISO-9001
Certified Company

Copyright© 2000 Patton Electronics Co., All Rights Reserved

Table of Contents

CHAPTER 1 - Operation

CHAPTER 2 - SETUP AND INSTALLATION

Installation	2-1
Selection of DTE/DCE	2-1
Equipment Grounding	2-3
LED Indicators	2-3
Factory Test Straps	2-3

APPENDIX

TECHNICAL SPECIFICATIONS	A-1
X.21 Interface Pins Supported	A-2
V.24 Interface Pins Supported	A-2

PROPRIETARY NOTICE

The information contained herein is proprietary and confidential to Patton Electronics Co. Any reproduction or redistribution of this publication, in whole or in part, is expressly prohibited unless written authorization is given by Patton Electronics Co.

SERVICE

All warranty and non-warranty repairs must be returned freight prepaid and insured to Patton Electronics. All returns must have a Return Materials Authorization number on the outside of the shipping container. This number may be obtained from Patton Electronics Technical Services at:

Tel: (301) 975-1007;
email: support@patton.com;
or, Web: <http://www.patton.com>.

NOTE: Packages received without an RMA number will not be accepted.

Patton Electronics' technical staff is also available to answer any questions that might arise concerning the installation or use of your Patton MSDs. Technical Service hours: 8AM to 5PM EST, Monday through Friday.

PUBLICATION NOTICE

This manual has been compiled and checked for accuracy. The information in this manual does not constitute a warranty of performance. Patton reserves the right to revise this publication and make changes from time to time in the content thereof. Patton assumes no liability for losses incurred as a result of out-of-date or incorrect information contained in this manual.

RADIO AND TV INTERFERENCE

The Patton devices generate and use radio frequency energy, and if not installed and used properly—that is, in strict accordance with the manufacturer's instructions—may cause interference to radio and television reception. The Patton devices have been tested and found to comply with the limits for Class A computing devices in accordance with the specifications in Subpart J of Part 15 of FCC rules, which are designed to provide reasonable protection from such interference in a commercial installation. However, there is no guarantee that interference will not occur in a particular installation. If the Patton devices do cause interference to radio or television reception, which can be determined by disconnecting the cables, the user is encouraged to try to correct the interference by one or more of the following measures: moving the computing equipment away from the receiver, re-orienting the receiving antenna, and/or plugging the receiving equipment into a different AC outlet (such that the computing equipment and receiver are on different branches).

Canadian EMISSIONS

This digital apparatus does not exceed the Class A limits for noise emissions from a digital apparatus set out in the Radio Interference Regulations of the Canadian Department of Communications.

Le présent appareil numérique n'émet pas de bruits radioélectriques dépassant les limites applicables aux appareils numériques de la Class A prescrites dans le Règlement sur le brouillage radioélectrique édicté par le ministère des Communications du Canada.

CHAPTER 1 - Operation

The Patton 2021P (CTS TCB-V.24/X.21) is an EIA RS-232 to CCITT X.21 interface converter with a built in tail circuit buffer, allowing modem to modem interconnection. The interface converter operates bi-directionally. DCE / DTE selection of each port permits interfacing an RS-232 terminal or modem to an X.21 terminal or modem. This interface converter can satisfy all interface conversion requirements. This adapter is ideal for High Speed Modems since it can operate at up to 128Kbps. Connection of two terminal devices is not supported because internal clocking is not provided by this device.

Devices can be separated up to 4000 feet away from the interface converter on the balanced interface side and RS-232 devices can be separated up to 50 feet away from the interface converter. The unit is supplied with a female DB-25 for the RS-232 port and a female DB-15 for the CCITT X.21 port.

The interface converter is housed in a sturdy aluminum enclosure and has an internal 110/220VAC switch selectable power supply. Sixteen of the interface converters will also fit into the MCS-16 card rack for convenient data center applications.

The unit can operate on standard power found in most countries.

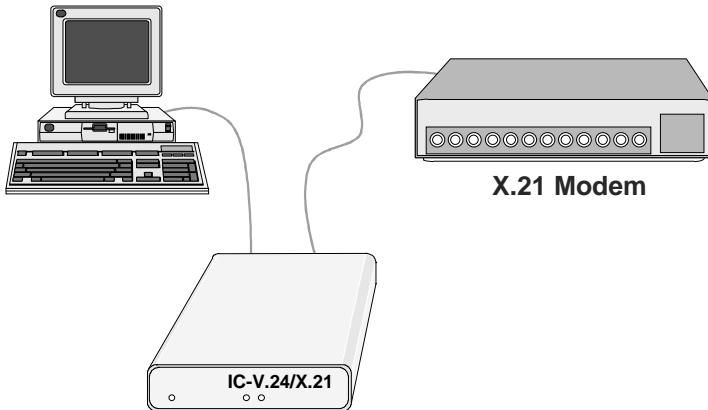

Typical Application

Note: Hazardous voltages are present when the equipment cover is removed. Installation and setup shall be performed by qualified service personnel only.

CHAPTER 2 - SETUP AND INSTALLATION

Installation

Set the switches to match the required configurations based on the diagrams below. The cabling between each device and the interface converter must be terminated with male connectors. J1 is the RS-232 / V.24 interface and J2 is the X.21 interface. The IEC connector is provided to interface to the power plug required in the country of use. Insure the 110/220VAC switch is set correctly for the line voltage in use prior to applying power to the interface converter.

Selection of DTE/DCE

To connect an RS-232 terminal type device (DTE) to an X.21 Modem type device (DCE), connect the terminal to J1 and the Modem to J2. Move SW1 and SW2 to the **DCE** position, and SW3, SW4 and SW5 to the **DTE** position, as shown in Fig. 1.

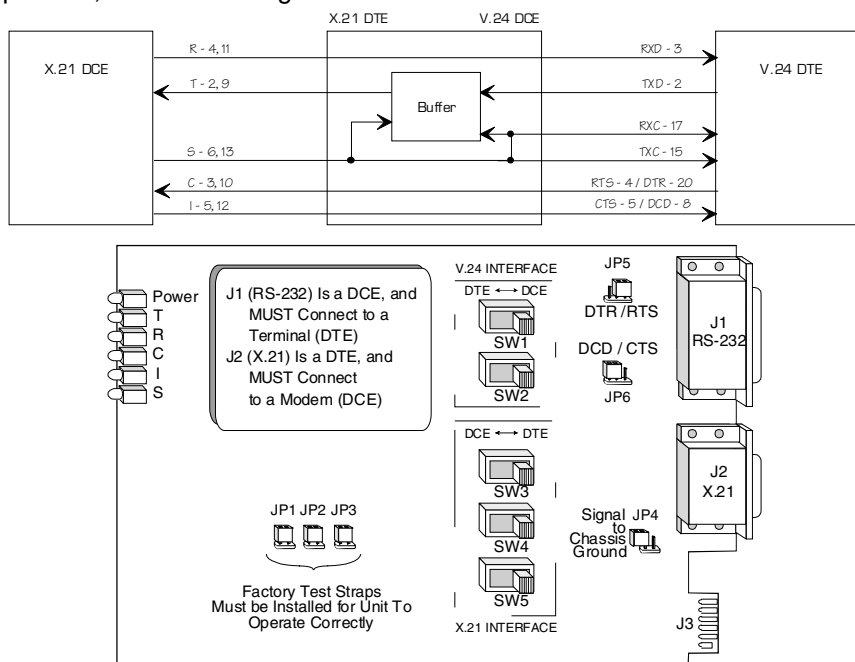

Figure 1.

*NOTE: All clocks in the communication system must be frequency locked. One and only one clock must be selected as master for the system. All other clocks must be

slaved to this clock.

To connect a X.21 terminal type device (DTE) to an RS-232 Modem type device (DCE), connect the terminal to J2 and the Modem to J1. Move SW1 and SW2 to the **DTE** position, and SW3, SW4 and SW5 to the **DCE** position, as shown in Fig.2.

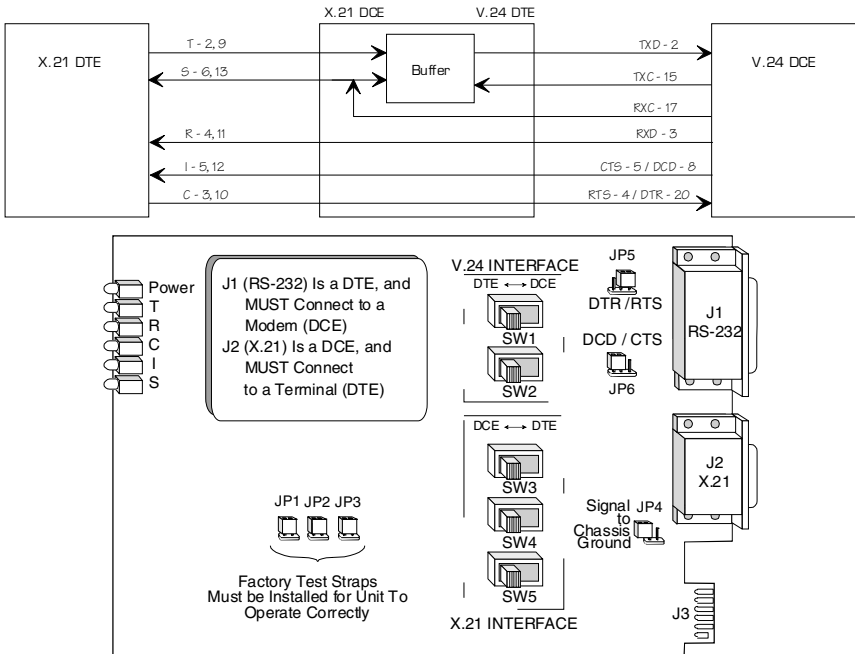
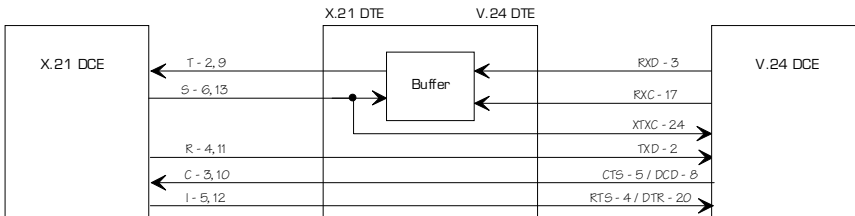

Figure 2.

To connect a X.21 Modem type device (DCE) to an RS-232 Modem type device (DCE), connect the X.21 Modem to J2 and the V.24 Modem to J1. Move SW1, SW2, SW3, SW4 and SW5 to the **DTE** position, as shown in Fig.3.



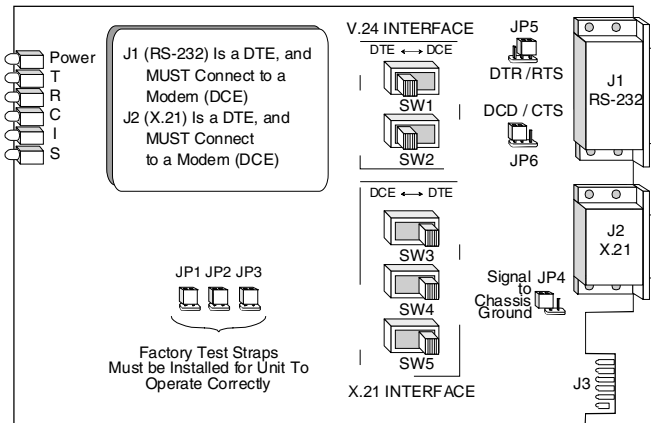

Figure 3 (Factory Default Setting)

Equipment Grounding

JP4 provides grounding interconnection in those systems requiring a connection between Frame Ground and Signal Ground. If signal ground and chassis ground interconnection is desired, install the jumper on JP4.

LED Indicators

The Following LED indicators are provided for diagnostics: Power, Transmit Data (T), Receive Data (R), Control (C), Indicate (I) and Signal Timing (S).

Factory Test Straps

The Factory Test Straps JP1, JP2 and JP3 must be installed for proper operation of the interface converter.

Signal Crossover

JP5 controls selection of DTR or RTS as the active V.24 control signal. JP6 controls selection of the DCD or CTS as the active V.24 control signal. The selection of DTE or DCE on the two interfaces will determine which X.21 signal is connected to which V.24 control signal.

APPENDIX

TECHNICAL SPECIFICATIONS

Applications

RS-232 to CCITT X.21 interface
conversion

Capacity

One RS-232 Channel
One CCITT X.21 Channel

Buffer

Bidirectional 8-bit ring buffer

Data Format

Transparent to Data

Data Rates

Up to 128Kbps

Electrical Interface

RS-232 and V.11

RS-232 Physical Interface

Female DB-25 (V.24) Connector

Balanced Physical Interface

Female DB-15 (V.11) Connector

DCE / DTE Configuration

Switch Selectable

Enclosure

Aluminum Shell or 1010R16/P/UI
(CTS MCS-16C) Card Rack
Assembly

Front Panel

Indicators: ... Power, Transmit
Data, Receive Data,
Control, Indicate,
Signal Timing

Power Requirements

110/220VAC, 50/ 60Hz, 0.16/
.08A, switch selectable Power
Supply

Environmental

Oper Temp: 32° to 122°F (0°
to 50°C)
Rel Humidity: ... Up to 90% non-
condensing
Altitude: 0 to 10,000 feet

Dimensions

Height: 2.00 inches (5.08cm)
Width: 8.80 inches (22.35cm)
Length: 9.80 inches (24.89cm)

Weight

2.25 lbs (1.02Kg)

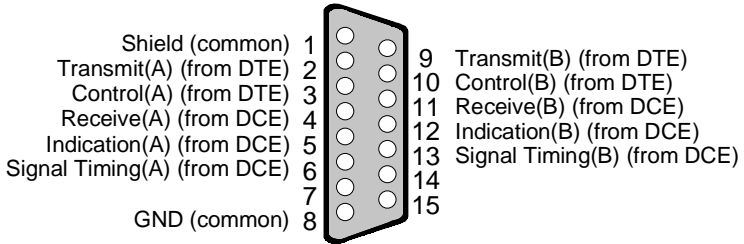

X.21 Interface Pins Supported

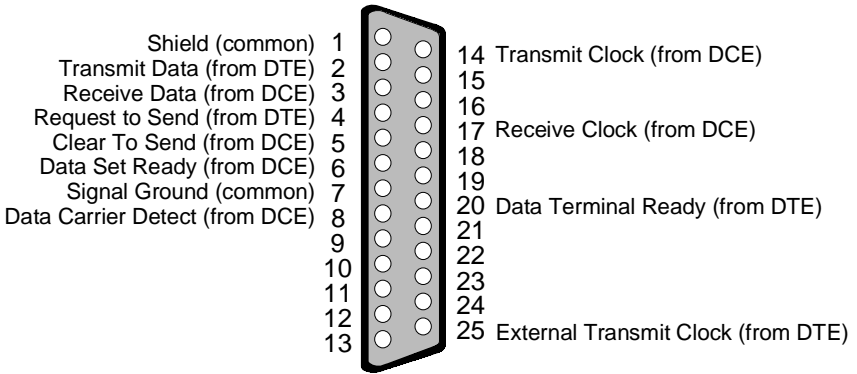

V.24 Interface Pins Supported



7622 Rickenbacker Drive
Gaithersburg, MD 20879

Sales: 301 975-1000 Support: 301 975-1007
Web Address: <http://www.patton.com>