

USER MANUAL

MODEL 2042 Series RS-530 to HSSI Interface Converter



Copyright © 2006
Patton Electronics Company
All Rights Reserved



An ISO-9001
Certified Company

Part# 07M2042-UM
Doc# 07722U2-001,
Rev. D
Revised 10/25/06

PATTON
Electronics Co.

SALES OFFICE
(301) 975-1000
TECHNICAL SUPPORT
(301) 975-1007
<http://www.patton.com>

TABLE OF CONTENTS

SECTION	PAGE
1.0 Warranty Information	2
1.1 Radio and TV Interference	
1.2 CE Notice	
1.3 Service Information	
2.0 General Information	4
2.1 Features	
2.2 Description	
3.0 Configuration	5
3.1 Configuration Switches (Model 2042MC-MT)	
3.2 Configuration Switches (Model 2042MT-MC)	
4.0 Installation.....	10
4.1 2042MC-MT Connection	
4.2 2042MT-MC Connection	
4.3 AC Power Connection	
4.4 DC Power Connection	
5.0 Operation	12
5.1 Back Panel LED Status Monitors	
5.2 Test Modes	
5.2.1 Local Loopback (LL)	
5.2.2 Remote Digital Loopback (RL)	
Appendix A - Specification	15
Appendix B - Factory Replacement Parts and Accessories	16
Appendix C - Interface Pin Assignments	17
Appendix D - 2042MT-MC Block Diagram.....	19
Appendix E - 2042MC-MT Block Diagram.....	20

1.0 WARRANTY INFORMATION

Patton Electronics warrants all Model 2042 components to be free from defects, and will—at our option—repair or replace the product should it fail within one year from the first date of shipment.

This warranty is limited to defects in workmanship or materials, and does not cover customer damage, abuse or unauthorized modification. If this product fails or does not perform as warranted, your sole recourse shall be repair or replacement as described above. Under no condition shall **Patton Electronics** be liable for any damages incurred by the use of this product. These damages include, but are not limited to, the following: lost profits, lost savings and incidental or consequential damages arising from the use of or inability to use this product.

Patton Electronics specifically disclaims all other warranties, expressed or implied, and the installation or use of this product shall be deemed an acceptance of these terms by the user.

1.1 RADIO AND TV INTERFERENCE

The Model 2042 generates and uses radio frequency energy, and if not installed and used properly—that is, in strict accordance with the manufacturer's instructions—may cause interference to radio and television reception. The Model 2042 has been tested and found to comply with the limits for a Class A computing device in accordance with the specifications in Subpart J of Part 15 of FCC rules, which are designed to provide reasonable protection from such interference in a commercial installation. However, there is no guarantee that interference will not occur in a particular installation. If the Model 2042 does cause interference to radio or television reception, which can be determined by disconnecting the Model 2042, the user is encouraged to try to correct the interference by one or more of the following measures: moving the computing equipment away from the receiver, re-orienting the receiving antenna and/or plugging the receiving equipment into a different AC outlet (such that the computing equipment and receiver are on different branches). This device must accept any interference received, including interference that may cause undesired operation.

1.2 CE NOTICE

The CE symbol on your Patton Electronics equipment indicates that it is in compliance with the Electromagnetic Compatibility (EMC) directive and the Low Voltage Directive (LVD) of the Union European (EU). A Certificate of Compliance is available by contacting Technical Support.

<p>WARNING: To Users of Digital Apparatus in Canada: This Class A digital apparatus meets all requirements of the Canadian interference-causing equipment regulations.</p>

1.3 SERVICE

All warranty and nonwarranty repairs must be returned freight pre-paid and insured to Patton Electronics. All returns must have a Return Materials Authorization number on the outside of the shipping container. This number may be obtained from Patton Electronics Technical Service at:

Tel: **(301) 975-1007**
Email: **support@patton.com**
www: **http://www.patton.com**

NOTE: Packages received without an RMA number will not be accepted.

Patton Electronics' technical staff is also available to answer any questions that might arise concerning the installation or use of your Model 2042. Technical Service hours: **8AM to 5PM EST, Monday through Friday.**

2.0 GENERAL INFORMATION

Thank you for your purchase of this Patton Electronics product. It has been thoroughly inspected and tested and is warranted for One Year for parts and labor. If you have any questions about this product, please call Patton Electronics Technical Support at (301) 975-1007.

2.1 FEATURES

- Bi-directionally converts RS-530 to HSSI.
- Supports synchronous data rates up to 10Mbps.
- Transparent to synchronous protocol.
- DB-25 and HD-50 connectors with integral 6-foot (1.8m) cable.
- Two versions available:
Model 2042MC-MT: Connects RS-530 (DTE) to HSSI (DCE)
Model 2042MT-MC: Connects 530 (DCE) to HSSI (DTE)
- Internal synchronization circuit enables high speed connections
- Externally AC powered.
- Made in the U.S.A.

2.2 DESCRIPTION

The Model 2042 is a RS-530 to High Speed Serial Interface (HSSI) converter. It allows a HSSI (HD-50) device to communicate bi-directionally with a RS-530 device at synchronous data rates up to 10Mbps. The Model 2042 supports all HSSI co-directional timing patterns, 2 loopback modes (local and remote line), full duplex data and control signals.

The Model 2042 is available in several versions: The Model 2042MT-MC lets a RS-530 DCE device communicate with a HSSI DTE device. The Model 2042MC-MT lets a RS-530 DTE device communicate with a HSSI DCE device.

All versions are equipped with a male DB-25 connector on the converter end, and a male HD-50 on the end of a 6-foot (1.8 m) cable. Other connector genders and cable lengths are available on a custom basis. Power is supplied to the Model 2042 by an external desktop AC transformer.

3.0 CONFIGURATION

The Model 2042 is easy to install and is ruggedly designed for excellent reliability. The following instructions will help you set up and install the Model 2042 properly.

To use the Patton Model 2042, you must first configure the unit for your application. To do so, first open the case by inserting a flat head screw driver into an open slot on either side of the case, as in Figure 1.

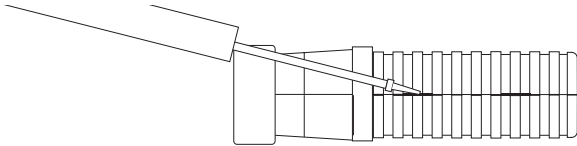

Figure 1: Using a Small Screw Driver to Open the Model 2042 Case

Twist the screw driver head slightly and the top half of the case will separate from the lower half, as in Figure 2. You now have access to the internal switches used to configure the unit.

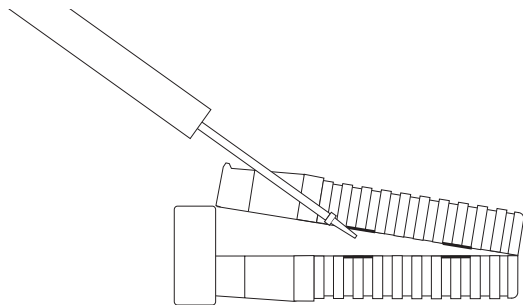

Figure 2: Using a Small Screw Driver to Open the Model 2042 Case

After opening the case, please refer to the section that pertains to your unit for configuration details:

<u>Patton Model Number</u>	<u>Section</u>
Model 2042MC-MT.....	3.1
Model 2042MT-MC.....	3.2

To close the case, fit the 2 halves together snugly and snap them back in place.

3.1 CONFIGURATION SWITCHES (MODEL 2042MC-MT)

The Model 2042MC-MT has miniature DIP switches that you may use to configure the units. Each Model 2042MC-MT is factory configured as DCE on the RS-530 end, and DTE on the HSSI end. Therefore, the RS-530 end “wants” to plug directly into a DTE device. Conversely, the HSSI end of the converter “wants” to plug directly into DCE.

Please use this section to configure the internal DIP switches so that the unit will work properly in your application. Figure 3 shows the position of the DIP switches on the top side of the PC board.

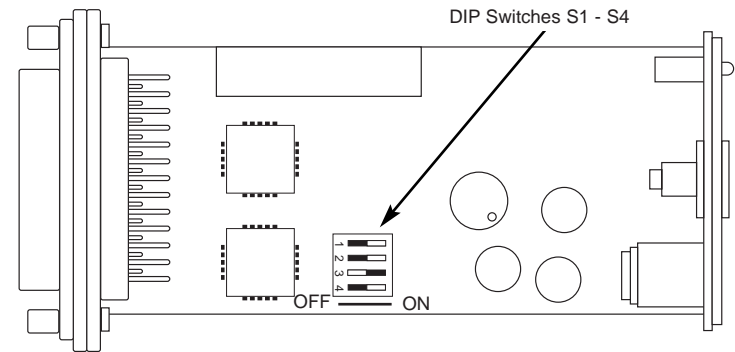

Figure 3. The Model 2042MC-MT Assembly Drawing

Figure 4 shows the orientation of the switches on DIP Switches S1 through S4 with respect to ON/OFF positions. The default settings for DIP Switch S1 are shown in the table 1 on page 6. Detailed descriptions of each switch follow the table.

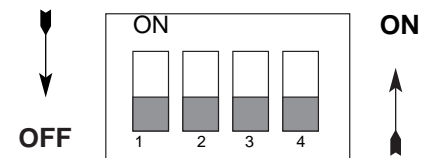

Figure 4. Close-up of DIP Switches Showing “ON” and “OFF” Positions

2042MC-MT DIP SWITCH SUMMARY TABLE		
Position	Function	Factory Default
S1	Clock Source	On
S2	Clock Source	Off
S3	Sync Method	Off
S4	Sync Method	On

Switches S1 and S2: Clock Source

The setting for Switches S1 and S2 determines the source of the HSSI Terminal Timing (TT) for the 2042MC-MT. With Switch S1 On and S2 Off, the Model 2042MC-MT derives the HSSI Terminal Timing from the ST signal provided by the HSSI DCE. With Switch S1 Off, and S2 On, the RS-530 DTE provides TT to the HSSI DCE.

S1	S2	Description
Off	Off	Not a Valid Setting
Off	On	Terminal Timing Supplied by RS-530 DTE device
On	Off	Terminal Timing supplied by HSSI ST signal
On	On	Not a Valid Setting

Switches S3 and S4: Synchronization Method

Switches S3 and S4 allow the Model 2042MC-MT to compensate for timing delays when transmitting HSSI data at high speeds (greater than 2.5 Mbps). At high bit rates, set Switch S3 On and Switch S4 Off. In this setting, the RS-530 data will be synchronized to the SD timing signal before conversion to HSSI. At lower bit rates (less than 2.5 Mbps), set Switch S3 Off and S4 On. In this setting, the RS-530 data bypasses the synchronization circuit and is passed straight through to the HSSI DCE.

S3	S-4	Description
Off	Off	Not a Valid Setting
Off	On	Data Skips Sync Circuit
On	Off	Data passes through sync circuit.
On	On	Not a Valid Setting

3.2 CONFIGURATION SWITCHES (MODEL 2042MT-MC)

The Model 2042MT-MC has miniature DIP switches that you may use to configure the units. Each Model 2042MT-MC is factory configured as DTE on the RS-530 end, and DCE on the HSSI end. Therefore, the RS-530 end “wants” to plug directly into a DCE device. Conversely, the HSSI end of the converter “wants” to plug directly into DTE.

Please use this section to configure the internal DIP switches so that the unit will work properly in your application. Figure 5 shows the position of the DIP switches on the top side of the PC board.

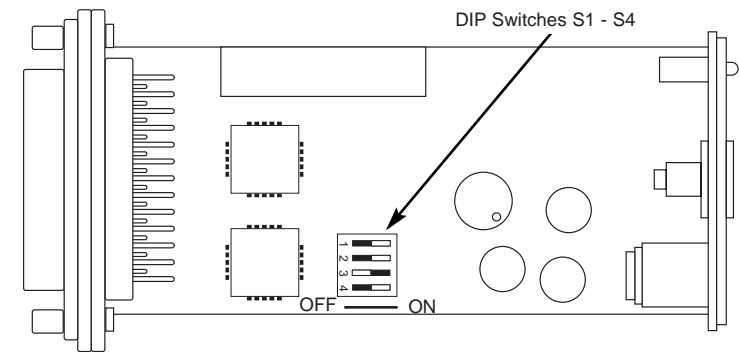

Figure 5. The Model 2042MT-MC Assembly Drawing

Figure 6 shows the orientation of the Switches on DIP Switches S1 through S4 with respect to ON/OFF positions. The default settings for DIP switch S1 are shown in the table on page . Detailed descriptions of each switch follow the table.

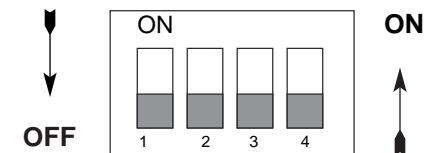

Figure 6. Close-up of DIP Switches Showing “ON” and “OFF” Positions

2042MT-MC DIP SWITCH SUMMARY TABLE		
Position	Function	Factory Default
S1	Gapped Clock	On
S2	Gapped Clock	Off
S3	Sync Method	Off
S4	Sync Method	On

Switches S1 and S2: Gapped Clock

Switches S1 and S2 allow the Model 2042MT-MC to generate a HSSI gapped clock. Gapped clocking is a method of flow control in which data flow is interrupted by an idle (gapped) clock signal. In this mode, the Model 2042MT-MC will gap the ST clock to the HSSI DTE whenever the RS-530 CTS signal is de-asserted. In the 'No Gapped Clock' setting, the RS-530 clock passes through with only a level change.

S1	S2	Description
Off	Off	Not a Valid Setting
Off	On	Gapped Clock
On	Off	No Gapped Clock
On	On	Not a Valid Setting

Switches S3 and S4: Synchronization Method

Switches S3 and S4 allow the Model 2042MT-MC to compensate for timing delays when transmitting HSSI data at high speeds (greater than 2.5 Mbps). At high bit rates, set Switch S3 On and Switch S4 Off. In this setting, the HSSI SD signal will be synchronized to the SD timing signal before conversion to RS-530. At lower bit rates (less than 2.5 Mbps), set Switch S3 Off and S4 On. In this setting, the RS-530 data bypasses the synchronization circuit and is passed straight through to the HSSI DTE.

S3	S4	Description
Off	Off	Not a Valid Setting
Off	On	Data Skips Sync Circuit
On	Off	Data passes through sync circuit.
On	On	Not a Valid Setting

4.0 INSTALLATION

The Model 2042 is designed to connect RS-530 devices to devices which employ the HSSI interface standard. This section describes how to install the units.

4.1 2042MC-MT CONNECTION

The Model 2042MC-MT is designed to connect an RS-530 DTE device to an HSSI DCE device. In this application, the DB-25 (RS-530) and HD-50 (HSSI) male connectors of the Model 2042MC-MT may connect directly to their respective equipment ports, or they may connect via a short "straight-through" cable (See Appendix C for Interface Pin Assignments). Figure 7 below illustrates the proper connection of the Model 2042MC-MT.

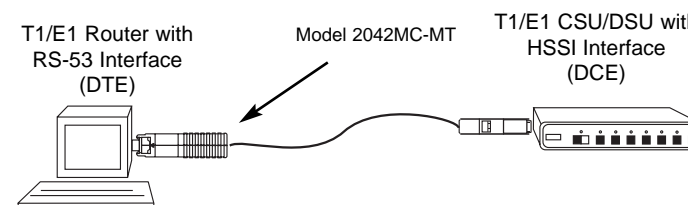

Figure 7. A Common RS-530 DTE to HSSI DCE Installation

4.2 2042MT-MC CONNECTION

The Model 2042MT-MC is designed to connect an RS-530 DCE device to an HSSI DTE device. In this application, the DB-25 (RS-530) and HD-50 (HSSI) male connectors of the Model 2042MT-MC may connect directly to their respective equipment ports, or they may connect via a short "straight-through" cable (See Appendix C for Interface Pin Assignments). Figure 8 below illustrates the proper connection of the Model 2042MT-MC.



Figure 8. A Common HSSI DTE to RS-530 DCE Installation

4.3 AC POWER CONNECTION

The Model 2042 uses a 5VDC, 2A universal input, power supply that is equipped with a male IEC-320 power entry connector and supports a voltage range of 100-240VAC. This transformer connects to the Model 2042 by means of a cannon jack on the rear panel. There are a variety of domestic and international power cords available for the power entry (See Appendix B). The Model 2042 is powered-up as soon as it is plugged into an AC outlet—there is no power switch.

4.4 DC POWER CONNECTION

The 36-60 VDC DC to DC adapter is supplied with the DC version of the Model 2042. The black and red leads plug into a DC source (nominal 48VDC) and the barrel power connector plugs into the barrel power supply jack on the 2042.



5.0 OPERATION

Once you have configured the Model 2042 properly (see Section 3.0) and have correctly connected DTE, DCE and power (see Section 4.0), you are ready to operate the unit. This section describes the LED status monitors and loopback test modes.

5.1 BACK PANEL LED STATUS MONITORS

The Model 2042 features two LEDs that are located on the back panel. Figure 9 below shows the positions of the LEDs. Following Figure 9 is a description of each LED.

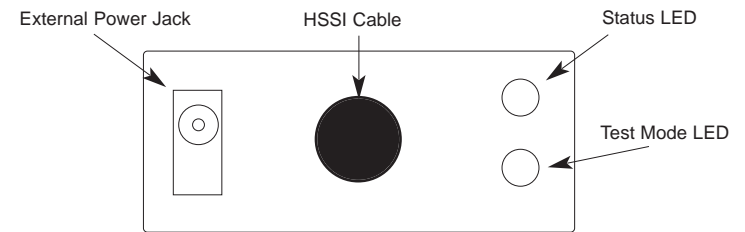

Figure 9. Model 2042 Rear Panel

Status Glows green to indicate that both DTR (from the DTE device) and DSR (from the DCE device) are active. This LED will not be illuminated whenever one of the two signals are inactive.

Test Mode Glows green to indicate that either one or both of the test modes are active (See Section 5.2 for a description of the test modes).

5.2 TEST MODES

The Model 2042 supports two loopback modes that may be used to evaluate the condition of the communication links. These modes, (Local Loopback (LL) and Remote Loopback (RL), are always **initiated by the signals on the DTE device** (See Figure 10). This section describes both loopback modes.

NOTE: HSSI supports a third loopback mode: Local Digital Loopback (LDL). However, RS-530 does not support this mode. In order to use LDL, the RS-530 device must be programmed to respond according to the HSSI specification for LDL (See TIA/EIA-613, Section 6.2.1 Local Digital Loopback (Loop A).

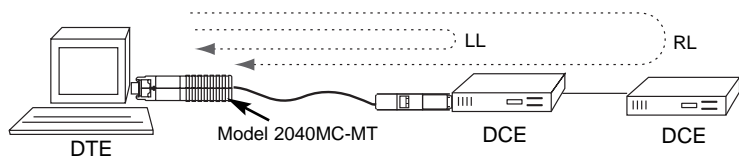

Figure 10. Local Loopback and Remote Loopback Modes

5.2.1 Local Loopback (LL)

The Local Loopback (LL) test checks the performance of the link between the DTE device and the DCE. Any data sent to the Model 2042 from the DTE in this test mode will be sent to the local DCE and will then be echoed (returned) back to the DTE (the Model 2042 simply converts and passes the data to the local DCE, which must perform the loopback). To perform a LL test, follow these steps:

- A. Verify that the data terminal equipment is operating properly and can be used for a test. If a fault is indicated, call a technician or replace the unit.
- B. Activate LL from the DTE device. This may be done either by raising pin L (if the RS-530 device is DTE), or by activating Local Loopback from the HSSI Interface (if the HSSI device is the DTE). The “test” LED should be lit.
- C. Perform a BER (bit error rate) test from the DTE. If the test indicates no fault, deactivate LL and proceed as normal.

5.2.2 Remote Digital Loopback (RL)

The Remote Loopback (RL) test checks the performance of the link between the DTE device and the DCE as well as the link between the local and remote DCE devices. Any characters sent from the DTE in this test mode will be sent to the local DCE, which will send the data to the remote DCE. The remote DCE should return the data back through the entire communication link and finally, to the DTE. To perform a RL test, follow these steps:

- A. Activate RL from the DTE device. This may be done either by raising pin N on the RS-530 interface (if the RS-530 device is DTE), or by activating Local Loopback from the HSSI interface (if the HSSI device is the DTE). The “test” LED should be lit.
- B. Perform a BER (bit error rate) test from the DTE.
- C. If the BER test equipment indicates a fault, and the Local Loopback test was successful, you may have a problem with the cable between the DCE devices.

NOTE: The Model 2042 simply converts and passes the data through the communication link. The DCEs must be configured to perform to the appropriate loopback diagnostic.

APPENDIX A

PATTON ELECTRONICS MODEL 2042 SPECIFICATIONS

Data Format:	Synchronous
Data Rate:	0 - 10Mbps
Clocking:	All HSSI co-directional timing patterns are supported.
Standards:	Converts EIA/TIA-530 to HSSI (ANSI/TIA/EIA-613 Dec. '93 and ANSI/TIA/EIA-612 NOV. '93) electrical-ly and mechanically;
Loopbacks:	Local and Remote
Interfaces:	Model 2042MC-MT: Connects RS-530 (DTE) to HSSI (DCE) Model 2042MT-MC: Connects RS-530 (DCE) to HSSI (DTE)
Cable:	6 feet (1.8 m)
Connectors:	Male HD/Slimline 50-pin (HSSI); Male DB-25 (RS-530)
Compliance:	FCC Class A, IEC CE (emissions).
Power:	Unit will require an external desk top power supply.
Temperature Range:	0 to 50° C (32 - 122°F)
Humidity:	5 to 95%, non-condensing
Size:	3.0"L x 1.8"W x 0.8"H (7.6 X 4.4 X 1.9 CM)
Approval:	CE (EMC Directive/EN 50082-1)

APPENDIX B

PATTON ELECTRONICS MODEL 2042 FACTORY REPLACEMENT PARTS AND ACCESSORIES

<u>Patton Model #</u>	<u>Description</u>
08055DCUI.....	100-240VAC (+5V ±5% reg. DC/2A) Universal Input Adapter
0805EUR.....	European Power Cord CEE 7
0805UK	United Kingdom Power Cord
0805US	American Power Cord
0805AUS	Australia/New Zealand Power Cord
0805DEN.....	Denmark Power Cord
0805FR.....	France/Belgium Power Cord
0805IN.....	India Power Cord
0805IS	Israel Power Cord
0805JAP.....	Japan Power Cord
0805SW.....	Switzerland Power Cord
07M2042-B.....	User Manual

APPENDIX C

PATTON ELECTRONICS MODEL 2042

HSSI INTERFACE
HD-50 Connector (DCE or DTE)

<u>Pin #</u>	<u>Signal</u>
1	SGND (Signal Ground)
26	SGND (Signal Ground)
2	RT (Receive Timing-A)
27	RT/ (Receive Timing-B)
3	DSR/(DCE Ready-A)
28	DSR (DCE Ready-B)
4	RD (Receive Data-A)
29	RD/ (Receive Data-B)
5	<i>Reserved for Future Use</i>
30	<i>Reserved for Future Use</i>
6	ST (Send Timing - A, DCE Source)
31	ST/ (Send Timing-B, DCE Source)
7	<i>Reserved for Future Use</i>
32	<i>Reserved for Future Use</i>
8	DTR (DTE Ready-A)
33	DTR/ (DTE Ready-B)
9	TT (Terminal Timing-A, DTE Source)
34	TT/ (Terminal Timing-B, DTE Source)
10	LA (Loopback A-A)
35	LA/ (Loopback A-B)
11	SD (Send Data A)
36	SD/ (Send Data B)
12	LB (Loopback B-A)
37	LB/ (Loopback B-B)
13	<i>Reserved for Future Use</i>
38	<i>Reserved for Future Use</i>
14 - 18	<i>Reserved for Future Use</i>
39 - 43	<i>Reserved for Future Use</i>
19	<i>Reserved for Future Use</i>
44	<i>Reserved for Future Use</i>
20 - 23	<i>Reserved for Future Use</i>
45 - 48	<i>Reserved for Future Use</i>
24	TM - Test Mode (Indication-A)
49	TM/ - Test Mode (Indication-B)
25	SGND (Signal Ground)
50	SGND (Signal Ground)

APPENDIX C

PATTON ELECTRONICS MODEL 2042

RS-530 INTERFACE
DB-25 Connector

<u>Pin #</u>	<u>Signal</u>
1	FG (Frame Ground)
2	TD (Transmit Data)
3	RD (Receive Data)
4	RTS (Request to Send)
5	CTS (Clear to Send)
6	DSR (Data Set Ready)
7	SGND (Signal Ground)
8	CD (Carrier Detect)
9	RC/ (Receive Timing-B)
10	CD/ (Carrier Detect-B)
11	XTC/ (External Transmit Clock)
12	TC/ (Test Control-B)
13	CTS/ (Clear to Send)
14	TD/ (Transmit Data-B)
15	TC (Test Control-A)
16	RD (Receive Data)
17	RC (Receive Timing)
18	LLB (Local Line Loop)
19	RTS/ (Request to Send)
20	DTR (Data Transfer Rate)
21	DL (Remote Digital Loop)
22	DSR/ (Data Set Ready)
23	DTR/ (Data Transfer Rate)
24	XTC (External Transmit Clock)
25	TM (Test Mode)

APPENDIX D

PATTON ELECTRONICS MODEL 2042MT-MC
BLOCK DIAGRAM

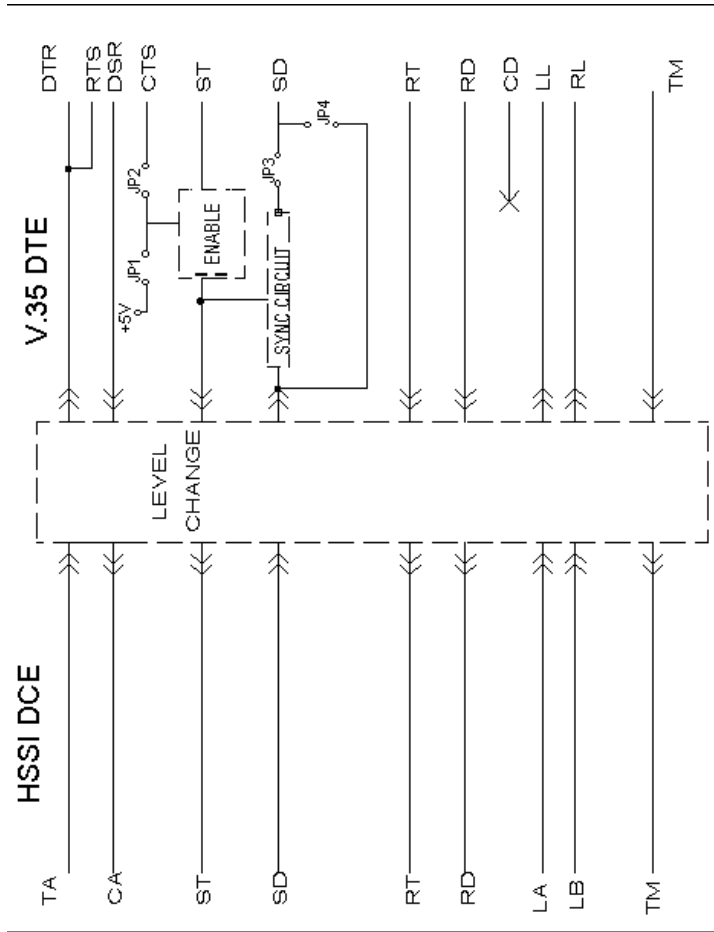

APPENDIX E

PATTON ELECTRONICS MODEL 2042MC-MT
BLOCK DIAGRAM

