

USER MANUAL

MODELS 2113 & 2115 CopperLink™-T T1/E1 Extenders



Important — This is a Class A device and is intended for use in a light industrial environment. It is not intended nor approved for use in an industrial or residential environment.

PA **PATTON**
IE **Electronics Co.**



Part# 07M2113-UM
Doc# 03331U2-001,
Rev. B
Revised 8/16/07

SALES OFFICE
(301) 975-1000
TECHNICAL SUPPORT
(301) 975-1007

An ISO-9001 Certified
Company

CONTENTS

1.0	Warranty Information	3
1.1	Radio and TV Interference.....	3
1.2	CE Declaration of Conformity	3
1.3	Authorized European Representative.....	4
1.4	FCC Part 68.....	4
1.5	Industry Canada Notice	4
1.6	Compliance.....	6
	EMC.....	6
	Safety	6
	PSTN Regulatory.....	6
1.7	Service.....	6
	Alternate Patton support for Europe, Middle East, and Africa (EMEA).....	7
1.8	Safety When Working With Electricity	7
2.0	General Information.....	8
2.1	Features.....	8
2.2	Description.....	8
3.0	Installation.....	9
3.1	Connecting Power	10
3.2	Power Input Connector	10
	External AC universal power supply.....	10
3.3	Connecting the Line Port	11
3.4	Connecting the Circuit Interface	11
4.0	Operation.....	13
4.1	Front Panel LED Status Monitors	13
4.2	Configuration and Dip Switches.....	14
	Switch S1-7: Line Build Out.....	14
A		
	Specifications	15
A.1	Circuit Rates	15
A.2	Circuit Interface	15
A.3	Circuit Defaults	15
A.4	Circuit Connector	15
A.5	LED Indicators	15
A.6	Power and Power Supply Specifications	15
A.7	Environmental	16
A.8	Transmission Line	16
A.9	Line Coding	16
A.10	Line Interface	16
A.11	Line Physical Connection	16
B		
	Factory Default Dip Switch Configuration.....	17
B.1	Switch S1 - Factory Default configuration	17
B.2	Switch S2 - Factory Default configuration	17

1.0 WARRANTY INFORMATION

Patton Electronics warrants all Model 2113 or 2115 components to be free from defects, and will—at our option—repair or replace the product should it fail within one year from the first date of the shipment.

This warranty is limited to defects in workmanship or materials, and does not cover customer damage, abuse or unauthorized modification. If this product fails or does not perform as warranted, your sole recourse shall be repair or replacement as described above. Under no condition shall **Patton Electronics** be liable for any damages incurred by the use of this product. These damages include, but are not limited to, the following: lost profits, lost savings and incidental or consequential damages arising from the use of or inability to use this product. **Patton Electronics** specifically disclaims all other warranties, expressed or implied, and the installation or use of this product shall be deemed an acceptance of these terms by the user.

Note Conformity documents of all Patton products can be viewed online at www.patton.com under the appropriate product page.

1.1 RADIO AND TV INTERFERENCE

This equipment generates and uses radio frequency energy, and if not installed and used properly—that is, in strict accordance with the manufacturer's instructions—may cause interference to radio and television reception. This equipment has been tested and found to comply with the limits for a Class A computing device in accordance with the specifications in Subpart B of Part 15 of FCC rules, which are designed to provide reasonable protection from such interference in a commercial installation. However, there is no guarantee that interference will not occur in a particular installation. If the equipment causes interference to radio or television reception, which can be determined by disconnecting the cables, try to correct the interference by one or more of the following measures: moving the computing equipment away from the receiver, re-orienting the receiving antenna, and/or plugging the receiving equipment into a different AC outlet (such that the computing equipment and receiver are on different branches).

1.2 CE DECLARATION OF CONFORMITY

We certify that the apparatus identified in this document conforms to the requirements of Council Directive 1999/5/EC on the approximation of the laws of the member states relating to Radio and Telecommunication Terminal Equipment and the mutual recognition of their conformity.

The safety advice in the documentation accompanying this product shall be obeyed. The conformity to the above directive is indicated by the CE sign on the device.

1.3 AUTHORIZED EUROPEAN REPRESENTATIVE

D R M Green, European Compliance Services Limited.
Oakdene House, Oak Road , Watchfield, Swindon, Wilts SN6 8TD, UK

1.4 FCC PART 68

This equipment complies with Part 68 of FCC rules and the requirements adopted by ACTA. On the bottom side of this equipment is a label that contains—among other information—a product identifier in the format *US: AAAEQ##TXXXX*. If requested, this number must be provided to the telephone company.

The method used to connect this equipment to the premises wiring and telephone network must comply with the applicable FCC Part 68 rules and requirements adopted by the ACTA.

If this equipment causes harm to the telephone network, the telephone company will notify you in advance that temporary discontinuance of service may be required. But if advance notice isn't practical, the telephone company will notify the customer as soon as possible. Also, you will be advised of your right to file a complaint with the FCC if you believe it is necessary.

The telephone company may make changes in its facilities, equipment, operations or procedures that could affect the operation of the equipment. If this happens the telephone company will provide advance notice in order for you to make necessary modifications to maintain uninterrupted service.

If trouble is experienced with this equipment, for repair or warranty information, please contact our company. If the equipment is causing harm to the telephone network, the telephone company may request that you disconnect the equipment until the problem is resolved.

Connection to party line service is subject to state tariffs. Contact the state public utility commission, public service commission or corporation commission for information.

1.5 INDUSTRY CANADA NOTICE

This equipment meets the applicable Industry Canada Terminal Equipment Technical Specifications. This is confirmed by the registration number. The abbreviation, IC, before the registration number signifies that

registration was performed based on a Declaration of Conformity indicating that Industry Canada technical specifications were met. It does not imply that Industry Canada approved the equipment.

This Declaration of Conformity means that the equipment meets certain telecommunications network protective, operational and safety requirements. The Department does not guarantee the equipment will operate to the user's satisfaction. Before installing this equipment, users should ensure that it is permissible to be connected to the facilities of the local telecommunications company. The equipment must also be installed using an acceptable method of connection. In some cases, the company's inside wiring associated with a single line individual service may be extended by means of a certified connector assembly (telephone extension cord). The customer should be aware that compliance with the above condition may not prevent degradation of service in some situations. Repairs to some certified equipment should be made by an authorized maintenance facility designated by the supplier. Any repairs or alterations made by the user to this equipment, or equipment malfunctions, may give the telecommunications company cause to request the user to disconnect the equipment. Users should ensure for their own protection that the ground connections of the power utility, telephone lines and internal metallic water pipe system, are connected together. This protection may be particularly important in rural areas.

1.6 COMPLIANCE

EMC

- FCC Part 15, Class A
- EN55022, Class A
- EN55024

Safety

- UL 60950-1/CSA C22.2 N0. 60950-1
- IEC/EN60950-1
- AS/NZS 60950-1

PSTN Regulatory

- FCC Part 68
- CS03
- TBR12 & 13
- AS/ACIF S016:2001
- AS/ACIF S043:2003

1.7 SERVICE

All warranty and non-warranty repairs must be returned freight prepaid and insured to Patton Electronics. All returns must have a Return Materials Authorization number on the outside of the shipping container. This number may be obtained from Patton Electronics Technical Services at:

- Telephone: **+1 (301) 975-1007**
- Email: **support@patton.com**
- URL: **http://www.patton.com**

Technical support is available from **8 AM to 5 PM EST (8:00 to 17:00 UTC-5), Monday through Friday.**

Note Packages received without an RMA number will not be accepted.

Alternate Patton support for Europe, Middle East, and Africa (EMEA)

- Telephone support: Standard telephone support is available five days a week—from **8:00 am to 5:00 pm CET (0900 to 1800 UTC/GMT)**—by calling **+41 (0)31 985 25 55**
- Fax: **+41 (0)31 985 25 26**

1.8 SAFETY WHEN WORKING WITH ELECTRICITY



- This device contains no user serviceable parts. The equipment shall be returned to Patton Electronics for repairs, or repaired by qualified service personnel.

- The external AC adaptor shall be a listed limited power source that incorporates a disconnect device and shall be positioned within easy reach of the operator. Ensure that the AC power cable meets all applicable standards for the country in which it is to be installed, and that it is connected to a wall outlet which has earth ground.

- Do not work on the system or connect or disconnect cables during periods of lightning activity.



In accordance with the requirements of council directive 2002/96/EC on Waste of Electrical and Electronic Equipment (WEEE), ensure that at end-of-life you separate this product from other waste and scrap and deliver to the WEEE collection system in your country for recycling.

2.0 GENERAL INFORMATION

Thank you purchasing this Patton Electronics product. This product has been thoroughly inspected and tested and is warranted for one year for parts and labor. If questions arise while installing or using this product, contact **Technical Support** at **+1 (301) 975-1007**.

2.1 FEATURES

- Easy-to-install T1/E1 Extenders—*no configuration required*
- Data rates up to 2.048 Mbps in 64-kbps intervals
- Plug 'n' Play for easy installations
- LED indicators for Power, Ethernet Link, and Frame
- CE marked

2.2 DESCRIPTION

The Patton Electronics Model 2113/2115 CopperLink™-T provides high speed 2-wire T1/E1 extension connectivity to ISPs, PTTs, and enterprise environments using binder group friendly TC-PAM modulation.

Line connection is made with an RJ-45 jack. Models 2113 and 2115 are powered by an 100/230 VAC (Universal) supply. The NTU features externally-accessible DIP switches, loopback diagnostics, and CopperLink™-T Plug 'n' Play.

3.0 INSTALLATION

Because the CopperLink-T T1/E1 Extenders require no configuration, they can be installed quickly. Installation consists of the following:

- Connect the power plug (refer to section 3.1, “Connecting Power” on page 10).
- Connect the line port (refer to section 3.3, “Connecting the Line Port” on page 11)

Note See Figure 1 and Figure 2 for the rear-panel connectors locations.

- Connect the T1/E1 port (refer to section 3.4, “Connecting the Circuit Interface” on page 11).

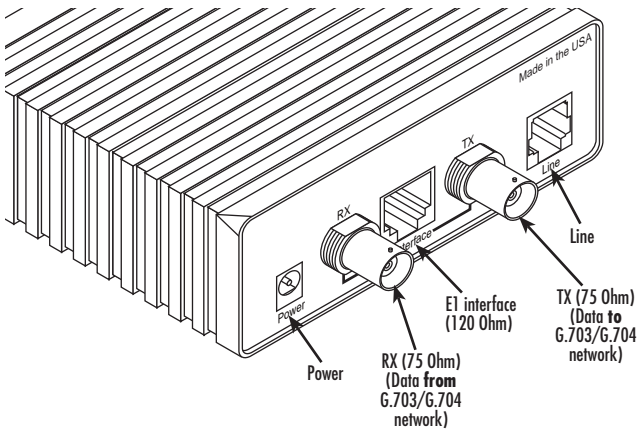

Figure 1. CopperLink-T Model 2113 rear panel

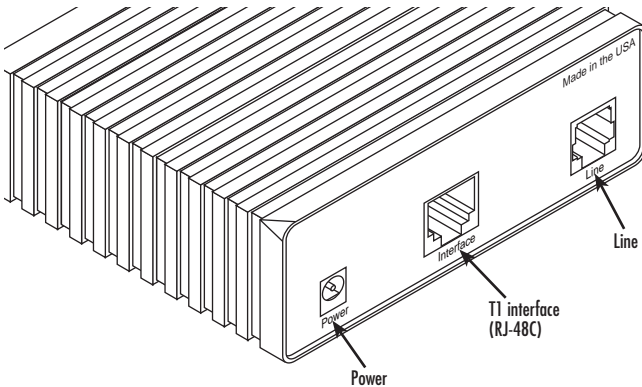

Figure 2. CopperLink-T Model 2115 rear panel

3.1 CONNECTING POWER



The external AC adaptor shall be a listed limited power source that incorporates a disconnect device and shall be positioned within easy reach of the operator. Ensure that the AC power cable meets all applicable standards for the country in which it is to be installed, and that it is connected to a wall outlet which has earth ground.

Your CopperLink-T T1/E1 Extender comes with an external AC adaptor with a detachable power cord.

To connect power to the CopperLink-T:

1. Connect the female plug of the AC power cord to the AC adaptor provided.
2. Connect the barrel-type connector of the AC adaptor to the Power connector on the CopperLink-T.
3. Insert the male plug of the AC power cord into the AC power outlet (100-240 VAC).
4. Verify that the Power LED on the front panel illuminates and remains lit.

3.2 POWER INPUT CONNECTOR

The CopperLink-T T1/E1 Extender comes with an AC power supply.

- The supplies connection to the CopperLink-T T1/E1 Extender is a 2.5 mm barrel receptacle with the center conductor positive (see Figure 3).

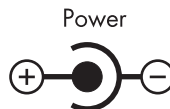

Figure 3. Power connection barrel receptacle diagram

- CopperLink-T T1/E1 Extender's rated voltage: 5.0 VDC
- CopperLink-T T1/E1 Extender's rated current: 1 A DC

External AC universal power supply

- Output from power supply: 5 VDC, 2A
- Input to power supply: universal input 100–240 VAC 50/60 Hz 0.3A



The interconnecting cables shall be acceptable for external use and shall be rated for the proper application with respect to voltage, current, anticipated temperature, flammability, and mechanical serviceability.

3.3 CONNECTING THE LINE PORT

Follow the steps below to connect the CopperLink-T line port:

1. Obtain a single-twisted pair cable with an RJ-45 plug connector at each end.
2. Plug one end of the cable into the RJ-45 socket (labeled Line) on the CopperLink-T .
3. When the remote and local extender units synchronize, the front-panel Link LED will turn on.

3.4 CONNECTING THE CIRCUIT INTERFACE

Your CopperLink-T comes with either an RJ-48C or an RJ-48C and dual BNC for connection to a T1 or E1:

- Model 2113 - E1: 120-Ohm RJ-48C and dual 75-Ohm BNC connectors
- Model 2115 - T1: RJ-48C

To connect the twisted pair cable to the CopperLink-T T1/E1 port:

1. Attach the male connector of the twisted pair cable to the female RJ-48 connector on the CopperLink-T.
2. Attach the other end of the cable to the RJ-48 connector on the local T1 or E1.

Note When attaching the 2113/2115 directly to a T1/E1 circuit, a straight through twisted pair cable can be used. When attaching the 2113/R or 2115/R to a device, please use the enclosed T1/E1 cross over cable for proper operation.

Note The unit marked as 2113/L or 2115/L is configured by default to accept timing from the T1/E1 circuit. The 2113/R or 2115/R unit then recovers this timing from the line in order to ensure synchronization of the T1/E1 circuit over the extenders.

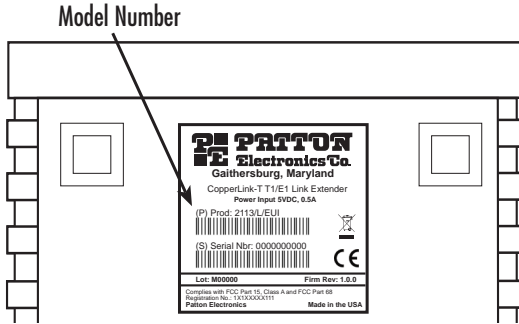

Figure 4. The label showing the specific model number on the bottom of the unit

4.0 OPERATION

Once the CopperLink-T T1/E1 Extenders are properly installed, they should operate transparently. No user settings required. This section describes reading the LED status monitors.

4.1 FRONT PANEL LED STATUS MONITORS

Models 2113 and 2115 feature three front-panel LEDs that monitor power, Ethernet signals, and the CopperLink connection. Figure 5 shows the front panel location of each LED. Table 1 describes the LED functions.

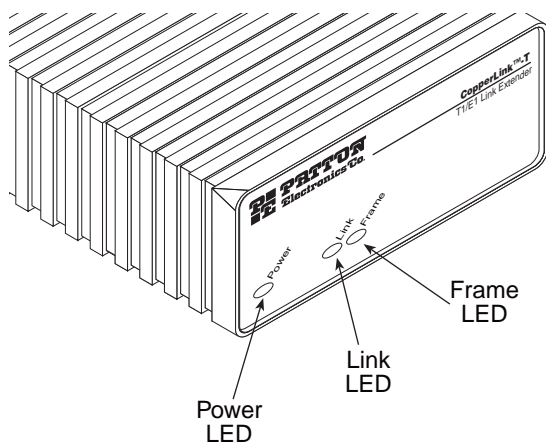

Figure 5. CopperLink-T T1/E1 Extender front panel

Table 1: Front panel LED description

LED	Description
Power	When lit, indicates the unit is powered on
Link	<ul style="list-style-type: none">• On solid—link is connected• Off—No signal detected• Flashing — Data is being transmitted/received
Frame	<ul style="list-style-type: none">• On solid—T1/E1 frame is connected• Off — No signal detected• Flashing — Error detected

4.2 CONFIGURATION AND DIP SWITCHES

The CopperLink-T™ T1/E1 Extenders are Plug 'n' Play enabled and do not require any configuration by the user.

Note The user **should NOT** change any of the dip switches except for S1-7 (if necessary). If the user changes the position of any of the dip switches (except for S1-7), it **will affect** the operation of the unit. Refer to Appendix B on page 17 for the factory default dip switch configuration.

Switch S1-7: Line Build Out

Switch S1-7 defines the shape of the waveform on the T1 or E1 line.

Table 2: S1-7 Default Position

Switch	2113/L/EUI	2113/R/EUI	2115/L/EUI	2115/R/EUI
S1-7	OFF (120)	OFF (120)	ON (0.0dB)	ON (0.0dB)

APPENDIX A

SPECIFICATIONS

A.1 CIRCUIT RATES

- **Model 2113** - 2.048 Mbps
- **Model 2115** - 1.544 Mbps

A.2 CIRCUIT INTERFACE

- E1 (Model 2113) presents G.703/G.704 interface. Either 75 Ohms (unbalanced) or 120 Ohms (balanced). Pins 1 & 2 are Receive. Pins 4 & 5 are transmit.
- T1 (Model 2115) present T1 interface. Pins 1 & 2 are Receive. Pins 4 & 5 are Transmit.

A.3 CIRCUIT DEFAULTS

- E1 Line Coding = HDB3.
- T1 Line Coding = B8ZS; Line Build Out Rx = Automatic; Line Build Out Tx = 0.

A.4 CIRCUIT CONNECTOR

- Dual BNC and RJ48C (Model 2113), strap selectable
- RJ48C connector (Model 2115)

A.5 LED INDICATORS

- Three LED indicators: Power, Link, Frame

A.6 POWER AND POWER SUPPLY SPECIFICATIONS

- AC power supply
- Connection to the CopperLink-T T1/E1 Extender requires +5VDC $\pm 5\%$ DC power (1.0A minimum). Center pin is +5V. The barrel type plug has a 2.5/5.5/10mm I.D./O.D./shaft length dimensions
- CopperLink-T T1/E1 Extender's rated voltage: 5.0 VDC
- CopperLink-T T1/E1 Extender's rated current: 1A DC

A.7 ENVIRONMENTAL

- Temperature: 32–122°F (0–50°C)
- Relative Humidity: 5–95%, non-condensing
- Altitude: 0–15,000 ft (0–4,572 m)

A.8 TRANSMISSION LINE

- Single Twisted Pair

A.9 LINE CODING

- TC-PAM (Trellis Coded Pulse Amplitude Modulation)

A.10 LINE INTERFACE

- Transformer coupled, 2500 VRMS isolation

A.11 LINE PHYSICAL CONNECTION

- RJ-45, 2-wire polarity insensitive pins 4 and 5

APPENDIX B

FACTORY DEFAULT DIP SWITCH CONFIGURATION

Note This information is provided for informational purposes only. These settings should not be changed other than by instructions from Patton Support, lest the unit be rendered inoperable.

B.1 SWITCH S1 - FACTORY DEFAULT CONFIGURATION

Table 3: S1 Factory Default Dip Switch Configuration

Switch	2113/L/EUI	2113/R/EUI	2115/L/EUI	2115/R/EUI
Switch 1-1	ON	ON	ON	ON
Switch 1-2	ON	ON	ON	ON
Switch 1-3	ON	ON	ON	ON
Switch 1-4	ON	ON	OFF	OFF
Switch 1-5	ON	ON	OFF	OFF
Switch 1-6	OFF	OFF	ON	ON
Switch 1-7	OFF	OFF	ON	ON
Switch 1-8	ON	ON	ON	ON

B.2 SWITCH S2 - FACTORY DEFAULT CONFIGURATION

Table 4: S2 Factory Default Dip Switch Configuration

Switch	2113/L/EUI	2113/R/EUI	2115/L/EUI	2115/R/EUI
Switch 2-1	OFF	OFF	OFF	OFF
Switch 2-2	OFF	OFF	OFF	OFF
Switch 2-3	OFF	OFF	OFF	OFF
Switch 2-4	OFF	ON	OFF	ON
Switch 2-5	ON	OFF	ON	OFF
Switch 2-6	OFF	OFF	ON	ON
Switch 2-7	OFF	OFF	ON	ON
Switch 2-8	ON	ON	ON	ON

