

# USER MANUAL

---

## CopperLink™ Ethernet Extenders Model 2158 & 2168



**PE PATTON**  
**Electronics Co.**



Part# 07M2158\_2168 Rev. A  
Doc# 058091U  
Revised 3/24/03

SALES OFFICE  
(301) 975-1000  
TECHNICAL SUPPORT  
(301) 975-1007

An ISO-9001 Certified  
Company

**CONTENTS**

- 1.0 Warranty Information ..... 4**
- 1.1 Radio and TV Interference..... 4
- 1.2 CE Notice..... 4
- 1.3 Service..... 5
- 2.0 General Information..... 6**
- 2.1 Features..... 6
- 2.2 Description..... 6
- 3.0 Installation..... 8**
- 3.1 Standalone unit installation..... 8
- 3.2 Rack card installation..... 9
- 3.3 Connecting the Twisted-Pair Line Interface..... 10
- 3.4 Connecting the 10/100Base-T Ethernet Interface ..... 11
  - Connecting the 10/100Base-T Ethernet Port to a Hub..... 12
  - Connecting the 10/100Base-T Ethernet Port to a PC (DTE)..... 12
- 3.5 Connecting Power ..... 12
- 4.0 Configuration (Model 2168 Only) ..... 14**
- 4.1 Configuring the hardware DIP switches..... 14
- 4.2 Configuring DIP Switch S1 ..... 16
  - Switch S1-1: Ethernet Auto Sense ..... 16
  - Switches S1-2 and S1-4: Data Rate..... 16
- 5.0 Operation..... 18**
- 5.1 Power Up..... 18
- 5.2 Front Panel LED Status Monitors ..... 18
- A Specifications ..... 21**
- A.1 LAN Connection ..... 21
- A.2 Transmission Line ..... 21
- A.3 CopperLink Line Rate ..... 21
- A.4 CopperLink Distance ..... 21
- A.5 CopperLink Surge Suppressor ..... 21
- A.6 LED Status Indicators ..... 21
- A.7 Power Supply ..... 21
- A.8 Temperature Range ..... 22
- A.9 Humidity ..... 22
- A.10 Dimensions ..... 22
- B Model 2158 Series Factory Replacement Parts and Accessories..... 23**
- C Model 2168 Series Factory Replacement Parts and Accessories..... 24**

<b>D</b>	<b>CopperLink Series Interface Pin Assignment.....</b>	<b>25</b>
D.1	10/100Base-T Interface .....	25
	RJ-45 .....	25
D.2	CopperLink Interface .....	25
	RJ-45 .....	25
	Terminal Block.....	25
<b>E</b>	<b>Distance Chart, Based on 24 AWG (0.5 MM) .....</b>	<b>26</b>

## 1.0 WARRANTY INFORMATION

**Patton Electronics** warrants all CopperLink Ethernet Extender components to be free from defects, and will—at our option—repair or replace the product should it fail within one year from the first date of the shipment.

This warranty is limited to defects in workmanship or materials, and does not cover customer damage, abuse or unauthorized modification. If this product fails or does not perform as warranted, your sole recourse shall be repair or replacement as described above. Under no condition shall **Patton Electronics** be liable for any damages incurred by the use of this product. These damages include, but are not limited to, the following: lost profits, lost savings and incidental or consequential damages arising from the use of or inability to use this product. **Patton Electronics** specifically disclaims all other warranties, expressed or implied, and the installation or use of this product shall be deemed an acceptance of these terms by the user.

**Note** Conformity documents of all Patton products can be viewed online at [www.patton.com](http://www.patton.com) under the appropriate product page.

### 1.1 RADIO AND TV INTERFERENCE

The CopperLink Ethernet Extender generates and uses radio frequency energy, and if not installed and used properly—that is, in strict accordance with the manufacturer's instructions—may cause interference to radio and television reception. The CopperLink Ethernet Extender has been tested and found to comply with the limits for a Class A computing device in accordance with specifications in Subpart B of Part 15 of FCC rules, which are designed to provide reasonable protection from such interference in a commercial installation. However, there is no guarantee that interference will not occur in a particular installation. If the CopperLink Ethernet Extender does cause interference to radio or television reception, which can be determined by disconnecting the unit, the user is encouraged to try to correct the interference by one or more of the following measures: moving the computing equipment away from the receiver, re-orienting the receiving antenna and/or plugging the receiving equipment into a different AC outlet (such that the computing equipment and receiver are on different branches).

### 1.2 CE NOTICE

The CE symbol on your Patton Electronics equipment indicates that it is in compliance with the Electromagnetic Compatibility (EMC) directive and the Low Voltage Directive (LVD) of the European Union (EU). A Certificate of Compliance is available by contacting Technical Support.

### **1.3 SERVICE**

All warranty and non-warranty repairs must be returned freight prepaid and insured to Patton Electronics. All returns must have a Return Materials Authorization number on the outside of the shipping container. This number may be obtained from Patton Electronics Technical Services at:

- Tel: **+1 (301) 975-1007**
- Email: **support@patton.com**
- URL: **http://www.patton.com**

**Note** Packages received without an RMA number will not be accepted.

## **2.0 GENERAL INFORMATION**

Thank you for your purchase of this Patton Electronics product. This product has been thoroughly inspected and tested and is warranted for one year for parts and labor. If any questions or problems arise during installation or use of this product, contact Patton Electronics Technical Support at +1 (301) 975-1007.

### **2.1 FEATURES**

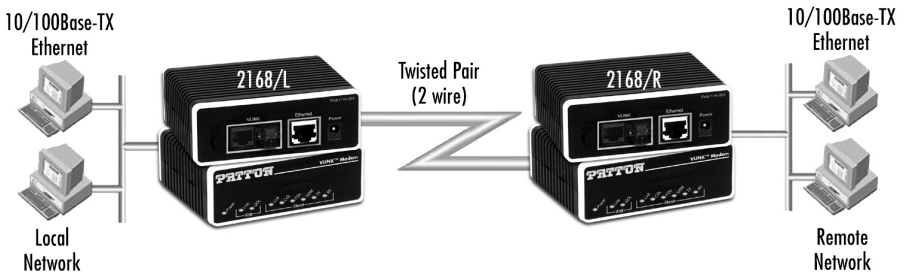
- Easy to install standalone CopperLink Ethernet Extenders (no configuration required)
- Auto-sensing full or half-duplex Ethernet
- Auto-sensing 10/100Base-T
- Extends network connections up to 6,000 ft (1.83 km) over 2-wire 24-AWG unconditioned lines
- Switch selectable line rates up to 16.67 Mbps (Model 2168 only)
- 7 symmetric or asymmetric settings via DIP switch (Model 2168 only)
- Transparent operation
- LED indicators for Power, Ethernet Link & Activity, CopperLink link & Quality of Line (QOL)
- Surge suppression up to 20 kA (8/20  $\mu$ s)
- Available in rack-mount or standalone configurations
- Made in the USA

### **2.2 DESCRIPTION**

The Patton Electronics CopperLink/L and CopperLink/R Ethernet Extenders provide high-speed LAN connections between peered Ethernet LANs, remote PCs, or any other network enabled 10/100Base-T device.

Operating in pairs, a CopperLink/L (local) located at one end of the LAN extension and a CopperLink/R (remote) at the other end, these units can automatically forward LAN broadcasts, multicasts, and frames across a 2-wire voice-grade twisted-pair link. The data is passed transparently (unmodified) through the CopperLink Ethernet Extenders. The CopperLink Ethernet Extenders automatically add and delete MAC addresses, only

passing packets across the CopperLink link that are meant for the remote peered LAN.



**Figure 1.** Typical application

The CopperLink/L modem and CopperLink/R modem work together to create a transparent extension between two peered Ethernet LANs. Figure 1 shows a typical point-to-point application.

### 3.0 INSTALLATION

Because the CopperLink Ethernet Extender requires no configuration, it can be installed quickly. If you are installing a standalone unit, refer to section 3.1 “Standalone unit installation”. Otherwise, refer to section 3.2 “Rack card installation”.

**Note** If asymmetric transmission or line rates other than 12.5 Mbps are required (Model 2168 only), refer to section 4.0, “Configuration (Model 2168 Only)” on page 14.

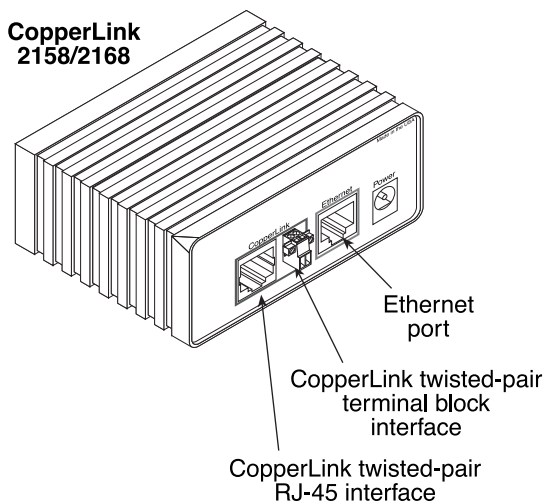
#### 3.1 STANDALONE UNIT INSTALLATION

Do the following:

1. Connect the line interface between the units (refer to section 3.3, “Connecting the Twisted-Pair Line Interface” on page 10)

**Note** See Figure 2 for the standalone unit’s rear panel arrangements.

2. Connect the Ethernet interface (refer to section 3.4, “Connecting the 10/100Base-T Ethernet Interface” on page 11).
3. Connect the power plug (refer to section 3.5, “Connecting Power” on page 12).



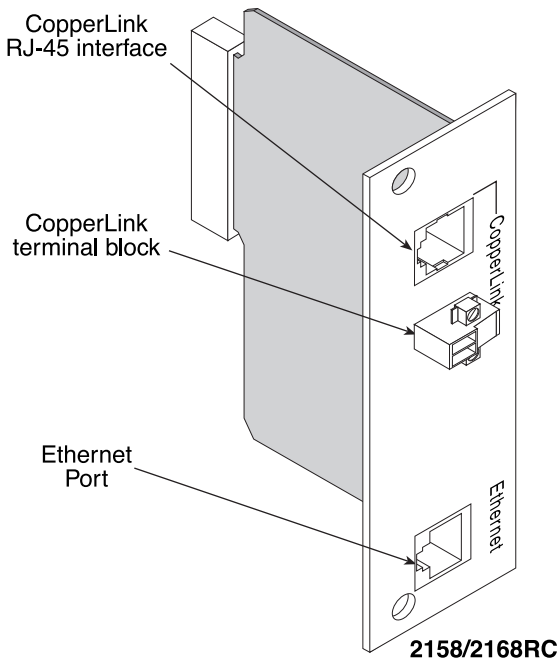
**Figure 2.** CopperLink Ethernet Extender standalone rear panel

### 3.2 RACK CARD INSTALLATION

The CopperLink Ethernet Extender rack card comprised a front card and a rear card. Do the following to install the cards into the rack chassis:

1. Slide the rear card into the back of the chassis along the metal rails.
2. Secure the rear card using the supplied metal screws.
3. Slide the front card into the chassis until you feel resistance as the front card engages the rear card. When that happens, *gently* push the front card forward until it is fully seated in the card-edge receptacle of the rear card (it should *click* into place).
4. Secure the front card using the captive fasteners.

**Note** The Model 1001R14 chassis supports “hot swapping” of cards, so it is not necessary to power down the rack when you install or remove a CopperLink Ethernet Extender rack card.



**Figure 3.** CopperLink Ethernet Extender rack cards

5. Connect the line interface between the units (refer to section 3.3, “Connecting the Twisted-Pair Line Interface” on page 10)

**Note** See Figure 3 for the rack card’s panel arrangements.

6. Connect the Ethernet interface (refer to section 3.4, “Connecting the 10/100Base-T Ethernet Interface” on page 11).

### 3.3 CONNECTING THE TWISTED-PAIR LINE INTERFACE

The CopperLink Ethernet Extender supports communication between two peer Ethernet LAN sites over a distance of up to 6,000 ft (1.83 km) over 24 AWG (0.5 mm) twisted-pair wire.

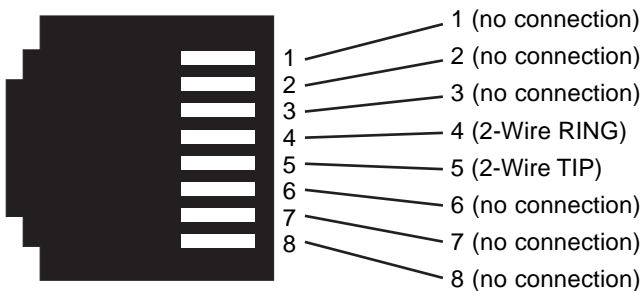
**Note** Actual distance and link performance may vary depending on the environment and type/gauge of wire used.

Follow the steps below to connect the CopperLink Ethernet Extenders interfaces.

**Note** The CopperLink units work in pairs. One of the CopperLink units must be an L (local), and the other unit must be an R (remote). It does not matter which end is the L and which is the R. The link is always initiated by the R. As long as the L is powered on, the R can establish a link by being powered on or by having its power reset.

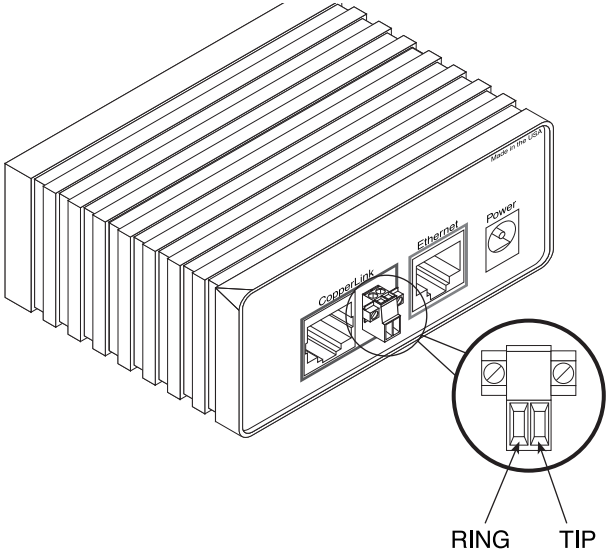
1. To function properly, the two CopperLink Ethernet Extenders must be connected together using twisted-pair, unconditioned, dry, metal wire, between 19 (0.9mm) and 26 AWG (0.4mm). Leased circuits that run through signal equalization equipment are not acceptable.
2. The CopperLink Ethernet Extenders are equipped with two interface jacks that can be used on the CopperLink interface, an RJ-45 or a terminal block. These CopperLink interfaces are a two-wire interface. Observe the signal/pin relationships on the CopperLink Ethernet Extender's CopperLink interface jacks.

The **RJ-45 connector** on the CopperLink Ethernet Extender's twisted pair interface is **polarity insensitive** and is wired for a two-wire interface. The signal/pin relationship is shown in Figure 4.



**Figure 4.** CopperLink Ethernet Extender (RJ-45) twisted pair line interface.

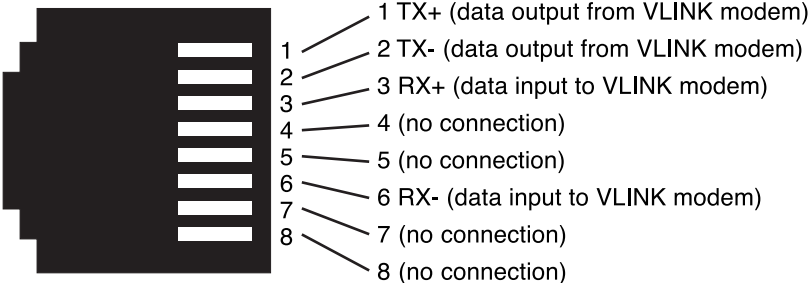
The **terminal block connector** on the CopperLink Ethernet Extender's twisted pair interface **is polarity insensitive** and is wired for a two-wire interface. The signal/pin relationships is shown in Figure 5.



**Figure 5.** CopperLink Ethernet Extender twisted pair line interface.

**3.4 CONNECTING THE 10/100BASE-T ETHERNET INTERFACE**

The shielded RJ-45 port labeled *Ethernet* is the 10/100Base-T interface. This port is designed to connect directly to a 10/100Base-T network. Figure 6 shows the signal/pin relationships on this interface. You may connect this port to another Ethernet device via a Type 4 or Type 5 cable that is up to 328 ft long.



**Figure 6.** CopperLink Ethernet Extender 10/100Base-T RJ-45 Connector Pinout.

### Connecting the 10/100Base-T Ethernet Port to a Hub

The CopperLink Ethernet Extender 10/100Base-T interface is configured as DTE (Data Terminal Equipment), just like a 10/100Base-T network interface card in a PC. Therefore, it “expects” to connect to a 10/100Base-T Hub using a straight-through RJ-45 cable. Figure 7 diagrams the cable wiring for connecting the CopperLink Ethernet Extender to a 10/100Base-T hub.

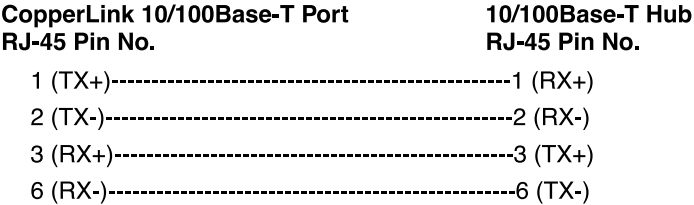


Figure 7. Wiring diagram for connecting the CopperLink Ethernet Extender to a 10/100Base-T hub

### Connecting the 10/100Base-T Ethernet Port to a PC (DTE)

The CopperLink Ethernet Extender 10/100Base-T interface is configured as DTE (Data Terminal Equipment). If you wish to connect the CopperLink Ethernet Extender to another DTE devices such as 10/100Base-T network interface card in a PC (or CopperLink Ethernet Extenders in a back-to-back arrangement), you must construct a 10/100Base-T crossover cable as shown in Figure 8.

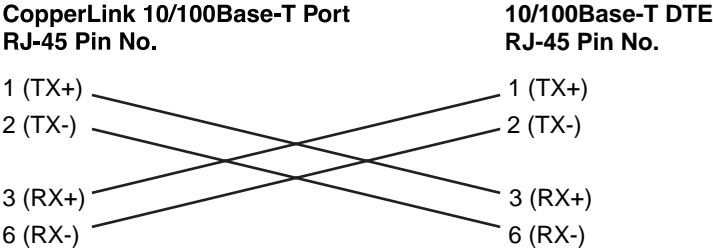


Figure 8. 10/100Base-T crossover cable

### 3.5 CONNECTING POWER

An external AC or DC power supply is available separately. This connection is made via the barrel jack on the rear panel of the CopperLink Ethernet Extender. No configuration is necessary for the power supply (See Appendix B for domestic and international power supply and cord options).

DC power (supplied via the power supply jack to the CopperLink Ethernet Extender) must meet the following requirements; DC power supplied must be regulated +5VDC  $\pm 5\%$ , 1.0A minimum. Center pin is +5V. The barrel type plug has a 2.5/5.5/10mm I.D./O.D./Shaft Length dimensions.

The CopperLink Ethernet Extender does not have a power switch, so it powers up as soon as it is plugged in.



**WARNING**

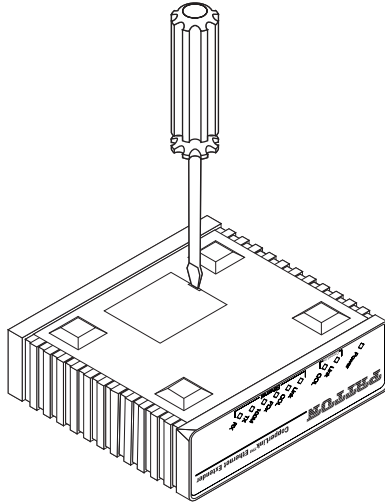
**There are no user-serviceable parts in the CopperLink Ethernet Extender. Fuse replacement should only be performed by qualified service personnel. Contact Patton Electronics Technical support at (301) 975-1007 for more information.**

## 4.0 CONFIGURATION (MODEL 2168 ONLY)

The CopperLink Ethernet Extender has eight DIP switches for configuring the unit for a wide variety of applications. This section describes switch locations and explains the different configurations.

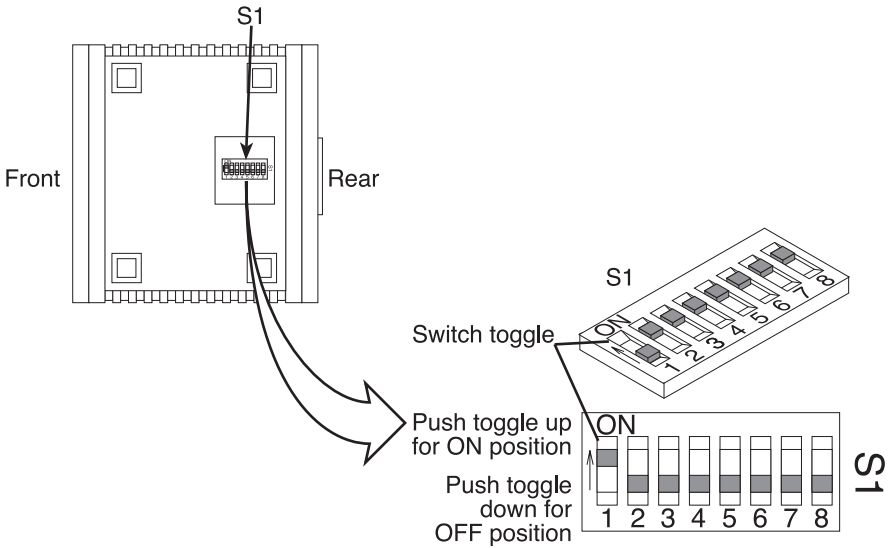
### 4.1 CONFIGURING THE HARDWARE DIP SWITCHES

Using a small flat-tip screwdriver, remove the protective cover located on the underside of the CopperLink Ethernet Extender (see Figure 9).

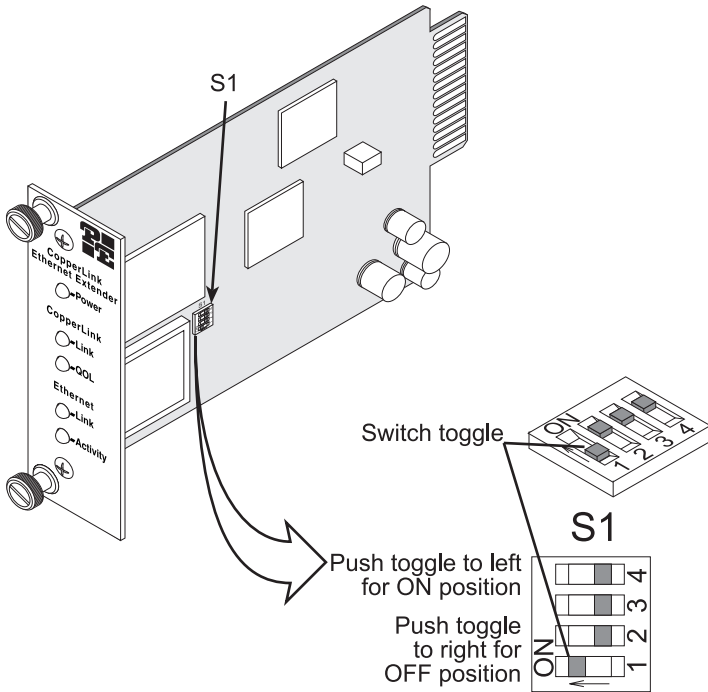


**Figure 9.** Removing protective cover

Figure 10 and Figure 11 on page 15 show the orientation of the DIP switches in the On and Off positions.



**Figure 10.** Model 2168 standalone modem DIP switch orientation



**Figure 11.** Model 2168 rack card DIP switch orientation

## 4.2 CONFIGURING DIP SWITCH S1

DIP switch S1 is where you configure the CopperLink line rate, symmetric or asymmetric, Ethernet full auto negotiation capability (100Base-T full or half duplex, 10Base-T full or half duplex) or limited auto sense (only 100Base-T half duplex, 10Base-T full or half duplex).

### Switch S1-1: Ethernet Auto Sense

Use switch S1-1 to configure the unit for full auto sense capability or limited auto sense capability. Full Auto sense capability consists of standard Ethernet Auto sensing (100BaseT full duplex, 100BaseT half duplex, 10BaseT full duplex, and 10BaseT half duplex). Limited Auto sensing capability consists on only auto sensing for 100BaseT half duplex, 10BaseT full duplex, and 10BaseT half duplex. The limited auto negotiation feature is used when an Ethernet device does not comply with IEEE 802.3x (back pressure flow control) at 100M full duplex.

**Table 1:** Ethernet Auto Negotiation Selection Chart

<b>S1-1</b>	<b>Setting</b>
OFF	Full Auto Negotiation (Factory Default) (100 Mbps, Full or Half Duplex) (10 Mbps, Full or Half Duplex)
ON	Limited Auto Negotiation (100 Mbps Half Duplex) 10 Mbps Full or Half Duplex)

### Switches S1-2 and S1-4: Data Rate

Use switches S1-2 and S1-4 to configure the CopperLink line rates.

**Table 2:** Symmetric CopperLink Line Rates Selection Chart

<b>S1-2</b>	<b>S1-3</b>	<b>S1-4</b>	<b>Symmetric Line Rate</b>
ON	ON	ON	6.25 Mbps
ON	ON	OFF	9.38 Mbps
ON	OFF	OFF	12.5 Mbps (Factory Default)
ON	OFF	ON	16.67 Mbps

**Table 3:** Asymmetric CopperLink Line Rates Selection Chart

<b>S1-2</b>	<b>S1-3</b>	<b>S1-4</b>	<b>Asymmetric Line Rates DS/US</b>
OFF	OFF	ON	4.17 Mbps/1.56 Mbps (Mode 0)
OFF	ON	ON	9.38 Mbps/1.56 Mbps
OFF	ON	OFF	16.67 Mbps/2.34 Mbps

**Table 4:** Reserved for future use

<b>S1-5</b>	<b>S1-6</b>	<b>S1-7</b>	<b>S1-8</b>	<b>Reserved for future use</b>
OFF	OFF	OFF	OFF	Reserved (Factory Default)

## 5.0 OPERATION

Once the CopperLink Ethernet Extenders are properly installed, they should operate transparently. No user settings required. This section describes reading the LED status monitors.

### 5.1 POWER UP

Before applying power to the CopperLink Ethernet Extender, please review section 3.5, “Connecting Power” on page 12 to verify that the unit is connected to the appropriate power source.

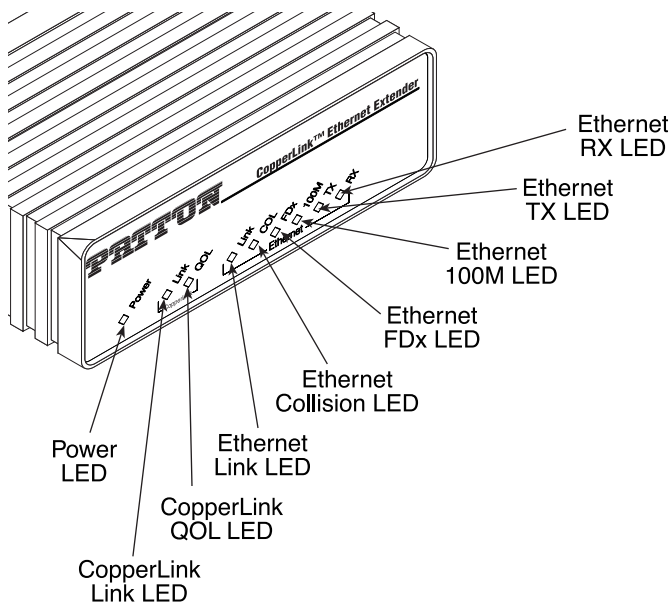


**WARNING**

**There are no user-serviceable parts in the CopperLink Ethernet Extender. Fuse replacement should only be performed by qualified service personnel. Contact Patton Electronics Technical support at (301) 975-1007 for more information.**

### 5.2 FRONT PANEL LED STATUS MONITORS

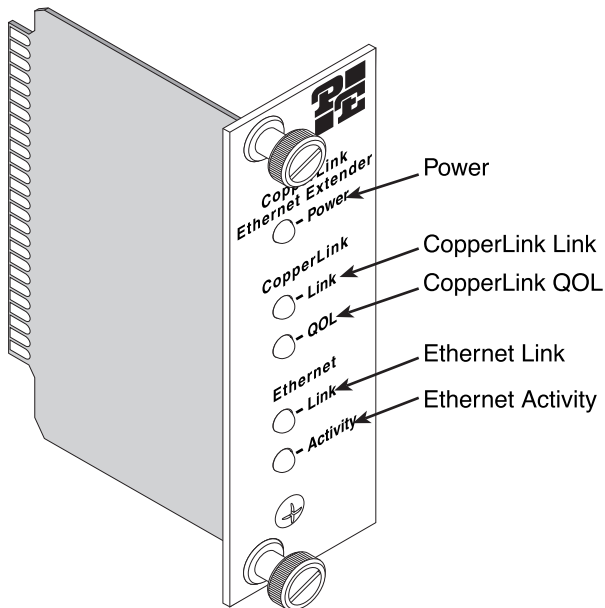
The CopperLink Ethernet Extender features nine front panel LEDs (five on the rack card) that monitor power, the Ethernet signals, and the CopperLink connection. Figure 12 (standalone version) and Figure 13 on page 20 (rack card version) show the front panel LEDs. Table 5 on page 19 describes the LED functions for the standalone model, Table 6 on page 20 describes the LED functions for the rack card.



**Figure 12.** CopperLink Ethernet Extender standalone unit front panel

**Table 5:** Front panel LED description for standalone modem

LED	Description
Power	<b>On (green)</b> when power is applied to the unit. <b>Off</b> when no power is applied to the unit.
CopperLink - Link	<b>On (green)</b> when the end-to-end CopperLink link between the units is established. <b>Off</b> when the link has not been established or when the link fails
CopperLink - QOL	<b>Flashes yellow</b> at different rates to indicate the amount of error correction taking place on data passing over the CopperLink link. This is a normal operating condition and all data is passing correctly over the link even if the link is <b>solidly yellow</b> . However, if the LED is <b>solid yellow</b> and the <b>CopperLink Link LED is Off</b> , <b>Off</b> when no power is applied to the unit.
Ethernet - Link	<b>On (green)</b> when the 10/100Base-T Ethernet link has been established. <b>Off</b> when the 10/100Base-T Ethernet link has not been established or when the link fails.
Ethernet - COL (Collision)	<b>Flashes yellow</b> to indicate Ethernet collisions are occurring.
Ethernet - FDx (Duplex)	<b>On (yellow)</b> when in full-duplex Ethernet mode. <b>Off</b> when when operating in half-duplex Ethernet mode.
Ethernet - 100M	<b>On (yellow)</b> when the link has not been established or when operating in 100-Mbps Ethernet mode. <b>Off</b> when operating in 10-Mbps Ethernet mode.
Ethernet - TX	<b>Flashes yellow</b> when data is transmitted from the unit to the LAN.
Ethernet - RX	<b>Flashes yellow</b> when data is received at the unit from the LAN.



**Figure 13.** CopperLink Ethernet Extender rack card front panel

**Table 6:** Front panel LED description for rack card modem

LED	Description
Power	Solid GREEN to indicate the unit is powered on.
CopperLink Ethernet Extender Link	(Active Green) Solid green (ON) to indicate that the end-to-end CopperLink link between the CopperLink Ethernet Extenders is established. The CopperLink Ethernet Extender LED is OFF when the link is down.
CopperLink Ethernet Extender QOL	(Active Yellow) Flashes YELLOW to indicate the processor is correcting an error in the data thus preventing the transmission of corrupted data to the Ethernet port. The more error corrections, the more often the LED blinks. If the light remains lit continuously, it means that the CopperLink line is noisy—although the data at the Ethernet port remains uncorrupted. Further impairment of the line however, risks having the line fail, as indicated by the green CopperLink Ethernet Extender Link LED extinguishing.
Ethernet Link	(Active Green) Solid Green indicates that 10/100Base-T Ethernet link has been established.
Ethernet Activity	(Active Yellow) Flashes yellow to indicate Ethernet activity on the CopperLink Ethernet Extender's 10/100Base-T Ethernet port.

## **APPENDIX A**

### **SPECIFICATIONS**

#### **A.1 LAN CONNECTION**

- Shielded RJ-45, 10/100Base-T, IEEE 802.3 Ethernet
- CopperLink Connection: RJ-45 and Terminal Block

#### **A.2 TRANSMISSION LINE**

Two-wire unconditioned twisted pair.

#### **A.3 COPPERLINK LINE RATE**

**Model 2168**—16.67 Mbps, symmetric upstream/downstream. Additional symmetric and asymmetric rates are available via DIP switch settings.

**Model 2158**—Fixed 12.5 Mbps, symmetric upstream/downstream.

#### **A.4 COPPERLINK DISTANCE**

6,000 ft (1.83 km) at 1.56 Mbps upstream/4.17 Mbps downstream

**Note** Distances depend on selected line rate.

#### **A.5 COPPERLINK SURGE SUPPRESSOR**

Gas tube with maximum current surge: 20 kA (8120  $\mu$ s).

#### **A.6 LED STATUS INDICATORS**

- Power (Green)
- CopperLink: Link (Green) & QOL (Red)
- Ethernet: Link (Green), Collision (Yellow), Duplex (Yellow), 10/100M (Yellow), Transmit (Yellow), and Receive (Yellow)

#### **A.7 POWER SUPPLY**

Input power: 5 VDC, 1A

Power consumption: 450 mA at 5 VDC

External AC and DC options:

- AC: 120 VAC, 220 VAC, and UI (120–240 VAC)
- DC: 12 VDC, 24 VDC and 48 VDC

**A.8 TEMPERATURE RANGE**

32–122°F (0–50°C)

**A.9 HUMIDITY**

Up to 90% non-condensing.

**A.10 DIMENSIONS**

1.58H x 4.16W x 3.75D in. (10.6H x 4.1W x 8.8D cm)

**APPENDIX B**  
**MODEL 2158 SERIES FACTORY**  
**REPLACEMENT PARTS AND ACCESSORIES**

Patton Model #	Description
<b>Base Models</b>	
2158/L	Local CopperLink Ethernet Extender, no power supply
2158/R	Remote CopperLink Ethernet Extender, no power supply
2158-2PK	CopperLink Ethernet Extender Kit: includes one local (L) and one remote (R) Model 2158, no power supply
07M2158_2168-A	User Manual
<b>Power Supplies</b>	
08055DCUI	100-240VAC (+5V reg. DC/2A) Universal Input Adapter.
08055-120-5-1	120 VAC (+5V reg. DC/1A) Input Adapter
12V-PSM	12 VDC Input Adapter
24V-PSM	24 VDC Input Adapter
48V-PSM	48 VDC Input Adapter
<b>Power Cords*</b>	
0805US	American Power Cord
0805EUR	European Power Cord CEE 7
0805UK	United Kingdom Power Cord
0805AUS	Australian Power Cord
0805DEN	Denmark Power Cord
0805FR	France/Belgium Power Cord
0805IN	India Power Cord
0805IS	Israel Power Cord
0805JAP	Japan Power Cord
0805SW	Switzerland Power Cord

\*Only required with optional UI power supply (08055DCUI)

**APPENDIX C**  
**MODEL 2168 SERIES FACTORY**  
**REPLACEMENT PARTS AND ACCESSORIES**

Patton Model #	Description
<b>Base Models</b>	
2168RC/L	Local Multi Rate CopperLink Rack Card
2168RC/R	Remote Multi Rate CopperLink Rack Card
2168/L	Local Multi Rate CopperLink Ethernet Extender, no power supply
2168/R	Remote Multi Rate CopperLink Ethernet Extender, no power supply
2168-2PK	Multi Rate CopperLink Ethernet Extender Kit: includes one local (L) and one remote (R) CopperLink Ethernet Extender, no power supply
07M2158_2168-A	User Manual
<b>Power Supplies</b>	
08055DCUI 08055-120-5-1	100-240VAC (+5V reg. DC/2A) Universal Input Adapter. 120 VAC (+5V reg. DC/1A) Input Adapter
12V-PSM	12 VDC Input Adapter
24V-PSM	24 VDC Input Adapter
48V-PSM	48 VDC Input Adapter
<b>Power Cords*</b>	
0805US	American Power Cord
0805EUR	European Power Cord CEE 7
0805UK	United Kingdom Power Cord
0805AUS	Australian Power Cord
0805DEN	Denmark Power Cord
0805FR	France/Belgium Power Cord
0805IN	India Power Cord
0805IS	Israel Power Cord
0805JAP	Japan Power Cord
0805SW	Switzerland Power Cord

\*Only required with optional UI power supply (08055DCUI)

**APPENDIX D**  
**COPPERLINK SERIES INTERFACE PIN ASSIGNMENT**

**D.1 10/100BASE-T INTERFACE**

**RJ-45**

- Pin 1: TX+
- Pin 2: TX-
- Pin 3: RX+
- Pin 6: RX-
- Pins 4, 5, 7, 8: no connection

**D.2 COPPERLINK INTERFACE**

**RJ-45**

- Pin 4: RING
- Pin 5: TIP
- Pins 1, 2, 3, 6, 7, 8: no connection

**Terminal Block**

See Figure 5 on page 11.

## APPENDIX E

DISTANCE CHART, BASED ON 24 AWG (0.5 MM)

<b>Symm Line Rate (DS/US)</b>	<b>Distance in feet (km)</b>
6.25 Mbps	4,500 (1.37)
9.38 Mbps	4,150 (1.26)
12.5 Mbps	4,000 (1.22)
16.67 Mbps	3,300 (1.00)

<b>Asymm Line Rate (DS/US)</b>	<b>Distance in feet (km)</b>
4.17 Mbps/1.56 Mbps (Mode 0)	6,000 (1.83)
9.38 Mbps/1.56 Mbps	5,500 (1.68)
16.67 Mbps/2.34 Mbps	5,000 (1.52)

**Note** Model 2158 is fixed at 12.5 Mbps, 4,000 ft (1,220 m).



