

# USER MANUAL

---

## MODEL 2173R Ruggedized High Speed Ethernet Extender



An ISO-9001 Certified  
Company

Part# 07M12173R-UM  
Rev. B  
Revised 2/3/12

SALES OFFICE  
(301) 975-1000  
TECHNICAL SUPPORT  
(301) 975-1007

## CONTENTS

<b>1.0</b>	<b>Warranty Information .....</b>	<b>4</b>
1.1	Compliance.....	4
	EMC Compliance:.....	4
	Low-Voltage Directive (Safety):.....	4
	PSTN:.....	4
1.2	Radio and TV Interference (FCC Part 15) .....	4
1.3	CE Declaration of Conformity .....	5
1.4	Authorized European Representative .....	5
1.5	Service.....	5
1.6	Safety When Working With Electricity .....	6
<b>2.0</b>	<b>General Information.....</b>	<b>8</b>
2.1	Features.....	8
2.2	Description.....	8
<b>3.0</b>	<b>Installation.....</b>	<b>9</b>
3.1	Connecting the Twisted-Pair Line Interface .....	10
3.2	Connecting the 10/100Base-T Ethernet Interface .....	11
3.3	Connecting Power .....	12
<b>4.0</b>	<b>Configuration .....</b>	<b>12</b>
4.1	Configuring the hardware DIP switches.....	12
4.2	Configuring DIP Switch S1 .....	14
<b>5.0</b>	<b>Operation.....</b>	<b>14</b>
5.1	Power Up.....	14
5.2	Front Panel LED Status Monitors .....	15
<b>A</b>		
	<b>Specifications .....</b>	<b>16</b>
A.1	LAN Connection .....	16
A.2	Transmission Line .....	16
A.3	CopperLINK Line Rate and CopperLINK Distance .....	16
A.4	LED Status Indicators .....	16
A.5	Power Supply .....	16
A.6	Temperature Range .....	16
A.7	Humidity .....	16
A.8	Dimensions .....	16
<b>B</b>		
	<b>Model 2173R Factory Replacement Parts and Accessories.....</b>	<b>17</b>
<b>C</b>		
	<b>Model 2173R Interface Pin Assignment.....</b>	<b>18</b>
C.1	10/100Base-T Interface .....	18
	RJ-45.....	18
C.2	CopperLINK Interface .....	18
	RJ-45.....	18

**D**

**Sample Rates/Distance Chart, Based on 24 AWG (0.5 MM) . 19**

## 1.0 WARRANTY INFORMATION

**Patton Electronics** warrants all Model 2173R components to be free from defects, and will—at our option—repair or replace the product should it fail within one year from the first date of the shipment.

This warranty is limited to defects in workmanship or materials, and does not cover customer damage, abuse or unauthorized modification. If this product fails or does not perform as warranted, your sole recourse shall be repair or replacement as described above. Under no condition shall **Patton Electronics** be liable for any damages incurred by the use of this product. These damages include, but are not limited to, the following: lost profits, lost savings and incidental or consequential damages arising from the use of or inability to use this product. **Patton Electronics** specifically disclaims all other warranties, expressed or implied, and the installation or use of this product shall be deemed an acceptance of these terms by the user.

**Note** Conformity documents of all Patton products can be viewed online at [www.patton.com](http://www.patton.com) under the appropriate product page.

### 1.1 COMPLIANCE

#### **EMC Compliance:**

- FCC Part 15, Class A
- EN55022, Class A
- EN55024
- A-tick

#### **Low-Voltage Directive (Safety):**

- IEC/EN60950-1, 2nd Edition
- AS/NZS 60950-1, A-tick

#### **PSTN:**

- This device is not intended nor approved for connection to the PSTN.

### 1.2 RADIO AND TV INTERFERENCE (FCC PART 15)

This equipment generates and uses radio frequency energy, and if not installed and used properly—that is, in strict accordance with the manufacturer's instructions—may cause interference to radio and television

reception. This equipment has been tested and found to comply with the limits for a Class A computing device in accordance with the specifications in Subpart B of Part 15 of FCC rules, which are designed to provide reasonable protection from such interference in a commercial installation. However, there is no guarantee that interference will not occur in a particular installation. If the equipment causes interference to radio or television reception, which can be determined by disconnecting the cables, try to correct the interference by one or more of the following measures: moving the computing equipment away from the receiver, re-orienting the receiving antenna, and/or plugging the receiving equipment into a different AC outlet (such that the computing equipment and receiver are on different branches).

### **1.3 CE DECLARATION OF CONFORMITY**

We certify that the apparatus described above conforms to the requirements of Council Directive 2004/108/EC on the approximation of the laws of the member states relating to electromagnetic compatibility; and Council Directive 2006/95/EC on the approximation of the laws of the member states relating to electrical equipment designed for use within certain voltage limits.

The safety advice in the documentation accompanying this product shall be obeyed. The conformity to the above directive is indicated by the CE sign on the device.

### **1.4 AUTHORIZED EUROPEAN REPRESENTATIVE**

D R M Green, European Compliance Services Limited.  
Avalon House, Marcham Road, Abingdon, Oxon OX14 1UD, UK

### **1.5 SERVICE**

All warranty and non-warranty repairs must be returned freight prepaid and insured to Patton Electronics. All returns must have a Return Materials Authorization number on the outside of the shipping container. This number may be obtained from Patton Electronics Technical Services at:

- Tel: **+1 (301) 975-1007**
- Email: **support@patton.com**
- URL: **http://www.patton.com**

**Note** Packages received without an RMA number will not be accepted.

## 1.6 SAFETY WHEN WORKING WITH ELECTRICITY



- This device contains no user serviceable parts. This device can only be repaired by qualified service personnel.
- Do not open the device when the power cord is connected. For systems without a power switch and without an external power adapter, line voltages are present within the device when the power cord is connected.
- For devices with an external power adapter, the power adapter shall be a listed Limited Power Source. The mains outlet that is utilized to power the device shall be within 10 feet (3 meters) of the device, shall be easily accessible, and protected by a circuit breaker in compliance with local regulatory requirements.
- For AC powered devices, ensure that the power cable used meets all applicable standards for the country in which it is to be installed.
- For AC powered devices which have 3 conductor power plugs (L1, L2 & GND or Hot, Neutral & Safety/Protective Ground), the wall outlet (or socket) must have an earth ground.
- For DC powered devices, ensure that the interconnecting cables are rated for proper voltage, current, anticipated temperature, flammability, and mechanical serviceability.
- WAN, LAN & PSTN ports (connections) may have hazardous voltages present regardless of whether the device is powered ON or OFF. PSTN relates to interfaces such as telephone lines, FXS, FXO, DSL, xDSL, T1, E1, ISDN, Voice, etc. These are known as “hazardous network voltages” and to avoid electric shock use caution when working near these ports. When disconnecting cables for these ports, detach the far end connection first.
- Do not work on the device or connect or disconnect cables during periods of lightning activity.



In accordance with the requirements of council directive 2002/96/EC on Waste of Electrical and Electronic Equipment (WEEE), ensure that at end-of-life you separate this product from other waste and scrap and deliver to the WEEE collection system in your country for recycling.



This device is **NOT** intended nor approved for connection to the PSTN. It is intended only for connection to customer premise equipment.



When the 2173R is mounted, it shall be secured in such a way as to withstand a vertical shear force of 50N or 14 pounds.



Electrostatic Discharge (ESD) can damage equipment and impair electrical circuitry. It occurs when electronic printed circuit cards are improperly handled and can result in complete or intermittent failures. Do the following to prevent ESD:

- Always follow ESD prevention procedures when removing and replacing cards.
- Wear an ESD-preventive wrist strap, ensuring that it makes good skin contact. Connect the clip to an unpainted surface of the chassis frame to safely channel unwanted ESD voltages to ground.
- To properly guard against ESD damage and shocks, the wrist strap and cord must operate effectively. If no wrist strap is available, ground yourself by touching the metal part of the chassis.

## **2.0 GENERAL INFORMATION**

Thank you for your purchase of this Patton Electronics product. This product has been thoroughly inspected and tested and is warranted for one year for parts and labor. If any questions or problems arise during installation or use of this product, contact Patton Electronics Technical Support at +1 (301) 975-1007.

### **2.1 FEATURES**

- Variable rate CopperLINK extender - Easy to configure
- Auto-MDIX Ethernet
- Configurable 10/100, Full/Half, and Auto-Negotiating Ethernet
- Extends network connections up to 5,500 ft (1.6 km) over 2-wire 24-AWG unconditioned lines
- Auto-Rate line rates up to 100 Mbps downstream/70 Mbps upstream
- Symmetric or asymmetric settings via DIP switch
- Transparent operation
- LED indicators for Power, Link, Ethernet Link & Activity, and Remote/Local

### **2.2 DESCRIPTION**

The Patton Electronics Model 2173R Ruggedized Ethernet Extender provides high-speed LAN connections between peered Ethernet LANs, remote PCs, or any other network enabled 10/100Base-T device.

Operating in pairs, one Model 2173R or 2173 is configured as the (L) Local unit located at one end of the LAN extension and the other Model 2173R or 2173 is configured as the (R) Remote unit at the other end. These units can automatically forward LAN broadcasts, multicasts, and frames across a 2-wire voice-grade twisted-pair link. The data is passed transparently (unmodified) through the 2173Rs or 2173s. The 2173Rs automatically add and delete MAC addresses, only passing packets across the CopperLINK link that are meant for the remote peered LAN.



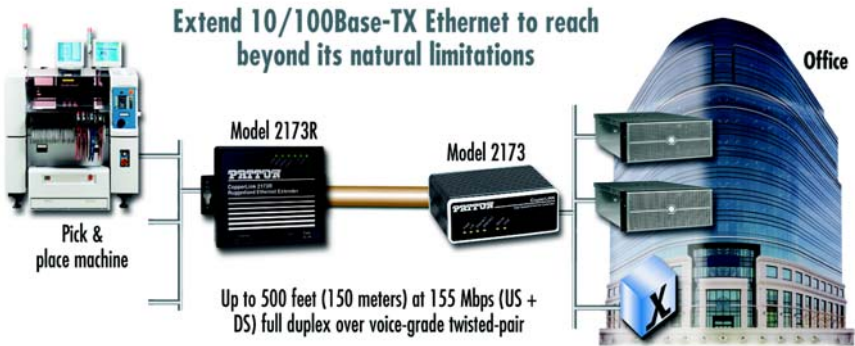

**Figure 1.** Typical application

The pair of 2173R and 2173 models work together to create a transparent extension between two peered Ethernet LANs. Figure 1 shows a typical point-to-point application.

### 3.0 INSTALLATION



**The interconnecting cables shall be acceptable for external use and shall be rated for the proper application with respect to voltage, current, anticipated temperature, flammability, and mechanical serviceability.**

To install the 2173R Ethernet Extender, do the following:

1. Connect the line interface between the units (refer to section 3.1, “Connecting the Twisted-Pair Line Interface” on page 10)

**Note** See Figure 2 for the standalone unit’s rear panel arrangements.

2. Connect the Ethernet interface (refer to section 3.2, “Connecting the 10/100Base-T Ethernet Interface” on page 11).
3. Connect the power plug (refer to section 3.3, “Connecting Power” on page 12).

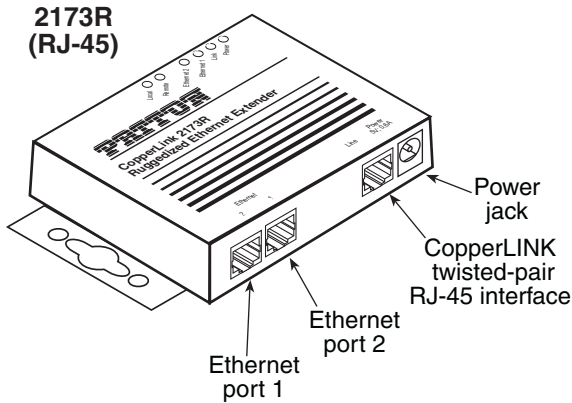

Figure 2. Model 2173R panel

### 3.1 CONNECTING THE TWISTED-PAIR LINE INTERFACE



**The interconnecting cables shall be acceptable for external use and shall be rated for the proper application with respect to voltage, current, anticipated temperature, flammability, and mechanical serviceability.**

The Model 2173R supports communication between two peer Ethernet LAN sites over a distance of up to 5,500 ft (1.6 km) over 24 AWG (0.5 mm) twisted-pair wire.

**Note** Actual distance and link performance may vary depending on the environment and type/gauge of wire used.

Follow the steps below to connect the Model 2173R CopperLINK Interfaces.

**Note** The Model 2173R units work in pairs. One of the units must be configured as a (L) Local unit, and the other unit must be configured as a (R) Remote unit. It does not matter which end is the L and which is the R. The link is always initiated by the R unit. As long as the L unit is powered on, the R unit can establish a link by being powered on or by having its power reset.

1. To function properly, the two Model 2173Rs must be connected together using twisted-pair, unconditioned, dry, metal wire, between 19 (0.9mm) and 26 AWG (0.4mm). Leased circuits that run through signal equalization equipment are not acceptable.

2. The Model 2173R is equipped with either an RJ-45 interface jack that can be used on the CopperLINK interface. These CopperLINK interfaces are a two-wire interface. Observe the signal/pin relationships on the Model 2173R's CopperLINK interface jacks.

The RJ-45 connector on the Model 2173R's twisted pair interface is polarity insensitive and is wired for a two-wire interface. The signal/pin relationship is shown in Figure 3.

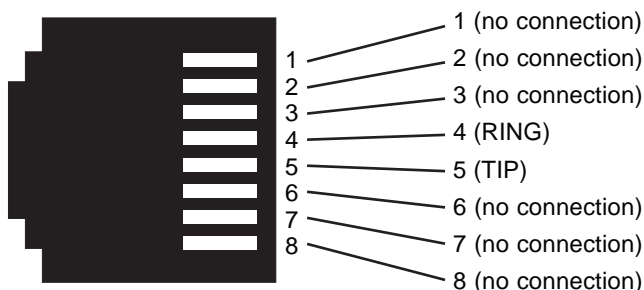

Figure 3. Model 2173R (RJ-45) twisted pair line interface.

### 3.2 CONNECTING THE 10/100BASE-T ETHERNET INTERFACE



**The Interconnecting cables shall be acceptable for external use and shall be rated for the proper application with respect to voltage, current, anticipated temperature, flammability, and mechanical serviceability.**

The shielded RJ-45 port labeled *Ethernet* is the Auto-MDIX10/100Base-T interface. This port is designed to connect directly to a 10/100Base-T network. Figure 4 shows the signal/pin relationships on this interface. You may connect this port to a hub or PC using a straight through or crossover cable that is up to 328 ft long.

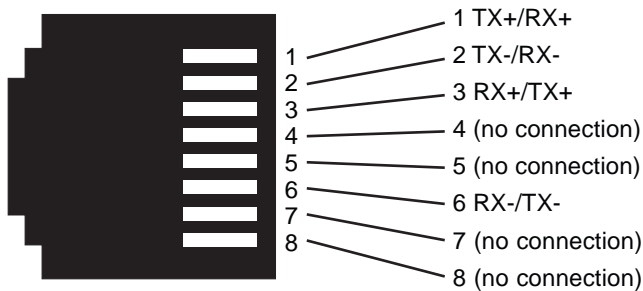

Figure 4. Model 2173R 10/100Base-T RJ-45 Connector Pinout.

### 3.3 CONNECTING POWER



The Interconnecting cables shall be acceptable for external use and shall be rated for the proper application with respect to voltage, current, anticipated temperature, flammability, and mechanical serviceability.

The Model 2173R does not have a power switch, so it powers up as soon as it is plugged in.

An external AC or DC power supply is available separately. This connection is made via the barrel jack on the rear panel of the Model 2173R. No configuration is necessary for the power supply (See Appendix B for domestic and international power supply and cord options).

DC power (supplied via the power supply jack to the 2173R) must meet the following requirements; DC power supplied must be regulated +5VDC  $\pm$ 5%, 1.0A minimum. Center pin is +5V. The barrel type plug has a 2.5/5.5/10mm I.D./O.D./Shaft Length dimensions.

## 4.0 CONFIGURATION

The Model 2173 has four DIP switches (S1) for configuring the unit for a wide variety of applications. This section describes switch locations and explains the different configurations..

### 4.1 CONFIGURING THE HARDWARE DIP SWITCHES

Using a small flat-tip screwdriver, remove the protective cover located on the underside of the Model 2173R (see Figure 5).

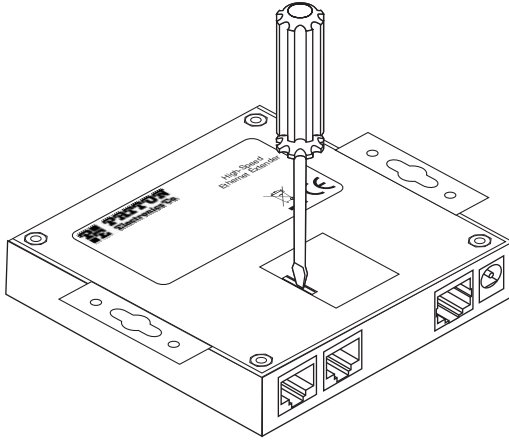

**Figure 5.** Removing protective cover

Figure 6 on page 13 shows the orientation of the DIP switches in the On and Off positions.

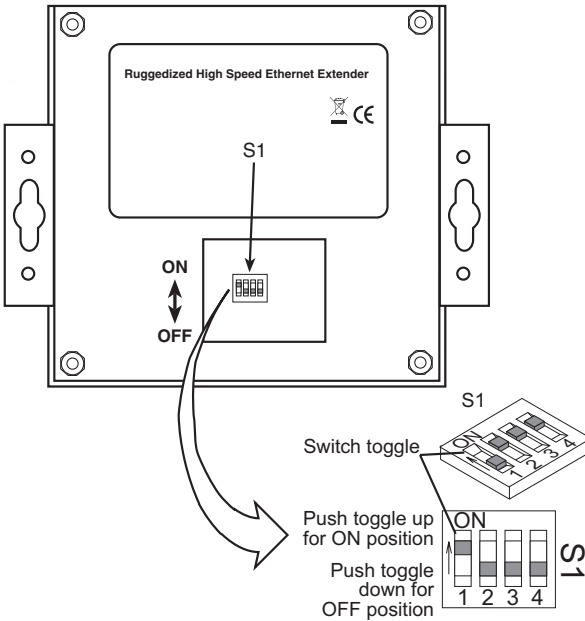

**Figure 6.** DIP switch orientation

## 4.2 CONFIGURING DIP SWITCH S1

DIP switch S1 is where you configure the CopperLINK line. The following tables describe the configuration for the 2173.

Table 1: 2173 Firmware Configuration

Position	S1-1	S1-2	S1-3	S1-4
	Master/Slave	Mode	Rate	SNR
ON	Slave (CPE)	Fast	Auto	6dB
OFF	Master (CO)	Interleave	25/25	9dB

### S1-2: Impulse Noise Protection

- **Fast Mode:** Direct data transmission with latency less than 1ms
- **Interleave Mode:** Provides data transmission protection for up to 250 ms impulse noise with latency less than 6 ms

### S1-3: Rate Limit

S1-3	Rate
OFF	25/25
ON	Auto

### S1-4: General Protection (Signal to Noise Ratio)

- **6dB:** Original line noise protection with 6dB SNR
- **9dB:** Better line noise protection with SNR up to 9dB

## 5.0 OPERATION

Once the Model 2173Rs are properly installed, they should operate transparently. No user settings required. This section describes reading the LED status monitors.

### 5.1 POWER UP

Before applying power to the Model 2173R, please review section 3.3, "Connecting Power" on page 12 to verify that the unit is connected to the appropriate power source.

## 5.2 FRONT PANEL LED STATUS MONITORS

The Model 2173R features six front panel LEDs that monitor power, the Ethernet signals, the CopperLINK connection, and the remote/local setting. Figure 7 shows the front panel location of each LED. Table 2 on page 15 describes the LED functions.

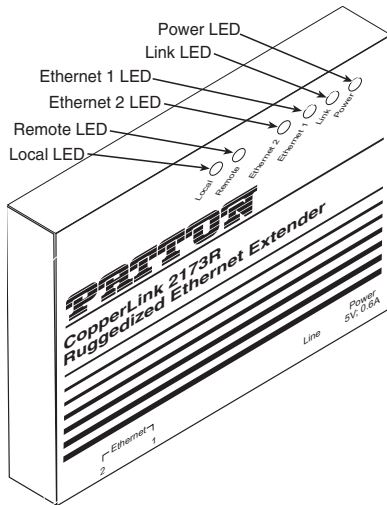

Figure 7. Model 2173R front panel

Table 2: Front panel LED description

LED	Status	Description
<b>Power</b>	Green	The device is powered on.
	Off	The device is powered off.
<b>CopperLink</b>	Green	The port is connected.
	Blinking Green	Data transceiving.
	Off	No valid link on this port.
<b>Ethernet</b>	Green	The port is connected.
	*Blinking Green	Data transceiving.
<b>Local</b>	Green	The device acts in Local mode.
	Off	Local mode is off.
<b>Remote</b>	Green	The device acts in Remote mode.
	Off	Remote mode is off.

\*. Once the unit connects to a power source, the Link LED will blink as the 2173R automatically looks for the other unit in the pair.

## **APPENDIX A**

### **SPECIFICATIONS**

#### **A.1 LAN CONNECTION**

- Two shielded RJ-45, 10/100Base-T, IEEE 802.3 Ethernet
- CopperLINK Connection: Shielded RJ-45

#### **A.2 TRANSMISSION LINE**

Two-wire unconditioned twisted pair.

#### **A.3 COPPERLINK LINE RATE AND COPPERLINK DISTANCE**

- Line Rate: Up to 155 Mbps aggregate (upstream/downstream) via Auto Rate; and 25/25 Mbps via DIP switch settings.
- Distance: Up to 5,500 ft (1.6 km)

**Note** Distances depend on line rate and line conditions.

#### **A.4 LED STATUS INDICATORS**

- Power (Green)
- CopperLINK: Link (Green)
- Ethernet: Link (Green) & Activity (Flashing Green)
- Remote (Green)
- Local (Green)

#### **A.5 POWER SUPPLY**

External AC and DC options:

- AC: 120 VAC, 220 VAC, and UI (120–240 VAC)
- DC: 12 VDC, 24 VDC and 48 VDC
- Power consumption: 860mA at 5V

#### **A.6 TEMPERATURE RANGE**

-40 to 85°C

#### **A.7 HUMIDITY**

**Standard:**Up to 90% non-condensing

#### **A.8 DIMENSIONS**

1.5H x 4.13W x 3.75D in.(3.81H x 10.5W x 9.53D cm)



**APPENDIX B**  
**MODEL 2173R FACTORY**  
**REPLACEMENT PARTS AND ACCESSORIES**

Patton Model #	Description
<b>Base Models</b>	
2173R/E	CopperLINK Multi Rate 100 Mbps Ethernet Extender; No power supply
2173R/E-2PK	CopperLINK Multi Rate 100 Mbps Ethernet Extender Kit (2 units preset to local and remote); No power supply
2173R/EUI-2PK	CopperLINK Multi Rate 100 Mbps Ethernet Extender Kit (2 units preset to local and remote); 110-240VAC
07M2173R-UM	User Manual
<b>Power Supplies</b>	
08055DCUI	100-240VAC (+5V reg. DC/2A) Universal Input Adapter.
08055-120-5-1	120 VAC (+5V reg. DC/1A) Input Adapter
12V-PSM	12 VDC Input Adapter
24V-PSM	24 VDC Input Adapter
48V-PSM	48 VDC Input Adapter
<b>Power Cords*</b>	
0805US	American Power Cord
0805EUR	European Power Cord CEE 7
0805UK	United Kingdom Power Cord
0805AUS	Australian Power Cord
0805DEN	Denmark Power Cord
0805FR	France/Belgium Power Cord
0805IN	India Power Cord
0805IS	Israel Power Cord
0805JAP	Japan Power Cord
0805SW	Switzerland Power Cord

\*Only required with optional UI power supply (08055DCUI)

**APPENDIX C**  
MODEL 2173R INTERFACE PIN ASSIGNMENT

**C.1 10/100BASE-T INTERFACE**

**RJ-45**

- Pin 1: TX+
- Pin 2: TX-
- Pin 3: RX+
- Pin 6: RX-
- Pins 4, 5, 7, 8: no connection

**C.2 COPPERLINK INTERFACE**

**RJ-45**

- Pin 4: RING
- Pin 5: TIP
- Pins 1, 2, 3, 6, 7, 8: no connection

## APPENDIX D

SAMPLE RATES/DISTANCE CHART, BASED ON 24 AWG (0.5 MM)

Rate	Mode	Distance in Feet (km)	Throughput at Max Distance (megabits per second)
4/1	Fast	5,500 (1.6 km)	4.00 (DS) 1.00 (US)
4/1	Interleave	5,500 (1.6 km)	4.00 (DS) 1.00 (US)
100/70	Fast	500 ft (0.15 km)	83 (DS) 69.5 (US)
100/70	Interleave	250 (0.07 km)	83 (DS) 69.5 (US)
25/25*	Interleave	2,250 (0.6 km)	24.89 (DS) 24.89 (US)
50/50	Fast	1,750 (0.5 km)	49.78 (DS) 49.78 (US)
50/50	Interleave	1,750 (0.5 km)	49.78 (DS) 49.78 (US)
70/70	Fast	1,750 (0.5 km)	51 (DS) 51 (US)
70/70	Interleave	1,750 (0.5 km)	51 (DS) 51 (US)

\*. For the 25/25 rate, set S1-3 to the OFF position.

**Note** The actual distance and link performance may vary depending on the environment and type/gauge of wire used.

**Note** DS = downstream, US = upstream

Copyright © 2012  
Patton Electronics Company  
All Rights Reserved.