

See **Chapter 2** for installation procedures & **Chapter 3** for configuration procedures

PATTON
Let's Connect![™]

Model 2616RC **T1/E1 TDM-Digital Access Concentrator (T-DAC)**

User Manual

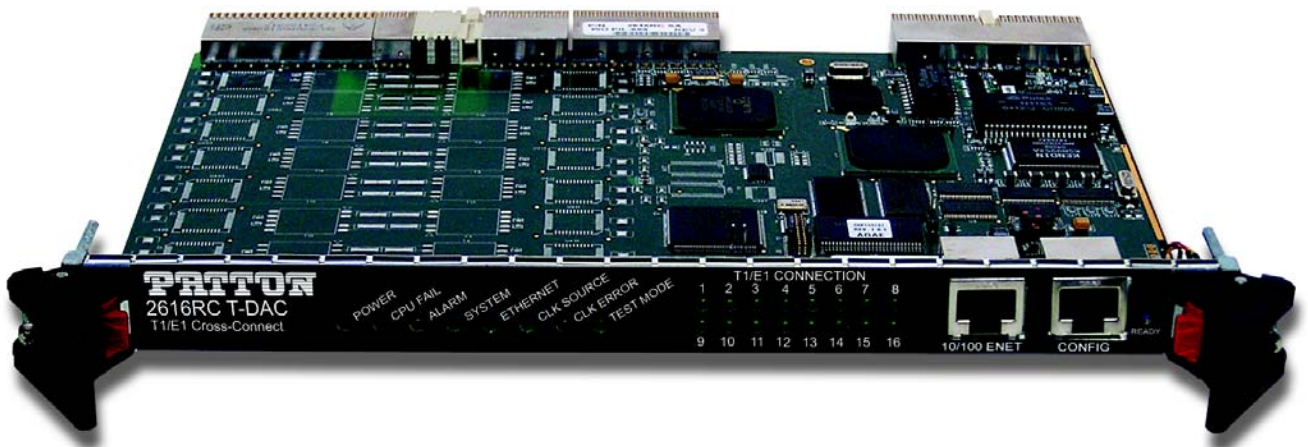

Important

This is a Class A device and is intended for use in a light industrial environment. It is not intended nor approved for use in an industrial or residential environment.

Sales Office: **+1 (301) 975-1000**
Technical Support: **+1 (301) 975-1007**
E-mail: **support@patton.com**
WWW: **www.patton.com**

Part Number: **07MD2616RC-GSG, Rev. E**
Revised: **February 16, 2012**

Patton Electronics Company, Inc.

7622 Rickenbacker Drive
Gaithersburg, MD 20879 USA
Tel: +1 (301) 975-1000
Fax: +1 (301) 869-9293
Support: +1 (301) 975-1007
Web: www.patton.com
E-Mail: support@patton.com

Copyright © 2012, Patton Electronics Company. All rights reserved.

The information in this document is subject to change without notice. Patton Electronics assumes no liability for errors that may appear in this document.

Warranty Information

The software described in this document is furnished under a license and may be used or copied only in accordance with the terms of such license.

Patton Electronics warrants all Model 2616RC components to be free from defects, and will—at our option—repair or replace the product should it fail within one year from the first date of the shipment.

This warranty is limited to defects in workmanship or materials, and does not cover customer damage, abuse or unauthorized modification. If the product fails to perform as warranted, your sole recourse shall be repair or replacement as described above. Under no condition shall **Patton Electronics** be liable for any damages incurred by the use of this product. These damages include, but are not limited to, the following: lost profits, lost savings and incidental or consequential damages arising from the use of or inability to use this product. **Patton Electronics** specifically disclaims all other warranties, expressed or implied, and the installation or use of this product shall be deemed an acceptance of these terms by the user.

Summary Table of Contents

- 1 Introduction 13
- 2 Hardware installation 19
- 3 Configuring the T-DAC for operation 31
- 4 Operation and shutdown 58
- 5 Troubleshooting and maintenance 60
- 6 Contacting Patton for assistance 72
- A Compliance information 75
- B 68-pin SCSI-to-open-end 6-foot cable (part #10-3096TM68-6) 78

Contents

About this guide	10
Audience.....	10
Structure.....	10
Precautions	11
Typographical conventions used in this document.....	12
General conventions	12
Mouse conventions	12
1 Introduction	13
Model 2616RC T1/E1 T-DAC overview	14
Hardware overview	15
WAN	15
LAN	15
RS-232 control port	16
Power system	16
Central processing unit	16
System timing	16
Temperature	16
Altitude	16
Humidity	16
Physical dimensions	16
Management services	16
LED display	18
2 Hardware installation	19
Introduction.....	20
Unpacking the Model 2616RC T-DAC.....	20
T-DAC blades installation.....	20
Cable installation.....	22
Connecting the Ethernet ports	22
Connecting the 10/100Base-T Ethernet port to an Ethernet switch or hub	22
Connecting the 10/100Base-T Ethernet port to an Ethernet-capable workstation or PC	23
Connecting the EIA-561 RS-232 configuration port (DCE configured)	23
Connecting the T1/E1 WAN ports	24
68-pin SCSI to 8 RJ-45 connectors cable	24
68-pin SCSI to open end cable	26
Installing the WAN cable to a punch-down block	28
68-pin SCSI to open end, 6 foot cable (part #10-3096TM68-6)—Obsolete	29
68-pin SCSI to 64-pin female Telco (part #10-3096TM68/64-6)	29
Completing the hardware installation	30
3 Configuring the T-DAC for operation	31

Introduction	32
Configuration prerequisites	32
Initial configuration through the RS-232 control port.....	33
Connecting the DB9-RJ45 adapter with the included cable	33
Setting up the HyperTerminal (or similar program) session	34
Using a browser to complete Model 2616RC configuration	37
Displaying the T-DAC 2616RC web administration pages	38
Home page overview	38
Configuring the default gateway	40
Configuring the system clocking parameters	41
Configuring the DS0 mapping	44
Configuring line settings and signaling for E1	46
Accessing the Line Interface Settings	46
Configuring the E1 line interface settings	47
Configuring line settings and signaling for T1	49
Accessing the Line Interface Settings	49
Configuring the T1 line settings	50
Enabling/disabling the alarm card	52
Saving your configuration.....	53
Backing up your configuration parameters.....	53
Backing up the configuration store in flash memory	55
Completing the installation	56
4 Operation and shutdown.....	58
Introduction.....	59
Activating the Model 2616RC.....	59
De-activating the Model 2616RC	59
5 Troubleshooting and maintenance	60
Introduction.....	61
Fault analysis	62
T1/E1 port test modes.....	64
DSX1 payload loop (dsx1PayloadLoop)	64
DSX1 line loop (dsxLineLoop)	65
Periodic maintenance	66
Calibration	66
Maintenance.....	66
Exporting the current Model 2616RC configuration	66
Removing the defective Model 2616RC	69
Installing the replacement Model 2616RC	70
Importing a saved configuration	70
Completing the installation	71
6 Contacting Patton for assistance	72
Introduction.....	73
Contact information.....	73

Warranty Service and Returned Merchandise Authorizations (RMAs)73

 Warranty coverage73

 Out-of-warranty service73

 Returns for credit73

 Return for credit policy74

 RMA numbers74

 Shipping instructions74

A Compliance information 75

 Compliance76

 EMC76

 Safety76

 PSTN Regulatory76

 Radio and TV Interference76

 Industry Canada Notice76

 FCC Part 68 (ACTA) Statement77

 CE Declaration of Conformity77

 Authorized European Representative77

B 68-pin SCSI-to-open-end 6-foot cable (part #10-3096TM68-6) 78

 Introduction79

List of Figures

1	Model 2616RC T-DAC	14
2	Model 2616RC T-DAC features	15
3	Model 2616RC front panel LEDs	17
4	Alignment/ESD pin and card handle	21
5	Model 2616RC network and configuration ports	22
6	Ethernet RJ-45 pin and signal definitions for T-DAC	23
7	Cross-over RJ-45-to-RJ-45 Ethernet cable diagram	23
8	DB-9-to-RJ-45 cable diagram	23
9	SCSI-to-RJ45 6-foot WAN cable	24
10	WAN cable's 68-pin SCSI connector	25
11	RJ-45 plug	25
12	SCSI-to-open-end WAN cable	26
13	68-pin SCSI connector	26
14	Punch-down block wiring	28
15	SCSI-to-open-end 6-foot WAN cable (obsolete)	29
16	Model 2616RC interface ports	33
17	Connection Description window	34
18	Connect To window	34
19	COM1 Properties window	35
20	Terminal keys configuration	35
21	Login window	36
22	VT-100 top level management window	36
23	Ethernet configuration window	37
24	2616RC Configuration Menu home page	38
25	HOME page window panes	39
26	Operator Actions buttons	39
27	IP Routing Information Page	40
28	IP Routing Information window	41
29	System Clocking Configuration page, example 1	42
30	System Clocking Configuration page, example 2	43
31	Clock Reference Submit Query button	43
32	Clock Reference Submit Query button	43
33	DS0 Mapping Overview window	44
34	Display Option menu	44
35	T1/E1 Link Activity Overview page	46
36	T1/E1 Link Activity Ports 1 – 4 page.	47
37	WAN Circuit Configuration page, Line Interface Settings	47
38	Line Type pull-down menu	48
39	Line Coding pull-down menu with dsx1HDB3(3) selected	48
40	Line Build Out pull-down menu with e1pulse(1) selected	48
41	E1 ALARMS PRESENT indicator	49
42	T1/E1 Link Activity Overview page	49
43	T1/E1 Link Activity Ports 1 – 4 page.	49
44	WAN Circuit Configuration page, Line Interface Settings	50
45	Line Type pull-down menu with dsx1ESF(2) selected	50
46	Line Coding pull-down menu with dsx1B8ZS(2) selected	51
47	Line Build Out pull-down menu with t1pulse0dB(1) selected	51

48	T1 ALARMS PRESENT indicator on T1/E1 LINK ACTIVITY page	51
49	Alarm Card Information window	52
50	2616RC Configuration Menu home page	53
51	IMPORT/EXPORT page	54
52	Example T-DAC flash memory configuration file displayed in a browser	55
53	Saving the access server flash memory configuration data as a text file	56
54	Payload loopback	64
55	Line Loop	65
56	IMPORT/EXPORT page	67
57	Example T-DAC flash memory configuration file displayed in a browser	68
58	Saving the access server flash memory configuration data as a text file	69

List of Tables

- 1 General conventions 12
- 2 Mouse conventions 12
- 3 LED definitions 18
- 4 RJ-45 plug pin-out 25
- 5 WAN cable's 68 non-terminated twisted-pairs 27
- 6 Symptoms 61
- 7 LED definitions 62
- 8 WAN cable's 68 non-terminated twisted-pairs 79

About this guide

This guide describes installing and configuring a Patton Electronics Model 2616RC TDM-Digital Access Concentrator (T-DAC). By the time you are finished with this guide, your T-DAC will be connected to T1/E1 lines and transferring data. The instructions in this guide are based on the following assumptions:

- The T-DAC will connect to T1/E1 lines
- There is a LAN connected to the Ethernet port of the T-DAC

Audience

This guide is intended for the following users:

- Operators
- Installers
- Maintenance technicians

Structure

This guide contains the following chapters and appendices:

- Chapter 1 describes the T-DAC
- Chapter 2 describes installing the T-DAC hardware
- Chapter 3 describes configuring the T-DAC for use
- Chapter 4 details how to power up and deactivate the T-DAC
- Chapter 5 contains troubleshooting and maintenance information
- Chapter 6 contains information on contacting Patton technical support for assistance

For best results, read the contents of this guide *before* you install the T-DAC.

Precautions

Notes and cautions, which have the following meanings, are used throughout this guide to help you become aware of potential T-DAC problems. *Warnings* relate to personal injury issues, and *Cautions* refer to potential property damage.

Note Calls attention to important information.



The shock hazard symbol and **WARNING** heading indicate a potential electric shock hazard. Strictly follow the warning instructions to avoid injury caused by electric shock.



The alert symbol and **WARNING** heading indicate a potential safety hazard. Strictly follow the warning instructions to avoid personal injury.



The shock hazard symbol and **CAUTION** heading indicate a potential electric shock hazard. Strictly follow the instructions to avoid property damage caused by electric shock.



The alert symbol and **CAUTION** heading indicate a potential hazard. Strictly follow the instructions to avoid property damage.

Safety when working with electricity



- The Model 2616RC shall be installed in a restricted access location accessible only to authorized personnel.
- This unit contains no user-serviceable parts. Refer servicing to qualified personnel.
- When removing cards from a shelf under power, some of the components such as the DC converters may be extremely hot. Handle by the card guides only.
- To prevent accidental electrical short circuits, align the card correctly between the card guides before you insert it in the slot.



In accordance with the requirements of council directive 2002/96/EC on Waste of Electrical and Electronic Equipment (WEEE), ensure that at end-of-life you separate this product from other waste and scrap and deliver to the WEEE collection system in your country for recycling.

Typographical conventions used in this document

This section describes the typographical conventions and terms used in this guide.

General conventions

The procedures described in this manual use the following text conventions:

Table 1. General conventions

Convention	Meaning
Garamond blue type	Indicates a cross-reference hyperlink that points to a figure, graphic, table, or section heading. Clicking on the hyperlink jumps you to the reference. When you have finished reviewing the reference, click on the Go to Previous View button  in the Adobe® Acrobat® Reader toolbar to return to your starting point.
Futura bold type	Indicates the names of menu bar options.
<i>Italicized Futura type</i>	Indicates the names of options on pull-down menus.
Futura type	Indicates the names of fields or windows.
Garamond bold type	Indicates the names of command buttons that execute an action.
< >	Angle brackets indicate function and keyboard keys, such as <SHIFT>, <CTRL>, <C>, and so on.
Are you ready?	All system messages and prompts appear in the Courier font as the system would display them.
% dir *.*	Bold Courier font indicates where the operator must type a response or command

Mouse conventions

The following conventions are used when describing mouse actions:

Table 2. Mouse conventions

Convention	Meaning
Left mouse button	This button refers to the primary or leftmost mouse button (unless you have changed the default configuration).
Right mouse button	This button refers the secondary or rightmost mouse button (unless you have changed the default configuration).
Point	This word means to move the mouse in such a way that the tip of the pointing arrow on the screen ends up resting at the desired location.
Click	Means to quickly press and release the left or right mouse button (as instructed in the procedure). Make sure you do not move the mouse pointer while clicking a mouse button.
Double-click	Means to press and release the same mouse button two times quickly
Drag	This word means to point the arrow and then hold down the left or right mouse button (as instructed in the procedure) as you move the mouse to a new location. When you have moved the mouse pointer to the desired location, you can release the mouse button.

Chapter 1 Introduction

Chapter contents

- Model 2616RC T1/E1 T-DAC overview14
- Hardware overview15
 - WAN15
 - LAN15
 - RS-232 control port16
 - Power system16
 - Central processing unit16
 - System timing16
 - Temperature16
 - Altitude16
 - Humidity16
 - Physical dimensions16
 - Management services16
 - LED display18

Model 2616RC T1/E1 T-DAC overview

The Model 2616RC (see [figure 1](#)) provides 16 T1/E1 ports. A built-in digital cross-connect switch provides completely flexible grooming; the capability to connect any DS0-channel to any other DS0-channel from the WAN uplink ports or the T1/E1 ports. The T-DAC combines a time-slot multiplexer and a centralized web-based management system on a front and rear blade for insertion in a Patton ForeFront chassis with a chassis mid-plane architecture. The front blade contains LED status indicators, an RS-232 configuration port and a 10/100 Ethernet management port. The rear blade contains the T1/E1 WAN port connections. The 16 T1/E1 ports connect to channelized T1 or E1 network connections.

Each WAN port terminates T1/E1 with flexible any-to-any DS0 mapping. The entire system can be managed in-band (via T1/E1 Frame Relay/PPP links) or out-of-band from a web browser by means of SNMP/HTTP-based management screens.

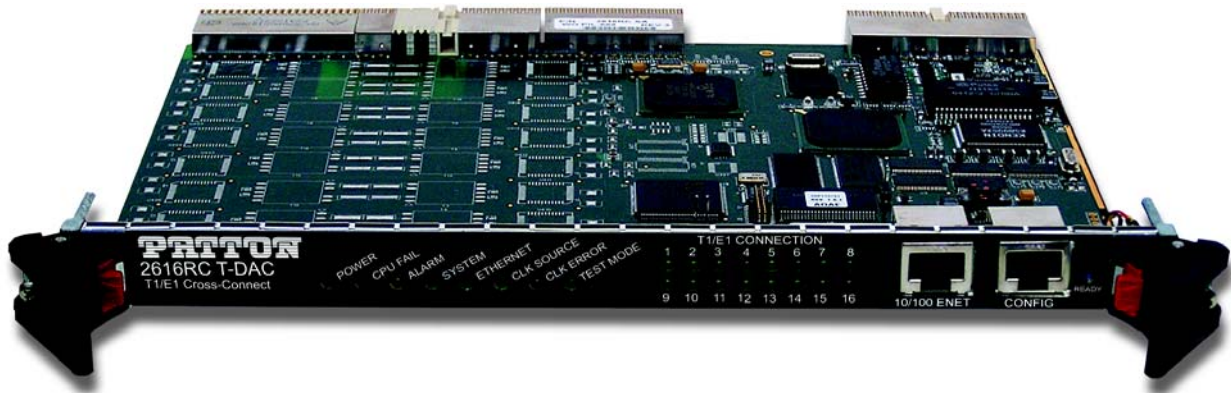

Figure 1. Model 2616RC T-DAC

Hardware overview

The Model 2616RC combines transmission and networking technology concentrating 16 T1/E1 WAN links into a single slot blade for a Patton ForeFront chassis. The T-DAC front blade (see [figure 2](#)) contains a full set of LED status indicators presented on the front panel, and an RS-232 async control port. The rear blade presents electrical connections for T1/E1 WAN ports as well as an alarm LED.

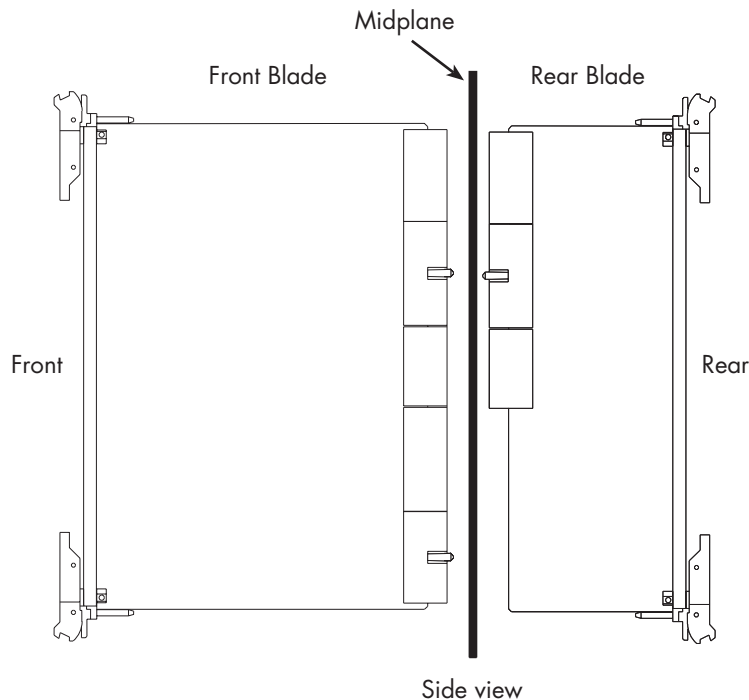

Figure 2. Model 2616RC T-DAC features

WAN

The 2616RC includes 4, 8, 12, or 16 ports selectable for T1 or E1 operation. The T1/E1 ports may be connected to ATM/FR/DDN/IP network backbones and are accessible via the 68-pin SCSI connector in the rear of the unit. Also included are:

- 4 to 16 built-in T1/E1 CSU/DSUs
- T1 1.544 Mbps with D4 or ESF framing, AMI or B8ZS line coding, FCC part 68 compliant
- E1 2.048 Mbps multi-framing with or without CRC4 framing, AMI/HDB3 line coding, CTR-12, and CTR-13 compliant
- Built-in fuses and surge protectors

LAN

The 10/100-Mbps Ethernet LAN port is presented on an RJ-45 connector with an auto-sensing/full-duplex 10Base-T or 100Base-T interface. Also included are:

- 100Base-TX half-/full-duplex operation (100 + 100)

- 10Base-T half-/full-duplex operation (10 + 10)
- Auto detection and fallback
- 10/100 Mbps link and status indicators

RS-232 control port

The RS-232 port provides for initial configuration of the Model 2616RC. The RS-232 port supports:

- Asynchronous data rates of 19.2 kbps, 8 data bits, no parity, 1 stop bit.
- An RJ-45 connector with EIA-561 pinouts
- A management interface that supports VT-100 terminals
- Hardware flow control (RTS and CTS)

Power system

The 2616RC obtains power from the Patton ForeFront chassis. Total power consumption is a maximum of 43 watts provided by modular power supplies installed in the Patton ForeFront chassis.

Central processing unit

The 2616RC employs an Intel i960VH RISC processor operating at 100 MHz/100 Mips. The CPU controls the memory, front/back-panel and management interface for WAN time slot mapping, local switching, loop-back and the management system. The memory holds:

- 4 MB Flash ROM
- 8 MB EDO DRAM

System timing

The T1/E1 T-DAC's system timing may be derived from an internal clock from an on-board chip, external BITS clock, or a network clock from one of the T1/E1 WAN ports or from the ForeFront system chassis clock. The clock source may be configured in primary, secondary, or slave mode.

The system timing is configured through the NMS.

Temperature

Operating range: 32–122°F (0–50°C)

Altitude

Maximum operating altitude: 15,000 feet (4,752 meters)

Humidity

5 to 95% relative humidity (RH), non-condensing

Physical dimensions

- 1.75 inches (4.44 cm) height, standard 19-inch (48.26 cm) width, 12-inch (30.48 cm) depth

Management services

- Out-of-Band RS-232 configuration port for management and control

- SNMP version 1 configuration management
- MIB II
- TELNET via Ethernet
- SYSLOG Client
- Remote Software Upgrade via FTP
- Built-in HTTP server for complete configuration and control using a standard web browser
- Frame Relay or PPP in-band management via T1/E1 DS0s.

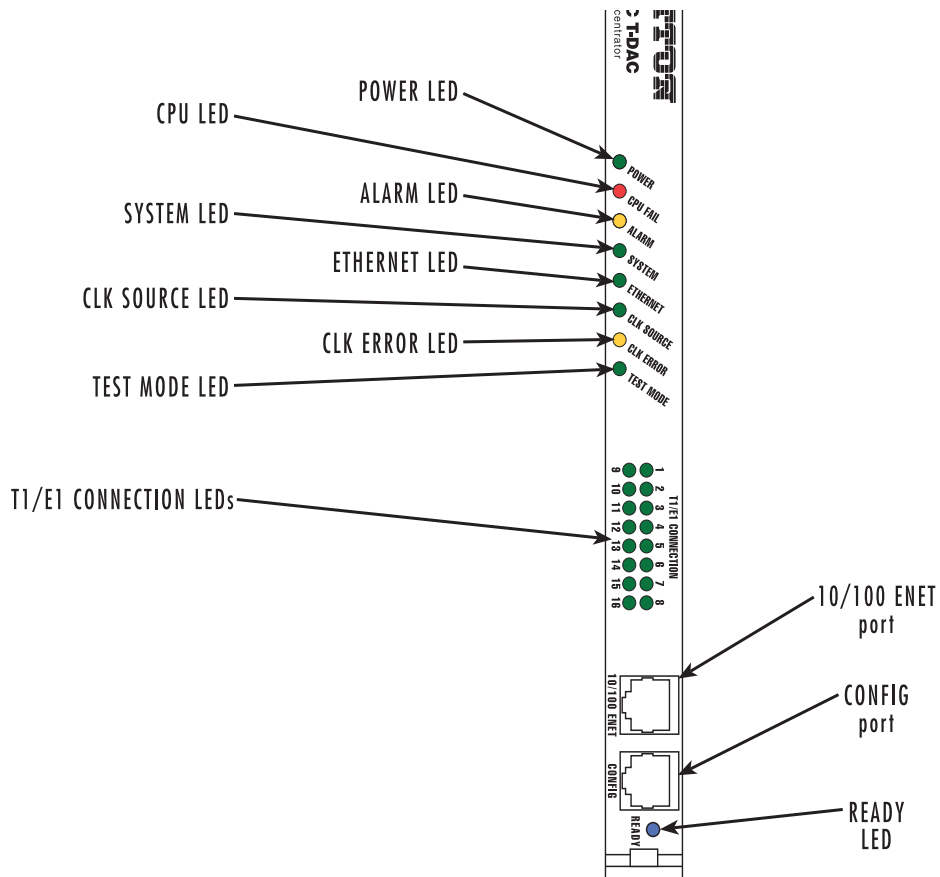

Figure 3. Model 2616RC front panel LEDs

LED display

Front panel LEDs (figure 3 on page 17) display the status of the WAN ports, the T1/E1 ports, the Ethernet LAN port, power, and the alarms. The LEDs are described in table 3.

Table 3. LED definitions

LED	Color	Status	Meaning
POWER	Green	On solid	Power is being applied. No action recommended.
		Flashing	The 2616RC has detected a power failure on a power bus.
		Off	No input power is being applied.
CPU FAIL	Red	On solid	CPU is unable to load the software from FLASH to RAM for operation.
		Off	The CPU is operating normally.
ALARM	Yellow	On solid	A minor alarm condition has been detected.
		Flashing	A major alarm condition has been detected.
		Off	The Model 2616RC is operating normally.
SYSTEM	Green	Flashing	The Model 2616RC is operating normally.
		Off	The Model 2616RC is not functioning properly.
ETHERNET	Green	On solid	Link status is nominal for the Ethernet port. No action recommended.
		Off	A valid link has not been detected.
CLK SOURCE	Green	On solid	The 2616RC is set as the Master Clock source.
		Flashing	The 2616RC is set as the secondary clock source.
		Off	The 2616RC is set as the slave, getting its clock from the H.110 Bus.
CLK ERROR	Yellow	On solid	Master Clock source has been lost and the 2616RC is using the secondary source for its clock.
		Flashing	Master Clock source and the Secondary Clock source have been lost and the 2616RC is using its internal crystal for its clock.
		Off	No clock errors currently detected.
TEST MODE	Green	On solid	One or more T1/E1 ports or T1/E1 ports is in test mode.
		Flashing	One or more of the T1/E1 ports or the T1/E1 ports is in test mode and errors have been received.
		Off	None of the T1/E1 ports is operating in test mode.
T1/E1 CONNECTION (LEDs 1–16)	Green	On solid	The port is activated, linked, and operating normally.
		Flashing	The port is activated but not linked or in an error state.
READY	Blue	On	Card ready for removal from Patton ForeFront chassis.
		Off	Card not ready for removal from Patton ForeFront chassis.

Chapter 2 **Hardware installation**

Chapter contents

Introduction.....	20
Unpacking the Model 2616RC T-DAC.....	20
T-DAC blades installation.....	20
Cable installation.....	22
Connecting the Ethernet ports	22
Connecting the 10/100Base-T Ethernet port to an Ethernet switch or hub	22
Connecting the 10/100Base-T Ethernet port to an Ethernet-capable workstation or PC	23
Connecting the EIA-561 RS-232 configuration port (DCE configured)	23
Connecting the T1/E1 WAN ports	24
68-pin SCSI to 8 RJ-45 connectors cable	24
68-pin SCSI to open end cable	26
Installing the WAN cable to a punch-down block	28
68-pin SCSI to open end, 6 foot cable (part #10-3096TM68-6)—Obsolete	29
68-pin SCSI to 64-pin female Telco (part #10-3096TM68/64-6)	29
Completing the hardware installation	30

Introduction

This chapter contains the following procedures for installing the Model 2616RC T-DAC:

Note Before installing the T-DAC, you will need to obtain the line type and encoding of the T1/E1 line from your local telephone company (Telco).

- “Unpacking the Model 2616RC T-DAC”—lists the contents in the T-DAC shipping container
- “T-DAC blades installation”—describes installing the T-DAC on a flat surface or in a standard 19-inch rack
- “Cable installation” on page 22—describes installing the power and network interface cables
- “Completing the hardware installation” on page 30—describes testing the T-DAC hardware to verify that it is ready for software configuration

Unpacking the Model 2616RC T-DAC

Inspect the shipping carton for external damage. Note any damage before removing the container contents. Report equipment damage to the shipping carrier immediately for claim purposes. Save all packing materials in case you need to return an item to the factory for servicing.

The T-DAC comes with the following items:

- The Model 2616RC Digital Cross-Connect (T-DAC)
- One RJ45-to-RJ45 cable for use with the console and Ethernet ports
- A DB9-RJ45 (EIA-561) adapter for connecting a PC's serial port to the T-DAC console port
- Model 2616RC T-DAC User Manual

T-DAC blades installation

Do the following:

Note Verify that the rack chassis is properly grounded before installing the T-DAC blades. An adequate ground can be achieved by connecting a #10 AWG ground wire between the rack chassis grounding stud and one of the following ground sources:

- The building ground rod (generally located at the site's main service entrance)
- A sprinkler system pipe
- A cold-water pipe
- Building structural steel

1. If you have not done so already, remove the T-DAC from its shipping container.

Note Be sure to wear the anti-static strap to prevent electrostatic damage to the blade.

Note The T-DAC should be installed as close as possible to the termination jack provided by the Telco. The location should be well ventilated. Do not block the rack chassis' cooling vents.

2. Insert the rear blade into the desired slot in the rack chassis. Make sure the blade is seated properly in the slot guides.

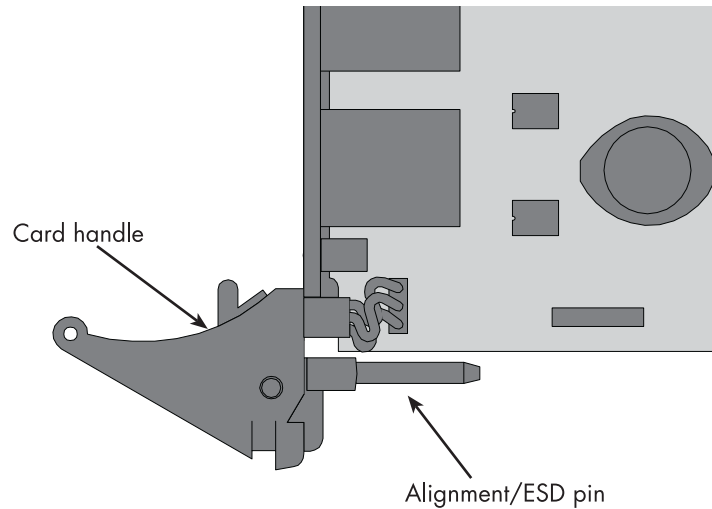

Figure 4. Alignment/ESD pin and card handle

3. Gently press the blade into the chassis until the alignment/ESD pin (see [figure 4](#)) engages the chassis. When the blade is fully seated, the red buttons in the handles click up automatically, thus locking the handle and activating the switch (closed position). The click of the button gives a visual and audible confirmation that the board is fully seated.
4. Insert the front blade into the rack chassis slot that corresponds to the slot in which you installed the rear blade. Verify that the buttons in both handles click up to indicate that the board is fully seated and locked into place.

Cable installation

This section describes installing the network interface cables.

Connecting the Ethernet ports

The T-DAC has a single 10/100 Ethernet interface for connection to your LAN (figure 5). The Ethernet port will autosense the correct speed of the local LAN and automatically negotiate half or full-duplex operation. This section describes connecting the T-DAC to the Ethernet LAN via an Ethernet hub, switch, or workstation.

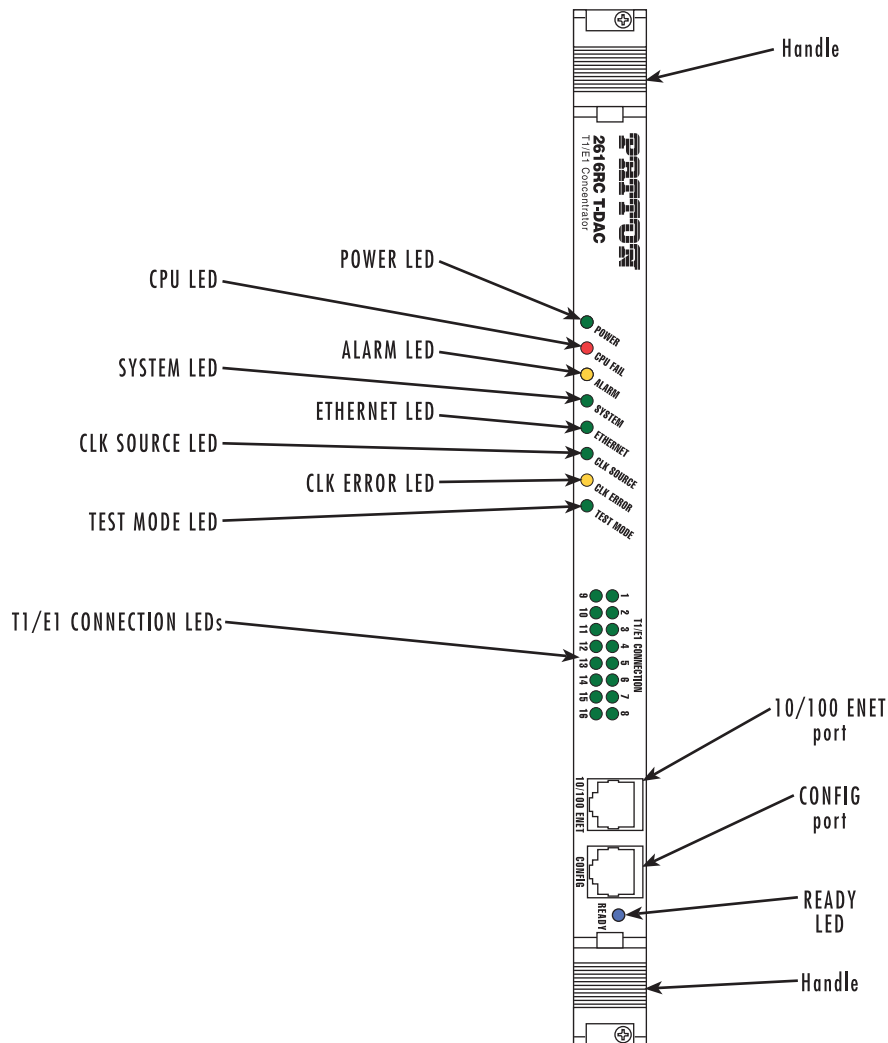

Figure 5. Model 2616RC network and configuration ports

Connecting the 10/100Base-T Ethernet port to an Ethernet switch or hub

The 10/100Base-T Ethernet port (see figure 5) is designed to connect to an Ethernet switch or hub. The Ethernet RJ-45 pin and signal definitions for the T-DAC or for a NIC card in a workstation/PC are shown in figure 6 on page 23. Connect a straight-through CAT-5 cable (one wired as shown in figure 6) between the T-DAC and the hub/switch.

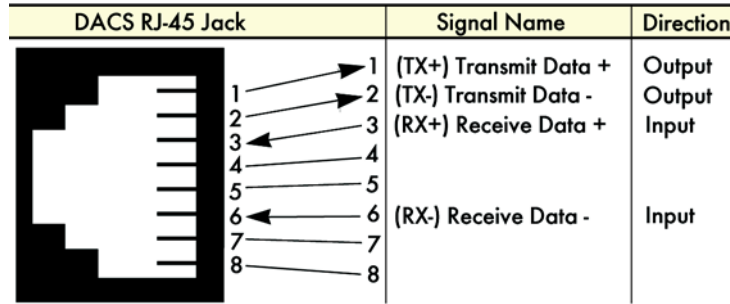

Figure 6. Ethernet RJ-45 pin and signal definitions for T-DAC

Connecting the 10/100Base-T Ethernet port to an Ethernet-capable workstation or PC

The 10/100Base-T Ethernet port can connect to a single Ethernet-capable workstation or PC by means of a cross over cable. Refer to figure 7 to assemble a cross-connect cable that will connect between the NIC Ethernet port in the workstation and the T-DAC 10/100Base-T Ethernet port.

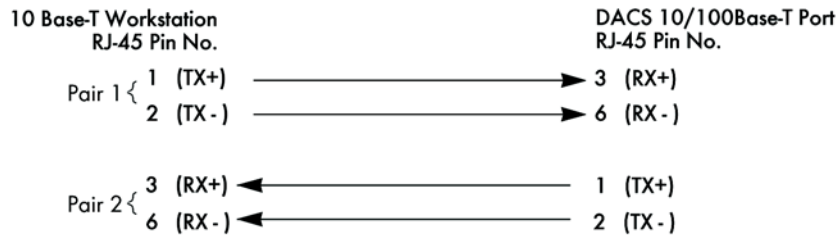

Figure 7. Cross-over RJ-45-to-RJ-45 Ethernet cable diagram

Connecting the EIA-561 RS-232 configuration port (DCE configured)

Install the supplied RJ-45-to-RJ-45 cable with the DB9-RJ45 adapter between the T-DAC RS-232 port (see figure 5 on page 22) and an open serial port on your computer. If you need to assemble your own cable, refer to the pinout diagram in figure 8.

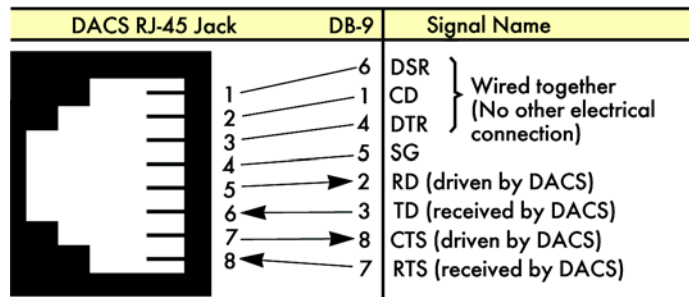

Figure 8. DB-9-to-RJ-45 cable diagram

Connecting the T1/E1 WAN ports

An active T1/E1 is not necessary to configure the T-DAC. However, active T1/E1 connections are required when mapping WAN time slots to other WAN time slots. The factory-set default configuration of the Model 2616RC has the T1/E1 ports disabled.

The following types of cables can be used to connect the 2616RC to T1/E1 lines:

- 68-pin SCSI to 8 RJ-45 connectors cable, 6 foot (1.8 m) (part #10-3096TM68/8RJ45-6) (see section “68-pin SCSI to 8 RJ-45 connectors cable” for installation details)
- 68-pin SCSI to 16 RJ-45 connectors cable, 6 foot (1.8 m) (part #10-3096TM68/16RJ45-6) (see section “68-pin SCSI to 8 RJ-45 connectors cable” for installation details)
- 68-pin SCSI to open end, 12 foot (3.6 m) (part #10-3096TM68-12) (see section “68-pin SCSI to open end cable” for installation details)

68-pin SCSI to 8 RJ-45 connectors cable

The SCSI-to-RJ-45 cable (see [figure 9](#)) connects to the 2616RC via a male SCSI connector (see [figure 10](#)). At the other end of the cable, T1/E1 lines terminate on 8 or 16 individual RJ-45 connectors (wired as RJ-48C) (see [figure 9](#)). Each RJ-45 terminated T1/E1 line connects directly to a local patch panel or to another T1/E1 device.

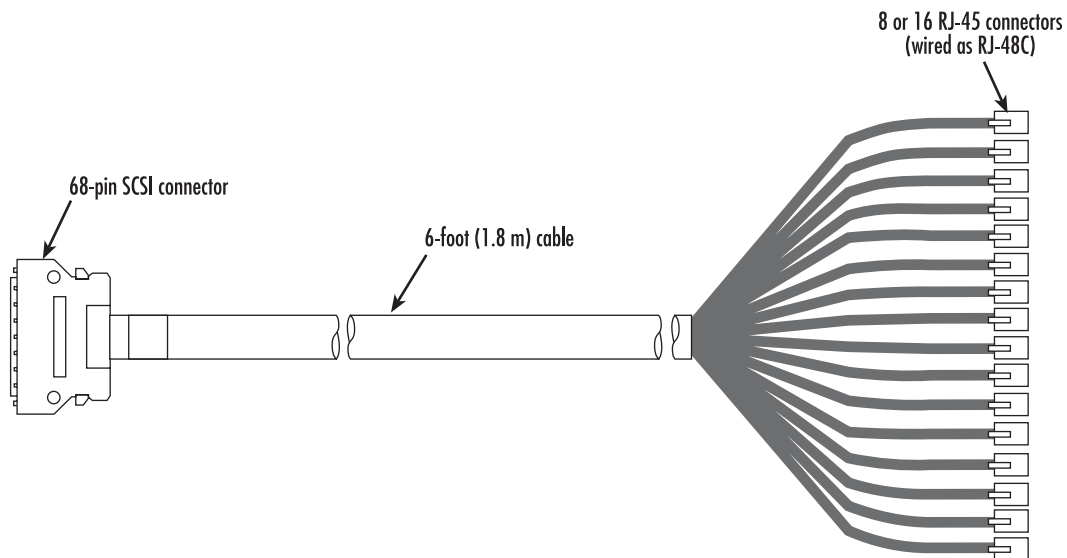

Figure 9. SCSI-to-RJ45 6-foot WAN cable

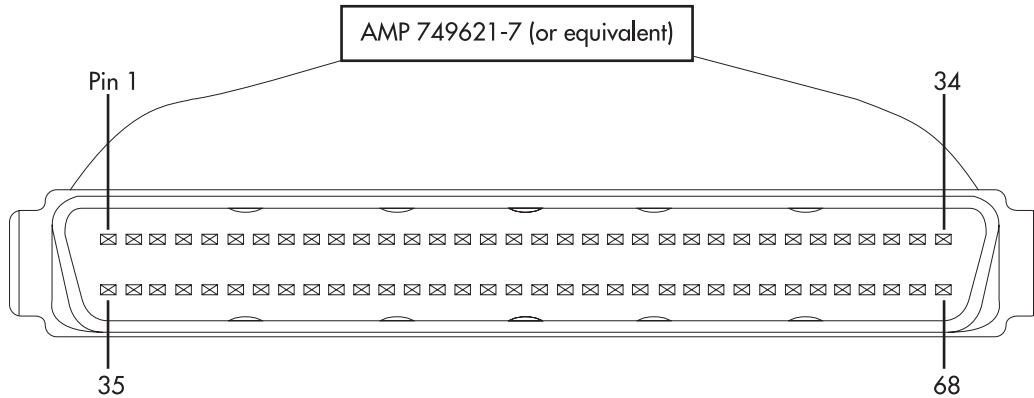

Figure 10. WAN cable's 68-pin SCSI connector

1. Connect the 68-pin SCSI connector (see [figure 10](#)) of the 6-foot WAN cable (see [figure 9](#) on page 24) to the connector on the rear panel of the Model 2616RC.
2. Connect the WAN cable RJ-45 connectors (see [figure 11](#)) to the corresponding ports on a patch panel or local T1/E1 device.

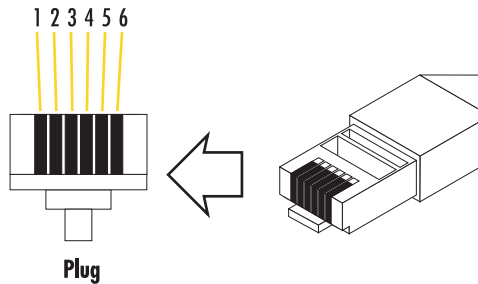

Figure 11. RJ-45 plug

Table 4. RJ-45 plug pin-out

Description	Pin
Transmit pair (TX)	1
Transmit pair (TX)	2
Receive pair (RX)	4
Receive pair (RX)	5

68-pin SCSI to open end cable

The SCSI-to-open-end cable (see [figure 12](#)) connects the 2616RC T1/E1 lines to a punch-down block via 24 gauge solid wire (0.5mm). The other end will be unterminated, open-end twisted pairs. Refer to [table 5](#) for punch-down block wiring information.

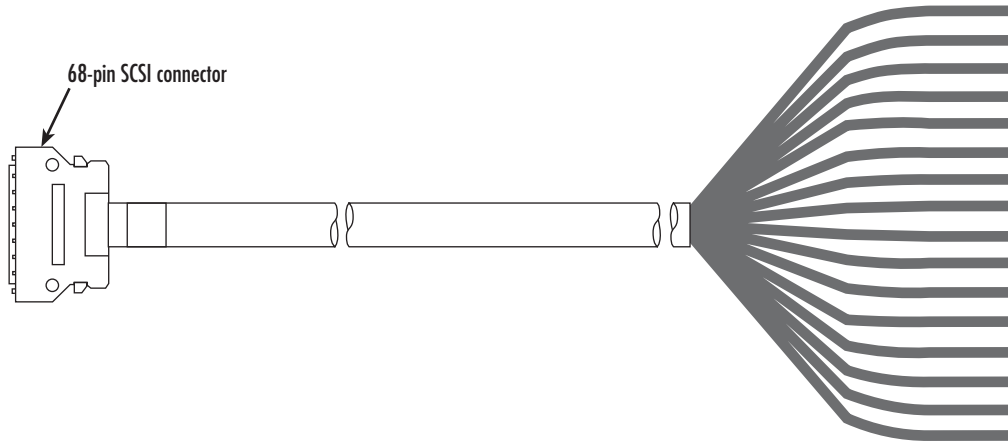

Figure 12. SCSI-to-open-end WAN cable

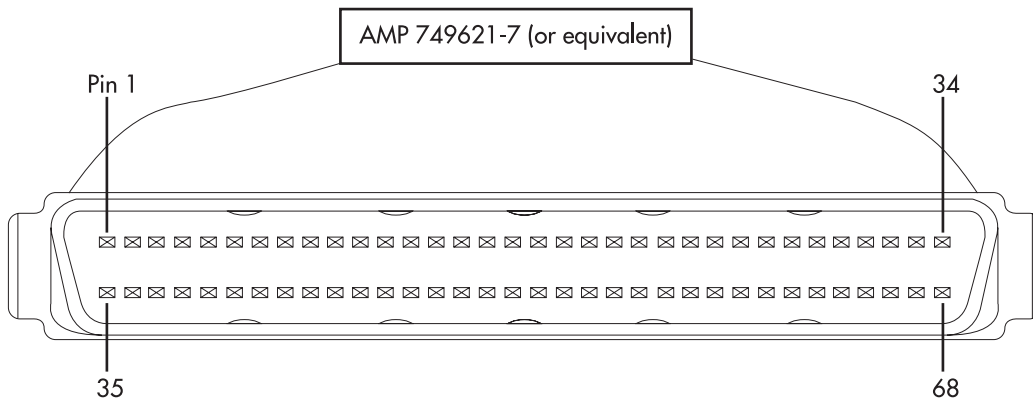

Figure 13. 68-pin SCSI connector

Note The 64 wires in this cable are grouped into blue and orange binders of 32 wires each. Wires in the blue binder have the same color scheme as wires in the orange binder, so it is important to keep each binder separated to avoid confusion when connecting to a punch-down block.

Table 5. WAN cable's 68 non-terminated twisted-pairs

Port/Direction	Pairs	68 Pin Positions	Wire Color Code	Port/Direction	Pairs	68 Pin Positions	Wire Color Code
Port 1/TX	1	1 35	White/Tan Tan/White	Port 9/TX	17	17 51	Tan/Gray Gray/Tan
Port 1/RX	2	2 36	White/Brown Brown/White	Port 9/RX	18	18 52	Brown/Pink Pink/Brown
Port 2/TX	3	3 37	White/Pink Pink/White	Port 10/TX	19	19 53	Brown/Orange Orange/Brown
Port 2/RX	4	4 38	White/Orange Orange/White	Port 10/RX	20	20 54	Brown/Violet Violet/Brown
Port 3/TX	5	5 39	White/Violet Violet/White	Port 11/TX	21	21 55	Brown/Blue Blue/Brown
Port 3/RX	6	6 40	White/Blue Blue/White	Port 11/RX	22	22 56	Brown/Yellow Yellow/Brown
Port 4/TX	7	7 41	White/Yellow Yellow/White	Port 12/TX	23	23 57	Brown/Green Green/Brown
Port 4/RX	8	8 42	White/Green Green/White	Port 12/RX	24	24 58	Brown/Gray Gray/Brown
Port 5/TX	9	9 43	White/Gray Gray/White	Port 13/TX	25	25 59	Pink/Orange Orange/Pink
Port 5/RX	10	10 44	Tan/Brown Brown/Tan	Port 13/RX	26	26 60	Pink/Violet Violet/Pink
Port 6/TX	11	11 45	Tan/Pink Pink/Tan	Port 14/TX	27	27 61	Pink/Blue Blue/Pink
Port 6/RX	12	12 46	Tan/Orange Orange/Tan	Port 14/RX	28	28 62	Pink/Yellow Yellow/Pink
Port 7/TX	13	13 47	Tan/Violet Violet/Tan	Port 15/TX	29	29 63	Pink/Green Green/Pink
Port 7/RX	14	14 48	Tan/Blue Blue/Tan	Port 15/RX	30	30 64	Pink/Gray Gray/Pink
Port 8/TX	15	15 49	Tan/Yellow Yellow/Tan	Port 16/TX	31	31 65	Orange/Violet Violet/Orange
Port 8/RX	16	16 50	Tan/Green Green/Tan	Port 16/RX	32	32 66	Orange/Blue Violet/Blue

Table 5. WAN cable's 68 non-terminated twisted-pairs (Continued)

Port/Direction	Pairs	68 Pin Positions	Wire Color Code	Port/Direction	Pairs	68 Pin Positions	Wire Color Code
	—	33 67	NOT USED		—	34 68	NOT USED

Installing the WAN cable to a punch-down block

Materials required:

- punch-down tool
- Plastic tie wraps
- WAN cable pin-out specification

Procedure:

1. Measure the distance between SCSI cable entry point on the punch-down block frame and the farthest port to be wired on the punch-down block (see figure 14).

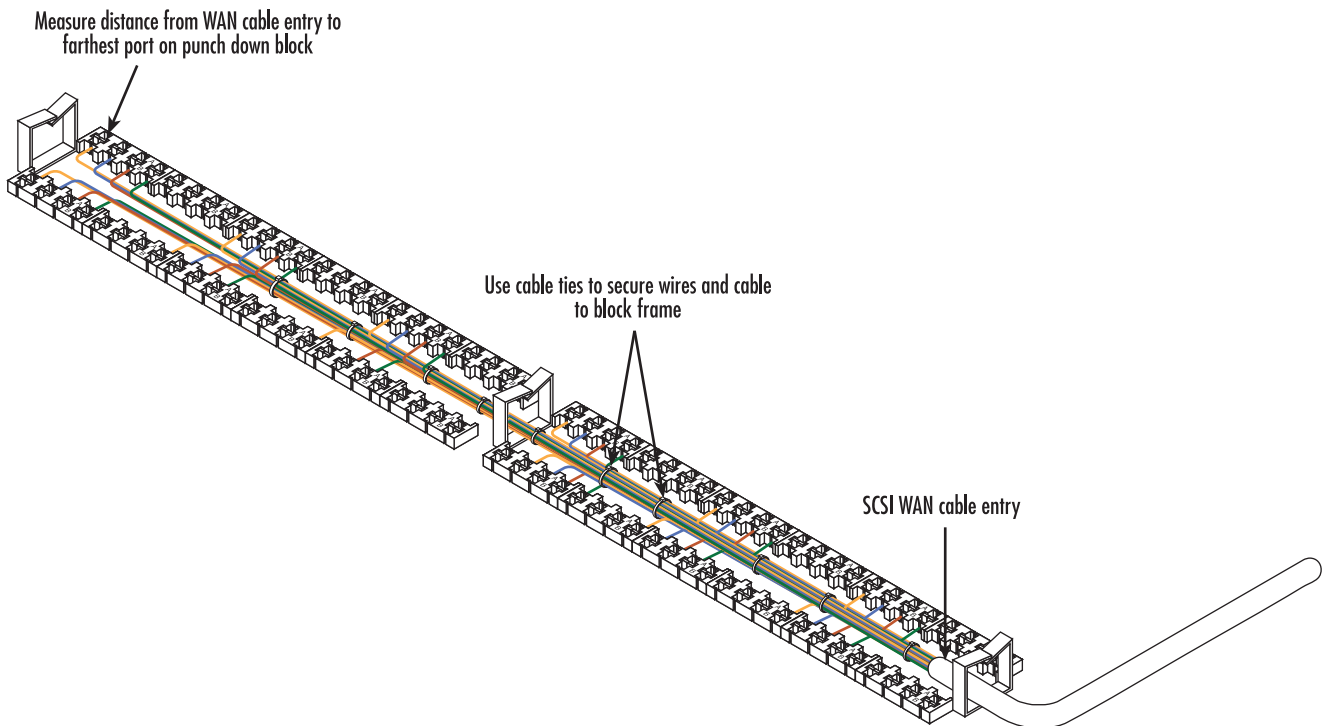

Figure 14. Punch-down block wiring

2. Strip SCSI cable insulation and shielding based on the measurement made in step 1.

3. Review SCSI pin-out (see [table 5](#) on page 27) and punch-block pin-out and cut wires to the required length to reach their respective ports on the punch-down block.
4. Use punch-down tool to press wires down into block terminals.
5. Use cable ties to secure the wires and SCSI cable to the punch-down block (see [table 5](#) on page 27).

Note Cable ties should not allow movement of wires or SCSI cable.

6. Connect the 68-pin SCSI connector of the WAN cable to the connector on the rear panel of the Model 2616RC.

68-pin SCSI to open end, 6 foot cable (part #10-3096TM68-6)–Obsolete

1. This 6-foot WAN cable (see [figure 15](#)) connects the 2616RC T1/E1 lines to a punch-down block via 28 gauge wire (0.3mm). Check your punch-down block wire gauge requirements as most punch-down blocks will not hold 28-gauge wire securely in place.

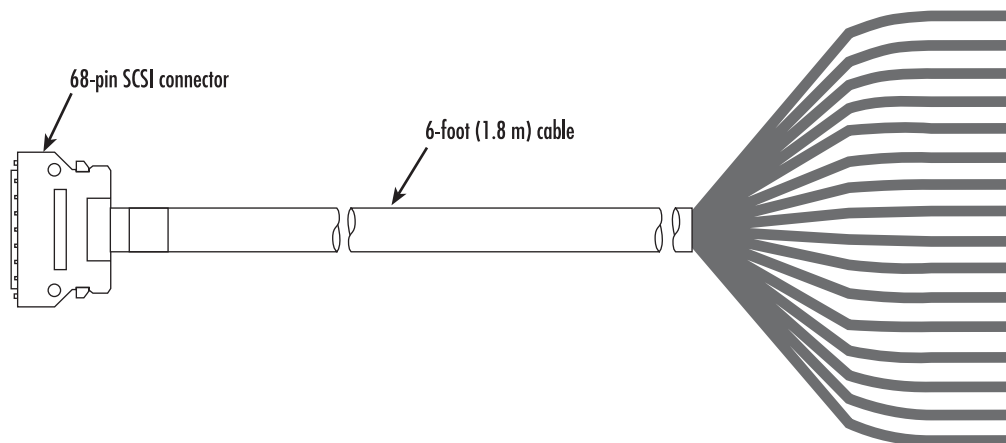

Figure 15. SCSI-to-open-end 6-foot WAN cable (obsolete)

2. See appendix B, “68-pin SCSI-to-open-end 6-foot cable (part #10-3096TM68-6)” on page 78 for pin-out information.

68-pin SCSI to 64-pin female Telco (part #10-3096TM68/64-6)

Do the following to install the 6-foot cable adapter for connection of the 2616RC to a Patton E1 balun rack Models 464RC and 466RC.

1. Connect the 68-pin SCSI connector of the WAN cable to the connector on the rear panel of the Model 2616RC.
2. Connect the WAN cable 64-pin Telco connector to the corresponding port on a the balun rack.

Completing the hardware installation

This section verifies that the T-DAC hardware is operational to the point where you can begin configuring the software settings.

Power is delivered from the Patton ForeFront chassis backplane through the 47-pin PICMG 2.11 power connectors on the 2616RC blades. Upon insertion into the Patton ForeFront chassis, the Model 2616RC immediately powers up and begins its boot cycle. During the boot cycle the following should occur:

1. The POWER LED illuminates, indicating normal power is being applied to the 2616RC.
2. The green SYSTEM LED begins flashing, indicating the 2616RC is operating normally.

Hardware installation is now complete. To configure the 2616RC for operation, refer to chapter 3, “[Configuring the T-DAC for operation](#)” on page 31.

Chapter 3 **Configuring the T-DAC for operation**

Chapter contents

Introduction.....	32
Configuration prerequisites	32
Initial configuration through the RS-232 control port.....	33
Connecting the DB9-RJ45 adapter with the included cable	33
Setting up the HyperTerminal (or similar program) session	34
Using a browser to complete Model 2616RC configuration	37
Displaying the T-DAC 2616RC web administration pages	38
Home page overview	38
Configuring the default gateway	40
Configuring the system clocking parameters	41
Configuring the DS0 mapping	44
Configuring line settings and signaling for E1	46
Accessing the Line Interface Settings	46
Configuring the E1 line interface settings	47
Configuring line settings and signaling for T1	49
Accessing the Line Interface Settings	49
Configuring the T1 line settings	50
Enabling/disabling the alarm card	52
Saving your configuration.....	53
Backing up your configuration parameters.....	53
Backing up the configuration store in flash memory	55
Completing the installation	56

Introduction

This chapter contains the following procedures that describe configuring the Model 2616RC T-DAC for operation:

- “[Configuration prerequisites](#)”—lists the items you need to have on hand before configuring the T-DAC.
- “[Initial configuration through the RS-232 control port](#)” on page 33—describes how to define the 2616RC’s LAN IP address and netmask parameters.
- “[Using a browser to complete Model 2616RC configuration](#)” on page 37—describes how to define the remaining basic configuration parameters in order to bring your T-DAC on-line. The steps are:
 - Defining E1 WAN link parameters (see “[Configuring line settings and signaling for E1](#)” on page 46) or T1 WAN link parameters (see “[Configuring line settings and signaling for T1](#)” on page 49)
 - Defining static connections with DS0 mapping (see page 43)
 - Configuring the system clocking parameters (see page 41)
 - Defining the IP default gateway (see page 52)
 - Enabling the alarm card (see page 40)
- “[Saving your configuration](#)” on page 53—describes how to save your configuration settings.
- “[Backing up your configuration parameters](#)” on page 53—describes how save your configuration parameters to a file
- “[Completing the installation](#)” on page 56—describes how to verify that your 2616RC T-DAC is fully operational.

Configuration prerequisites

You will need the following to configure the 2616RC T-DAC:

- A PC equipped with the following:
 - RS-232/V.24 serial port
 - VT-100 terminal program, e.g., HyperTerminal
 - Ethernet port
 - Web browser (e.g., Netscape Communicator or Microsoft Internet Explorer)
- You will need the following information to configure the Model 2616RC:
 - The IP address and subnet mask for the 2616RC’s Ethernet port
 - The IP address of the default gateway
- If you are using a T1 WAN line, you will need the following information from the telephone company (central office):
 - Line Type: either ESF or D4
 - Line Coding: either B8ZS or AMI
- If you are using a E1 WAN line, you will need the following information from the Telco:

- Line Type: either E1 or E1-CRC
- Line Coding: either HDB3 or AMI

Initial configuration through the RS-232 control port

Initially you must configure the 2616RC's IP address and—in rare instances—change the netmask from the default settings.

Note Do *not* connect power or the Ethernet connection to the Model 2616RC at this time.

Connecting the DB9-RJ45 adapter with the included cable

Do the following:

1. Find the DB9-RJ45 adapter for your PC and RJ-45-to-RJ45 cable shipped with your 2616RC T-DAC.
2. Connect the DB9-RJ45 adapter to your PC's RS-232 serial port.
3. Connect the RJ45-RJ45 cable between the adapter which you installed in step 1 and the *RS-232 Config* port on the front of the Model 2616RC (figure 16).

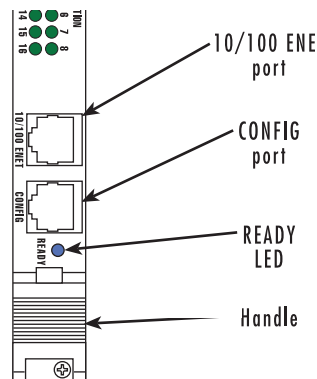

Figure 16. Model 2616RC interface ports

Setting up the HyperTerminal (or similar program) session

Do the following:

1. At your PC, find the file *HYPERTRM.EXE*. Open a HyperTerminal session by double-clicking on the file name.



Figure 17. Connection Description window

2. Type a connection name (e.g., *2616RC Config*), select an icon, then click **OK** (figure 18).



Figure 18. Connect To window

3. On the *Connect To* window (figure 18), set *Connect using:* to one of the options named *Direct to ComX* (where the “X” refers to the number identifying the RS-232 serial port on the PC). In the following procedure, *Com1* will be the used as the port identifier.
4. Click **OK**.
5. The *COM1 Properties* window displays.

- Configure your COM port settings as shown in [figure 19](#), then click **OK**.

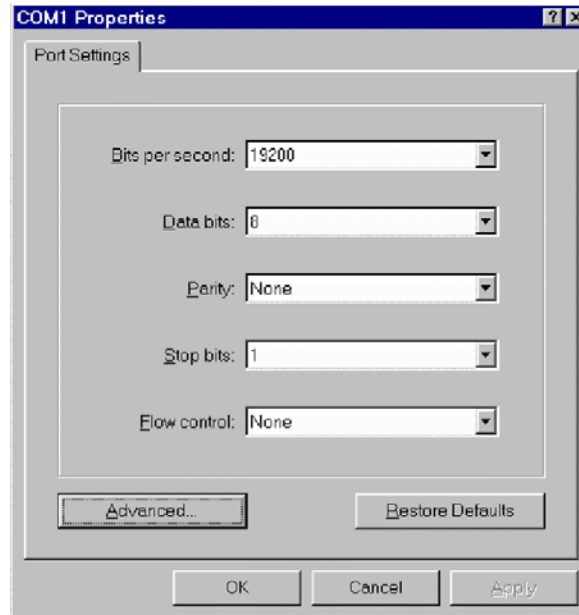

Figure 19. COM1 Properties window

- Click on the **File** menu, then select *Properties*.
- Configure the settings for *Function, arrow and ctrl keys act as to Terminal keys* as shown in [figure 20](#), then click **OK**.

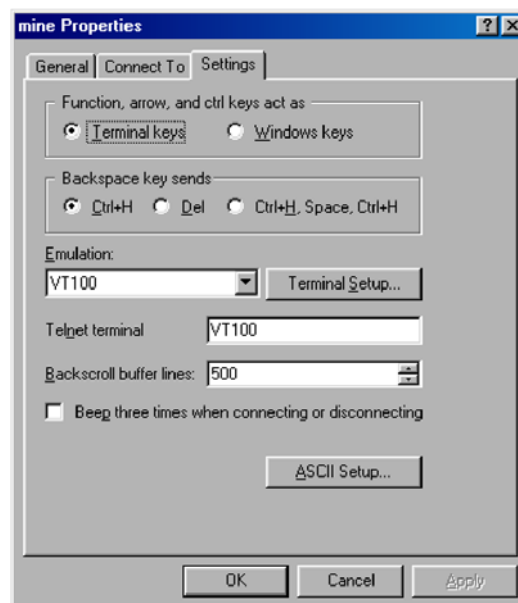

Figure 20. Terminal keys configuration

9. Connect the male end of the 2616RC T-DAC's power cables to the power outlets.
10. Boot up information will display on your HyperTerminal connection window, eventually followed by a login request window (see [figure 21](#)).

```
Patton Electronics Company
Software Revision 3.0.3 May 19 2000 16:48:45
Username: _
```

Figure 21. Login window

11. For the user name, type **superuser**.
12. For the password, type **superuser**; the top level management window then appears (see [figure 22](#)).

```
a HOME
b ALARMS
c DACS
d Clocking
e Ethernet
f Filter IP
g ICMP
h IP
i RIP Version 2
j SNMP
k System
l System Log
m T1/E1 Link
n TCP
o UDP
p Frame Relay
q PPP
r About
>_
```

Figure 22. VT-100 top level management window

13. Type **e** for Ethernet, then press **<Enter>**. The Ethernet configuration window displays (see [figure 22](#)).

```

ETHERNET                               2616RC NAT
-----
ETHERNET
State:                                linkIndication100Duplex(6)
a PrimaryIpAddress:                   192.168.200.223
b PrimaryIpMask:                      255.255.255.0
c PrimaryIpFilters:
d SecondaryIpAddress:                 0.0.0.0
e SecondaryIpMask:                   0.0.0.0
f SecondaryIpFilters:
g Technique:                          static(1)

1 Ethernet Stats...
>

```

Figure 23. Ethernet configuration window

14. Enter **a** for PrimaryIpAddress, then press **<Enter>**.
15. Type your LAN IP address followed by pressing **<Enter>**.
16. Press the left-arrow cursor key on your keyboard to return to the previous screen.
17. If you do not need to change the PrimaryIpMask from the default of 255.255.255.0, go to step 20. Otherwise, type **b** and type the new LAN Mask in the same manner as when entering a LAN IP address.
18. Press the left-arrow cursor key until the top level management window displays (see [figure 22](#) on page 36).
19. Type **a** for *HOME*, then press **<Enter>**.
20. Under the *Current Status* page, type **1** (*store Config(1)*) to save the changes you have just made to the configuration.

This completes the initial configuration of the Model 2616RC. The next steps in configuration will be done using your Web browser connected via Ethernet to the 2616RC.

Using a browser to complete Model 2616RC configuration

This section describes the following procedures:

- Displaying the T-DAC home page (see “[Displaying the T-DAC 2616RC web administration pages](#)” on page 38)
- Configuring the T1/E1 WAN links (see “[Configuring line settings and signaling for E1](#)” on page 46 or “[Configuring line settings and signaling for T1](#)” on page 49)
- Setting static connections with DS0 mapping (see “” on page 43)

- Setting the system clocking parameters (see “Configuring the system clocking parameters” on page 41)
- Configuring the IP default gateway (see “Configuring the default gateway” on page 40)

Displaying the T-DAC 2616RC web administration pages

Do the following:

1. Connect your PC's Ethernet connection to the Ethernet LAN.
2. Connect the 2616RC's T-DAC 10/100 Ethernet connection to the Ethernet LAN.
3. At your PC, open a Web browser session. In your browser's URL/address field type the IP address of the Model 2616RC (for example, if the Model 2616RC's IP address is *123.124.221.10*, you would type **123.124.221.10** in the browser's URL/address field). If you do not have an IP address in your TDAC, refer to “Initial configuration through the RS-232 control port” on page 33.
4. A login prompt will appear. In the username field type **superuser** then press **<Tab>** to move the cursor to the Password field. In the password field type **superuser** then press **<Enter>**.
5. The 2616RC Configuration Menu home page will appear (see figure 24).

The screenshot displays the Patton Home Page for a Model 2616RC T-DAC. The page is titled "Patton Home Page" and shows the following information:

- Model 2616RC TDM Digital Access Concentrator Software Revision 1.3.10 Mar 24 2009 10:12:06**
- Status of T-DAC** table:

Number of T1/E1 Ports:	4
% CPU Idle:	99
Running Since Last Boot:	18:41:14 hours
Chassis Address:	31
Slot Address:	4
Node ID:	0
Network Area:	0
Chassis Type:	2U-Chassis(2)
Current Card State:	Clear
Total Card Alarms:	0

Below the table, there are **Operator Actions** buttons:

- Record Current Configuration
- Hard Reset
- Set Factory Default Configuration

The left sidebar contains a **2616RC CONFIGURATION MENU** with the following links:

- HOME
- Import/Export
- Alarms
- DSO Mapping
- System Clocking
- Ethernet
- Frame Relay
- In-Band Mgmt
- IP
- IP Filtering
- PPP
- RIP Version 2
- SNMP
- System
- Alarm Card
- System Log
- T1/E1 Link
- About
- License

Figure 24. 2616RC Configuration Menu home page

Home page overview

The HOME window is divided into two panes: the Configuration Menu pane and the Configuration/information pane (see figure 25 on page 39). The Configuration Menu contains the links to the various Model 2616RC subsystems, while in the Configuration/information pane, you can view status and other information or make changes to the system configuration. Unlike the Configuration Menu pane, which appears the same no matter which subsystem page you may select, the Configuration/information pane contents will change as you move from one subsystem page to another.

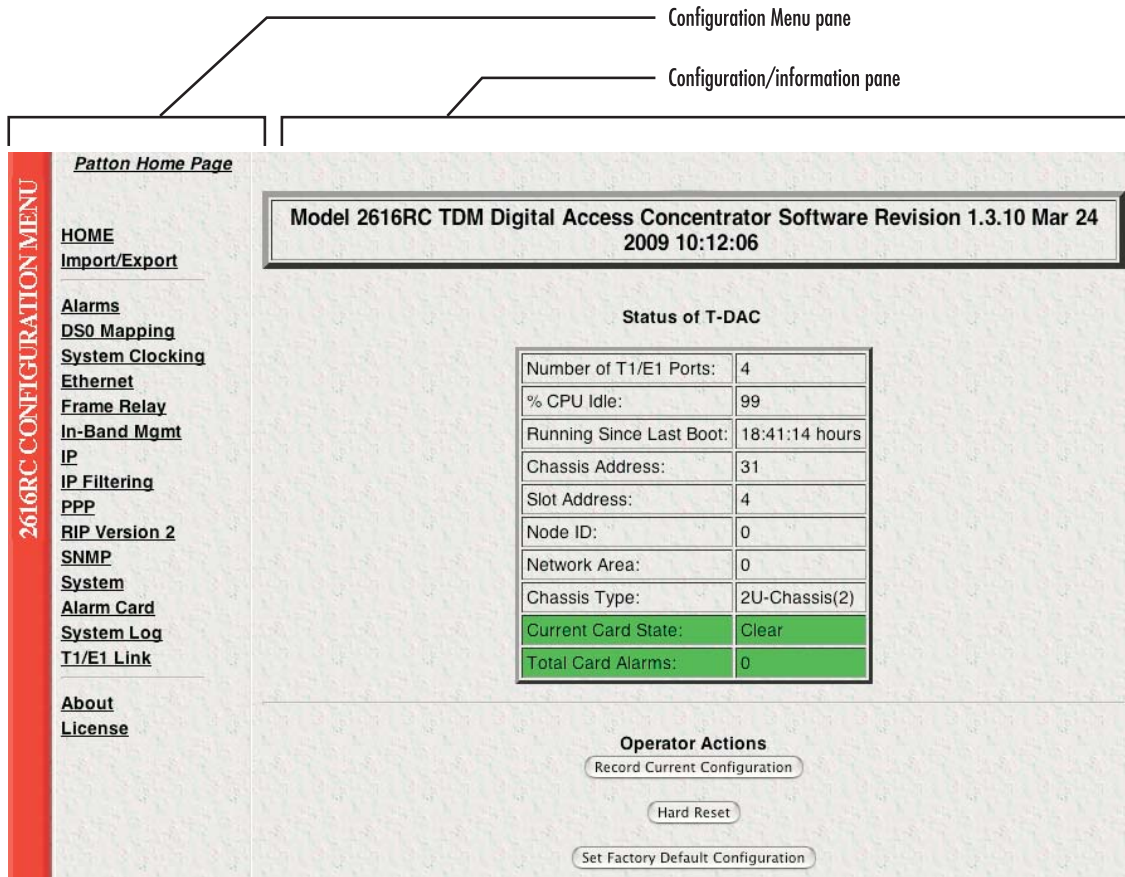

Figure 25. HOME page window panes



Figure 26. Operator Actions buttons

From the Home page, the following actions can be performed:

- **Record Current Configuration**—clicking on this button (see figure 26) saves the current configuration from volatile DRAM memory to FLASH memory. Once the configuration is saved into FLASH memory, the configuration will not be lost even if the power is cycled on the 2616RC. Initially, changes made to the 2616RC configuration are stored in volatile DRAM, enabling the user to set the box up with a working configuration before committing it to storage in FLASH. When you select **Record Current Configuration**, the 2616RC stores your changes to FLASH memory.

Note If you want to save the configuration changes that you have made, you must click on **Record Current Configuration**, otherwise all configuration changes will be lost if the power to the Model 2616RC is turned off.

- **Hard Reset**—this button (see [figure 26](#)) causes the Model 2616RC to perform a cold restart. When you select **Hard Reset**, the T-DAC confirms that you want to execute this command. Then, the T-DAC will disconnect all current sessions, re-initialize the interfaces, and re-load configuration parameters from FLASH.
- **Set Factory Default Configuration**—this button (see [figure 26](#)) clears out the configuration in FLASH and loads the factory default parameters into FLASH memory. The factory default settings will not execute on the Model 2616RC until it is re-booted by doing a Hard Reset.

Note **Set Factory Default Configuration** ([figure 26](#)) will delete any routing information, the Model 2616RC's Ethernet IP address, and any other site-specific settings made for your particular installation. You will have to re-enter the Model 2616RC's Ethernet IP address and net-mask using the rear panel control port before using the HTTP/HTML Management pages.

Configuring the default gateway

The default gateway IP address, if defined, is used solely for managing the 2616RC remotely via the Ethernet port. The 2616RC does not transmit or receive user data nor any other traffic via the default gateway IP address or the Ethernet port.

Do the following to add the default gateway:

1. On the *2616RC Configuration Menu*, click the *IP* hyperlink to open the **IP Configuration** page.
2. Click the *Routing Info* hyperlink to open the **IP Routing Information** page ([figure 27](#)).

The screenshot shows the 'IP ROUTING INFORMATION' page. At the top right is a 'T-DAC' button. Below it is a table with the following data:

Destination	Mask	Gateway	Cost	Interface	Protocol	State
10.10.0.0	255.255.0.0	0.0.0.0	1	1	local(1)	active(2)

Below the table is an 'Add a route:' section with three rows of input fields and 'Add Route' buttons:

- Row 1: Destination: 0.0.0.0, Mask: (empty), Gateway: 0.0.0.0, Add Route
- Row 2: Destination: 0.0.0.0, Mask: 0.0.0.0, Gateway: 0.0.0.0, Add Route
- Row 3: Advanced...: Destination: 0.0.0.0, Mask: 0.0.0.0, Interface: 0, Add Route

At the bottom left, there is a link for 'O/S forwarding table'.

Figure 27. IP Routing Information Page

3. The existing route you see in the table is the LAN IP address you assigned to the 2616RC during initial configuration through the RS-232 control port, earlier in this chapter.
4. To enter the default gateway, use the first **Add a route line**. The *Destination* shall remain *0.0.0.0*, and there is no mask to enter.

5. In the *Gateway* box, type your default gateway IP address for the 2616RC.
6. Click the **Add Route** button to save your configuration.

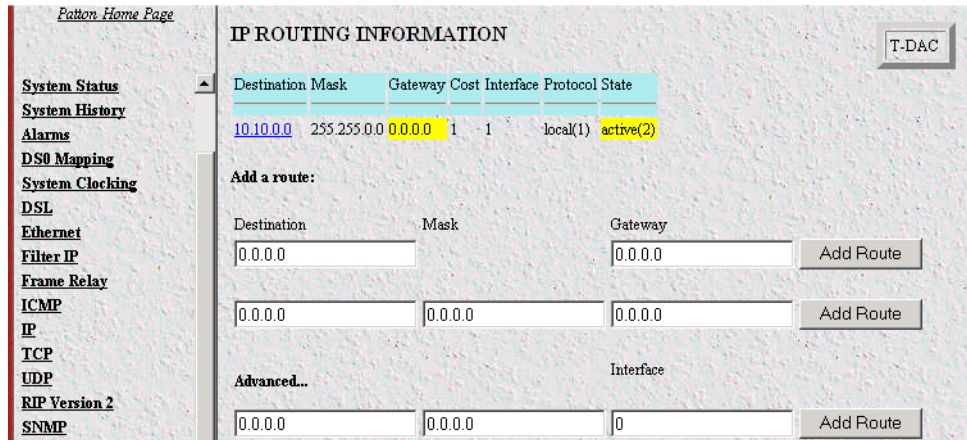

Figure 28. IP Routing Information window

7. The route which you already see in the table appeared upon the configuration of the LAN IP address.
8. To enter the default gateway, use the first *Add Route* line. The *Destination* shall remain as *0.0.0.0*. There is no mask to enter.
9. Enter the IP address in the *Gateway* box. This is the default gateway.
10. Click on the **Add Route** button.

Configuring the system clocking parameters

In this section you will define clocking sources for the *main reference* and *fallback reference* on the 2616RC T-DAC. Clocking source selection will depend on the clocking role you assign to the blade: *master(1)*, *secondary(2)*, or *slave(3)*. The master will drive the main reference clock for the chassis. Should the master fail, the secondary will drive the main reference. Slaves will not drive any clock reference. Most often the 2616RC will be configured as *slave(3)*, with another blade (such as the Patton Model 6511) configured as the *master(1)*.

You can choose any one of the WAN ports, an internal oscillator, or system clock (provided by the ForeFront chassis). Unless it fails or becomes disconnected, the main reference provides the system clock for the 2616RC. Should this failure occur, the fallback reference will be the clocking source for the 2616RC's system clock.

Example 1

Your 2616RC is the only blade in the chassis and must be configured as the *system clocking master*. This example assumes you will use T1/E1 port #1 as the main reference and T1/E1 port #2 as the fallback reference. To define the clocking source, do the following:

1. Connect a T1/E1 WAN line to WAN port #1 through the 2616RC's WAN port cable.
2. Connect a T1/E1 WAN line to WAN port #2 through the 2616RC's WAN port cable.

- Click the *System Clocking* hyperlink on the *2616RC Configuration Menu* to open the *System Clocking Configuration* page (see [figure 29](#)).

Figure 29. System Clocking Configuration page, example 1

- For *Clock Reference* select *master(1)*.
- For *Main Reference* select *wan-1(1)*.
- For *Fallback Reference* select *wan-2(2)*.
- Click on the **Submit Query** button.
- Select *enable(1)* to enable the fallback reference clock.
- Click the **Submit Query** button.

Example 2

Another card such as the Patton Model 6511 is the clocking master and your 2616RC is a secondary or slave. This example assumes you will use the system clock as the main reference and WAN port #1 as the fallback reference. To define the clocking source, do the following:

Note If there are two or more ForeFront TDM cards (6511RC, 3096RC, 2616RC, 3196RC) installed in the chassis (or chassis segment in the 6U chassis), only **one** card can be set as the master clock. Another may be set as a secondary clock, although it is not necessary. All remaining cards must be set as slaves.

- Connect a T1/E1 WAN line to WAN port #1 through the 2616RC's WAN port cable.

- Click the *System Clocking* hyperlink on the *2616RC Configuration Menu* to open the *System Clocking Configuration* page (see [figure 30](#)).

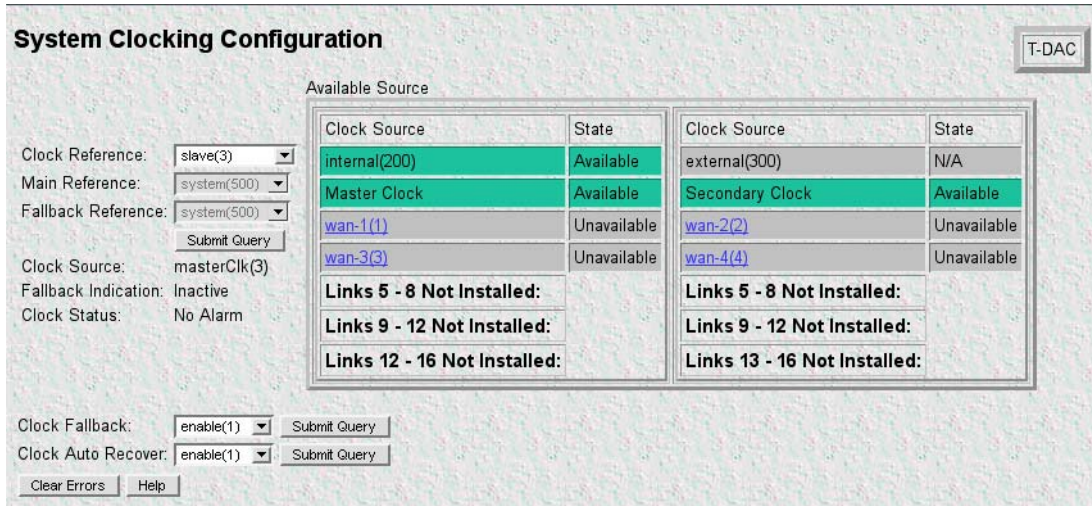

Figure 30. System Clocking Configuration page, example 2

- For *Clock Reference* select *secondary(2)* or *slave(3)*.

Note If slave is selected you will not be able to configure the main or fallback reference. If you selected slave(3), go to step 6. Otherwise, continue on to step 4.

- If you selected *secondary(2)* in step 3, for *Main Reference* select *system(500)*.
- For *Fallback Reference* select *wan-1(1)*.
- Click the **Submit Query** button shown in [figure 31](#).

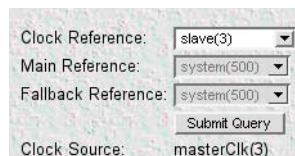

Figure 31. Clock Reference Submit Query button

- Select *enable(1)* to enable the fallback reference clock.
- Click the **Clock Fallback Submit Query** button shown in [figure 32](#).



Figure 32. Clock Reference Submit Query button

Configuring the DS0 mapping

You need to make internal connections between a T1/E1 link and its destination. The destination of the T1/E1 link may be another T1/E1 port within the T-DAC, or the TDM bus in the chassis connecting to another T-DAC, DSL, or STM-1 card.

When configuring the 2616RC for T1/E1 cross connection the following scenarios may be encountered:

- Mapping DS0s from one E1/T1 port to another T1/E1 port on the same card. This is the simplest cross connection possible; DS0s are mapped from one T1/E1 port to another.
- Mapping DS0s from one E1/T1 port to another T1/E1 port on another card (or a DSL port on a Patton Model 3096RC) within the chassis. In this scenario, DS0s are first mapped from the originating 2616RC card T1/E1 port to a H.110 port (chassis TDM system bus). The destination card, similarly, must have a DS0 map from the H.110 bus to the appropriate T1/E1 port.
- Mapping DS0s from a T1/E1 port to an STM-1 card in the same chassis. In this scenario, the 2616RC first maps DS0s from a T1/E1 port to an H.110 port (TDM system bus). The system TDM bus, connected to all cards in the system, connects with a Patton 6511RC STM-1 card; DS0s are then placed into STM1 containers.

To define DS0 mapping for two T1/E1 ports, do the following:

1. On the Configuration Menu click DS0 Mapping hyperlink. The DS0 Mapping Overview window (see figure 33) displays.

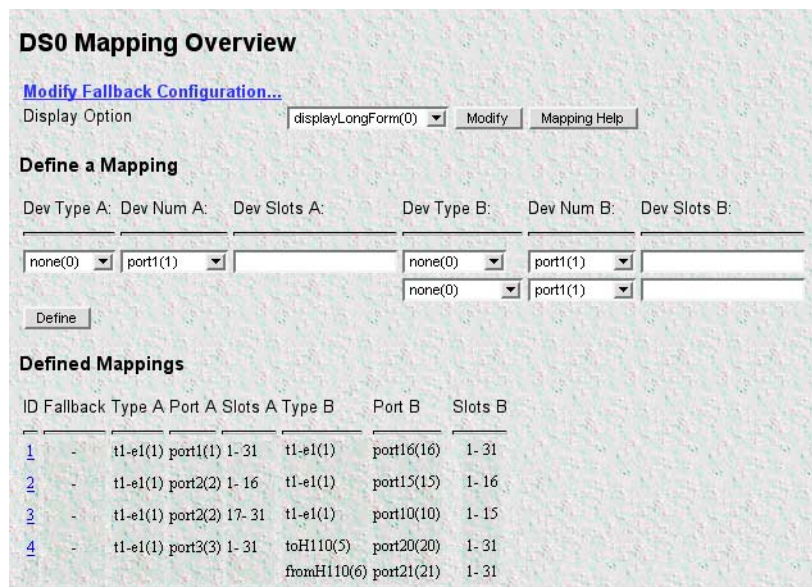

Figure 33. DS0 Mapping Overview window

2. In the Display Option drop-down menu (see figure 34), select displayLongForm(0).



Figure 34. Display Option menu

To define each DS0 Mapping you will create a static connection. “A” and “B” designate the two ends of the static connection. For each static connection you will define the following parameters:

- **Device Type.** Specifies the physical interface type for the connection. You may select either `t1-e1 (1)` or `none(0)`. Additionally, for Device Type B, there is an option for `toH.110(5)` and `fromH.110(6)`, indicating direction of the T1/E1 DS0s mapped to the H.110 (TDM bus system).
- **Device Number.** Defines which T1/E1 port number on the 2616RC you are mapping. For example, to map a connection for T1/E1 port 3 you would select `port3(3)`.
- **Device Slots.** Defines which DS0 channels will be mapped. Each DS0 channel is 64 kbps. Each T1 port has 24 DS0 channels. Each E1 WAN port has 32 DS0 channels. When defining time slots you must select the same number of Device Slots on the “A” and “B” sides of the connection. The slots are defined by entering a text string that represents the slots. For the T1/E1 ports, the slots that are available are 1–32. For a WAN port configured as a T1, the available slots are numbered from 1–24. For a WAN port configured as an E1, the available slots are 1–32. The H.110 (TDM system bus) is comprised of 32 ports; each port contains 128 unidirectional slots.

Examples for configuring static connections:

- Example 1: Connecting DS0s from an E1 port to another E1 port within one card.
- Example 2: Connecting DS0s from an E1 port on one card to an E1 port on another card via H.110 bus.

Example 1

Connect T1/E1 ports 1 and 10 to live E1 lines.

Solution:

1. Under Dev Type A, select `t1-e1(1)`.
2. Under Dev Num A, select `port1(1)`.
3. Under Dev Slots A, enter 1 - 32.
4. Under Dev Type B, select `t1-e1(1)`.
5. Under Dev Num B, select `port10(10)`.
6. Under Dev Slots B, enter 1 - 32.
7. Click the **Submit Query** button.

Example 2

Connect T1/E1 port 1 of card 1, and T1/E1 port 10 of card 2 to live E1 lines.

Solution:

Card one mapping

1. Under Dev Type A, select `t1-e1(1)`.
2. Under Dev Num A, select `port1(1)`.
3. Under Dev Slots A, enter 1 - 32.
4. Under Dev Type B, select `toH110`.

5. Under Dev Num B, select port1(1).
6. Under Dev Slots B, enter 1 - 32.
7. Under Dev Type B, select fromH110.
8. Under Dev Num B, select port1(1).
9. Under Dev Slots B, enter 32 - 62.
10. Click the **Submit Query** button.

Card 2 mapping

1. Under Dev Type A, select t1-e1(1).
2. Under Dev Num A, select port10(10).
3. Under Dev Slots A, enter 1 - 32.
4. Under Dev Type B, select fromH110.
5. Under Dev Num B, select port1(1).
6. Under Dev Slots B, enter 1 - 32.
7. Under Dev Type B, select toH110.
8. Under Dev Num B, select port1(1).
9. Under Dev Slots B, enter 32 - 62.
10. Click the **Submit Query** button.

Configuring line settings and signaling for E1

Accessing the Line Interface Settings

1. On the *2616RC Configuration Menu*, click the *T1/E1 Link* hyperlink to open the T1/E1 LINK ACTIVITY OVERVIEW page (see [figure 35](#)).

Blade 1

T1/E1 LINK ACTIVITY OVERVIEW

View Links 1 - 4: [View Links...](#)

View Link 1	Circuit ID:WAN Circuit	Line Type: dsx1E1(4)	Line Status:No Alarm
View Link 2	Circuit ID:WAN Circuit	Line Type: other(1)	Line Status:No Alarm
View Link 3	Circuit ID:WAN Circuit	Line Type: other(1)	Line Status:No Alarm
View Link 4	Circuit ID:WAN Circuit	Line Type: other(1)	Line Status:No Alarm

Links 5 - 8 Not Installed:

Links 9 - 12 Not Installed:

Links 13 - 16 Not Installed:

View All Links: [View Links...](#)

Figure 35. T1/E1 Link Activity Overview page

2. *View Link 1* corresponds to the first WAN circuit on the T-DAC. To the right of *View Links 1-4* click the *View Links...* hyperlink to open the T1/E1 LINK ACTIVITY PORTS 1 – 4 page (see figure 36).

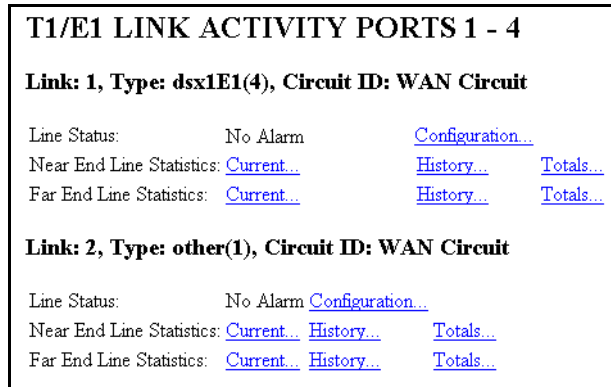

Figure 36. T1/E1 Link Activity Ports 1 – 4 page.

3. Click the *Configuration...* hyperlink then click the *Modify Configuration...* hyperlink to open the WAN Circuit CONFIGURATION LINK window (see figure 37) and view the *Line Interface Settings*.

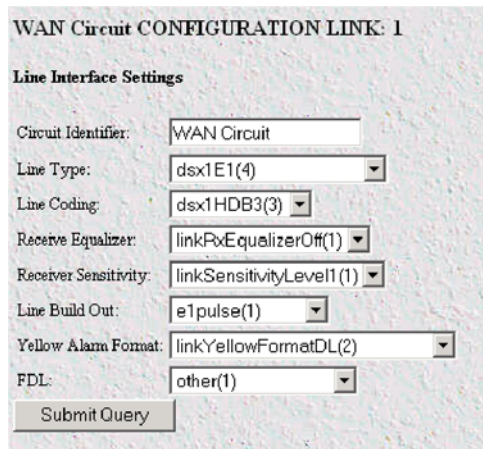

Figure 37. WAN Circuit Configuration page, Line Interface Settings

Configuring the E1 line interface settings

1. From the *Line Type* pull-down menu (figure 38) select *dsx1E1(4)* or *dsx1E1-CRC(5)*.

Line Interface Settings

Circuit Identifier: WAN Circuit

Line Type: dsx1E1-CRC(5)

Line Coding: other(1)
dsx1ESF(2)
dsx1D4(3)
dsx1E1(4)

Receive Equalizer: dsx1E1-CRC(5)

Line Build Out: dsx1E1-MF(6)
dsx1E1-CRC-MF(7)
dsx1E1-Transparent(8)

Yellow Alarm Format:

FDL:

Submit Query

Figure 38. Line Type pull-down menu

- From the *Line Coding* pull-down menu (figure 39) select *dsx1AMI(5)* or *dsxHDB3(3)*. Most installations will use HDB3.

Line Interface Settings

Circuit Identifier: WAN Circuit

Line Type: dsx1E1-CRC(5)

Line Coding: dsx1HDB3(3)

Receive Equalizer: dsx1JBZS(1) # (1)

Line Build Out: dsx1HDB3(3)

Yellow Alarm Format: dsx1ZBTSl(4) DL(2)

FDL: dsx1AMI(5) other(6)

Submit Query

Figure 39. Line Coding pull-down menu with dsx1HDB3(3) selected

- From the *Line Build Out* pull-down menu (figure 40) select *e1pulse(1)*.

Line Interface Settings

Circuit Identifier: WAN Circuit

Line Type: dsx1E1-CRC(5)

Line Coding: dsx1HDB3(3)

Receive Equalizer: linkPxEqualizerOff(1)

Line Build Out: e1pulse(1)

Yellow Alarm Format: triState(0) (2)

FDL: e1pulse(1)
t1pulse0dB(2)
t1pulse-7dB(3)
t1pulse-15dB(4)

Submit Query

Figure 40. Line Build Out pull-down menu with e1pulse(1) selected

- Click the **Submit Query** button to apply your line interface settings.

At this point the T1/E1 front panel LEDs will become active. The T1/E1 indicator LEDs should now display a steady green light, indicating the T-DAC has synchronized with the E1 line. If the E1 line is not connected to the 2616RC, T1/E1 link pages will display the hyperlink *ALARMS PRESENT* (figure 41) for that T1/E1 link.

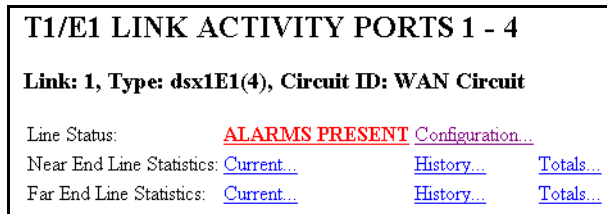

Figure 41. E1 ALARMS PRESENT indicator

After you connect the E1 line to the WAN port on the rear of the Model 2616RC these alarms should disappear.

Configuring line settings and signaling for T1

Accessing the Line Interface Settings

1. On the 2616RC Configuration Menu, click the T1/E1 Link hyperlink to open the T1/E1 LINK ACTIVITY OVERVIEW page (figure 42).

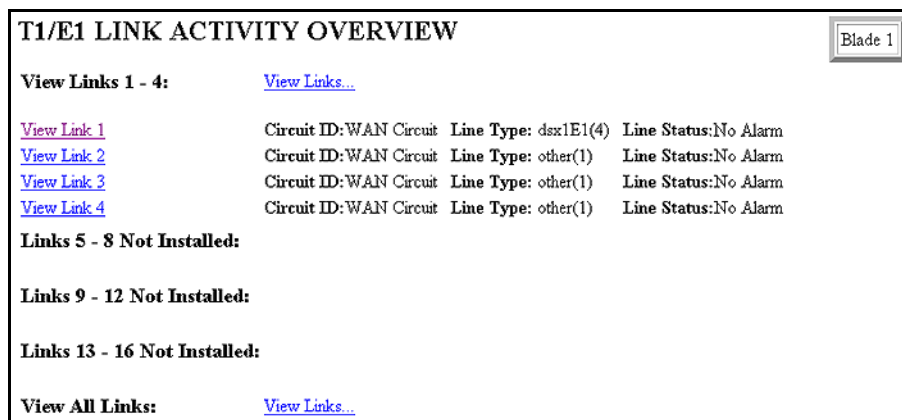

Figure 42. T1/E1 Link Activity Overview page

2. *View Link 1* corresponds to the first WAN circuit on the T-DAC. To the right of *View Links 1-4* click the *View Links...* hyperlink to open the T1/E1 LINK ACTIVITY PORTS 1 – 4 page (figure 43).

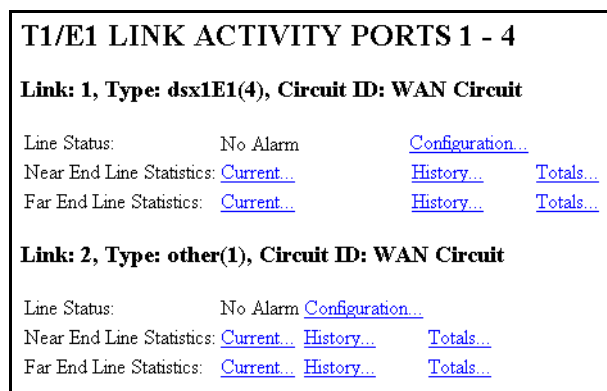

Figure 43. T1/E1 Link Activity Ports 1 – 4 page.

- Click the *Configuration...* hyperlink, then click the *Modify Configuration...* hyperlink to open the WAN Circuit CONFIGURATION LINK window (figure 44) and view the *Line Interface Settings*.

WAN Circuit CONFIGURATION LINK: 1

Line Interface Settings

Circuit Identifier: WAN Circuit

Line Type: dsx1E1(4)

Line Coding: dsx1HDB3(3)

Receive Equalizer: linkRxEqualizerOff(1)

Line Build Out: e1pulse(1)

Yellow Alarm Format: linkYellowFormatDL(2)

FDL: other(1)

Submit Query

Figure 44. WAN Circuit Configuration page, Line Interface Settings

Configuring the T1 line settings

- From the *Line Type* pull-down menu (figure 45) select either:

- *dsx1ESF(2)* - indicates Extended SuperFrame DS1
- *dsx1D4* - indicates AT&T D4 format DS1

Line Interface Settings

Circuit Identifier: WAN Circuit

Line Type: dsx1ESF(2)

Line Coding: other(1)

Receive Equalizer: dsx1D4(3)

Line Build Out: dsx1E1(4)

Yellow Alarm Format: dsx1E1-CRC(5)

FDL: dsx1E1-MF(6)

Submit Query

Figure 45. Line Type pull-down menu with dsx1ESF(2) selected

- From the *Line Coding* pull-down menu (figure 46), select *dsx1B8ZS(2)* or *dsx1AMI(5)*.

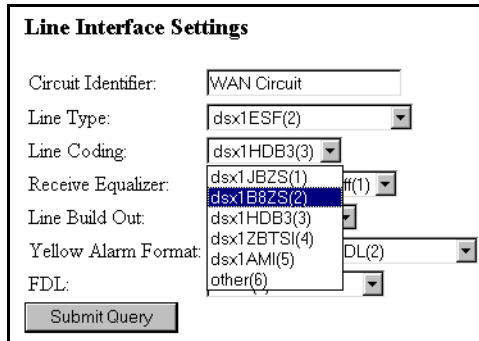

Figure 46. Line Coding pull-down menu with dsx1B8ZS(2) selected

- From the *Line Build Out* pull-down menu (figure 47) select *t1pulse0dB(1)*.

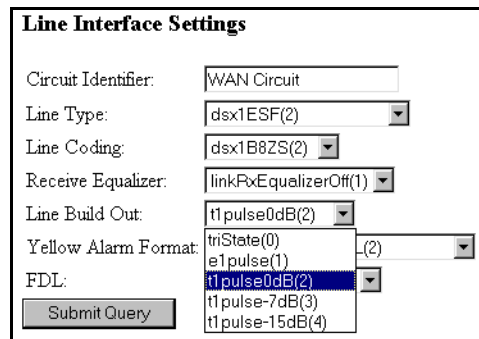

Figure 47. Line Build Out pull-down menu with t1pulse0dB(1) selected

- Click on **Submit Query** to apply your settings.

At this point the T1/E1 front panel LEDs will become active. The T1/E1 indicator LED should now display a steady green light, indicating the T-DAC has synchronized with the E1 line. If the E1 line is not connected to the 2616RC, T1/E1 link pages will display the hyperlink *ALARMS PRESENT* (figure 48) for that T1/E1 link.

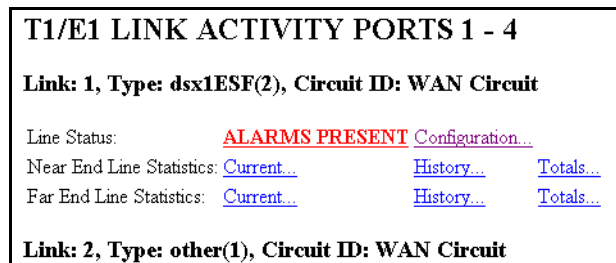

Figure 48. T1 ALARMS PRESENT indicator on T1/E1 LINK ACTIVITY page

After you connect the E1 line to the WAN port on the rear of the Model 2616RC, these alarms should disappear.

Enabling/disabling the alarm card

The *Alarm Card* window (see [figure 49](#)) is where you can configure the alarm card polling mode to determine whether the 2616RC monitors the alarm card status for the chassis.

1. Click on *Alarm Card* under the configuration menu to display the *Alarm Card Information* window.
2. From the *Alarm Card Polling Mode* menu, select an option from the drop-down menu to enable/disable the alarm card.
 - doNotMonitor(0)—Disables the alarm card
 - monitorAlarmCard(1)—Enables the alarm card
3. Click **Submit** to save the change.

Note If the chassis contains more than one (2616RC/3096RC/3196RC) or any combination thereof, then only **one** card should be enabled to monitor the alarm card.

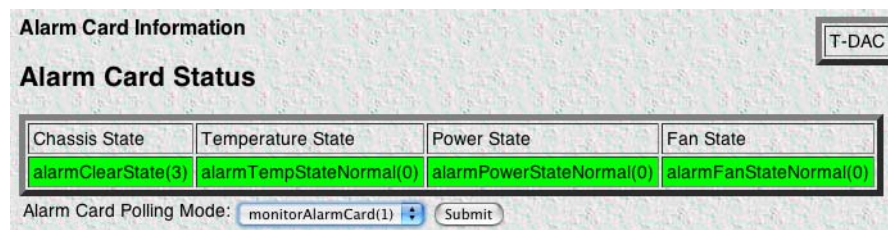

Figure 49. Alarm Card Information window

Saving your configuration

At this point you have completed the basic configuration of your T-DAC for operation. To save your configuration settings in non-volatile RAM, do the following:

1. On the Configuration Menu click the Select *HOME* hyperlink to open the *2616RC Configuration Menu* home page (figure 50).

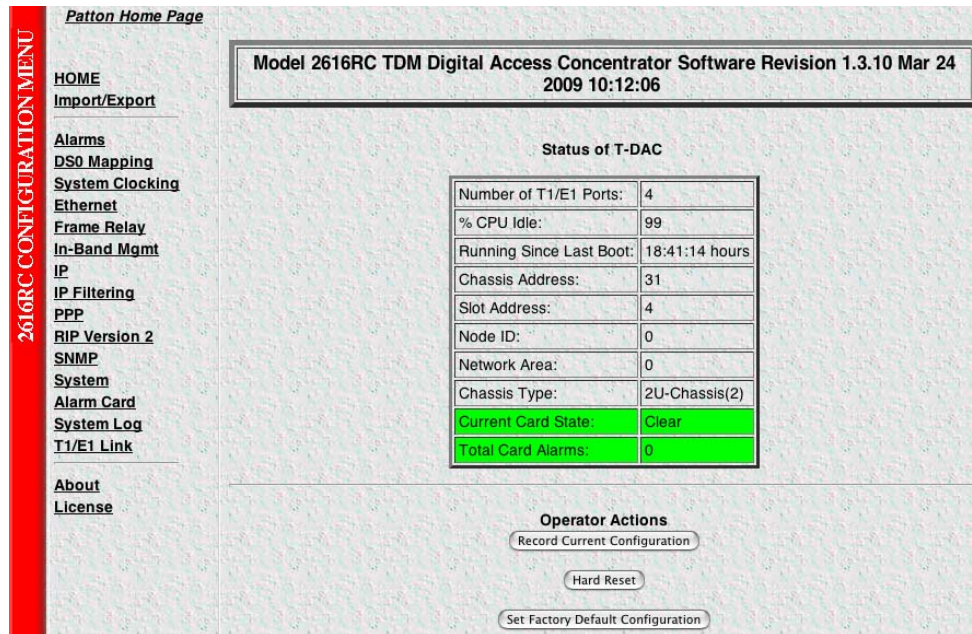

Figure 50. 2616RC Configuration Menu home page

2. Click the **Record Current Configuration** button (see figure 50).

Note All configuration settings will be lost unless you click on the **Record Current Configuration** button before you power down or reset the T-DAC.

Backing up your configuration parameters

The 2616RC T-DAC provides Import/Export functions. These functions enable you to back up (*export*) and restore (*import*) your T-DAC's configuration parameters against possible failure. Should your T-DAC ever need replacing, a previously saved copy of your (*exported*) configuration file can quickly be loaded (*imported*) into a replacement T-DAC.

Note Import/Export functions require superuser access privileges.

Note The parameters that will be exported are the power-up settings as they are stored in flash memory and *may not* be the current operating parameters. To ensure that you export the most current parameters, go to HOME, then under *Operator Actions*, click on the **Record Current Configuration** button.

To import or export a configuration, do the following:

1. On the Configuration Menu pane, click the *Import/Export* hyperlink to display the **IMPORT/EXPORT** page (see [figure 51](#)).

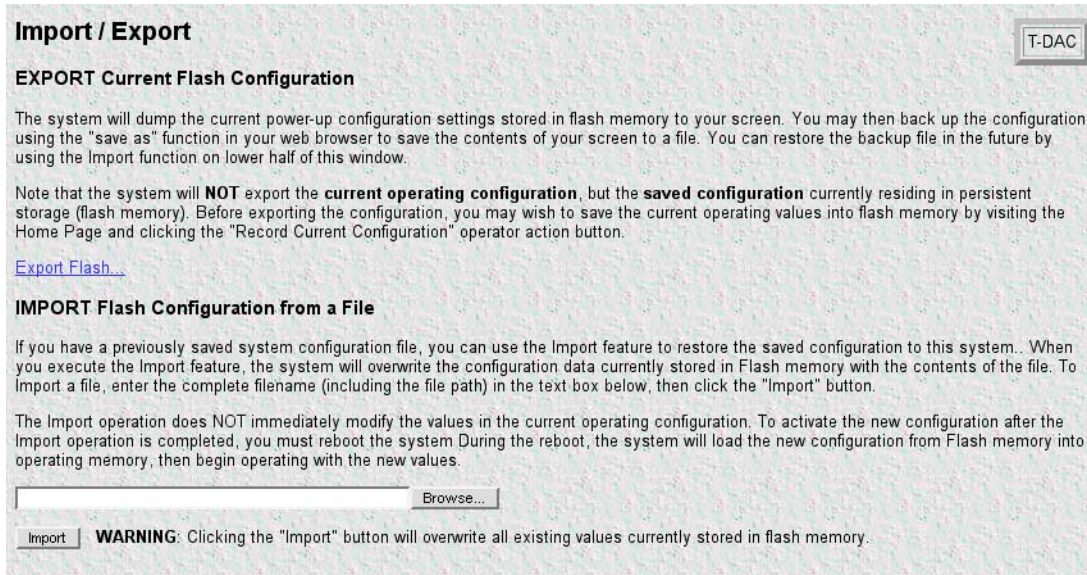

Figure 51. IMPORT/EXPORT page

Note If the T-DAC does not behave as described, the most likely cause is that the T-DAC default settings are not compatible with the T1/E1 line. If this is the case, use the RS-232 CONFIG port to correct the T-DAC settings. You will have to use the 2616RC Configuration Menu pages to examine the configured T1/E1 link settings.

6. There are two LEDs that indicate the status of the T-DAC 10/100 Ethernet port: a green LED indicates link status and activity, and a yellow LED that indicates line speed. Verify that the green LED is either flashing green (meaning that packets are being received at the Ethernet port) or solid green (meaning that the link is valid but no packets are being received).

Congratulations! Your T-DAC is now installed. If you require further information about configuring your T-DAC settings, refer to the *DSL T-DAC Administrator's Reference Guide* available online at www.patton.com/manuals/TDAC-arg.pdf.

Note For information on activating and de-activating your Model 2616RC T-DAC, refer to Chapter 4, "Operation and shutdown".

Chapter 4 **Operation and shutdown**

Chapter contents

Introduction.....59
Activating the Model 2616RC.....59
De-activating the Model 2616RC59

Introduction

This chapter describes how to start up and power down the Model 2616RC.

Activating the Model 2616RC

The Model 2616RC is activated by completing the procedures in Chapter 2, “Hardware installation” and Chapter 3, “Configuring the T-DAC for operation”. To activate the 2616RC, please follow the procedures in those chapters.

The Model 2616RC is designed for unattended operation. Once the Model 2616RC has been installed and configured, no further operator action is required under normal conditions.

De-activating the Model 2616RC

Perform the following procedure to deactivate the Model 2616RC.

Note Be sure to wear an anti-static strap to prevent electrostatic damage to the blade.

1. Unlock the handles on the front of the 2616RC by pressing the red button on each handle. The button immediately activates the switch (turning it to an open position), while the button itself remains depressed. Remove the blade by pushing the handles outwards.
2. Remove the Model 2616RC from the rack chassis. Place the blade on an anti-static surface.
3. Remove the rear blade from the rack chassis. Place the blade on an anti-static surface.

Chapter 5 **Troubleshooting and maintenance**

Chapter contents

Introduction.....	61
Fault analysis.....	62
T1/E1 port test modes.....	64
DSX1 payload loop (dsx1PayloadLoop)	64
DSX1 line loop (dsxLineLoop)	65
Periodic maintenance	66
Calibration	66
Maintenance.....	66
Exporting the current Model 2616RC configuration	66
Removing the defective Model 2616RC	69
Installing the replacement Model 2616RC	70
Importing a saved configuration	70
Completing the installation	71

Introduction

This chapter describes troubleshooting and fault analysis that can be performed by the operator. If you require more help, refer to Chapter 6, “Contacting Patton for assistance”. Refer to [table 6](#) for a list of common symptoms and suggested remedies.

- Note** The following information assumes that there is only one failure involving the Model 2616RC and that if you perform the corrective action listed, it will solve the problem. If you are unable to correct a failure, refer to Chapter 6, “Contacting Patton for assistance”.
- Note** When removing the 2616RC from the chassis, follow the procedures cited in “[De-activating the Model 2616RC](#)” on page 59.
- Note** When re-inserting the 2616RC into the chassis, please follow the procedures cited in “[T-DAC blades installation](#)” on page 20.

Table 6. Symptoms

Problem	Corrective Action
<i>POWER LED</i> (green) is extinguished	To verify that power is being supplied to the Model 2616RC via the Patton ForeFront chassis power bus: verify that at least one chassis power supply module is installed in the chassis and functioning normally.
<i>POWER LED</i> (green) is flashing	The 2616RC has detected a power failure on a power bus. There may be a problem with the Patton ForeFront chassis power system which feeds the Model 2616RC such as a failed power supply module in the chassis. The Model 2616RC will function normally with one power supply. Inspect the power supplies in the Patton ForeFront chassis to identify and replace the failed power supply module. If no failed power supply is found, or if the <i>POWER LED</i> continues flashing, contact Patton Technical Support to determine if the T-DAC should be replaced.
<i>CPU FAIL LED</i> (red) is lit	CPU is unable to load the software from FLASH to RAM for operation. As soon as possible, remove the Model 2616RC from the Patton ForeFront chassis, wait 30 seconds, then re-insert the Model 2616RC into the Patton ForeFront chassis and see if the problem disappears. If the <i>CPU FAIL LED</i> remains lit after the Model 2616RC completes the power-up cycle, contact Patton Technical Support to determine if the T-DAC needs to be replaced.
<i>ALARM LED</i> (yellow) is lit	Indicates The 2616RC has detected a minor or major alarm condition.
<i>SYSTEM LED</i> (green) is not flashing	The Model 2616RC is not functioning properly. As soon as possible, remove the Model 2616RC from the Patton ForeFront chassis, wait 30 seconds, then re-insert the Model 2616RC into the Patton ForeFront chassis and see if the problem disappears. If the <i>SYSTEM LED</i> remains lit after the Model 2616RC completes the power-up cycle, contact Patton Technical Support to determine if the T-DAC needs to be replaced.
<i>ETHERNET LED</i> (green) is extinguished	<ul style="list-style-type: none"> • A valid Ethernet link has not been detected. Verify that the Model 2616RC is connected by means of an Ethernet cable to an Ethernet hub, switch, or workstation and that both ends of the cable are plugged in. • Verify that the hub, switch, or workstation is powered on. • Verify that the correct cable is being used—either a straight through or cross-over cable depending on whether you are connecting to a workstation (PC), hub, or switch. • Replace the Ethernet cable. If the problem still exists, contact Patton Technical Support to determine if the T-DAC should be replaced.

Fault analysis

The following procedures outline steps you should follow when troubleshooting a Model 2616RC malfunction.

1. If possible, talk to the person who filed the trouble complaint and determine the operational symptoms. Record the symptoms on the appropriate trouble report form (include the front panel LED indications).
2. Refer to [table 7](#) for LED definitions and compare the recorded results from the trouble report against those in the table, then refer to the section recommended in the table for the maintenance procedure that will repair the malfunction.

Table 7. LED definitions

LED	Location	Color	Status	Meaning
POWER	Front panel	Green	On solid	Power is being applied. No action recommended.
			Flashing	The 2616RC has detected a power failure on a power bus. There may be a problem with the Patton ForeFront chassis power supply system such as a failed power supply module in the chassis. The Model 2616RC will function normally with one power supply. Inspect the power supplies in the Patton ForeFront chassis to identify and replace the failed power supply module. If the POWER LED continues flashing when all chassis power supplies are functional, contact Patton Technical Support to determine if the T-DAC should be replaced.
			Off	No input power is being applied. Verify that at least one chassis power supply module is installed in the chassis and functioning normally.
CPU FAIL	Front panel	Red	On solid	CPU is unable to load the software from FLASH to RAM for operation. As soon as possible, remove the Model 2616RC from the Patton ForeFront chassis, wait 30 seconds, then reinsert the Model 2616RC into the Patton ForeFront chassis and see if the problem disappears. If the CPU FAIL LED remains lit after the Model 2616RC completes the power-up cycle, contact Patton Technical Support to determine if the T-DAC needs to be replaced.
			Off	The CPU is operating normally. No action recommended.
ALARM	Front panel	Red	On solid	A minor alarm condition has been detected.
			Flashing	A major alarm condition has been detected.
			Off	The Model 2616RC is operating normally. No action recommended.

Table 7. LED definitions (Continued)

LED	Location	Color	Status	Meaning
SYSTEM	Front panel	Green	Flashing	The Model 2616RC is operating normally. No action recommended.
			Off	The Model 2616RC is not functioning properly. As soon as possible, unplug both power cables from the Model 2616RC, wait 30 seconds, then plug the cables back into the Mode 2616RC to see if the problem disappears. If the SYSTEM LED remains lit after the Model 2616RC completes the power-up cycle, contact Patton Technical Support to determine whether the T-DAC needs to be replaced.
ETHERNET	Front panel	Green	On solid	Link status is nominal for the Ethernet port. No action recommended.
			Off	<ul style="list-style-type: none"> • A valid link has not been detected. • Verify that an Ethernet cable is plugged into the hub, switch, or workstation and the Ethernet port of the Model 2616RC. • Verify that the hub, switch, or workstation is powered on. • Verify that the correct straight-through or cross-over cable is being used, depending on whether you are connecting to a workstation (PC), hub, or switch. • Replace the cable. If the problem still exists, contact Patton Technical Support to determine if the T-DAC should be replaced.
CLK SOURCE	Front panel	Green	On solid	The 2616RC is set as the Master Clock source. No action recommended.
			Flashing	The 2616RC is set as the secondary clock source. No action recommended.
			Off	The 2616RC is set as the slave, getting its clock from the H.110 Bus. No action recommended.
CLK ERROR	Front panel	Yellow	On solid	Master Clock source has been lost and the 2616RC is using the secondary source for its clock.
			Flashing	Master Clock source and the Secondary Clock source have been lost and the 2616RC is using its internal crystal for its clock.
			Off	No clock errors currently detected. No action recommended.
TEST MODE	Front panel	Green	On solid	One or more T1/E1 ports or T1/E1 ports is in test mode. No action recommended.
			Flashing	One or more of the T1/E1 ports or the T1/E1 ports is in test mode and errors have been received.
			Off	None of the T1/E1 ports is operating in test mode. No action recommended.
T1/E1 CONNECTIONS (LEDs 1–16)	Front Panel	Green	On solid	The ports are activated, linked, and operating normally.
			Flashing	One or more T1/E1 ports have errors.
			Off	No T1/E1 ports have been configured to establish a link. See Chapter 3, "Configuring the T-DAC for operation" on page 31 to configure the T1/E1 ports.

Table 7. LED definitions (Continued)

LED	Location	Color	Status	Meaning
READY	Front panel	Blue	On	Card ready for removal from Patton ForeFront chassis.
			Off	Card not ready for removal from Patton ForeFront chassis. Do not remove card from chassis.
ALARM	Rear blade	Yellow	On solid	A minor alarm condition has been detected.
			Flashing	A major alarm condition has been detected.
			Off	The Model 2616RC is operating normally. No action recommended.
READY	Rear blade	Blue	On	Card ready for removal from Patton ForeFront chassis.
			Off	Card not ready for removal from Patton ForeFront chassis. Do not remove card from chassis.

T1/E1 port test modes

The 2616RC offers a number of diagnostics tools to test operation and performance of the T1/E1 ports and line. Diagnostics include DSX1 payload loop and DSX1 line loop.

DSX1 payload loop (*dsx1PayloadLoop*)

When activated, the received signal at the selected T1/E1 port, will be looped through the 2616RC (see figure 54). Typically the received signal is looped back for retransmission after it has passed through the device's framing function (framing is terminated and then regenerated).

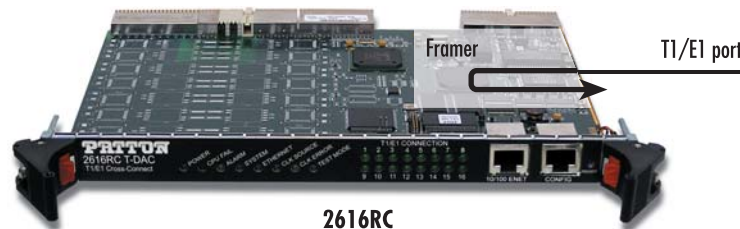

Figure 54. Payload loopback

To activate payload loop, do the following:

1. Click on the *Modify Configuration* link of the T1/E1 port to be placed under test
2. Locate the *Loopback Configuration* drop down menu
3. Select *Payload Loop* and click on the **Submit Query** button on the right.

To deactivate payload loop, set the *Loopback Configuration* drop down menu to *NoLoop*.

Test Settings

Force Yellow Alarm: linkYellowDisable(3) Submit Query

Loopback Configuration: dsx1PayloadLoop(2) Submit Query

Send Code: dsx1SendNoCode(1) Submit Query

DSX1 line loop (*dsxLineLoop*)

When activated, data received at the selected T1/E1 port, is looped back to the originating device (see figure 55). Data is looped at the T1/E1 port.



Figure 55. Line Loop

To activate line loop, do the following:

1. Click on the *Modify Configuration* link of the T1/E1 port to be placed under test.
2. Locate the *Loopback Configuration* drop down menu
3. Select *LineLoop* and click on the **Submit Query** button on the right.

To deactivate payload loop, set the *Loopback Configuration* drop down menu to *NoLoop*, and click on the **Submit Query** button on the right.

Submit Query

Test Settings

Force Yellow Alarm: linkYellowDisable(3) Submit Query

Loopback Configuration: dsx1LineLoop(3) Submit Query

Send Code: dsx1SendNoCode(1) Submit Query

Note Refer to the *Administration Reference Guide* for descriptions of yellow alarms and send codes.

Periodic maintenance

Consult the rack chassis user manual for information on preventative maintenance (such as cleaning the chassis air cooling vents to remove accumulated dust).

Calibration

The Model 2616RC requires no calibration.

Maintenance

If you isolate a problem to the a Model 2616RC component, the entire Model 2616RC must be replaced as follows.

Exporting the current Model 2616RC configuration

The 2616RC T-DAC provides Import/Export functions. These functions enable you to back up (*export*) and restore (*import*) your T-DAC's configuration parameters against possible failure. Should your T-DAC ever need replacing, a previously saved copy of your (*exported*) configuration file can quickly be loaded (*imported*) into a replacement T-DAC.

Note Import/Export functions require superuser access privileges.

Note The parameters that will be exported are the power-up settings as they are stored in flash memory and may not be the current operating parameters. To ensure that you export the most current parameters, go to HOME, then under Operator Actions, click on the **Record Current Configuration** button.

1. If you already have an exported backup copy of your current configuration, go to [“Removing the defective Model 2616RC”](#) on page 69. Otherwise, go to step 2.
2. On the Configuration Menu pane, click the *Import/Export* hyperlink to display the **Import/Export** page ([figure 56](#)).

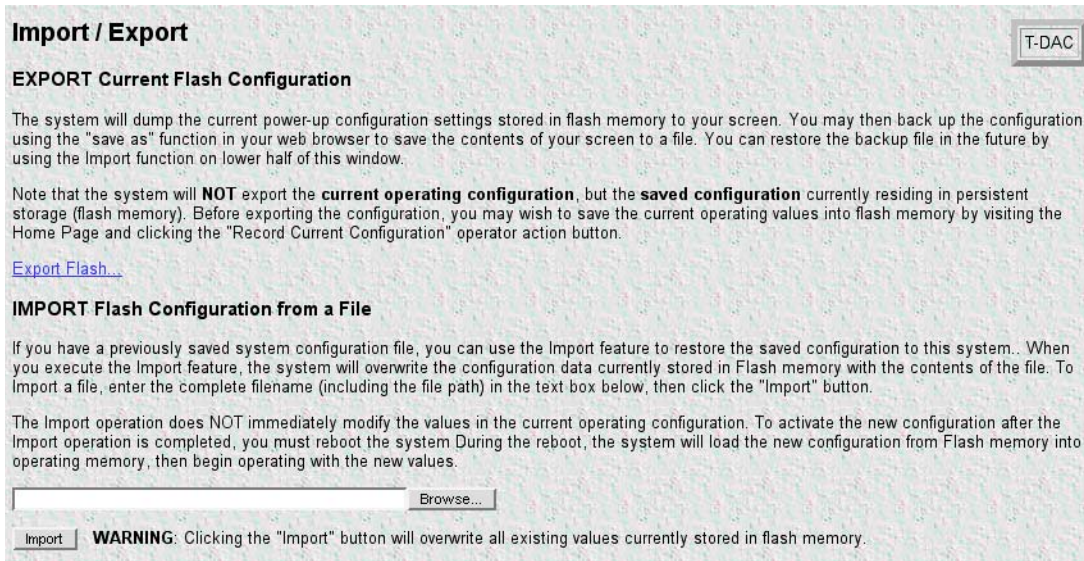

Import / Export T-DAC

EXPORT Current Flash Configuration

The system will dump the current power-up configuration settings stored in flash memory to your screen. You may then back up the configuration using the "save as" function in your web browser to save the contents of your screen to a file. You can restore the backup file in the future by using the Import function on lower half of this window.

Note that the system will **NOT** export the **current operating configuration**, but the **saved configuration** currently residing in persistent storage (flash memory). Before exporting the configuration, you may wish to save the current operating values into flash memory by visiting the Home Page and clicking the "Record Current Configuration" operator action button.

[Export Flash...](#)

IMPORT Flash Configuration from a File

If you have a previously saved system configuration file, you can use the Import feature to restore the saved configuration to this system. When you execute the Import feature, the system will overwrite the configuration data currently stored in Flash memory with the contents of the file. To Import a file, enter the complete filename (including the file path) in the text box below, then click the "Import" button.

The Import operation does NOT immediately modify the values in the current operating configuration. To activate the new configuration after the Import operation is completed, you must reboot the system. During the reboot, the system will load the new configuration from Flash memory into operating memory, then begin operating with the new values.

WARNING: Clicking the "Import" button will overwrite all existing values currently stored in flash memory.

Figure 56. IMPORT/EXPORT page

3. Unlock the handles by pressing the red button on each handle. The button immediately activates the switch (turning it to an open position), while the button itself remains depressed. The blade can then be removed.
4. Remove the malfunctioning Model 2616RC by pushing the handles outwards, pulling the card gently but firmly from its slot in the chassis. Place the removed card in the container the replacement Model 2616RC came in so you can return the defective Model 2616RC for repair.

Installing the replacement Model 2616RC

1. Insert the replacement Model 2616RC into the rack chassis.
2. Insert the rear blade into the desired slot in the rack chassis. Make sure the blade is seated properly in the slot guides.
3. Gently press the blade into the chassis until the alignment/ESD pin engages the chassis. When the blade is fully seated, the red buttons in the handles click up automatically, thus locking the handle and activating the switch (closed position). The click of the button gives a visual and audible confirmation that the board is fully seated.
4. Connect the following cables to the Model 2616RC:
 - The T1/E1 WAN cable (68-pin SCSI connector)
 - The RS-232 CONFIG cable
 - The 10/100 ETHERNET cable
5. Verify that the green *POWER* LED is lit.

Importing a saved configuration

Before importing a saved configuration, you must define the Model 2616RC's IP address and netmask. These parameters are defined via the Model 2616RC RS-232 CONFIG port on the Model 2616RC.

1. Refer to Chapter 3, "Configuring the T-DAC for operation" and follow the procedures contained in section "Initial configuration through the RS-232 control port" on page 33.
2. To import a saved configuration, connect your Web browser to the Administration Pages, then click on *Import/Export* under the Configuration Menu to display the **Import/Export** page (figure 56 on page 67).
3. To import a configuration file into the Model 2616RC, type the complete path and filename for the configuration file you wish to load or click on the **Browse...** button to select the desired file, then click the **Submit Query** button.

Upon successfully importing the file, the Model 2616RC will display *Configuration Load Complete*, indicating that the new operating parameters have been loaded into flash memory.

4. On the Configuration Menu, click the *HOME* hyperlink, then click the **Hard Reset** button under *Operator Actions*.

Note *Do not* select **Record Current Configuration** after importing configuration parameters.

Completing the installation

This section verifies that the Model 2616RC is fully operational.

1. Verify that the green *POWER* LED is lit. If the *POWER* LED is flashing green, refer to Chapter 5, “[Troubleshooting and maintenance](#)” on page 60.
2. Verify that the *WAN* LED illuminates, indicating that the Model 2616RC is synchronizing with the T1/E1 signal.
3. Verify that after 5 seconds, the *WAN* LED begins flashing, indicating that the Model 2616RC is satisfied with the quality of the T1/E1 signal.
4. Verify that after 10 seconds, the *WAN* LED extinguishes, indicating that the Model 2616RC is satisfied with the network signal and that the link is ready for use.
5. Verify that the green Ethernet LED is either flashing (indicating link status is nominal for the front Ethernet port) or on solid (indicating that link status is nominal for at least one of the Ethernet backplane connections).

The Model 2616RC is operational.

Chapter 6 **Contacting Patton for assistance**

Chapter contents

- Introduction.....73
- Contact information.....73
- Warranty Service and Returned Merchandise Authorizations (RMAs).....73
 - Warranty coverage73
 - Out-of-warranty service73
 - Returns for credit73
 - Return for credit policy74
- RMA numbers74
 - Shipping instructions74

Introduction

This chapter contains the following information:

- “Contact information”—describes how to contact PATTON technical support for assistance.
- “Warranty Service and Returned Merchandise Authorizations (RMAs)” —contains information about the RAS warranty and obtaining a return merchandise authorization (RMA).

Contact information

Patton Electronics offers a wide array of free technical services. If you have questions about any of our other products we recommend you begin your search for answers by using our technical knowledge base. Here, we have gathered together many of the more commonly asked questions and compiled them into a searchable database to help you quickly solve your problems.

- Online support—available at www.patton.com.
- E-mail support—e-mail sent to support@patton.com will be answered within 1 business day
- Telephone support—standard telephone support is available Monday through Friday, from 8:00 A.M. to 5:00 P.M. EST (8:00 to 17:00 UTC-5), Monday through Friday by calling +1 (301) 975-1007

Warranty Service and Returned Merchandise Authorizations (RMAs)

Patton Electronics is an ISO-9001 certified manufacturer and our products are carefully tested before shipment. All of our products are backed by a comprehensive warranty program.

Note If you purchased your equipment from a Patton Electronics reseller, ask your reseller how you should proceed with warranty service. It is often more convenient for you to work with your local reseller to obtain a replacement. Patton services our products no matter how you acquired them.

Warranty coverage

Our products are under warranty to be free from defects, and we will, at our option, repair or replace the product should it fail within one year from the first date of shipment. Our warranty is limited to defects in workmanship or materials, and does not cover customer damage, lightning or power surge damage, abuse, or unauthorized modification.

Out-of-warranty service

Patton services what we sell, no matter how you acquired it, including malfunctioning products that are no longer under warranty. Our products have a flat fee for repairs. Units damaged by lightning or elephants may require replacement.

Returns for credit

Customer satisfaction is important to us, therefore any product may be returned with authorization within 30 days from the shipment date for a full credit of the purchase price. If you have ordered the wrong equipment or you are dissatisfied in any way, please contact us to request an RMA number to accept your return. Patton is not responsible for equipment returned without a Return Authorization.

Return for credit policy

- Less than 30 days: No Charge. Your credit will be issued upon receipt and inspection of the equipment.
- 30 to 120 days: We will add a 20% restocking charge (crediting your account with 80% of the purchase price).
- Over 120 days: Products will be accepted for repairs only.

RMA numbers

RMA numbers are required for all product returns. You can obtain an RMA by doing one of the following:

- Completing a request on the RMA Request page in the *Support* section at www.patton.com
- By calling +1 (301) 975-1000 and speaking to a Technical Support Engineer
- By sending an e-mail to returns@patton.com

All returned units must have the RMA number clearly visible on the outside of the shipping container. Please use the original packing material that the device came in or pack the unit securely to avoid damage during shipping.

Shipping instructions

The RMA number should be clearly visible on the address label. Our shipping address is as follows:

Patton Electronics Company

RMA#: xxxx

7622 Rickenbacker Dr.

Gaithersburg, MD 20879-4773 USA

Patton will ship the equipment back to you in the same manner you ship it to us. Patton will pay the return shipping costs.

Appendix A **Compliance information**

Chapter contents

Compliance	76
EMC	76
Safety	76
PSTN Regulatory	76
Radio and TV Interference	76
Industry Canada Notice	76
FCC Part 68 (ACTA) Statement	77
CE Declaration of Conformity	77
Authorized European Representative	77

Compliance

EMC

- FCC Part 15, Class A
- EN55022, Class A
- EN55024

Safety

- UL60950-1/CSA C22.2 No. 60950-1
- IEC/EN 60950-1
- AS/NZS 60950-1

PSTN Regulatory

- FCC Part 68
- CS-03

Radio and TV Interference

This equipment generates and uses radio frequency energy, and if not installed and used properly—that is, in strict accordance with the manufacturer's instructions—may cause interference to radio and television reception. This equipment has been tested and found to comply with the limits for a Class A computing device in accordance with the specifications in Subpart B of Part 15 of FCC rules, which are designed to provide reasonable protection from such interference in a commercial installation. However, there is no guarantee that interference will not occur in a particular installation. If the equipment causes interference to radio or television reception, which can be determined by disconnecting the cables, try to correct the interference by one or more of the following measures: moving the computing equipment away from the receiver, re-orienting the receiving antenna, and/or plugging the receiving equipment into a different AC outlet (such that the computing equipment and receiver are on different branches).

Industry Canada Notice

This equipment meets the applicable Industry Canada Terminal Equipment Technical Specifications. This is confirmed by the registration number. The abbreviation, *IC*, before the registration number signifies that registration was performed based on a Declaration of Conformity indicating that Industry Canada technical specifications were met. It does not imply that Industry Canada approved the equipment.

This Declaration of Conformity means that the equipment meets certain telecommunications network protective, operational and safety requirements. The Department does not guarantee the equipment will operate to the user's satisfaction. Before installing this equipment, users should ensure that it is permissible to be connected to the facilities of the local telecommunications company. The equipment must also be installed using an acceptable method of connection. In some cases, the company's inside wiring associated with a single line individual service may be extended by means of a certified connector assembly (telephone extension cord). The customer should be aware that compliance with the above condition may not prevent degradation of service in some situations. Repairs to some certified equipment should be made by an authorized maintenance facility

designated by the supplier. Any repairs or alterations made by the user to this equipment, or equipment malfunctions, may give the telecommunications company cause to request the user to disconnect the equipment. Users should ensure for their own protection that the ground connections of the power utility, telephone lines and internal metallic water pipe system, are connected together. This protection may be particularly important in rural areas.

FCC Part 68 (ACTA) Statement

This equipment complies with Part 68 of FCC rules and the requirements adopted by ACTA. On the bottom side of this equipment is a label that contains—among other information—a product identifier in the format *US: AAAEQ##TXXXX*. If requested, this number must be provided to the telephone company.

The method used to connect this equipment to the premises wiring and telephone network must comply with the applicable FCC Part 68 rules and requirements adopted by the ACTA.

If this equipment causes harm to the telephone network, the telephone company will notify you in advance that temporary discontinuance of service may be required. But if advance notice isn't practical, the telephone company will notify the customer as soon as possible. Also, you will be advised of your right to file a complaint with the FCC if you believe it is necessary.

The telephone company may make changes in its facilities, equipment, operations or procedures that could affect the operation of the equipment. If this happens the telephone company will provide advance notice in order for you to make necessary modifications to maintain uninterrupted service.

If trouble is experienced with this equipment, for repair or warranty information, please contact our company. If the equipment is causing harm to the telephone network, the telephone company may request that you disconnect the equipment until the problem is resolved.

Connection to party line service is subject to state tariffs. Contact the state public utility commission, public service commission or corporation commission for information.

CE Declaration of Conformity

We certify that the apparatus identified in this document conforms to the requirements of Council Directive 1999/5/EC on the approximation of the laws of the member states relating to Radio and Telecommunication Terminal Equipment and the mutual recognition of their conformity.

The safety advice in the documentation accompanying this product shall be obeyed. The conformity to the above directive is indicated by the CE sign on the device.

Authorized European Representative

D R M Green

European Compliance Services Limited.

Oakdene House, Oak Road

Watchfield, Swindon, Wilts SN6 8TD, UK

Appendix B **68-pin SCSI-to-open-end 6-foot cable (part # 10-3096TM68-6)**

Chapter contents

Introduction	79
--------------------	----

Introduction

The SCSI-to-open-end cable connects the 2616RC T1/E1 lines to a punch-down block via 24 gauge solid wire (0.5mm). Refer to [table 8](#) for punch-down block wiring information.

Table 8. WAN cable's 68 non-terminated twisted-pairs

Port/Direction	Pairs	68 Pin Positions	Wire Color Code
Port 1/TX	1	1 35	White/Tan Tan/White
Port 1/RX	2	2 36	White/Brown Brown/White
Port 2/TX	3	3 37	White/Pink Pink/White
Port 2/RX	4	4 38	White/Orange Orange/White
Port 3/TX	5	5 39	White/Violet Violet/White
Port 3/RX	6	6 40	White/Blue Blue/White
Port 4/TX	7	7 41	White/Yellow Yellow/White
Port 4/RX	8	8 42	White/Green Green/White
Port 5/TX	9	9 43	White/Gray Gray/White
Port 5/RX	10	10 44	Tan/Brown Brown/Tan
Port 6/TX	11	11 45	Tan/Pink Pink/Tan
Port 6/RX	12	12 46	Tan/Orange Orange/Tan
Port 7/TX	13	13 47	Tan/Violet Violet/Tan
Port 7/RX	14	14 48	Tan/Blue Blue/Tan
Port 8/TX	15	15 49	Tan/Yellow Yellow/Tan
Port 8/RX	16	16 50	Tan/Green Green/Tan
	—	33 67	NOT USED

Port/Direction	Pairs	68 Pin Positions	Wire Color Code
Port 9/TX	17	17 51	Tan/Gray Gray/Tan
Port 9/RX	18	18 52	Brown/Pink Pink/Brown
Port 10/TX	19	19 53	Brown/Orange Orange/Brown
Port 10/RX	20	20 54	Brown/Violet Violet/Brown
Port 11/TX	21	21 55	Brown/Blue Blue/Brown
Port 11/RX	22	22 56	Brown/Yellow Yellow/Brown
Port 12/TX	23	23 57	Brown/Green Green/Brown
Port 12/RX	24	24 58	Brown/Gray Gray/Brown
Port 13/TX	25	25 59	Pink/Orange Orange/Pink
Port 13/RX	26	26 60	Pink/Violet Violet/Pink
Port 14/TX	27	27 61	Pink/Blue Blue/Pink
Port 14/RX	28	28 62	Pink/Yellow Yellow/Pink
Port 15/TX	29	29 63	Pink/Green Green/Pink
Port 15/RX	30	30 64	Pink/Gray Gray/Pink
Port 16/TX	31	31 65	Orange/Violet Violet/Orange
Port 16/RX	32	32 66	Orange/Blue Violet/Blue
	—	34 68	NOT USED

