

# USER MANUAL

## MODEL 2701/B, C, D G.703/G.704 NTU with EIA-530, V.35, X.21 Interfaces



**Important** — This is a Class A device and is intended for use in a light industrial environment. It is not intended nor approved for use in an industrial or residential environment.

**PATTON**  
Electronics Co.



Part# 07M2701-UM  
Doc# 08610U2-001  
Rev. E  
Revised 6/18/07

SALES OFFICE  
(301) 975-1000  
TECHNICAL SUPPORT  
(301) 975-1007

## CONTENTS

<b>1.0</b>	<b>Warranty &amp; Compliance Information .....</b>	<b>4</b>
1.1	Compliance .....	4
	EMC Compliance.....	4
	Safety Compliance: .....	4
	PSTN Regulatory Compliance:.....	4
1.2	CE Notice.....	5
1.3	Authorized European Representative .....	5
1.4	Service .....	5
1.5	Safety When Working With Electricity .....	6
<b>2.0</b>	<b>General Information.....</b>	<b>7</b>
2.1	Features.....	7
2.2	Description.....	7
<b>3.0</b>	<b>Configuration .....</b>	<b>8</b>
3.1	DIP Switch Configuration.....	8
	Switch SW1-1 through SW1-5.....	9
	SW1-6 and SW1-7 Clock Modes.....	10
	SW1-8: Enable/Disable Loop Tests from DTE .....	11
	Switch SW2-1 Line Coding: HDB3 (default) .....	11
	Switch SW2-2: CRC-4 Multiframe .....	12
	Switch SW2-3 Data Inversion.....	12
	Switch SW2-4: Remote Digital Loopback Type .....	13
	Switch SW2-5 Front Panel Switches .....	13
	Switch SW2-6: V.54 Response Disabled (default) .....	13
<b>4.0</b>	<b>Installation.....</b>	<b>14</b>
4.1	Connecting to the G.703 Network.....	14
	Connecting the 2701/D (X.21 version) Dual Coaxial Cable (75 ohm) to the G.703 Network .....	14
	Opening the Case.....	14
	Connecting the Twisted Pair (120 ohm) to the G.703 Network ..	15
4.2	Connecting the Serial Port.....	15
	Connecting to a "DTE" Device.....	15
	Connecting to a "DCE" Device .....	16
	Configuring the X.21 Interface (2701/D).....	16
4.3	Power Connection .....	16
	Universal AC Power (100–240 VAC).....	16
	DC Power .....	17
<b>5.0</b>	<b>Operation.....</b>	<b>18</b>
5.1	Power-up .....	18
5.2	LED Status Monitors.....	18
5.3	Loop (V.54 & Telco) Diagnostics .....	19
	Operating Local Loopback (LL) .....	19
	Operating Remote Digital Loopback (RL).....	20
	CSU Loop.....	21
	Using the V.52 (BER) Test Pattern Generator .....	22

<b>A</b>	<b>Specifications .....</b>	<b>23</b>
A.1	Network Data Rate .....	23
A.2	Network Connector .....	23
A.3	Nominal Impedance .....	23
A.4	Line Coding .....	23
A.5	Line Framing .....	23
A.6	CRC-4 Multiframeing .....	23
A.7	Clocking .....	23
A.8	Time Slot Rate .....	23
A.9	Network Data Rates .....	23
A.10	Distance .....	23
A.11	Configuration .....	23
A.12	Power Supply .....	24
A.13	Humidity .....	24
A.14	Temperature .....	24
A.15	Dimensions .....	24
<b>B</b>	<b>Interface Pin Assignment.....</b>	<b>25</b>
<b>C</b>	<b>Interface Pin Assignment.....</b>	<b>27</b>
<b>D</b>	<b>Interface Pin Assignment.....</b>	<b>29</b>
<b>E</b>	<b>Factory Replacement Parts and Accessories.....</b>	<b>30</b>

## **1.0 WARRANTY & COMPLIANCE INFORMATION**

Patton Electronics warrants all Model 2701/l components to be free from defects, and will—at our option—repair or replace the product should it fail within one year from the first date of shipment.

This warranty is limited to defects in workmanship or materials, and does not cover customer damage, abuse, or unauthorized modification. If this product fails or does not perform as warranted, your sole recourse shall be repair or replacement as described above. Under no condition shall Patton Electronics be liable for any damages incurred by the use of this product. These damages include, but are not limited to, the following: lost profits, lost savings and incidental or consequential damages arising from the use of or inability to use this product. Patton Electronics specifically disclaims all other warranties, expressed or implied, and the installation or use of this product shall be deemed an acceptance of these terms by the user.

### **1.1 COMPLIANCE**

#### **EMC Compliance**

- EN55022, Class A
- EN55024

#### **Safety Compliance:**

- EN 60950-1
- AS/NZS 60950-1

#### **PSTN Regulatory Compliance:**

- TBR 12 & 13
- AS/ACIF S016:2001

## **1.2 CE NOTICE**

We certify that the apparatus identified in this document conforms to the requirements of Council Directive 1999/5/EC on the approximation of the laws of the member states relating to Radio and Telecommunication Terminal Equipment and the mutual recognition of their conformity.

The safety advice in the documentation accompanying this product shall be obeyed. The conformity to the above directive is indicated by the CE sign on the device.

## **1.3 AUTHORIZED EUROPEAN REPRESENTATIVE**

D R M Green

European Compliance Services Limited.

Oakdene House, Oak Road

Watchfield, Swindon, Wilts SN6 8TD, UK

## **1.4 SERVICE**

All warranty and non-warranty repairs must be returned freight prepaid and insured to Patton Electronics. All returns must have a Return Materials Authorization number on the outside of the shipping container. This number may be obtained from Patton Electronics Technical Services at:

- Tel: **+1 (301) 975-1007**
- Email: **support@patton.com**
- URL: **http://www.patton.com**

**Note** Packages received without an RMA number will not be accepted.

## 1.5 SAFETY WHEN WORKING WITH ELECTRICITY



- This device contains no user serviceable parts. The equipment shall be returned to Patton Electronics for repairs, or repaired by qualified service personnel.
- The external power adapter shall be a listed Limited Power Source. Ensure that the power cable used meets all applicable standards for the country in which it is to be installed, and that it is connected to a wall outlet which has earth ground. The mains outlet that is utilized to power the device shall be within 10 feet (3 meters) of the device, shall be easily accessible, and protected by a circuit breaker.
- Hazardous network voltages are present in WAN ports regardless of whether power to the unit is ON or OFF. To avoid electric shock, use caution when near WAN ports. When detaching the cables, detach the end away from the device first.
- Do not work on the system or connect or disconnect cables during periods of lightning activity.



In accordance with the requirements of council directive 2002/96/EC on Waste of Electrical and Electronic Equipment (WEEE), ensure that at end-of-life you separate this product from other waste and scrap and deliver to the WEEE collection system in your country for recycling.

## **2.0 GENERAL INFORMATION**

Thank you for your purchase of this Patton Electronics product. This product has been thoroughly inspected and tested and is warranted for One Year parts and labor. If any questions or problems arise during installation or use of this product, please do not hesitate to contact Patton Electronics Technical Support at (301) 975-1007.

### **2.1 FEATURES**

- Terminates G.703 and G.704, E1/fractional E1 service
- Available in low-cost standalone or rack-mountable versions
- n x 64 kbps data rates to 2 Mbps
- X.21, V.35, and EIA-530
- Switch-selectable AMI or HDB3 line encoding options
- Switch-selectable DTE/DCE modes for X.21 version
- 75-ohm dual coax and 120-ohm twisted-pair G.703 connections
- Local and remote loopback diagnostics
- Internal, external, and G.703 network timing
- CE and BABT approvals
- 100–240 VAC and 48 VDC power options
- Conforms to ONP requirements CTR 12 and CTR 13 for connection to international Telecom networks

### **2.2 DESCRIPTION**

The Model 2701 receives channelized G.704 (n x 64 kbps) or clear channel E1/G.703 (2.048-Mbps) data from the Telco's digital data network.

The Model 2701 terminates the G.703 telco interface and converts the data for transmission to a user-oriented serial [X.21, V.35, and EIA-530 (V.36/RS422)]. The 2701 can connect to a Router, FRAD, PABX or Multiplexer over its serial interface at nx64kbps data rates up to 2.048 Mbps.

Thank you for your purchase of this Patton Electronics product. This product has been thoroughly inspected and tested and is warranted for One Year parts and labor. If any questions or problems arise during installation or use of this product, contact Patton Electronics Technical Support at (301) 975-1007.

### 3.0 CONFIGURATION

The Model 2701 features configuration capability via hardware DIP switches. This section describes all possible DIP switch configurations of the Model 2701.

#### 3.1 DIP SWITCH CONFIGURATION

The Model 2701 has two sets of internal DIP switches that allow configuration for a wide range of applications. The sets of switches are accessed from the underside of the 2701. Figure 1 shows the location of the DIP switches on the bottom of the printed circuit board.

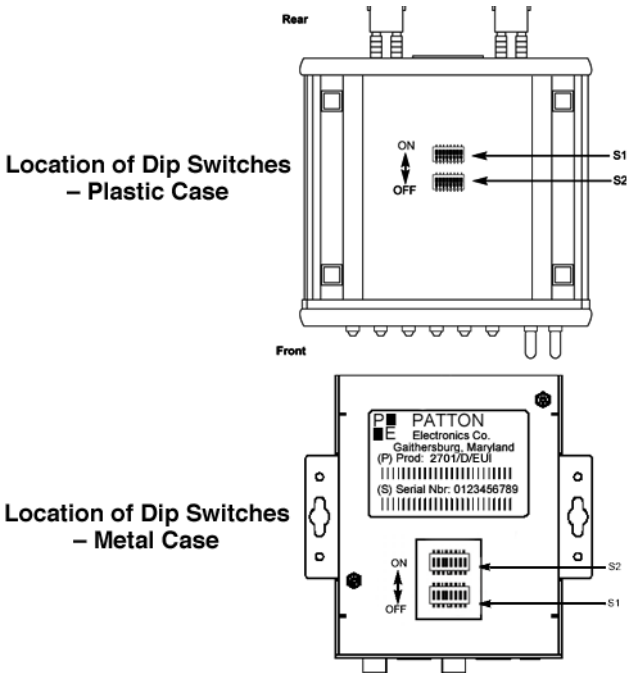

Figure 1. Underside of Model 2701, Showing Location of DIP Switches

The Model 2701 DIP switches (Switch Sets 1–2) can be configured as either “ON” or “OFF”. Figure 2 shows the orientation of the DIP switches with respect to ON/OFF positions.

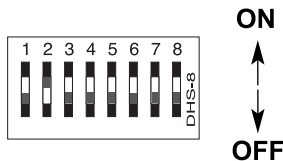

Figure 2. Close up of configuration switches

## Switch SW1-1 through SW1-5

A detailed description of each switch (SW1-1 through SW1-5) setting follows the summary table below.

**Table 1:** Switch Set 1 Summary Table

Position	Function	Factory Default	Selected Option
SW1-1	DTE Rate	OFF	} 2.048 Mbps Clear Channel
SW1-2	DTE Rate	OFF	
SW1-3	DTE Rate	OFF	
SW1-4	DTE Rate	OFF	
SW1-5	DTE Rate	OFF	
SW1-6	Clock Mode	OFF	Receive Recovered
SW1-7	Clock Mode	OFF	Receive Recovered
SW1-8	TM from DTE	OFF	Enabled

Use Switches SW1-5 to set the DTE data rate.

SW1	SW2	SW3	SW4	SW5	Speed
On	On	On	On	On	64 kbps
Off	On	On	On	On	128 kbps
On	Off	On	On	On	192 kbps
Off	Off	On	On	On	256 kbps
On	On	Off	On	On	320 kbps
Off	On	Off	On	On	384 kbps
On	Off	Off	On	On	448 kbps
Off	Off	Off	On	On	512 kbps
On	On	On	Off	On	576 kbps
Off	On	On	Off	On	640 kbps
On	Off	On	Off	On	704 kbps
Off	Off	On	Off	On	768 kbps
On	On	Off	Off	On	832 kbps
Off	On	Off	Off	On	896 kbps
On	Off	Off	Off	On	960 kbps
Off	Off	Off	Off	On	1024 kbps
On	On	On	On	Off	1088 kbps
Off	On	On	On	Off	1152 kbps
On	Off	On	On	Off	1216 kbps
Off	Off	On	On	Off	1280 kbps

SW1	SW2	SW3	SW4	SW5	Speed
On	On	Off	On	Off	1344 kbps
Off	On	Off	On	Off	1408 kbps
On	Off	Off	On	Off	1472 kbps
Off	Off	Off	On	Off	1536 kbps
On	On	On	Off	Off	1600 kbps
Off	On	On	Off	Off	1664 kbps
On	Off	On	Off	Off	1728 kbps
Off	Off	On	Off	Off	1792 kbps
On	On	Off	Off	Off	1856 kbps
Off	On	Off	Off	Off	1920 kbps
On	Off	Off	Off	Off	1984 kbps
Off	Off	Off	Off	Off	Clear Channel 2048 kbps

**Note** When the data rate is set to 2.048Mb/s, the unit is forced into G.703 mode, and it transmits user data on all 32 time-slots. There is no framing information; therefore, the CRC4 MF (SW2-2) switch is ignored. In all other rate settings, the unit employs G.704 framing; TS0 is reserved for signaling.

SW1-6	SW1-7	Clock Mode
On	On	Network (Received Recovered)
On	Off	Internal
Off	On	External
Off	Off	Network (Received Recovered)

### SW1-6 and SW1-7 Clock Modes

Use Switches SW1-6 and SW1-7 to configure the 2701 for internal, external, or receive recover clock mode.

**Network Clock**—Transmitter timing is derived using the received line signal (received recovered) from the network.

**Internal Clock**—Transmitter timing is derived from an internal clock source.

**External Clock**—Transmitter timing is derived from DTE terminal timing.

## SW1-8: Enable/Disable Loop Tests from DTE

Use Switch SW1-8 to allow Model 2701 to enter loopback tests when the DTE raises the appropriate loop request pin.

S1-8	Setting
Off	Response to DTE Loopback Request Enabled
On	Response to DTE Loopback Request Disabled

Position	Function	Factory Default	Selected Option
SW2-1	Line Coding	Off	HDB3
SW2-2	CRC-4 multiframe	Off	Disabled
SW2-3	Data Inversion	Off	Data Not Inverted
SW2-4	V.54/CSU select	Off	V.54 RDL loop
SW2-5	FPS enabled	Off	Enabled
SW2-6	V.54 Response	On	Disabled
SW2-7	Not Used	N/A	N/A
SW2-8	Not Used	N/A	N/A

### Switch SW2-1 Line Coding: HDB3 (default)

Use Switch SW2-1 to control the Network Line Coding options. Set these options to be the same as the Line Coding given to you by your Service Provider. If you are using two Model 2701s together as short range modems, set both units to HDB3.

SW2-1	Line Encoding
Off	HDB3
On	AMI

Options: **HDB3, AMI**

**HDB3** In this line coding, the transmitter substitutes a deliberate bipolar violation when excessive zeros in the data stream are detected. The receiver recognizes these special violations and decodes them as zeros. This method enables the network to meet minimum pulse density requirements. Unless AMI is required in your application, HDB3 should be used whenever possible.

**AMI** Alternate Mark Inversion defines a pulse as a “mark,” a binary one, as opposed to a zero. In an E1 network connection, signals are transmitted as a sequence of ones and zeros. Ones are sent as pulses, and zeros are sent as spaces, i.e., no pulse.

Every other pulse is inverted from the previous pulse in polarity, so that the signal can be effectively transmitted. This means, however, that a long sequence of zeros in the data stream will cause problems, since the NTU receiving the signal relies on the signal to recover the 2.048 Mb/s clock.

If you must use AMI, you should ensure that the data terminal equipment connected to the unit provides a minimally acceptable pulse density. For this reason, there are advantages to using HDB3 instead. AMI coding does not inherently account for ones density. To meet this requirement, the user should ensure that the data inherently meets pulse density requirements.

### Switch SW2-2: CRC-4 Multiframe

In framed mode, SW2-2 is used for CRC-4 MF. When CRC-4 is enabled, the unit monitors the incoming data stream for CRC-4 errors. It transmits CRC-4 error counts to the transmitting unit. When using timeslot zero (TS0), excessive errors may cause loss of frame or loss of sync. If CRC-4 MF is used, both units must be set for set for CRC-4 MF. Otherwise, the one using CRC-4 MF will detect loss of sync.

SW2-2	Option
Off	CRC-4 Disabled
On	CRC-4 Enabled

**Note** When the data rate is set to 2.048Mb/s, then the unit is forced into G.703 mode, and it transmits user data on all 32 time-slots. There is no framing information; therefore, the CRC4 MF (SW2-2) switch is ignored. In all other rate settings, the unit employs G.704 framing; TS0 is reserved for signaling.

### Switch SW2-3 Data Inversion

Set Switch S2-3 to determine whether or not the data stream from the local DTE is inverted within the Model 2701 before being passed to the G.703/G.704 network. An inverted data stream may be required when you use the Model 2701 to communicate with a G.703 device (that inverts the data) on the remote end. In typical installations, data inversion is not necessary.

SW2-3	Option
Off	Data not inverted
On	Data inverted

**Switch SW2-4: Remote Digital Loopback Type**

The user can set this switch to select the type of remote loop that will be initiated by the Model 2701. If set to V.54, the Model 2701 will initiate a V.54 loop when Remote Loop is selected by the front panel switches. If set to CSU, the Model 2701 will initiate a CSU loop when Remote Loop is selected by the front panel switches.

<b>S2-4</b>	<b>RDL Type</b>
Off	Initiate a V.54 RDL loop when selected
On	Initiate a CSU loopback when selected

**Switch SW2-5 Front Panel Switches**

As the Front Panel Switches may be inadvertently toggled, or in the event that the end-user may not need to use the switches, the installer may disable the front panel switches. Set Switch S2-5 to determine whether the front-panel toggle switches are active or inactive.

<b>SW2-5</b>	<b>Option</b>
Off	Front Panel Switches Enabled
On	Front Panel Switches Disabled

**Switch SW2-6: V.54 Response Disabled (default)**

V.54 Response is a special in-band loopback facility that sends a pseudo-random pattern over the data stream. This is the only loopback that the unit can initiate. This is useful for campus applications when you need to put a remote unit in loopback. The unit responds to the V.54 loopback command, and the whole process takes only a few seconds to complete. When V.54 Loopback is disabled, the unit will not be able to send or respond to V.54 loopback commands. The duration of the loopback is limited by the loopback timeout setting.

<b>SW2-6</b>	<b>Option</b>
Off	V.54 Response Enabled
On	V.54 Response Disabled

## 4.0 INSTALLATION



The Interconnecting cables shall be acceptable for external use and shall be rated for the proper application with respect to voltage, current, anticipated temperature, flammability, and mechanical serviceability.

Once the Model 2701 is properly configured, it is ready to connect to the G.703/G.704 interface, to the serial port, and to the power source. This section describes how to make these connections.

### 4.1 CONNECTING TO THE G.703 NETWORK

The Power, G.703/G.704 and serial Line connections are located on the rear panel of the Model 2701. The following sections describe operation of these connections.

#### Connecting the 2701/D (X.21 version) Dual Coaxial Cable (75 ohm) to the G.703 Network

The Model 2701/D (X.21 version) is equipped with dual female BNCs (TX and RX) for connection to a 75 ohm dual coax G.703 network interface. If your G.703/G.704 network terminates via dual coaxial cable, use the diagram below to make the proper connections. See Figure 3.

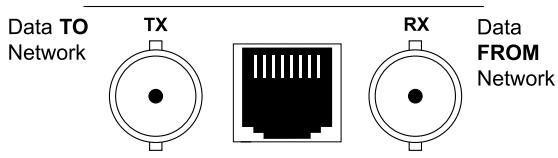

Figure 3. Rear Panel, Showing Location of Connectors.

**Note** The outer conductor of the coax cables are isolated from system earth ground.

When using the 75 Ohm interface, jumper straps JP2, JP5, JP6, and JP7 must be installed over the jumpers. The jumpers are located next to the BNC connectors. Refer to the following section to open the case. Open the case and install jumper straps for JP2, JP5, JP6, and JP7.

#### Opening the Case

Open the case by inserting a screwdriver into the slots and twist the screwdriver head slightly. The top half of the case will separate from the

lower half of the case. Take caution not to damage any of the PC board mounted components.

**Connecting the Twisted Pair (120 ohm) to the G.703 Network**

The Model 2701 is equipped with a single RJ-48C jack for connections to a 120 ohm twisted pair G.703/G.704 network interface. If your G.703/G.704 network terminates via RJ-48C, use the connection diagram (Figure 4) following the pinout and signals chart below to connect the 120 ohm G.703/G.704 network channel.

<u>NETWORK SIGNAL</u>	<u>PIN#</u>	<u>SIGNAL</u>
RX(R)	1-----	TX(R)
RX(T)	2-----	TX(T)
TX(R)	4-----	RX(R)
TX(T)	5-----	RX(T)
Shield	3-----	Shield
Shield	6-----	Shield

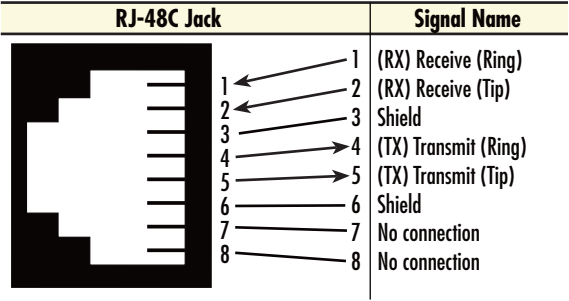

Figure 4. G.703/G.704 170 ohm Connection.

**4.2 CONNECTING THE SERIAL PORT**

The Model 2701/B, C, D supports RS-530, V.35, X.21 serial port connections. This section describes how to connect the serial ports to your terminal equipment.

**Connecting to a “DTE” Device**

The serial port on the 2701/B (RS-530 version) and 2701/C (V.35 version) is hard-wired as a DCE. Therefore these modules “want” to plug

into a DTE such as a terminal, PC or host. When making the connection to your DTE device, use a straight through cable of the shortest possible length—we recommend 6 feet or less. When purchasing or constructing an interface cable, please refer to the pin diagrams in Appendix D as a guide.

### **Connecting to a “DCE” Device**

If the Model 2701 serial interface is hard-wired as a DCE (all except the X.21 version), you must use a null modem cable when connecting to a modem, multiplexer or other DCE device. This cable should be of the shortest possible length—we recommend 6 feet or less.

### **Configuring the X.21 Interface (2701/D)**

The serial port on the X.21 interface is default wired as a DCE, but may be switched to a DTE. This is done by reversing the orientation of the DCE/DTE strap, as described below:

To reverse DCE/DTE orientation, remove the top case. Refer to section “Opening the Case” on page 14

The DCE/DTE strap is located near the DB15 connector on the top side of the board. The arrows on the top of the strap indicate the configuration of the X.21 port (for example, if the DCE arrows are pointing toward the DB-15 connector, the X.21 port is wired as a DCE). Reverse the DCE/DTE orientation by pulling the strap out of its socket, rotating it 180°, then plugging the strap back into the socket. You will see that the DCE/DTE arrows now point in the opposite directions, showing the new configuration of the X.21 port.

**Note** If the 2701/D is configured as a DTE, the clocking mode must be set for external clock.

## **4.3 POWER CONNECTION**

### **Universal AC Power (100–240 VAC)**

The Model 2701 uses a 5VDC, 2A universal input 100–240 VAC, power supply (center pin is +5V). The universal input power supply has a male IEC-320 power entry connector. This power supply connects to the Model 2701 by means of a barrel jack on the rear panel. Many international power cords are available for the universal power supply.

The Model 2701 powers up as soon as it is plugged into an AC outlet--there is no power switch.

## DC Power

The 36-60 VDC DC to DC adapter is supplied with the DC version of the Model 2701. The black and red leads plug into a DC source (nominal 48VDC) and the barrel power connector plugs into the barrel power supply jack on the 2701. (See Figure 5).



Figure 5. Connecting DC Power to the 2701 DC Power Supply.



**There are no user-serviceable parts in the power supply section of the Model 2701. Contact Patton Electronics Technical support at (301)975-1007, via our web site at <http://www.patton.com>, or by e-mail at [support@patton.com](mailto:support@patton.com), for more information.**

## 5.0 OPERATION

When the Model 2701 has been properly configured and installed, it should operate transparently. This sections describes power-up, LED status monitors, and the built-in loopback test modes.

### 5.1 POWER-UP

Before applying power to the Model 2701, please read “Power Connection” on page 16 and verify that the unit is properly connected to the appropriate power source.

### 5.2 LED STATUS MONITORS

The Model 2701 features six front panel LEDs that monitor connections on the G.703/G.704 and signaling, error and test modes. Figure 6 shows the front panel location of each LED. Descriptions of each LED follow Figure 6.

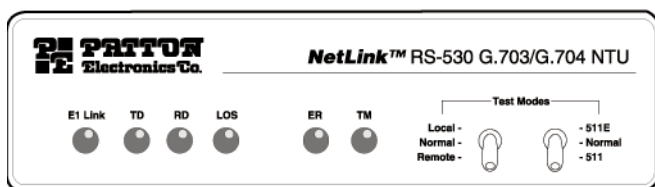

Front Panel – Plastic Case

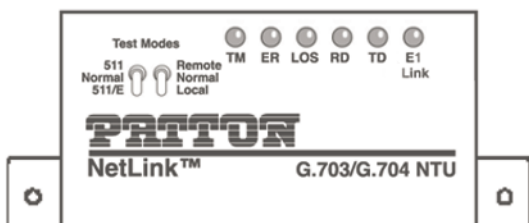

Front Panel – Metal Case

Figure 6. 2701 Front Panels

#### E1 Link

(Active Green) Solid green (On) indicates that the end to end E1 Link is up, signifying that the link is active. The E1 Link LED is Off when the link is down.

**TD & RD**

Glows yellow to indicate an idle condition of Binary "1" data on the respective terminal interface signals. Green indicates Binary "0" data.

**LOS**

The Loss of Sync LED lights when the unit loses synchronization with the incoming signal. This may happen when there is a framing mismatch or a loss of signal. In unframed mode, the LOS LED monitors the status of the transmit clock.

**ER**

The error LED indicates various error conditions, including framing bit errors, excessive zeros, controlled slips, severe errors, or bit errors (when sending V.52 test patterns). When sending a test pattern, the LED will remain lit if the unit does not receive the identical pattern. When it receives the correct pattern, the LED will turn off. If error insertion is on, the LED will blink once a second if everything is operating properly.

**TM**

(Active Yellow) Solid Yellow indicates an Active Test Mode. The unit may be placed in test mode by the local user or by the remote user.

**5.3 LOOP (V.54 & TELCO) DIAGNOSTICS**

The Model 2701 offers three V.54 loop diagnostics. Use these diagnostics to test the NTU and any communication links. These tests can be activated via the front panel switches or via signals on the Model 2701/B and C serial port interface.

**Operating Local Loopback (LL)**

The Local Loopback (LL) test checks the operation of the local Model 2701, and is performed separately on each unit. Any data sent to the local Model 2701 in this test mode will be echoed (returned) back to the user device (i.e., characters typed on the keyboard of a terminal will appear on the terminal screen).

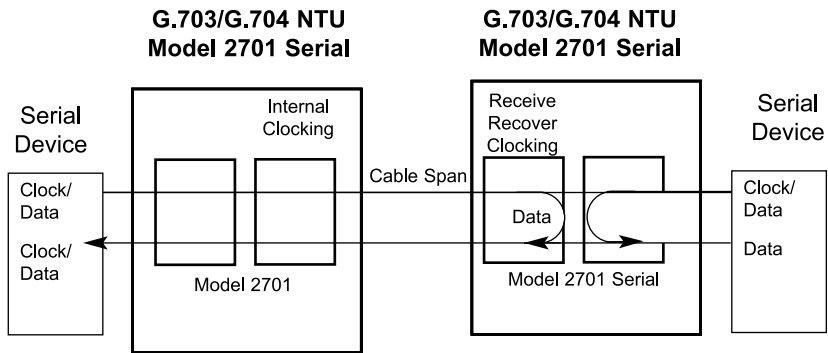

**Figure 7.** Local Loopback for a Network Termination Application

To perform a LL test, follow these steps:

1. Activate LL. This may be done in one of two ways:
  - Place the switch on the front panel in the “Local” position.
  - Activate the “LL” signal on the DTE (2701/B and 2701/C only). If you are not sure which lead is the “LL” signal, please refer to Appendix D.
2. Verify that the data terminal equipment is operating properly and can be used for a test.
3. Perform a V.52 BER (bit error rate) test as described in section “Using the V.52 (BER) Test Pattern Generator” on page 22. If the BER test equipment indicates no faults, but the data terminal indicates a fault, follow the manufacturer’s checkout procedures for the data terminal. Also, check the interface cable between the terminal and the Model 2701.

### **Operating Remote Digital Loopback (RL)**

The Remote Digital Loopback (RL) test checks the performance of both the local and remote NetLink-E1™, as well as the communication link between them. Any characters sent to the remote NetLink-E1™ in this test mode will be returned back to the originating device (i.e., characters typed on the keyboard of the local terminal will appear on the local terminal screen after having been passed to the remote NetLink-E1™ and looped back).

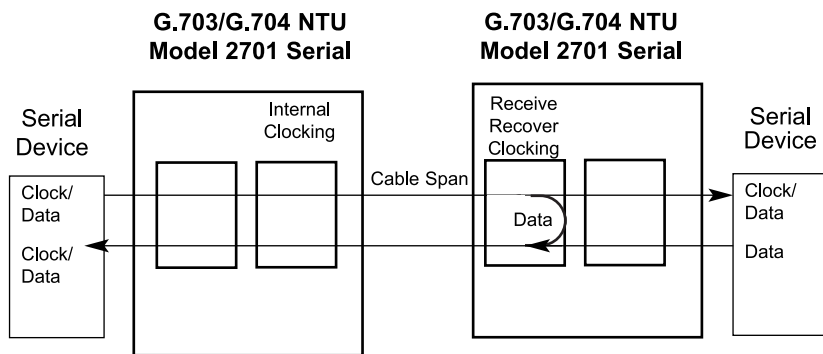

**Figure 8.** Remote Loop in a Network Extension Application

There are two Remote Loops that can be initiated from the NetLink-E1 unit: (1) V.54 Loop, and; (2) CSU Loop. The user can select the type of loop that can be initiated by Switch S2-4. When a loopback is initiated this is the type of loop that the unit uses to loop up the remote unit and which type of loop the unit will respond to.

To perform an RDL test, follow these steps:

1. Activate RDL. This may be done in two ways:
  - Activate the “RL” signal on the DTE (2701/B and 2701/C only). If you are not sure which lead is the “RL” signal, please refer to Appendix B or C, depending on the version you are using.
  - Set the front panel switch to “Remote”.
2. Perform a bit error rate test (BERT) using the internal V.52 generator (as described in section “Using the V.52 (BER) Test Pattern Generator”), or using a separate BER Tester. If the BER test indicates a fault, and the Local Line Loopback test was successful for both NetLink devices, you may have a problem with the twisted pair line connection.

### CSU Loop

Although CSU Loop is predominantly a T1 function, the NetLink-2701 responds to central office initiated loop commands. Customers can use this facility when the Central Office network switch supports CSU loops over an E1 interface.

When CSU Loop is selected, the NetLink 2701 will implement the “loop up” command when it recognizes the pattern “10000” in the data stream for a minimum of 5 seconds. The “loop down” command is implemented by the pattern “100” in the data stream for a minimum of 5 seconds.

The NetLink 2701 will respond to Universal Loopback De-activate to clear all central office loops.

### **Using the V.52 (BER) Test Pattern Generator**

To use the V.52 BER tests in conjunction with the Remote Digital Loopback tests (or with Local Line Loopback tests), follow these instructions:

1. Locate the "511/511E" toggle switch on the front panel of the 2701 and move it UP. This activates the V.52 BER test mode and transmits a "511" test pattern into the loop. If any errors are present, the local modem's red "ER" LED will illuminate.
2. If the above test indicates no errors are present, move the V.52 toggle switch DOWN, activating the "511/E" test with errors present. If the test is working properly, the local modem's red "ER" LED will blink once every second. A successful "511/E" test will confirm that the link is in place, and that the Model 2701's built-in "511" generator and detector are working properly.

**Note** The above V.52 BER tests can be used independently of the Remote Digital Loopback tests. This requires two operators: one to initiate and monitor the tests at the local Model 2701, and one to do the same at the remote Model 2701. In this case, the test pattern sent by each Model 2701 will not be looped back, but will be transmitted down the line to the other Model 2701. While one operator initiates test, the other monitors for errors.

## **APPENDIX A**

### **SPECIFICATIONS**

#### **A.1 NETWORK DATA RATE**

2.048 Mbps

#### **A.2 NETWORK CONNECTOR**

RJ-48C/Dual Coax BNC (2701/D)

#### **A.3 NOMINAL IMPEDANCE**

75/120 ohm

#### **A.4 LINE CODING**

Selectable AMI or HDB3

#### **A.5 LINE FRAMING**

G.703 (Unframed) or G.704/G.732 (Framed)

#### **A.6 CRC-4 MULTIFRAMING**

Selectable On or Off

#### **A.7 CLOCKING**

Internal, External, or Network (Receive Recover)

#### **A.8 TIME SLOT RATE**

64 kbps

#### **A.9 NETWORK DATA RATES**

64, 128, 192, 256, 320,384, 448, 512, 576, 640, 704, 768, 832, 896, 960,  
1024, 1088, 1152, 1216, 1280, 1344, 1408, 1472, 1536, 1600, 1664,  
1728, 1792, 1856, 1920, 1984, 2048 kbps

#### **A.10 DISTANCE**

Maximum 1.6 km (5,250 ft.) on 24 AWG Cable

#### **A.11 CONFIGURATION**

Two 8-Position DIP Switches

**A.12 POWER SUPPLY**

+5 VDC External power supply/100–240 VAC, 50–60Hz, 0.4A

**A.13 HUMIDITY**

Up to 90% non-condensing

**A.14 TEMPERATURE**

0 to 50°C (32 to 122°F)

**A.15 DIMENSIONS**

Plastic Case – 9.0L x 5.3W x 2.0H cm (3.5L x 2.1W x 0.78H in.)

Metal Case – 3.2L x 13.8W x 14.6H cm (1.25L x 5.43W x 5.75H in)

**APPENDIX B**  
INTERFACE PIN ASSIGNMENT

**EIA-530 Interface Pin Description  
(DB-25 Female Connector)  
(DCE Configuration)**

<b>Pin #</b>	<b>Signal</b>
1	FG (Frame Ground)
2	TD (Transmit Data)
3	RD (Receive Data)
4	RTS (Request to Send)
5	CTS (Clear to Send)
6	DSR (Data Set Ready)
7	SGND (Signal Ground)
8	CD (Carrier Detect)
9	RC/ (Receive Timing-B)
10	CD/ (Carrier Detect-B)
11	XTC/ (External Transmit Clock)
12	TC/ (Transmit Clock-B)
13	CTS/ (Clear to Send)
14	TD/ (Transmit Data-B)
15	TC (Transmit Clock-A)
16	RD (Receive Data)
17	RC (Receive Timing)
18	LLB (Local Line Loop)
19	RTS/ (Request to Send)
20	DTR (Data Terminal Ready)
21	DL (Remote Digital Loop)
22	DSR/ (Data Set Ready)
23	DTR/ (Data Terminal Ready)
24	XTC (External Transmit Clock)
25	TM (Test Mode)

**RS-530 TO RS-530  
(STRAIGHT THROUGH  
CABLE) PIN OUT**

<b>Pin #</b>	<b>Function</b>
1	Shield (A)
2	TD (A)
3	RD (A)
4	RTS (A)
5	NC
6	NC
7	Signal Ground
8	RLSD (A)
9	RX Timing DCE (B)
10	RLSD (B)
11	TX Timing DTE (B)
12	NC
13	NC
14	TD (B)
15	NC
16	RD (B)
17	RX Timing DCE (A)
18	NC
19	RTS (B)
20	NC
21	NC
22	NC
23	NC
24	TX Timing DTE (A)
25	NC

**RS-530 TO RS-530 (CROSS OVER  
CABLE) PIN OUT**

<b>Pin #</b>	<b>Function</b>	<b>Pin #</b>
1	Shield (A)	1
2	RD (A)	3
3	TD (A)	2
4	RLSD (A)	8
5	NC	5
6	NC	6
7	Signal Ground	7
8	RTS (A)	4
9	TX Timing DTE (B)	11
10	RTS (B)	19
11	RX Timing DCE (B)	17
12	NC	12
13	NC	13
14	RD (B)	16
15	NC	15
16	TD (B)	14
17	TX Timing DTE (A)	11
18	NC	18
19	RLSD (B)	10
20	NC	20
21	NC	21
22	NC	22
23	NC	23
24	RX Timing DCE (A)	17
25	NC	25

**APPENDIX C**  
INTERFACE PIN ASSIGNMENT

**V.35 Interface  
(M/34F Female Connector)  
(DCE Configuration)**

<b>Pin #</b>	<b>Signal</b>
B	SGND (Signal Ground)
C	RTS (Request to Send)
D	CTS (Clear to Send)
E	DSR (Data Set Ready)
F	CD (Carrier Detect)
H	DTR (Data Terminal Ready)
L	LLB (Local Line Loop)
M	TM (Test Mode)
N	RDL (Remote Digital Loop)
P	TD (Transmit Data)
R	RD (Receive Data)
S	TD/ (Transmit Data-B)
T	RD/ (Receive Data-B)
U	XTC (External Transmit Clock)
V	RC (Receive Timing)
W	XTC/ (External Transmit Clock)
X	RC/ (Receive Timing)
Y	TC (Transmit Clock-A)
AA	TC/ (Transmit Clock-B)

**V.35 TO V.35 (STRAIGHT  
THROUGH CABLE) PIN  
OUT**

<b>Pin</b>	<b>Function</b>
A	Frame Ground
B	Signal Ground
C	RTS
D	NC
E	DSR
F	DCD
H	DTR
K	NC
L	NC
P	TD (A)
R	RD (A)
S	TD (B)
T	RD (B)
U	SCTE (A)
V	RT (A)
W	SCTE (B)
X	RT (B)
Y	NC
AA	NC

**V.35 TO V.35 (CROSS OVER  
CABLE) PIN OUT**

<b>Pin</b>	<b>Function</b>	<b>Pin</b>
A	Frame Ground	A
B	Signal Ground	B
C	DCD	F
D	NC	D
E	DTR	H
F	RTS	C
H	DSR	E
K	NC	K
L	NC	L
P	RD (A)	R
R	TD (A)	P
S	RD (B)	T
T	TD (B)	S
U	RT (A)	V
V	SCTE (A)	U
W	RT (B)	X
X	SCTE (B)	W
Y	NC	Y
AA	NC	AA

**APPENDIX D**  
INTERFACE PIN ASSIGNMENT

**X.21 Interface**  
**(DB-15 Female Connector)**  
**(DTE /DCE Configuration)**

<b>Pin #</b>	<b>Signal</b>
1	Frame Ground
2	T (Transmit Data-A)
3	C (Control-A)
4	R (Receive Data-A)
5	I (Indication-A)
6	S (Signal Element Timing-A)
7	BT (Byte Timing-A)
8	SGND (Signal Ground)
9	T/ (Transmit Data-B)
10	C/ (Control-B)
11	R/ (Receive Data-B)
12	I/ (Indication-B)
13	S/ (Signal Element Timing-B)
14	BT/ (Byte Timing-B)

## APPENDIX E

### FACTORY REPLACEMENT PARTS AND ACCESSORIES

<b>Patton Model #</b>	<b>Description</b>
2701/B	G.703/G.704 NTU with RS-530 interface
2701/C	G.703/G.704 NTU with a V.35 interface
2701/D	G.703/G.704 NTU with an X.21 interface
2701/I	G.703/G.704 NTU w/ 10Base-T EN interface
0805US	American Power Cord
0805EUR	European Power Cord CEE 7
0805UK	United Kingdom Power Cord
0805AUS	Australia/New Zealand Power Cord
0805DEN	Denmark Power Cord
0805FR	France/Belgium Power Cord
0805IN	India Power Cord
0805IS	Israel Power Cord
0805JAP	Japan Power Cord
0805SW	Switzerland Power Cord
08055DCUI	Universal Input Power Supply
07M2701	User Manual



