

USER MANUAL

MODEL 2703RC-A
MegaLink-1™
G.703/E1 Digital Modem:
Rack Mount Card



PE PATTON
Electronics Co.



An ISO-9001
Certified Company

Part# 07M2703RC-A-A
Doc# 031122UA
Revised 2/4/99

SALES OFFICE
(301) 975-1000
TECHNICAL SUPPORT
(301) 975-1007
<http://www.patton.com>

1.0 WARRANTY INFORMATION

Patton Electronics warrants all Model 2703RC-A components to be free from defects, and will—at our option—repair or replace the product should it fail within one year from the first date of shipment.

This warranty is limited to defects in workmanship or materials, and does not cover customer damage, abuse or unauthorized modification. If this product fails or does not perform as warranted, your sole recourse shall be repair or replacement as described above. Under no condition shall Patton Electronics be liable for any damages incurred by the use of this product. These damages include, but are not limited to, the following: lost profits, lost savings and incidental or consequential damages arising from the use of or inability to use this product. Patton Electronics specifically disclaims all other warranties, expressed or implied, and the installation or use of this product shall be deemed an acceptance of these terms by the user.

1.1 RADIO AND TV INTERFERENCE

The Model 2703RC-A generates and uses radio frequency energy, and if not installed and used properly—that is, in strict accordance with the manufacturer's instructions—may cause interference to radio and television reception. The Model 2703RC-A has been tested and found to comply with the limits for a Class A computing device in accordance with the specifications in Subpart J of Part 15 of FCC rules, which are designed to provide reasonable protection from such interference in a commercial installation. However, there is no guarantee that interference will not occur in a particular installation. If the Model 2703RC-A does cause interference to radio or television reception, which can be determined by turning the power off or removing the card, the user is encouraged to try to correct the interference by one or more of the following measures: moving the computing equipment away from the receiver, re-orienting the receiving antenna and/or plugging the receiving equipment into a different AC outlet (such that the computing equipment and receiver are on different branches). In the event the user detects intermittent or continuous product malfunction due to nearby high power transmitting radio frequency equipment, the user is strongly advised to take the following steps: use only data cables with an external outer shield bonded to a metal or metalized connector; and, Configure the rear card as shown in section 3.2 of this manual.

1.2 CE NOTICE AND TELECOMMUNICATIONS APPROVALS

The CE symbol on your Patton Electronics equipment indicates that it is in compliance with the Electromagnetic Compatibility (EMC) directive and the Low Voltage Directive (LVD) of the Union European (EU). A Certificate of Compliance is available by contacting Technical Support.

The Model 1000RCM703120 and 1000RCM70375 rear cards are in compliance with the Telecommunication technical requirements CRT=12; 2.048 Mbps digital unstructured leased line (D2048U) attachment requirements for terminal equipment interface

1.3 SERVICE

All warranty and nonwarranty repairs must be returned freight prepaid and insured to Patton Electronics. All returns must have a Return Materials Authorization number on the outside of the shipping container. This number may be obtained from Patton Electronics Technical Support: **(301) 975-1007**; <http://www.patton.com>; or, support@patton.com.

NOTE: Packages received without an RMA number will not be accepted.

Patton Electronics' technical staff is also available to answer any questions that might arise concerning the installation or use of your Model 2703RC-A. Technical Service hours: **8AM to 5PM EST, Monday through Friday.**

2.0 GENERAL INFORMATION

Thank you for your purchase of this Patton Electronics product. This product has been thoroughly inspected by Patton's qualified technicians. If any questions or problems arise during installation or use of this product, please do not hesitate to contact Patton Electronics Technical Support at (301) 975-1007.

2.1 FEATURES

- Synchronous network data rate of 2.048 Mbps
- Four Selectable DTE Rates: 256, 512, 1024, and 2048 Kbps
- EIA-530 (EIA-422 Electrical), V.35, or X.21 terminal interfaces
- 120 ohm (twisted pair) or 75 ohm (coax) network terminations
- Master and Slave (network) clocking
- Built-in local loopback test
- Front panel LED indicators for power, network, master clock and test loop
- Mounts in Patton's 16-slot rack chassis and 2/4/8-slot Cluster Boxes
- Made in the U.S.A.

2.2 DESCRIPTION

The Patton *MegaLink™* Model 2703RC-A G.703/E1 rack card modem receives unstructured, synchronous 2.048 Mbps data from a G.703 network and sends it to a router, bridge, multiplexer or other device. The Model 2703RC-A is available with two interface options: 120 Ohm twisted pair to the network with EIA-530 (EIA-422) or V.35 (utilizing a 25 pin connector) to the terminal, or 75 Ohm dual coax to the network with X.21 to the terminal. An additional feature allows the EIA-530 terminal interface to be adapted to X.21 using a special DTE cable (available from Patton).

The Model 2703RC-A is designed to mount in Patton's 2U high, 16-slot rack chassis or 2/4/8-slot Cluster Boxes. These have a switchable 120/240 VAC power supply (optional 48 VDC) and mount cards in a mid-plane architecture: front "function" cards and rear "interface" cards can be hot-swapped independently, providing great flexibility. The Model 2703RC-A supports Internal (master) and Network (slave) clocking. Loopback test is built-in, and front panel LEDs monitor power, network, master clock and test loop.

3.0 CONFIGURATION

Two cards make up a single Model 2703RC-A G.703 Converter - a front function card and a rear interface card. Each may require configuration depending upon the product application. This section describes the location and orientation of the Model 2703RC-A's configuration switches and jumpers, and provides descriptions for all settings.

3.1 FRONT CARD CONFIGURATION

The Model 2703RC-A front card has a single bank of eight DIP switches located on the top of the printed circuit board. Figure 1, below, shows the position of the switches on the board.

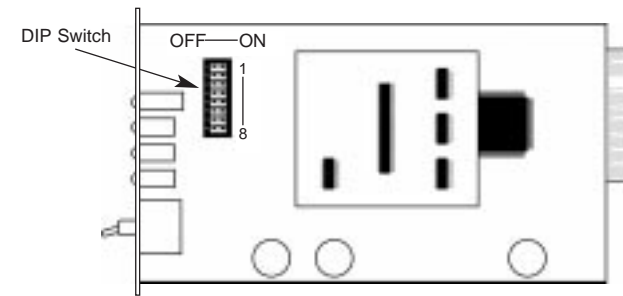

Figure 1. Model 2703RC-A board, showing switch locations

Changing the DIP Switch Settings

Figure 2 shows the orientation of the DIP switches with respect to the "ON" and "OFF" positions.

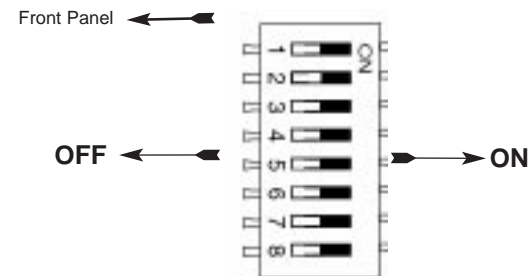

Figure 2. Close up of the configuration switches
NOTE: The OFF position is oriented toward the front of the Model 2703RC-A

3.1 DIP Switches S1 - S8

The configuration switches on S1 - S8 may be used to set data inversion, the DTE bit rate, and clocking modes. Default settings of S1 through S8 are shown in the table below. Descriptions of each switch follow the table.

SWITCH SUMMARY TABLE		
Position	Function	Factory Default
S1	Data Inversion	Off Non-Inverted
S2	Rate Adaptation (DTE Rate)	Off } 2.048 Mbps Off }
S3	Rate Adaptation (DTE Rate)	
S4	<i>Reserved</i>	Off
S5		Off
S6	Clock Mode	Off Network
S7	<i>Reserved</i>	Off
S8		Off

Switch S1: Data Inversion

Set Switch S1 to determine whether or not the data stream from the local DTE is inverted within the Model 2703RC-A before being passed to the G.703 network. You may need to invert the data stream when you use the Model 2703RC-A with an imbedded G.703 device that inverts the data on the remote end. Data inversion is typically not necessary.

<u>S1-1</u>	<u>Setting</u>
On	Data inverted
Off	Data not inverted

NOTE: The PCM data stream must be inverted if this Model 2703RC-A is to be connected to a standalone Model 2703 Firmware Revision B (or older) unit at 256, 512, and 1024 kbps. The firmware version of the standalone 2703 is printed on the bottom side of the unit.

Switches S2 and S3: Rate Adaptation (DTE Rate)

Set Switches S2 and S3 together to allow the Model 2703RC-A to adapt to terminal devices that run at data rates less than 2.048 Mbps (The network rate remains 2.048 Mbps regardless of the terminal rate adaptation setting). The setting you select must match the data rate of your terminal device.

<u>S2</u>	<u>S3</u>	<u>Setting</u>
Off	Off	2.048 Mbps
On	Off	1.024 Mbps
Off	On	512 Kbps
On	On	256 Kbps

Switches S4 and S5: *Reserved for Future Use*

Switches S4 and S5 are reserved for future use and must remain in the Off position.

Switch S6: Internal/Network Clock

Set Switch S6 to allow the Model 2703RC-A to provide an internal clock, or recover the clock from the received G.703 input signal.

<u>S6</u>	<u>Setting</u>
On	Model 2703RC-A clock is internal
Off	Model 2703RC-A clock is recovered from the network

NOTE: The 2703RC-A does not support an external (DTE Source) clock option.

Switches S7 and S8: *Reserved for Future Use*

Switches S7 and S8 are reserved for future use and must remain in the Off position.

3.1.1 Interface Driver Board

The Model 2703RC-A Series features changeable Interface Driver Boards that allow a wide range of DTE interface connections. Supported interfaces are V.35, EIA-530, and X.21. The Interface Driver Board plugs onto a 40 pin header (2 rows of 20 pins) on the top side of the 2703RC-A PC board (See Figure 3, below).

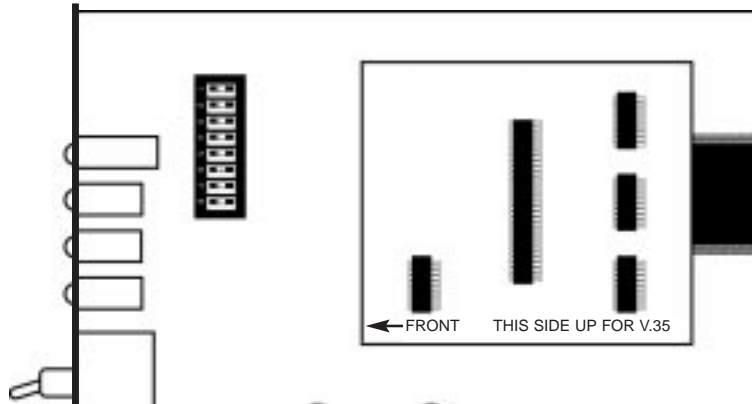

Figure 3. Closeup of Model 2703RC-A Interface Driver Board

Your 2703RC-A comes with an Interface Driver Board already mounted on the board. If you wish to change the electrical interface of the 2703RC-A, you must change the Interface Driver Board (See Appendix B for Model Numbers).

Follow the instructions below to change the Interface Driver Board:

1. With the 2703RC-A pulled out of the rack or clusterbox chassis, locate the driver board on the top of the 2703RC-A front card.
2. Lift the interface board gently off of the PC board.
3. Locate the correct interface on the bottom of the driver board. For example, V.35 interface board is marked **“THIS SIDE UP FOR V.35”** on one side of the board other side .
4. Plug the interface board into the 20 pin header socket with the appropriate interface pointed UP and with the arrow pointing toward the front panel of the Model 2703RC-A PC board.
5. Push the Interface Driver Board gently onto the socket and re-install into the rack or cluster system.

3.2 REAR CARD CONFIGURATION

The Model 2703RC-A has two rear interface card options:

1. **Model 1000RCM703120** - 120 Ohm (modular) network and female (DB-25) terminal (Supports V.35, EIA-530, and X.21).
2. **Model 1000RCM70375** - 75 ohm (dual BNC) network and female (DB-15) terminal (Supports X.21 Only).

Please refer to the instructions below to configure the rear cards.

3.2.1 CONFIGURING THE 1000RCM703120 REAR CARD

The Model 1000RCM120 DB25/RJ45 Ohm rear card has five configuration jumpers (LK1 - LK5). Figure 4 (below) shows the locations of the jumpers on the 120 Ohm rear card.

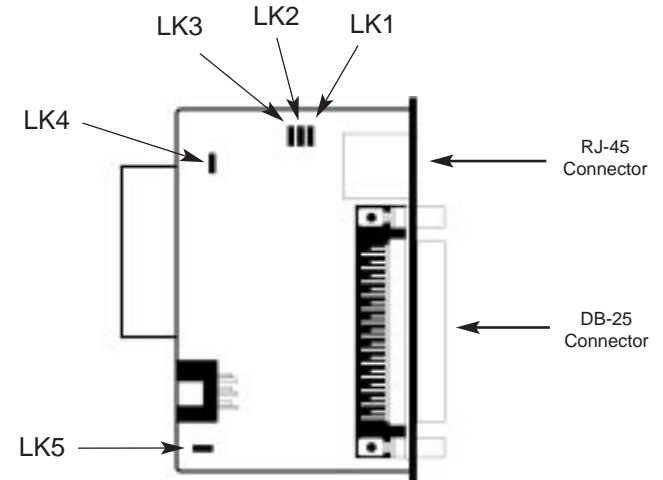

Figure 4. Jumper Locations for the Model 1000RCM703120 Rear Card

The table below shows the factory default jumper settings for the Model 1000RCM703120 DB25/RJ-45 rear card. Following the table is a description of each jumper's function and possible settings. When configuring the jumpers, take care not to lose the individual straps.

120 OHM REAR CARD JUMPERS		
Jumper	Function	Factory Default
LK1	RX Pin 2 to GND	Strap Off
LK2	RX Shield (Pin 3) to GND	Strap Off
LK3	TX Pin 4 to GND	Strap Off
LK4	Clock Synchronization	Strap Off
LK5	(DTE) SGND to FGND	Strap On

LK1: (Receive Pair) Pin 2-to-Ground Connection

This setting determines whether or not pin 2 of the receive pair is sent to earth ground. This connection should not be made in most cases.

LK1	Setting
Strap On	Pin 2-to-GND Connection Made
Strap Off	Pin 2-to-GND Connection Broken

LK2: Receive Shield (Pin 3)-to-Ground Connection

This setting determines whether or not the RX shield (pin 3) is connected to earth ground. This connection may help EMC performance in some cases.

LK2	Setting
Strap On	Pin 3-to-GND Connection Made
Strap Off	Pin 3-to-GND Connection Broken

LK3: (Transmit Pair) Pin 4-to-Ground Connection

This setting determines whether or not pin 4 of the transmit pair is sent to earth ground. This connection should not be made in most cases.

LK3	Setting
Strap On	Pin 4-to-GND Connection Made
Strap Off	Pin 4-to-GND Connection Broken

LK4: Clock Synchronization (EIA-530/V.35 vs. X.21)

This setting determines whether clocks are common or separate. Separate (non-synchronized) clocks are used for the EIA-530/V.35 terminal interface. Common (synchronized) clocks are used for the X.21 terminal interface. If clocks are synchronized, a DB-25 to DB-15 adapter cable should be used between the Model 2703RC-A and the X.21 terminal device (see **Appendix B** and **Appendix C** for details).

LK4	Setting
Strap On	Clocks Synchronized (X.21)
Strap Off	Clocks not Synchronized (EIA-530 and V.35)

LK5: DTE Signal Ground-to-Frame Ground (with Resistor)

This setting determines whether or not the DTE signal ground (DB-25 pin 7) is connected to frame ground (pin 1) by way of a 100 ohm resistor. This connection is recommended in the EIA-530 specification as a current limiter for ground fault events.

LK5	Setting
Strap On	SGND-to-FGND Connection Made
Strap Off	SGND-to-FGND Connection Broken

3.2.2 CONFIGURING THE MODEL 1000RCM70375 REAR CARD

The Model 1000RCM70375 DB15/Coax Ohm rear card has two configuration jumpers (LK1 & LK2). Figure 5 (below) shows the locations of the jumpers on the 75 Ohm rear card.

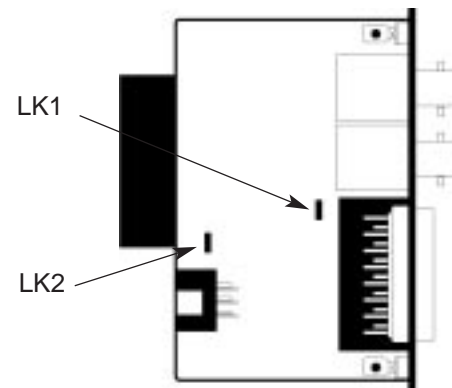

Figure 5. Jumper Locations for the Model 1000RCM70375 Rear Card

4.0 INSTALLATION

The table below shows the factory default jumper settings for the 75 ohm rear card. Following the table is a description of each jumper's function and possible settings. When configuring the jumpers, take care not to lose the individual straps.

75 OHM REAR CARD JUMPERS		
Jumper	Function	Factory Default
LK1	RX Shield to GND	Strap Off
LK2	(DTE) SGND to FGND	Strap On

LK1: Receive Shield-to-Ground Connection

This setting determines whether or not the RX shield is connected to earth ground. This connection may help EMC performance in some cases.

<u>LK1</u>	<u>Setting</u>
Strap On	RX Shield-to-GND Connection Made
Strap Off	RX Shield-to-GND Connection Broken

LK2: DTE Signal Ground-to-Frame Ground (with Resistor)

This setting determines whether or not the DTE signal ground (DB-15 pin 8) is connected to frame ground (pin 1) by way of a 100 ohm resistor. This connection is recommended as a current limiter for ground fault events.

<u>LK2</u>	<u>Setting</u>
Strap On	SGND-to-FGND Connection Made
Strap Off	SGND-to-FGND Connection Broken

This section describes the functions of the Model 1000R16 rack chassis, tells how to install front and rear Model 2703RC-A cards into the chassis, and provides diagrams for wiring the interface connections correctly.

4.1 THE MODEL 1000R16 RACK CHASSIS

The Model 1000R16 Rack Chassis (Figure 6, below) has sixteen device card slots, plus its own power supply. Measuring only 3.5" high, the Model 1000R16 is designed to occupy only 2U in a 19" rack. Sturdy front handles allow the Model 1000R16 to be extracted and transported conveniently.



Figure 6. Model 1000R16 Rack Chassis with power supply

4.1.1 THE RACK POWER SUPPLY

The power supply included in the Model 1000R16 rack uses the same mid-plane architecture as the modem cards. The front card of the power supply slides in from the front, and the rear card slides in from the rear. They plug into one another in the middle of the rack. The front card is then secured by thumb screws and the rear card by conventional metal screws.

WARNING! There are no user-serviceable parts in the power supply section of the Model 2703RC-A. Voltage setting changes and fuse replacement should only be performed by qualified service personnel. Contact Patton Electronics Technical support at (301)975-1007 for more information.

Switching the Power Supply On and Off

The power supply on/off switch is located on the front panel. When plugged in and switched on, a red front panel LED will glow. Since the Model 1000R16 is a “hot swappable” rack, *it is not necessary for any cards to be installed before switching on the power supply.* The power supply may be switched off at any time without harming the installed cards.

NOTE: Please refer to the Model 1000RP Series User Manual *AC and DC Rack Mount Power Supplies* for fuse and power card replacement information.

4.2 INSTALLING THE MODEL 2703RC-A INTO THE CHASSIS

The Model 2703RC-A is comprised of a front card and a rear card. The two cards meet inside the rack chassis and plug into each other by way of mating 50 pin card edge connectors. Use the following steps as a guideline for installing each Model 2703RC-A into the rack chassis:

1. Slide the rear card into the back of the chassis along the metal rails provided.
2. Secure the rear card using the metal screws provided.
3. Slide the card into the front of the chassis. It should meet the rear card when it’s almost all the way into the chassis.
4. Push the front card *gently* into the card-edge receptacle of the rear card. It should “click” into place.
5. Secure the front card using the thumb screws.

NOTE: Since the Model 1000R16 chassis allows “hot swapping” of cards, it is *not necessary to power down* the rack when you install or remove a Model 2703RC-A.

4.3 CONNECTION TO THE G.703 NETWORK

The Model 2703RC-A supports 2.048 Mbps communication over an unstructured G.703 network. Both 120 ohm and 75 ohm interface cards are available (see Figure 7, below).

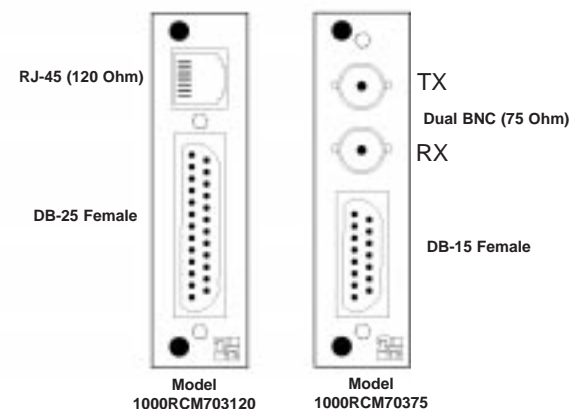

Figure 7. Rear interface card options for the Model 2703RC

4.3.1 TWISTED PAIR (120 OHM) CONNECTION

The Model 2703RC-A DB25/R45 rear card (Model 1000RCM703120) is equipped with a single RJ-45 jack for connection to a 120 ohm twisted pair G.703 network interface. The pinout of this jack is as follows:

<u>RJ-45 Pins</u>	<u>SIGNAL</u>
1 & 2	Receive pair (from network)
3	Shield reference point
4 & 5	Transmit pair (to network)
6	Shield reference point
7	Not used
8	Not used

Notice! Any modular twisted pair cable connected to the rear card must be shielded cable, and the outer shield must be properly terminated to a shielded modular plug on both ends of the cable.

4.3.2 DUAL COAX BNC (75 OHM) CONNECTION

The Model 2703RC-A DB15/Coax rear card is equipped with dual female BNCs (TX and RX) for connection to a 75 ohm dual coax G.703 network interface. The outer conductor of the coax cables is isolated from system earth ground.

Notice! Any coaxial cable connected to the dual coax rear card must incorporate an outer shield that has no less than 90% coverage.

4.4 CONNECTION TO THE TERMINAL DEVICE

The Model 2703RC-A rear cards are wired as Data Circuit-Terminating Equipment (DCE) and are designed to connect directly to Data Terminal Equipment (DTE).

Notice! Any terminal cable connected to the Model 2703RC must be shielded cable, and the outer shield must be 360 degree bonded—at both ends—to a metal or metalized backshell.

4.4.1 EIA-530 (RS422) and V.35 TERMINAL CONNECTION

The DB25 connector of the Model 1000RCM703120 rear card is configured as DCE (see the wiring diagram in **Appendix C**). To connect to a V.35 or EIA-530 DTE device, use a *straight-through* DB-25 cable. NOTE: The 120 ohm rear card must be set for non-synchronized clocking (See **Section 3.2.1**) in order to support the EIA-530 or V.35 interfaces.

4.4.2 X.21 TERMINAL CONNECTION

The DB15 connector of the Model 2703RC-A is equipped with a female DB-15 connector and is, wired according to the ITU/CCITT X.21 standard (see the wiring diagram in **Appendix C**). To connect to an X.21 terminal (DTE), use a *straight-through* DB-15 cable.

Note: The 120 ohm rear card can also be used with X.21 terminal devices. To do this, the card must be set for synchronized clocking (See **Section 3.2.1**), a DB-25 to DB-15 adapter cable must be used. See **Appendix B** for the adapter cable part numbers. Or, you may construct your own cable using the diagrams in **Appendix C**.

5.0 OPERATION

Once you have configured each Model 2703RC-A and connected the cables, you are ready to operate the units. Section 5.0 describes the power-up procedure, LED status indicators and the built-in loopback test modes.

5.1 POWER-UP

There is no power switch on the Model 2703RC-A: Power is automatically applied to the Model 2703RC-A when its card-edge connector makes contact with the chassis' mid-plane socket, and when the chassis' power supply is turned on. *Note: The Model 2703RC-A is a "hot swappable" card—it will not be damaged by plugging it in or removing it while the rack is powered up.*

5.2 LED STATUS MONITORS

The Model 2703RC-A features four front panel LEDs that monitor power, network connection, master clock and loopback. Figure 8 (below) shows the front panel location of each LED. Following Figure 7 is a description of each LED's function.

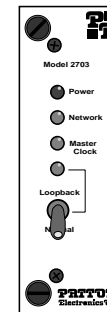

Figure 8. Model 2703RC-A front panel, showing LED indicators.

Power	Glows green when the Model 2703RC-A receives operational power.
Network	Glows green when the Model 2703RC-A is receiving correctly encoded data from the line interface equipment.
Master Clock	Glows green when the Model 2703RC-A is configured as the master clock unit.
Loopback	Glows green when the Model 2703RC-A is in loopback mode.

APPENDIX A

5.3 LOOPBACK TEST (LAL)

The Model 2703RC-A is equipped with a Local Analog Loopback (LAL) mode to assist in evaluating the operation of the local Model 2703RC-A. Any data sent to the local Model 2703RC-A in this test mode will be echoed (returned) back to the user device. For example, characters typed on the keyboard of a terminal will appear on the terminal screen.

To perform a LAL test, follow these steps:

- A. Activate LAL by moving the front panel toggle switch UP and holding it in the "Loopback" mode. The "Loop" LED should glow. Once LAL is activated, the Model 2703RC-A transmit output is connected to its own receiver. (**Note:** The front panel switch is spring loaded, so it will return to "Normal" operating mode when pressure is released.)
- B. Verify that the data terminal equipment is operating properly and can be used for a test. If a fault is indicated, call a technician or replace the unit.
- C. Perform a BER (bit error rate) test on each unit. If the BER test equipment indicates no faults, but the data terminal indicates a fault, follow the manufacturer's checkout procedures for the data terminal. Also, check the interface cable between the terminal and the Model 2703RC-A.

MODEL 2703RC-A SPECIFICATIONS

Network Interface:	G.703
Network Rate:	2.048 Mbps
Network Connectors:	Two BNC (75 Ohm) or one modular RJ-45 connector (120 Ohm)
Terminal Interface:	EIA-530 (RS-422), V.35, or X.21 on DB-25 female or ITU/CCITT X.21 on DB-15 female
Internal Interface:	Connection to Model 1000R16 rack chassis via 50 pin male card edge
Terminal Rate:	256, 512, 1024, 2048 kbps
Diagnostics:	Loopback Test
Indicators:	LEDs for power, network, master clock and loopback test
Clocking:	Master Internal , Slave (Recovered from the G.703 Network)
Receiver Sensitivity:	-10 dB (0dB = 2.4V Peak)
Temperature Range:	0-60°C (32-140°F)
Altitude:	0-15,000 feet
Humidity:	5 to 95% noncondensing
Front Card Dimensions:	0.95"W x 3.1"H x 5.4"L
Rear Card Dimensions:	0.95"W x 3.1"H x 2.8"L

APPENDIX B

MODEL 2703RC-A FACTORY REPLACEMENT PARTS

The Patton Model 2703RC-A rack system features interchangeable rear cards, power cords/fuses for international various operating environments and other user-replaceable parts. Model numbers, descriptions and prices for these parts are listed below:

<u>Patton Model #</u>	<u>Description</u>
1000RPEM.....	120/240V Rear Power Entry Module
1000RPSM.....	120/240V Front Power Supply Module
1000RPEM-DC	DC Rear Power Entry Module
1000RPSM-48A	48V Front Power Supply Module
1000RPEM-V	120/240V CE Compliant Rear Power Entry Module
1000RPSM-V	120/240V CE Compliant Front Power Supply Module
1180RC DB	V.35 Interface Driver Board
IM1RC/B.....	EIA-530 Interface Driver Board
IM1RC/D	EIA-530 Interface Driver Board
1000RCM703120.....	EIA-530/RJ45 120 Ohm Rear Card
1000RCM70375.....	X.21/Dual Coaxial 75 Ohm Rear Card
0805US	American Power Cord
0805EUR.....	European Power Cord CEE 7
0805UK	United Kingdom Power Cord
0805AUS.....	Australia/New Zealand Power Cord
0805DEN.....	Denmark Power Cord
0805FR	France/Belgium Power Cord
0805IN.....	India Power Cord
0805IS.....	Israel Power Cord
0805JAP.....	Japan Power Cord
0805SW	Switzerland Power Cord
0516FPB1	Single Width Blank Front Panel
0516FPB4	4-Wide Blank Front Panel
0516RPB1	Single Width Blank Rear Panel
0516RPB4.....	4-Wide Blank Rear Panel
056S1	Set of 16 #4 pan head screws/washers
10-25M/15F-1.....	Cable, 6ft, DB-25 male to DB-15 female
10-25M/35F-1.....	Cable, 6ft, DB-25 male to M/34 female
10-25M/35M-1.....	Cable, 6ft, DB-25 male to M/34 male

APPENDIX C

MODEL 2703RC-A-A INTERFACE STANDARDS

**X.21 Interface
DB-15 Female Connector**

DB15 Female		
<u>Pin</u>	<u>Signal</u>	<u>Source</u>
1	Frame Ground	-
2	Transmit (a)	DTE
3	Control (a)	DTE
4	Receive (a)	DCE
5	Indication (a)	DCE
6	Signal Timing (a)	DCE
7	-	-
8	Signal Ground	-
9	Transmit (b)	DTE
10	Control (b)	DTE
11	Receive (b)	DCE
12	Indication (b)	DCE
13	System Clock (b)	DCE
14	-	-
15	-	-

APPENDIX C

MODEL 2703RC-A-A INTERFACE STANDARDS

EIA-530 & V.35 Interface DB25 Female Connector

<u>Pin</u>	<u>Signal</u>	<u>Source</u>
1	FG (Frame Ground)	-
2	TD(Transmit Data-A)	DTE
3	RD (Receive Data-A)	DCE
4	RTS (Request to Send-A)	DTE
5	CTS (Clear to Send-A)	DCE
6	DSR (Data Set Ready-A)	DCE
7	SGND (Signal Ground)	-
8	CD (Carrier Detect-A)	DCE
9	RC/ (Receiver Clock-B)	DCE
10	CD/ (Carrier Detect-B)	DCE
11	-	
12	TC/ (Transmit Clock-B)	DCE
13	CTS/ (Clear to Send-B)	DCE
14	TD/ (Transmit Data-B)	DTE
15	TC (Transmit Clock-A)	DCE
16	RD (Receive Data-B)	DCE
17	RC (Receiver Clock-A)	DCE
18	-	
19	RTS/ (Request to Send-B)	DTE
20	DTR (Data Terminal Ready-A)	DTE
21	-	
22	DSR/ (Data Set Ready-B)	DCE
23	DTR/ (Data Terminal Ready-B)	DTE
24	-	
25	-	