

# DialFire 2977 Series **Remote Access Server**

---

## *User Manual*

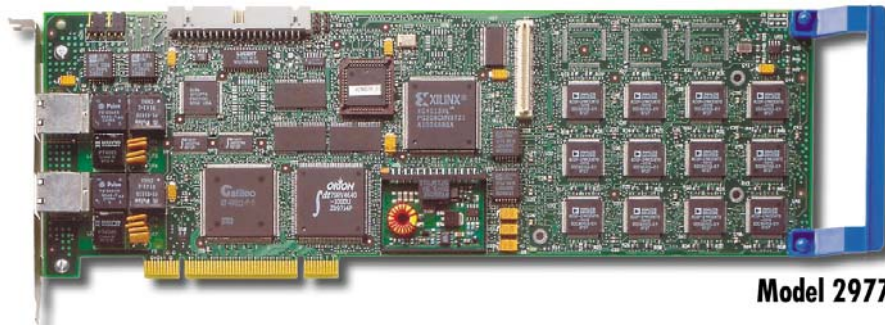

Sales Office: **+1 (301) 975-1000**  
Technical Support: **+1 (301) 975-1007**  
E-mail: **support@patton.com**  
URL: **www.patton.com**

**Patton Electronics Company, Inc.**

7622 Rickenbacker Drive  
Gaithersburg, MD 20879 USA  
tel: +1 (301) 975-1000  
fax: +1 (301) 869-9293  
support: +1 (301) 975-1007  
web: [www.patton.com](http://www.patton.com)  
e-mail: [support@patton.com](mailto:support@patton.com)

Copyright © 2012, Patton Electronics Company. All rights reserved.

The information in this document is subject to change without notice. Patton Electronics assumes no liability for errors that may appear in this document.

Any software described in this document is furnished under license and may be used or copied only in accordance with the terms of such license.

# Contents

<b>Compliance Information</b> .....	6
Radio and TV Interference .....	6
Industry Canada Notice.....	6
FCC Information .....	6
FCC Part 68 Compliance Statement .....	8
CE Notice .....	8
<b>About this user guide</b> .....	9
Audience .....	9
Structure.....	9
Precautions .....	10
Typographical conventions used in this document.....	10
General conventions .....	10
Mouse conventions .....	11
<b>1 DialFire Model 2977 RAS Adapters</b> .....	<b>12</b>
Introduction .....	13
Model 2977 DialFire RAS overview .....	13
Model 2977/B4 DialFire BRI RAS .....	14
Model 2977 DialFire T1/E1 RAS .....	14
Supported Operating Systems.....	15
<b>2 Preparation</b> .....	<b>16</b>
Completing a configuration worksheet .....	17
DialFire Basic BRI Configuration Worksheet.....	18
DialFire PTE Configuration Worksheet, Channelized T1, Long Haul (External T1).....	19
DialFire Channelized T1, Short-Haul Configuration Worksheet .....	20
DialFire PTE ISDN E1 (Euro ISDN) Configuration Worksheet .....	21
DialFire PTE ISDN T1 (PRI), Long-Haul (External T1) Configuration Worksheet.....	22
DialFire ISDN T1 (PRI), Short-Haul Configuration Worksheet.....	24
<b>3 Installing the Model 2977 adapter</b> .....	<b>26</b>
Introduction .....	27
Model 2977 B4 ST adapter installation .....	27
Determining your line termination requirements .....	27
Installing the DialFire RAS B4ST Adapter .....	28
Model 2977 B4 U adapter installation.....	29
Model 2977 PE1 PE2 adapter installation .....	31
Model 2977 PT1 PT2 adapter installation .....	32
Model 2977 daughter board installation.....	33
Parts List .....	33
Installation .....	33
<b>4 Driver installation and configuration</b> .....	<b>36</b>

Introduction .....38

Driver installation for the Windows 2000 operating system .....38

    Supported Products .....38

    Requirements .....38

    Procedure .....38

    Installing the Driver .....38

        Procedure .....39

    Upgrading the Driver .....39

        Procedure .....39

Driver installation for the Windows XP operating system .....40

    Additional Notes .....41

    Configuring Incoming Dial-up Networking Connections .....41

        Procedure .....41

    Configuring Outgoing Dial-up Networking Connections .....41

        Procedure .....42

    Changing Adapter Properties .....42

        Procedure .....42

    Changing Phone and Modem Options .....42

        Procedure .....42

    Uninstalling the Driver .....43

        Procedure .....43

    Using the Windows Troubleshooter .....43

        Procedure .....43

Driver installation for the Microsoft Windows NT operating system.....44

    Installing the downloaded driver .....44

        Procedure .....44

    Installing the MS Loopback Adapter .....44

        Procedure .....44

    Configuring the Adapter: First Time .....45

        Procedure .....45

    Changing the Adapter Configuration .....45

        Procedure .....45

    Configuring RAS Ports .....45

        Procedure .....45

    Configuring RAS Dial-in Permissions .....46

        Procedure .....47

    Configuring Dial-up Networking Connections .....47

        Procedure .....47

    Configuring Modems on COM Ports .....47

        Procedure .....47

    Uninstalling the Driver .....47

        Procedure .....47

    Changing Serial Port Names .....48

        Procedure .....48

<b>5</b>	<b>Using the Viewer .....</b>	<b>49</b>
	About Patton View .....	50
	Starting Patton View .....	50
<b>6</b>	<b>Operation and shutdown.....</b>	<b>51</b>
	Activating the Model 2977 .....	52
	De-activating the Model 2977 .....	52
<b>7</b>	<b>Contacting Patton for assistance .....</b>	<b>53</b>
	Introduction .....	54
	Contact information.....	54
	Warranty Service and Returned Merchandise Authorizations (RMAs).....	54
	Warranty coverage .....	54
	Out-of-warranty service .....	54
	Returns for credit .....	54
	Return for credit policy .....	55
	RMA numbers .....	55
	Shipping instructions .....	55
<b>A</b>	<b>Software License Agreements .....</b>	<b>56</b>
	Agreement for using the DialFire driver software with the Microsoft Windows 2000 operating system .....	57
	Agreement for using the DialFire driver software with the Microsoft Windows NT operating system .....	58

# Compliance Information

## Radio and TV Interference

---

The Model 2977 generates and uses radio frequency energy, and if not installed and used properly—that is, in strict accordance with the manufacturer's instructions—may cause interference to radio and television reception. The Model 2977 has been tested and found to comply with the limits for a Class A computing device in accordance with the specifications in Subpart B of Part 15 of FCC rules, which are designed to provide reasonable protection from such interference in a commercial installation. However, there is no guarantee that interference will not occur in a particular installation. If the Model 2977 causes interference to radio or television reception, which can be determined by disconnecting the cables, try to correct the interference by one or more of the following measures: moving the computing equipment away from the receiver, re-orienting the receiving antenna, and/or plugging the receiving equipment into a different AC outlet (such that the computing equipment and receiver are on different branches).

## Industry Canada Notice

---

The Canadian Department of Communications label identifies certified equipment. This certification means that the equipment meets certain telecommunications network protective, operational and safety requirements. The Department does not guarantee the equipment will operate to the user's satisfaction. Before installing this equipment, users should ensure that it is permissible to be connected to the facilities of the local telecommunications company. The equipment must also be installed using an acceptable method of connection. In some cases, the company's inside wiring associated with a single line individual service may be extended by means of a certified connector assembly (telephone extension cord). The customer should be aware that compliance with the above condition may not prevent degradation of service in some situations. Repairs to some certified equipment should be made by an authorized maintenance facility designated by the supplier. Any repairs or alterations made by the user to this equipment, or equipment malfunctions, may give the telecommunications company cause to request the user to disconnect the equipment. Users should ensure for their own protection that the ground connections of the power utility, telephone lines and internal metallic water pipe system, are connected together. This protection may be particularly important in rural areas.



Users should not attempt to establish or modify ground connections themselves, instead they should contact the appropriate electric inspection authority or electrician.

## FCC Information

---

The Model 2977 has been tested with the specifications in Part 68 of the FCC rules. Your telephone company may make changes in its facilities, equipment, operations or procedures that could affect the proper operation of the Model 2977. If this happens, the telephone company should give you advance notice to prevent the interruption of your service. The telephone company may decide to temporarily discontinue your service if they believe your Model 2977 may cause harm to the telephone network. Whenever possible, they will contact

you in advance. If you elect to do so, you have the right to file a complaint with the FCC. If you have any trouble operating the Model 2977, please contact Patton Electronics Technical Support at +1 301-975-1000. The telephone company may ask you to disconnect the equipment from the telephone network until the problem has been corrected or until you are certain that the Model 2977 is not malfunctioning. In accordance with FCC rules and regulation CFR 47 68.218(b)(6), you must notify the telephone company prior to disconnection. The following information may be required when applying to your local telephone company for leased line facilities. The Universal Service Order Code (USOC) is RJ49C. The Facility Interface Codes (FIC) are shown in table 1 (for the DialFire B4/ST), table 2 (for the DialFire B4/U), and table 3 (for the DialFire 24/48 Dual-T1). The Service Order Code (SOC) is 6.0P.

Table 1. DialFire B4/ST RAS

<b>Service</b>	<b>Facility Interface Code</b>	<b>Service Code</b>	<b>Network Connection</b>
1.544 Mbps SF format without line power	02IS5	6.0P	RJ-49C
1.544 Mbps SF and B8ZS without line power	02IS5	6.0P	RJ-49C
1.544 Mbps ANSI ESF without line power	02IS5	6.0P	RJ-49C
1.544 Mbps ANSI ESF and B8ZS without line power	02IS5	6.0P	RJ-49C

Table 2. DialFire B4/U RAS

<b>Service</b>	<b>Facility Interface Code</b>	<b>Service Code</b>	<b>Network Connection</b>
1.544 Mbps SF format without line power	02IS5	6.0P	RJ-49C
1.544 Mbps SF and B8ZS without line power	02IS5	6.0P	RJ-49C
1.544 Mbps ANSI ESF without line power	02IS5	6.0P	RJ-49C
1.544 Mbps ANSI ESF and B8ZS without line power	02IS5	6.0P	RJ-49C

Table 3. DialFire 24/48 Dual T1 RAS

<b>Service</b>	<b>Facility Interface Code</b>	<b>Service Code</b>	<b>Network Connection</b>
1.544 Mbps SF format without line power	02IS5	6.0P	RJ-49C
1.544 Mbps SF and B8ZS without line power	02IS5	6.0P	RJ-49C
1.544 Mbps ANSI ESF without line power	02IS5	6.0P	RJ-49C
1.544 Mbps ANSI ESF and B8ZS without line power	02IS5	6.0P	RJ-49C

## FCC Part 68 Compliance Statement

---

This equipment complies with Part 68 of FCC Rules. Please note the following:

1. You are required to request service from the telephone company before you connect the RAS to a network. When you request T1 Service, you must provide the telephone company with the Facility Interface Code. Provide the telephone company with the appropriate FIC codes from Table 1 on page 7 for the DialFire B4/ST, Table 2 on page 7 for the DialFire B4/U, or Table 3 on page 7 for the DialFire 24/48 Dual-T1. The telephone company will select the code it has available. The Service Order Code(s) (SOC): 6.0P. The required Universal Service Order Code (USOC) jack: RJ49C. The make, model number, and FCC Registration number of the RAS.
2. Your telephone company may make changes to its facilities, equipment, operations, or procedures that could affect the proper functioning of your equipment. The telephone company will notify you in advance of such changes to give you an opportunity to maintain uninterrupted telephone service.
3. If your RAS causes harm to the telephone network, the telephone company may temporarily discontinue your service. If possible, they will notify you in advance, but if advance notice is not practical, you will be notified as soon as possible and will be informed of your right to file a complaint with the FCC.
4. If you experience trouble with the RAS, please contact Patton Electronics, Co. for service or repairs. Repairs should be performed only by Patton Electronics Co.
5. You are required to notify the telephone company when you disconnect the RAS from the network.

## CE Notice

---

The CE symbol on your Patton Electronics equipment indicates that it is in compliance with the Electromagnetic Compatibility (EMC) directive and the Low Voltage Directive (LVD) of the European Union (EU). A Certificate of Compliance is available by contacting Technical Support.



# About this user guide

This guide describes installing and configuring a Patton Electronics Model 2977 Remote Access Server (RAS). It provides:

- An introduction to your Patton product, how to install, configure and use the Patton product and, if applicable, how to troubleshoot should you encounter a problem
- Configuration examples, where appropriate
- Administration procedures, where applicable

## Audience

---

This guide is intended for the person responsible for configuring and administering a Patton adapter or system. This person should have experience configuring network devices and be familiar with networking concepts. This guide is also intended for the following users:

- Operators
- Installers
- Maintenance technicians

## Structure

---

This guide contains the following chapters and appendices:

- Chapter 1 describes the DialFire RAS
- Chapter 2 contains the worksheets that will help you prepare for DialFire RAS installation
- Chapter 3 describes installing the RAS hardware
- Chapter 4 describes installing and configuring the device driver package
- Chapter 5 describes using the PattonAssist Manager
- Chapter 6 details how to power up and deactivate the RAS
- Chapter 7 contains information on contacting Patton technical support for assistance

For best results, read the contents of this guide *before* you install the DialFire RAS.

## Precautions

Notes and cautions, which have the following meanings, are used throughout this guide to help you become aware of potential RAS problems:

**Note** Calls attention to important information.



The shock hazard symbol and **WARNING** heading indicate a potential electric shock hazard. Strictly follow the warning instructions to avoid injury caused by electric shock.



The alert symbol and **WARNING** heading indicate a potential safety hazard. Strictly follow the warning instructions to avoid personal injury.



The shock hazard symbol and **CAUTION** heading indicate a potential electric shock hazard. Strictly follow the instructions to avoid property damage caused by electric shock.



The alert symbol and **CAUTION** heading indicate a potential hazard. Strictly follow the instructions to avoid property damage.

## Typographical conventions used in this document

This section describes the typographical conventions and terms used in this guide.

### General conventions

The procedures described in this manual use the following text conventions:

Table 4. General conventions

Convention	Meaning
<b>Futura bold type</b>	Indicates the names of menu bar options.
<i>Italicized Futura type</i>	Indicates the names of options on pull-down menus.
Futura type	Indicates the names of fields or windows.
Garamond bold type	Indicates the names of command buttons that execute an action.
< >	Angle brackets indicate function and keyboard keys, such as <SHIFT>, <CTRL>, <C>, and so on.
Are you ready?	All system messages and prompts appear in the Courier font as the system would display them.
% dir *.*	Bold Courier font indicates where the operator must type a response or command

**Mouse conventions**

The following conventions are used when describing mouse actions:

Table 5. Mouse conventions

Convention	Meaning
Left mouse button	This button refers to the primary or leftmost mouse button (unless you have changed the default configuration).
Right mouse button	This button refers the secondary or rightmost mouse button (unless you have changed the default configuration).
Point	This word means to move the mouse in such a way that the tip of the pointing arrow on the screen ends up resting at the desired location.
Click	Means to quickly press and release the left or right mouse button (as instructed in the procedure). Make sure you do not move the mouse pointer while clicking a mouse button.
Double-click	Means to press and release the same mouse button two times quickly
Drag	This word means to point the arrow and then hold down the left or right mouse button (as instructed in the procedure) as you move the mouse to a new location. When you have moved the mouse pointer to the desired location, you can release the mouse button.

# Chapter 1 **DialFire Model 2977 RAS Adapters**

## **Chapter contents**

- Introduction..... 13
- Model 2977 DialFire RAS overview ..... 13
  - Model 2977/B4 DialFire BRI RAS ..... 14
  - Model 2977 DialFire T1/E1 RAS ..... 14
- Supported Operating Systems..... 15

## Introduction

---

The Patton DialFire Model 2977 family of DSP-based RAS concentrator adapters are designed for such server-based applications as modem-pooling, remote access, advanced fax, World-Wide Web and branch office inter-networking.

The dense modem technology built into DialFire adapters is based on high performance digital signal processors (DSPs). On-board DSPs provide advanced modem and fax support and maximize the efficiency of each communications channel. Each DialFire channel operates independently and configures itself dynamically for analog (up to V.90 or K56flex) or digital (ISDN B-channel) support. This ensures smooth, remote connections regardless of whether callers are using analog modems or ISDN devices.

All DialFire adapters operate within the PCI 2.1 mechanical and electrical specifications, support 3.3-or 5-volt PCI and CompactPCI servers, and share a common software architecture. These features ensure compatibility with a wide variety of PCs and application software, enhance reliability, and facilitate support.

DialFire adapters integrate with the inherent communication capabilities already built into your server operating environment. DialFire drivers are written to standard APIs and are enhanced with PattonAssist management software. Using standard APIs ensures that installing and managing your ports will already be a familiar and intuitive process for network administrators. IT managers can continue to use the same management systems and administrative tools they know and trust. Users can continue to use the same remote access resources they're accustomed to since the DialFire RAS concentrators offer full modem coverage.

## Model 2977 DialFire RAS overview

---

The following Model 2977 DialFire RAS concentrator adapters are available:

- Model 2977/B4 DialFire RAS—for use in BRI RAS and fax applications (see “Model 2977/B4 DialFire BRI RAS” on page 14)
- Model 2977 DialFire RAS—for use in T1/E1 RAS and fax adapter applications (see “Model 2977 DialFire T1/E1 RAS” on page 14)

### Model 2977/B4 DialFire BRI RAS

The Model 2977 DialFire BRI RAS (see figure 1) is the ultimate WAN adapter card for use with BRI lines. It is designed to work in a standard PCI 2.1 slot (5.0 or 3.3 volts) and can terminate four BRI communication lines, allowing up to eight simultaneous digital or analog remote access connections. Calls can be originated and answered on all 8 channels (2 each for all 4 BRI connections). All channels can handle modem calls (up to 56 kbps–V.90 and K56flex) and B channel calls (64 kbps).



Figure 1. Model 2977/B4 BRI RAS

DialFire adapters support a full range of connections, from low density analog modem, to medium density Basic Rate Interface (BRI) ISDN, to high density T1/E1 and Primary Rate Interface (PRI) ISDN. Multiple DialFire adapters can be installed in a single server so capability can be added as system needs grow.

### Model 2977 DialFire T1/E1 RAS

Supporting open-standards remote access, fax, data collection, and modem pooling, the Model 2977 DialFire RAS server-based RAS (see figure 2) provides up to 60 ports in a single PCI slot.

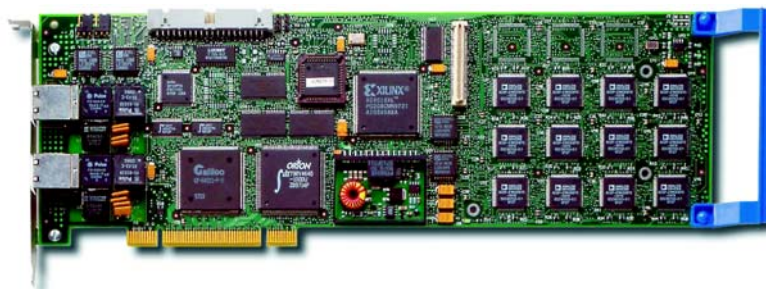

Figure 2. Model 2977 T1/E1 RAS

For demanding, server-based applications including modem-pooling, remote access, advanced fax, World Wide Web and branch office internetworking, you won't find a better product line than the Patton's Model 2977 DialFire RAS.

The Model 2977 DialFire DSP-based RAS concentrator support a full range of connections, from low density to high density T1/E1 and primary rate interface (PRI) ISDN. Multiple Model 2977 DialFire adapters can be installed in a single server so capability can be added as system needs grow.

## Supported Operating Systems

The Model 2977 DialFire RAS supports the operating systems shown in table 6.

Table 6. Supported operating systems

Platform	Operating System	Notes
<b>Microsoft</b> (primary)	Windows NT 4.0	Service Pack 4 or higher
	Windows 2000	
	Windows XP	XP driver available in beta form.
<b>Linux</b> (primary)	RedHat 5.2, 6.0, 6.1, 6.2, 7.0	These drivers have been, and shall continued to be tested for support within the Linux kernel. Additional releases maybe added.
	Debian 2.1	
	Turbo Linux Server 6.0	
	SuSE 6.4, 7.1	
<b>Sun<sup>a</sup></b> (secondary)	Solaris 2.6, 7, 8	Solaris 8 support for analog/modem fax connections only. The market for this is narrow. Analysis will be needed to evaluate. This driver maybe critical for the cPCI RAS adapters.
<b>SCO*</b> (secondary)	UnixWare 2.x, 7.x	SCO has been acquired/merged with Caldera (of Linux fame). While it appears that they are continuing the software of SCO, the market focus is on Windows and Linux platforms. We will continue to support these while analysis of the market and end-user continues.
	OpenServer 5.x	
<b>Novell*</b> (as-is)	NetWare 4.2	Novell drivers will be supported on an as-is basis and will be available.
	NetWare 5.0	There will be no further on-going development or testing of Novell drivers.
	NetWare 5.1	

a Legacy drivers available—No installation or technical support is available.

## Chapter 2 **Preparation**

### **Chapter contents**

Completing a configuration worksheet .....	17
DialFire Basic BRI Configuration Worksheet .....	18
DialFire PTE Configuration Worksheet, Channelized T1, Long Haul (External T1) .....	19
DialFire Channelized T1, Short-Haul Configuration Worksheet .....	20
DialFire PTE ISDN E1 (Euro ISDN) Configuration Worksheet .....	21
DialFire PTE ISDN T1 (PRI), Long-Haul (External T1) Configuration Worksheet.....	22
DialFire ISDN T1 (PRI), Short-Haul Configuration Worksheet.....	24



## Completing a configuration worksheet

The following worksheets are available for documenting the line provisioning for your RAS configuration:

- DialFire Basic BRI Configuration Worksheet (see page 18)
- DialFire Channelized T1, Long-Haul Configuration Worksheet (see page 19)
- DialFire Channelized T1, Short-Haul Configuration Worksheet (see page 19)
- DialFire ISDN E1 Configuration Worksheet (see page 21)
- DialFire ISDN T1 (PRI), Long-Haul Configuration Worksheet (see page 22)
- DialFire ISDN T1 (PRI), Short-Haul Configuration Worksheet (see page 22)

Refer to the appropriate worksheet and complete it, then go to chapter 3, “Installing the Model 2977 adapter” on page 26.

**Note** If you haven’t yet installed a T1 or PRI line, and need information, here are some web sites to help you get started:

North America	International
<a href="http://www.bell-atl.com">www.bell-atl.com</a>	<a href="http://www.francetelecom.com">www.francetelecom.com</a>
<a href="http://www.uswest.com">www.uswest.com</a>	<a href="http://www.telecom.co.nz">www.telecom.co.nz</a>
<a href="http://www.pacbell.com">www.pacbell.com</a>	<a href="http://www.bt.com">www.bt.com</a>
<a href="http://www.att.com">www.att.com</a>	
<a href="http://www.mci.com">www.mci.com</a>	
<a href="http://www.sprint.com">www.sprint.com</a>	
<a href="http://www.ameritech.com">www.ameritech.com</a>	
<a href="http://www.bellsouthcorp.com">www.bellsouthcorp.com</a>	
<a href="http://www.gte.com">www.gte.com</a>	
<a href="http://www.sbc.com">www.sbc.com</a>	
<a href="http://www.bell.ca">www.bell.ca</a>	

## DialFire Basic BRI Configuration Worksheet

Use the form below to gather the information that may be required to complete the configuration of your DialFire RAS B4STU adapter within your operating system environment.

**Note** Not all operating systems support all parameters.

**Note** With the exception of Modem Nationality, all parameters should be obtained from your service provider.

Parameter	Value
Switch Type	<input type="checkbox"/> 5ESS <input type="checkbox"/> DMS100 <input type="checkbox"/> ETSI (Euro ISDN) <input type="checkbox"/> INS-64 (Japan) <input type="checkbox"/> NI1 <input type="checkbox"/> None
Directory Number	List the telephone number of each logical terminal:  
SPID or Subaddress	For switch types 5ESS, DMS100, NI1 and None, list the SPID (Service Profile Identifier) for each logical terminal; for switch types ETSI (Euro ISDN) and INS-64, list the Subaddress of each logical terminal:  
Modem Nationality	Enter the country in which the RAS B4STU adapter will be installed:  
MSN (Multiple Subscriber Numbers)	Available only for ETSI (Euro ISDN) switch type, in Linux installations. <input type="checkbox"/> Disabled <input type="checkbox"/> 1-8 (specify):  
Leased Channels	List which, if any, B-channels are leased:  

After completing the worksheet, go to chapter 3, “Installing the Model 2977 adapter” on page 26.

## DialFire PTE Configuration Worksheet, Channelized T1, Long Haul (External T1)

Use the worksheet below to collect the information that may be required to complete the configuration of your DialFire PTE adapter within your operating system environment.

**Note** Not all operating systems support all parameters.

**Note** The parameters on this page are for channelized T1 connected directly to an external T1 telephone line (long haul). If your adapter is connected to a PBX or similar in-house network, use the short haul worksheet. See Channelized T1, Short Haul (PBX or Other Internal Network) on page 19.

Parameter	Value
Coding	<input type="checkbox"/> B8ZS <input type="checkbox"/> AMI
Framing	<input type="checkbox"/> ESF <input type="checkbox"/> D4
Long Haul Line Build Out (Level)	<input type="checkbox"/> 0 dB <input type="checkbox"/> 7.5 dB <input type="checkbox"/> 15 dB <input type="checkbox"/> 22.5 dB
Signaling	<input type="checkbox"/> Ground Start <input type="checkbox"/> Loop Start <input type="checkbox"/> Immediate Start <input type="checkbox"/> Wink Start – Wink Patton Electronics (1-20): _____
Leased Time Slots	List which, if any, T1 time slots are leased:
Modem Nationality	Enter the country in which the PTE adapter will be installed:

After completing the worksheet, go to chapter 3, “Installing the Model 2977 adapter” on page 26.

## DialFire Channelized T1, Short-Haul Configuration Worksheet

Use the worksheet below to collect the information that may be required to complete the configuration of your DialFire PTE adapter within your operating system environment.

**Note** Not all operating systems support all parameters.

**Note** The parameters on this page are for channelized T1 connected to a PBX or similar in-house network (Short Haul). If your adapter is connected directly to an external T1 telephone line, use the Channelized T1, Long Haul (External T1) worksheet on page 19.

Parameter	Value
Coding	<input type="checkbox"/> B8ZS <input type="checkbox"/> AMI
Framing	<input type="checkbox"/> ESF <input type="checkbox"/> D4
Short Haul Length in feet (meters)	<input type="checkbox"/> 0–133 ft (0–41 m) <input type="checkbox"/> 133–266 ft (40.5–81 m) <input type="checkbox"/> 266–399 ft (81–122 m) <input type="checkbox"/> 399–533 ft (122–162 m) <input type="checkbox"/> 533–655 ft (162–200 m)
Signaling	<input type="checkbox"/> Ground Start <input type="checkbox"/> Loop Start <input type="checkbox"/> Immediate Start <input type="checkbox"/> Wink Start – Wink Patton Electronics (1-20): _____
Leased Time Slots	List which, if any, T1 time slots are leased:
Modem Nationality	Enter the country in which the PTE adapter will be installed:

After completing the worksheet, go to chapter 3, “Installing the Model 2977 adapter” on page 26.

## DialFire PTE ISDN E1 (Euro ISDN) Configuration Worksheet

Use the worksheet below to collect the information that may be required to complete the configuration of your DialFire PTE adapter within your operating system environment.

**Note** Not all operating systems support all parameters.

**Note** The parameters on this page are for ISDN E1 (Euro ISDN).

Parameter	Value
Line Type	E1
Framing	<input type="checkbox"/> CEPT with CRC4 <input type="checkbox"/> CEPT without CRC4
Coding	<input type="checkbox"/> HDB3 <input type="checkbox"/> AMI
Signaling	<input type="checkbox"/> ETSI (Euro ISDN) <input type="checkbox"/> None
Leased Time Slots	List which, if any, E1 time slots are leased:
Modem Nationality	Enter the country in which the PTE adapter will be operated:
Before You Install the DialFire RAS B4ST Adapter...	<p><b>Order the ISDN Line</b></p> <p>If you do not have an ISDN line installed, you need to contact your telephone company and order a Basic Rate ISDN line (2B+D) with the following recommended configuration:</p> <p><b>Note</b> If your telephone company supports either of the following ISDN Ordering Codes, request that your ISDN line be configured to one of them.</p> <ul style="list-style-type: none"> <li>• <b>EZ-ISDN 1 (Preferred)</b></li> <li>• <b>Capability S</b></li> </ul> <p>If your telephone company does not support either of these Ordering Codes, request the following ISDN line configuration:</p> <ul style="list-style-type: none"> <li>• Switch Type: National ISDN 1 (preferred), ETSI, AT&amp;T 5ESS, or Nortel DMS 100</li> <li>• ISDN Basic Rate Interface (BRI) service (2B+D)</li> <li>• 2 B channels, D channel for signaling only (no D channel packet data)</li> <li>• Circuit Switched data and voice (CSD/CSV) on each channel</li> <li>• Dynamic TEI</li> <li>• Multipoint bus configuration</li> <li>• Terminal type A (AT&amp;T Custom switch only)</li> <li>• No EKTS or special services or features</li> </ul> <p><small>*You must select a long distance carrier and forward your choice, along with the Ordering Code or line configuration, to your telephone company</small></p>

After completing the worksheet, go to section chapter 3, "Installing the Model 2977 adapter" on page 26.

## DialFire PTE ISDN T1 (PRI), Long-Haul (External T1) Configuration Worksheet

Use the worksheet below to collect the information that may be required to complete the configuration of your DialFire PTE adapter within your operating system environment.

**Note** The parameters on this page are for ISDN T1 (PRI) connected directly to an external T1 telephone line (Long Haul). If your adapter is connected to a PBX or similar in-house network, use the ISDN T1 (PRI), Short Haul (PBX or Other Internal Network) configuration worksheet (page 24).

Parameter	Value		
Coding	<input type="checkbox"/> B8ZS		
Framing	<input type="checkbox"/> ESF		
Long Haul Line Build Out (Level)	<input type="checkbox"/> 0dB <input type="checkbox"/> 7.5 dB <input type="checkbox"/> 15 dB <input type="checkbox"/> 22.5 dB		
Signaling	<input type="checkbox"/> AT&T 5ESS <input type="checkbox"/> Nortel DMS 100/250 <input type="checkbox"/> ETSI (Euro ISDN) <input type="checkbox"/> INS-1500 (Japan) <input type="checkbox"/> National ISDN2 <input type="checkbox"/> None		
NFAS Master Port (RAS 48 PT2 Only)	<input type="checkbox"/> None <input type="checkbox"/> 1 <input type="checkbox"/> 2	Interface ID for Port 1 (0-127): _____	Interface ID for Port 2 (0-127): _____
Leased Time Slots	List which, if any, PRI time slots are leased:		
Modem Nationality	Enter the country in which the PTE adapter will be installed:		

Parameter	Value
Before You Install the DialFire RAS B4ST Adapter...	<p><b>Order the ISDN Line</b></p> <p>If you do not have an ISDN line installed, you need to contact your telephone company and order a Basic Rate ISDN line (2B+D) with the following recommended configuration:</p> <p><b>Note</b> If your telephone company supports either of the following ISDN Ordering Codes, request that your ISDN line be configured to one of them.</p> <ul style="list-style-type: none"> <li>• <b>EZ-ISDN 1 (Preferred)</b></li> <li>• <b>Capability S</b></li> </ul> <p>If your telephone company does not support either of these Ordering Codes, request the following ISDN line configuration:</p> <ul style="list-style-type: none"> <li>• Switch Type: National ISDN 1 (preferred), ETSI, AT&amp;T 5ESS, or Nortel DMS 100</li> <li>• ISDN Basic Rate Interface (BRI) service (2B+D)</li> <li>• 2 B channels, D channel for signaling only (no D channel packet data)</li> <li>• Circuit Switched data and voice (CSD/CSV) on each channel</li> <li>• Dynamic TEI</li> <li>• Multipoint bus configuration</li> <li>• Terminal type A (AT&amp;T Custom switch only)</li> <li>• No EKTS or special services or features</li> </ul> <p>*You must select a long distance carrier and forward your choice, along with the Ordering Code or line configuration, to your telephone company</p>

After completing the worksheet, go to chapter 3, "Installing the Model 2977 adapter" on page 26.

## DialFire ISDN T1 (PRI), Short-Haul Configuration Worksheet

Use the worksheet below to collect the information that may be required to complete the configuration of your DialFire PTE adapter within your operating system environment.

**Note** Not all operating systems support all parameters.

**Note** The parameters on this page are for ISDN T1 (PRI) connected to a PBX or similar in-house network (Short Haul). If your adapter is connected directly to an external T1 telephone line, use the ISDN T1 (PRI), Long Haul (External T1) configuration worksheet (page 22).

Parameter	Value		
Coding	<input type="checkbox"/> B8ZS		
Framing	<input type="checkbox"/> ESF		
Short Haul Length in feet (meters)	<input type="checkbox"/> 0–133 ft (0–41 m) <input type="checkbox"/> 133–266 ft (40.5–81 m) <input type="checkbox"/> 266–399 ft (81–122 m) <input type="checkbox"/> 399–533 ft (122–162 m) <input type="checkbox"/> 533–655 ft (162–200 m)		
Signaling	<input type="checkbox"/> AT&T 5ESS <input type="checkbox"/> Nortel DMS 100/250 <input type="checkbox"/> ETSI (Euro ISDN) <input type="checkbox"/> INS-1500 (Japan) <input type="checkbox"/> National ISDN2 <input type="checkbox"/> None		
NFAS Master Port (RAS 48 PT2 Only)	<input type="checkbox"/> None <input type="checkbox"/> 1 <input type="checkbox"/> 2	Interface ID for Port 1 (0–127): _____	Interface ID for Port 2 (0–127): _____
Leased Time Slots	List which, if any, PRI time slots are leased:		
Modem Nationality	Enter the country in which the PTE adapter will be installed:		



Parameter	Value
Before You Install the DialFire RAS B4ST Adapter...	<p><b>Order the ISDN Line</b></p> <p>If you do not have an ISDN line installed, you need to contact your telephone company and order a Basic Rate ISDN line (2B+D) with the following recommended configuration:</p> <p><b>Note</b> If your telephone company supports either of the following ISDN Ordering Codes, request that your ISDN line be configured to one of them.</p> <ul style="list-style-type: none"> <li>• <b>EZ-ISDN 1 (Preferred)</b></li> <li>• <b>Capability S</b></li> </ul> <p>If your telephone company does not support either of these Ordering Codes, request the following ISDN line configuration:</p> <ul style="list-style-type: none"> <li>• Switch Type: National ISDN 1 (preferred), ETSI, AT&amp;T 5ESS, or Nortel DMS 100</li> <li>• ISDN Basic Rate Interface (BRI) service (2B+D)</li> <li>• 2 B channels, D channel for signaling only (no D channel packet data)</li> <li>• Circuit Switched data and voice (CSD/CSV) on each channel</li> <li>• Dynamic TEI</li> <li>• Multipoint bus configuration</li> <li>• Terminal type A (AT&amp;T Custom switch only)</li> <li>• No EKTS or special services or features</li> </ul> <p>*You must select a long distance carrier and forward your choice, along with the Ordering Code or line configuration, to your telephone company</p>

**Note** After completing the worksheet, go to chapter 3, “Installing the Model 2977 adapter” on page 26

# Chapter 3 **Installing the Model 2977 adapter**

## **Chapter contents**

- Introduction .....27
- Model 2977 B4 ST adapter installation .....27
  - Determining your line termination requirements .....27
  - Installing the DialFire RAS B4ST Adapter .....28
- Model 2977 B4 U adapter installation .....29
- Model 2977 PE1 PE2 adapter installation .....31
- Model 2977 PT1 PT2 adapter installation .....32
- Model 2977 daughter board installation .....33
  - Parts List .....33
  - Installation .....33

## Introduction

---

This chapter contains the following procedures for installing your Model 2977 adapter. Refer to the appropriate procedure and complete it, then go to chapter 4, “Driver installation and configuration” on page 36 to install the software driver.

- Model 2977 B4 ST (see “Model 2977 B4 ST adapter installation” on page 27)
- 2977 B4 U adapter installation (see “Model 2977 B4 U adapter installation” on page 29)
- 2977 PE1 PE2 adapter installation (see “Model 2977 PE1 PE2 adapter installation” on page 31)
- 2977 PT1 PT2 adapter installation (see “Model 2977 PT1 PT2 adapter installation” on page 32)
- 2977 daughter board installation (see “Write down the serial number of the adapter in the space provided below. The serial number label has the general form: “S/N (S) XXX XXXXX”” on page 33)

## Model 2977 B4 ST adapter installation

---

The DialFire RAS B4ST adapter provides four ISDN Basic Rate Interface (2B+D) lines in a package that fits in a single PCI slot in your server.

This section describes how to install your DialFire RAS B4ST adapter.

### **Determining your line termination requirements**

ISDN Basic Rate Lines must be terminated. By default, the DialFire RAS B4ST adapter terminates the BRI line with a 100-ohm resistor across the transmit and receive lines. In most cases, no changes are required. In the event that multiple ISDN S/T devices are installed on the same ISDN BRI line, only one device (the device farthest from the NT1) should be terminated. If the DialFire RAS B4ST is not that device, you will need to change the switch setting from *Terminated* to *Open* (see Step 8 of the Installation procedure). Ensure that the terminating resistors in the farthest ISDN device are enabled, and that the NT1 is set to 100-ohm termination.

The terminating switches must be changed in pairs (one for transmit and one for receive), as shown in figure 3. The figure shows the switches set for no termination (OFF position). To terminate the lines, place the switches in the ON position (down, or toward the board).

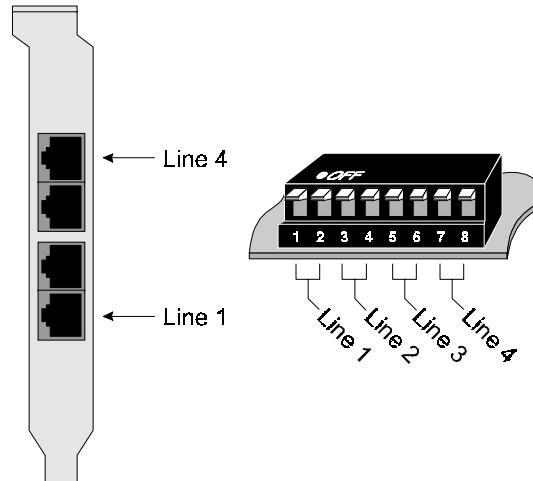

Figure 3. DialFire BRI connectors and line-terminating DIP switch

### Installing the DialFire RAS B4ST Adapter

Do the following:

1. Unplug power from the computer.
2. Remove the computer's cover.
3. Put on the wrist strap (included in your DialFire RAS package) and attach it to the computer's chassis.



To guard against damage to the DialFire RAS adapter due to electrostatic discharge (ESD), do not remove the adapter from its protective packaging until you have grounded yourself to the computer chassis

4. Locate an available full-length PCI slot in your computer and remove the slot plate.
5. Remove the DialFire RAS adapter from its protective packaging.
6. Write down the serial number of the adapter in the space provided below. The serial number label has the general form: "S/N (S) XXX XXXXX"

Serial Number: \_\_\_\_\_

7. Insert the adapter into the slot and screw the endplate to the computer chassis. The endplate must be screwed into the computer chassis to remain in compliance with Part 15 of FCC rules.
8. Set the BRI line termination DIP switches according to your configuration.

9. Replace the computer's cover.
10. Connect the telephone line(s) to the adapter (see figure 3 on page 28 for connector locations).

Adapter installation is complete. Refer to Chapter 4, "Driver installation and configuration".

## Model 2977 B4 U adapter installation

The DialFire RAS B4ST adapter provides four ISDN Basic Rate Interface (2B+D) lines in a package that fits in a single PCI slot in your server.

This section describes how to install your DialFire RAS B4ST adapter.

Do the following:

1. Unplug power from the computer.
2. Remove the computer's cover.
3. Put on the wrist strap (included in your DialFire RAS package) and attach it to the computer's chassis.



To guard against damage to the DialFire RAS adapter due to electrostatic discharge (ESD), do not remove the adapter from its protective packaging until you have grounded yourself to the computer chassis

4. Locate an available full-length PCI slot in your computer and remove the slot plate.
5. Remove the DialFire RAS adapter from its protective packaging.
6. Write down the serial number of the adapter in the space provided below. The serial number label has the general form: "S/N (S) XXX XXXXX"

Serial Number: \_\_\_\_\_

7. Insert the adapter into the slot and screw the endplate to the computer chassis. The endplate must be screwed into the computer chassis to remain in compliance with Part 15 of FCC rules.
8. Replace the computer's cover.

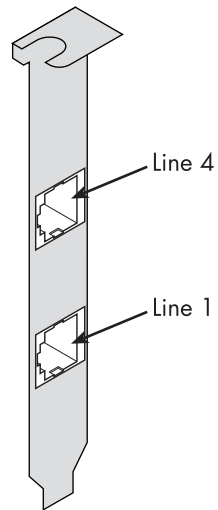

Figure 4. DialFire BRI connectors

9. Connect the telephone line(s) to the adapter (see figure 4 for connector locations). Adapter installation is complete. Refer to Chapter 4, “Driver installation and configuration”.

## Model 2977 PE1 PE2 adapter installation

The DialFire RAS PTE Series adapters provide one or two 30B+D PRI interfaces in a package that fits in a single PCI slot in your server.

Because it uses DSP (digital signal processor) technology, the DialFire RAS adapter supports digital or analog connections on PRI circuits. The adapter supports up to 30 channels on each line.

The position of the PRI connectors is shown in figure 5.

**Note** Line 1 and Line 2 connectors are present on RAS PE1 and RAS PE2 adapters, but only Line 1 is active on RAS PE1 adapters. A RAS PE1 adapter may be field-upgraded to RAS PE2 by the addition of a daughter card

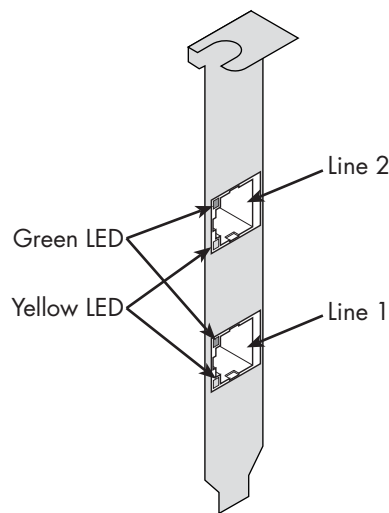

Figure 5. PE1 & PE2 Connector Locations

Do the following:

1. Unplug power from the computer.
2. Remove the computer's cover.



**CAUTION**

To guard against damage to the DialFire RAS adapter due to electrostatic dis-charge (ESD), do not remove the adapter from its protective packaging until you have grounded yourself to the computer chassis

3. Put on the wrist strap (included in your DialFire RAS package) and attach it to the computer's chassis.
4. Locate an available full-length PCI slot in your computer and remove the slot plate.
5. Remove the DialFire RAS adapter from its protective packaging.

- Write down the serial number of the adapter in the space provided below. The serial number label has the general form: “S/N (S) XXX XXXXX”

Serial Number: \_\_\_\_\_

- Insert the adapter into the slot and screw the endplate to the computer chassis.
- Replace the computer’s cover.
- Connect the PRI line(s) to the adapter. If the adapter is a RAS PE1, only Line 1 (see figure 5 on page 31) is active. If the adapter is a RAS PE2, two PRI lines are supported and both connectors may be used.

Adapter installation is complete. Refer to Chapter 4, “Driver installation and configuration”.

## Model 2977 PT1 PT2 adapter installation

The DialFire RAS PTE Series adapters provide one or two 30B+D PRI interfaces in a package that fits in a single PCI slot in your server.

Because it uses DSP (digital signal processor) technology, the DialFire RAS adapter supports digital or analog connections on PRI circuits. The adapter supports up to 30 channels on each line.

The position of the PRI connectors is shown in figure 6.

**Note** Line 1 and Line 2 connectors are present on RAS PT1 and RAS PT2 adapters, but only Line 1 is active on RAS PT1 adapters. A RAS PT1 adapter may be field-upgraded to RAS PT2 by the addition of a daughter card

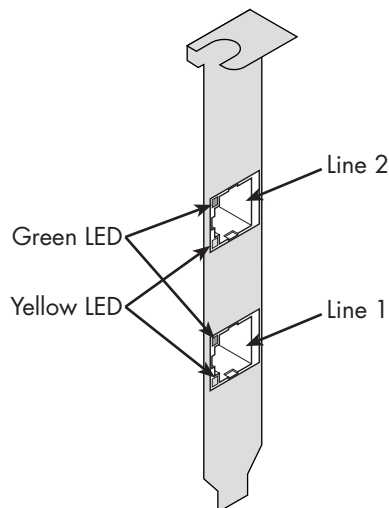

Figure 6. PT1 & PT2 Connector Locations

Do the following:

- Unplug power from the computer.
- Remove the computer’s cover.





To guard against damage to the DialFire RAS adapter due to electrostatic discharge (ESD), do not remove the adapter from its protective packaging until you have grounded yourself to the computer chassis

3. Put on the wrist strap (included in your DialFire RAS package) and attach it to the computer's chassis.
4. Locate an available full-length PCI slot in your computer and remove the slot plate.
5. Remove the DialFire RAS adapter from its protective packaging.
6. Write down the serial number of the adapter in the space provided below. The serial number label has the general form: "S/N (S) XXX XXXXX"

Serial Number: \_\_\_\_\_

7. Insert the adapter into the slot and screw the endplate to the computer chassis.
8. Replace the computer's cover.
9. Connect the PRI line(s) to the adapter. If the adapter is a RAS PT1, only Line 1 (see figure 6 on page 32) is active. If the adapter is a RAS PT2, two PRI lines are supported and both connectors may be used.

Adapter installation is complete. Refer to Chapter 4, "Driver installation and configuration".

## Model 2977 daughter board installation

You can activate the second port on your DialFire PT1 or PE1 adapter by adding a daughter card. This section provides instructions for installing the daughter card on PCI and CompactPCI (cPCI) adapters.

### Parts List

- DialFire PTE series daughter card
- Spacers, quantity: 4
- Screws, quantity: 8
- Wrist strap for static protection

### Installation

1. If your DialFire adapter is currently installed in your system, follow the normal procedure to prepare your system for hardware removal or exchange.
2. Put on the wrist strap (included with the adapter) and attach it to the system chassis.



For ESD protection, do not touch the DialFire adapter or the daughter card until you have grounded yourself to the system chassis

3. Remove the DialFire adapter from the system (if installed).

4. Remove the daughter card from its ESD protective packaging.
5. Using the screws provided, attach the four spacers to the DialFire adapter, on the side with the connector, as shown in figure 7 (below) and figure 8 on page 35. Be sure to install the spacers on the plated through-holes.
6. Plug the daughter card onto the DialFire adapter (see figure 7 and figure 8). The spacers should line up with the plated through-holes on the daughter card.

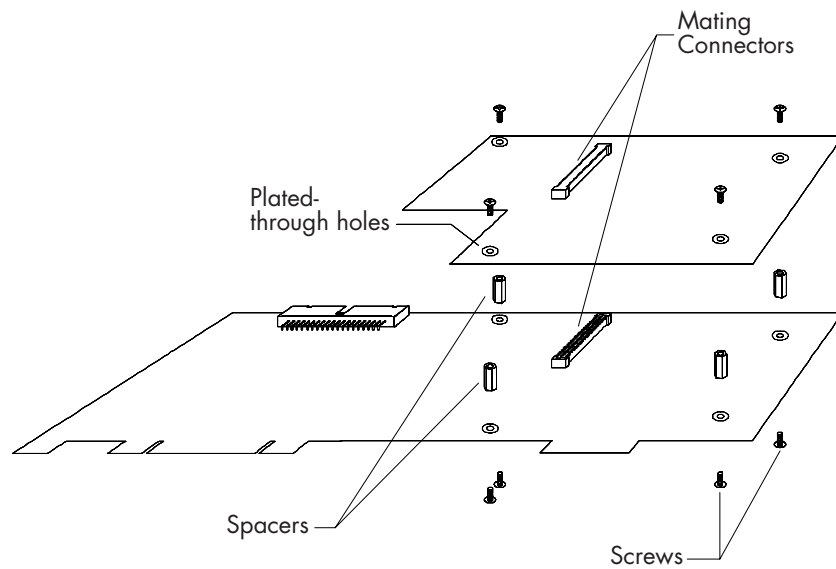

Figure 7. PCI Board: Installing the Daughter Card on the DialFire PTE Adapter

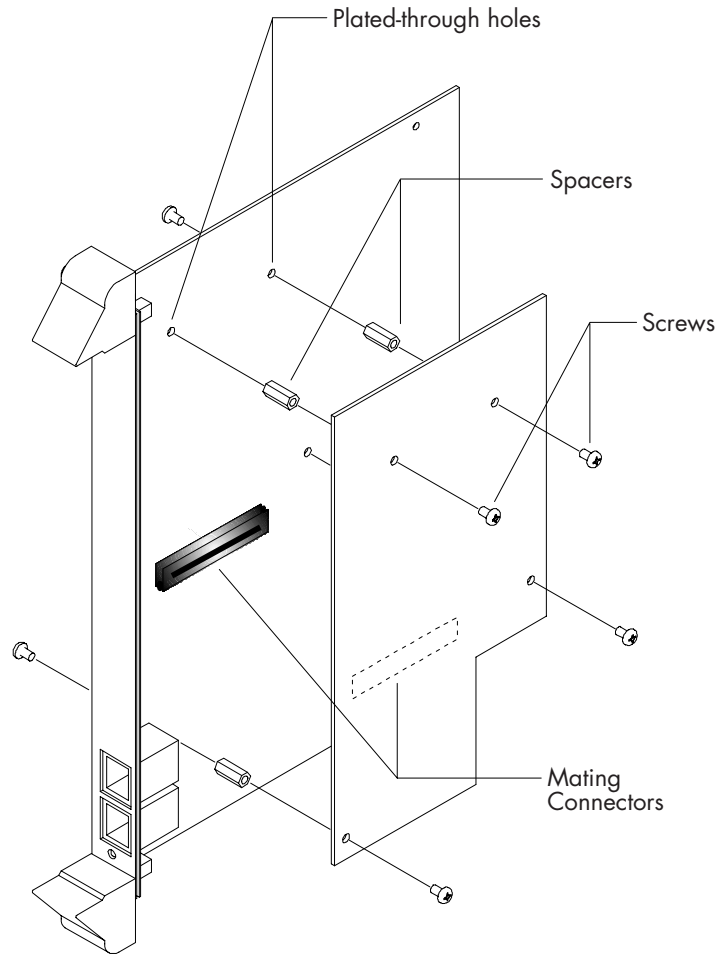

Figure 8. CompactPCI (cPCI) Board: Installing the Daughter Card on the DialFire PTE Adapter

7. Secure the daughter card to the adapter with the remaining four screws.
8. Install the adapter in your computer or store it in a static dissipating sleeve for ESD protection before removing the wrist strap.
9. Record the adapter serial number in the space provided below. The serial number label has the following general form: S/N (S) XXX XXXXX

Serial Number: \_\_\_\_\_

Daughter card installation is complete.

# Chapter 4 **Driver installation and configuration**

## **Chapter contents**

Introduction .....	38
Driver installation for the Windows 2000 operating system .....	38
Supported Products .....	38
Requirements .....	38
Procedure .....	38
Installing the Driver .....	38
Procedure .....	39
Upgrading the Driver .....	39
Procedure .....	39
Driver installation for the Windows XP operating system .....	40
Additional Notes .....	41
Configuring Incoming Dial-up Networking Connections .....	41
Procedure .....	41
Configuring Outgoing Dial-up Networking Connections .....	41
Procedure .....	42
Changing Adapter Properties .....	42
Procedure .....	42
Changing Phone and Modem Options .....	42
Procedure .....	42
Uninstalling the Driver .....	43
Procedure .....	43
Using the Windows Troubleshooter .....	43
Procedure .....	43
Driver installation for the Microsoft Windows NT operating system.....	44
Installing the downloaded driver .....	44
Procedure .....	44
Installing the MS Loopback Adapter .....	44
Procedure .....	44
Configuring the Adapter: First Time .....	45
Procedure .....	45
Changing the Adapter Configuration .....	45
Procedure .....	45
Configuring RAS Ports .....	45
Procedure .....	45
Configuring RAS Dial-in Permissions .....	46
Procedure .....	47
Configuring Dial-up Networking Connections .....	47
Procedure .....	47

Configuring Modems on COM Ports .....47  
    Procedure .....47  
Uninstalling the Driver .....47  
    Procedure .....47  
Changing Serial Port Names .....48  
    Procedure .....48

## Introduction

---

This chapter contains the following procedures for installing and configuring your Model 2977 software driver. Refer to the appropriate procedure and complete it, then go to chapter 5, “Using the Viewer” on page 49 to install the PattonAssist Manager.

- Microsoft Windows 2000 installation (see “Driver installation for the Windows 2000 operating system”)
- Microsoft Windows NT (see “Driver installation for the Microsoft Windows NT operating system” on page 44)

## Driver installation for the Windows 2000 operating system

---

This section describes installing and configuring the DialFire device driver package.

### Supported Products

Use this documentation to help you install and configure Windows 2000 device drivers for the following Patton RAS products:

- DialFire RAS PT1&PT2 & PE1&PE2
- DialFire RAS B4ST\U adapters

### Requirements

The following factors affect the process of installing or upgrading Patton device drivers:

- New Patton drivers are available online at [www.patton.com/support/upgrades](http://www.patton.com/support/upgrades).
- Patton drivers for Microsoft Windows 2000 may be either signed or unsigned.
- Some Patton adapters may have an outdated driver in the Windows 2000 driver database, which must be replaced when you install the adapter.
- A Patton device driver often supports multiple types of adapters. It is possible for driver version conflicts to occur, depending on the specific combination of adapters and drivers in your system.

Windows 2000 Plug and Play installation, while appropriate for most devices, does not resolve conflicts resulting from these factors.

For most Patton adapters, a configuration wizard starts automatically as part of the installation or upgrade process. You may need to step through configuration wizards for your installed adapters, but your current configuration parameters remain intact unless you make changes.

### Procedure

1. Install the adapter. See the appropriate hardware installation card for information.

**Note** When you install multiple PCI adapters of the same type on a Windows system, it is sometimes difficult to determine which adapter you are configuring. To avoid confusion, you may wish to install and configure the adapters one at a time.

### Installing the Driver

Use this procedure to install a Patton device driver on Microsoft Windows 2000.

**Note** If you installed your adapter before performing this procedure, go to *Completing an Installation* instead.

### *Procedure*

1. Ensure that Windows 2000 is running on your system.
2. Install the adapter according to the hardware installation instructions.
3. Apply power to the system and start Windows 2000. Select the location where the driver is located.
4. If the driver is unsigned, choose **Yes** to continue through each of the **Digital Signature Not Found** warnings. This ensures that the most current driver software is installed.
5. Follow the instructions to complete the installation. For most Patton adapters, a configuration wizard starts automatically as part of the installation process.

When the installation is complete, the adapter is ready to use. There is no need to restart Windows unless you are notified to do so.

### **Upgrading the Driver**

Use this procedure to upgrade Patton device drivers for Microsoft Windows 2000 adapters already installed in your system.

Because a Patton device driver often supports multiple types of adapters, you must use the Patton Driver Upgrade Wizard to upgrade drivers. The wizard resolves possible driver conflicts and ensures that the correct drivers install for the Patton adapters in your system.

Patton drivers are available online at [www.patton.com/support/upgrades](http://www.patton.com/support/upgrades). Patton drivers for Windows 2000 may be either signed or unsigned.

### *Procedure*

To update a previously installed Digi device driver to a new Patton device driver, do the following:

1. First, run the program `padrcln.cmd` to remove the existing INF files for the adapter. This ensures that the new driver files will be installed instead of the old driver files. `padrcln.cmd` is part of the driver software package and can be found in the same directory as the new driver files.
2. Next, navigate to the Device Manager and locate the adapter whose device driver is to be updated:
  - From the Desktop, right-click on **My Computer**
  - Select **Manage**
  - In the left-hand side of the Computer Management window, select **Device Manager**

Locate the adapter to update:

- In the right-hand side of the window, expand the **Network adapters** category.
- Right-click on the device to update
- Choose **Properties**

Begin the upgrade process:

- Click the **Driver** tab

- Click the **Update Driver...** button
  - Click **Next >**
  - Verify that the default option is selected, "Search for a suitable driver for my device (recommended)"
  - Click **Next >**
  - Deselect all options
  - Select the option, **Specify a location**
  - Click **Next >**
  - Enter the path to the new driver files and click **OK**
  - Click **Next >**
3. Windows may display a **Digital Signature Not Found** message, explaining that the driver is not signed. Click **Yes** to continue the installation. One may see several of these warnings—simply click **Yes** for each message to proceed with the upgrade.
  4. Windows will now install the new device driver for the adapter and its modems.
  5. Follow any other instructions to complete the installation.
  6. Click **Finish** to dismiss the Upgrade Device Driver Wizard.
  7. Repeat steps 2 through 6 for each device to be upgraded.

### **Driver installation for the Windows XP operating system**

This section describes installing and configuring the DialFire device driver package.

1. First, run the program `padrcln.cmd` to remove the existing INF files for the adapter. This ensures that the new driver files will be installed instead of the old driver files. `padrcln.cmd` is part of the driver software package and can be found in the same directory as the new driver files.
2. Next, navigate to the Device Manager and locate the device whose device driver is to be updated:
  - Open the Start menu
  - Right-click **My Computer**
  - Select **Manage**
  - In the left-hand side of the Computer Management window, select **Device Manager**

Locate the adapter to update:

- In the right-hand side of the window, expand the **Network adapters** category.
- Right-click on the device to update
- Choose **Properties**

Begin the upgrade process:

- Click the **Driver** tab
- Click the **Update Driver...** button



- Click **Next >**
  - Verify that the default option is selected, "Search for a suitable driver for my device (recommended)"
  - Click **Next >**
  - Deselect all options
  - Select the option, **Specify a location**
  - Click **Next >**
  - Enter the path to the new driver files and click **OK**
  - Click **Next >**
3. Windows will display a dialog indicating that the software has not passed Windows Logo testing. Choose **Continue Anyway** to proceed with the upgrade. One may see several of these warnings—click **Continue Anyway** for each message to continue the installation.
  4. Windows will now install the new device driver for the adapter and its modems.
  5. Follow any other instructions to complete the installation.
  6. Click **Finish** to dismiss the Upgrade Device Driver Wizard.
  7. Repeat steps 2 through 6 for each device to be upgraded.

#### *Additional Notes*

This driver has not been signed by Microsoft WHQL.

On-line help is available when you install the product.

Additional installation documentation can be found on Patton's Web site, [www.patton.com](http://www.patton.com).

### **Configuring Incoming Dial-up Networking Connections**

Use this procedure to configure incoming Dial-up Networking connections from other systems to your server. You should have already installed the Patton adapter and device driver.

#### *Procedure*

1. From the Start menu, choose **Settings > Network and Dial-up Connections**.
2. Choose **Make New Connection** to start the Network Connection Wizard.
3. Choose **Accept incoming connections** and complete the wizard.
4. From the **Start** menu, choose **Settings > Control Panel > Administrative Tools > Routing and Remote Access**. You can use the Routing and Remote Access control panel to monitor communications activity on the server.

If you have not yet configured your system as a Remote Access Server, choose **Action > Add server**, and follow the on-screen instructions.

### **Configuring Outgoing Dial-up Networking Connections**

Use this procedure to configure outgoing Dial-up Networking connections from your server to other systems. You should have already installed the Patton adapter and device driver.

### Procedure

1. From the **Start** menu, choose **Settings > Network and Dial-up Connections**.
2. Choose **Make New Connection** to start the Network Connection Wizard.
3. Choose **Dial-up to private network** and complete the wizard.
4. Upon completion of the wizard, choose **Properties** if you wish to configure dialing rules (such as what number to dial to get an outside line) or to add alternate phone numbers to try if the primary number is busy.

### Changing Adapter Properties

Use this procedure to change the configuration of an installed adapter.

### Procedure

1. From the **Start** menu, choose **Settings > Control Panel > System > Hardware > Device Manager**.
2. From the displayed list, choose DialFire RAS as your network adapter.
3. Choose the Patton adapter you wish to configure.
4. From the Action menu, choose **Properties > Advanced**.
5. Configure the adapter as necessary.
6. If you changed the hardware resources from the default settings, Windows may notify you to restart the system to complete the configuration.

If you left the hardware resources at their default values, the adapter is ready to use without restarting the system.

### Changing Phone and Modem Options

Use this procedure once you have installed and configured the driver and now want to change the configuration.

Phone and modem options that can be set with this procedure include:

- Maximum Port Speed
- Speaker Volume
- Dial Control
- Wait for tone before dialing
- Extra Initialization Commands

### Procedure

1. From the **Start** menu, choose **Settings > Control Panel > Phone and Modem Options > Modems**.
2. Choose a Patton modem device to configure.
3. Choose **Properties**.
4. Configure the options as necessary. Refer to Windows Help for more information.

### **Uninstalling the Driver**

Use this procedure to uninstall the Microsoft Windows 2000 device driver.

#### *Procedure*

1. From the **Start** menu, choose **Settings > Control Panel > Add/Remove Hardware > Next**.
2. Choose **Uninstall/Unplug a device > Next**.
3. Choose **Uninstall a device > Next**.
4. Choose the device you wish to uninstall, then choose **Next > Yes > Next > Finish**.

**Note** To prevent the driver from being automatically reinstalled when you restart Windows, shut down Windows, turn off the computer and remove the adapter. If you wish to disable the driver without physically removing the adapter, choose Unplug a device in Step 3.

### **Using the Windows Troubleshooter**

Use this procedure to help resolve any basic installation or configuration problems with a Microsoft Windows 2000 or Microsoft Windows NT adapter.

#### *Procedure*

1. From the Start menu, select **Control Panel > System > Hardware > Device Manager**.
2. From the displayed list, choose DialFire RAS as your network adapter.
3. Choose a Patton adapter.
4. Choose **Actions > Properties > General** to view the Device Status window.
5. If the Device Status window indicates that the device is not operating properly, choose **Troubleshooting** and follow the instructions. Use Windows Help for more information.

## Driver installation for the Microsoft Windows NT operating system

---

### Installing the downloaded driver

This section describes installing and configuring the DialFire device driver package. Use this procedure to install a driver that you have downloaded from the Patton Support website ([www.patton.com/support/upgrades](http://www.patton.com/support/upgrades)).

**Note** If you are installing multiple adapters, each adapter needs to be installed separately. You need to restart your computer before installing another adapter.

#### Procedure

1. Log on to Windows NT as Administrator.
2. From **Start**, choose **Settings > Control Panel > Network > Adapters**.
3. Do one of the following:
  - If this is the first time you have installed this driver, choose **Add > Have Disk**.
  - If you have installed an earlier version of this driver, choose **Update**.
4. Enter the path to where the driver is stored and then choose **OK**.
5. Choose the driver and then **OK**.
6. Choose **OK** on the Setup screen to complete installation.  
The adapter appears on the Network Adapters list.
7. Choose **Close** and restart the computer.

### Installing the MS Loopback Adapter

Use this procedure to install the MS Loopback Adapter.

#### Procedure

1. From the Windows NT Control Panel, choose **Network**.  
The system displays the following prompt: *Windows NT Networking is not installed. Do you want to install it now?*
2. Choose **Yes**.  
The system asks if your computer is wired to the network or connected via Remote Access (modem).
3. Choose **Wired** to the Network > Next > Select from list.
4. Choose **MS Loopback Adapter** from the dialog box and **Next**.
5. Choose **NetBEUI** as the network protocol and then **Next**.
6. Install the default network services by choosing **Next > Next**.  
The system asks for a directory path.

7. Enter either **d:\386\** (for Intel processors; use **d:\alpha\** for Alpha systems) and load your Windows NT CD-ROM. (This assumes that your CD-ROM drive is drive D.)

The system asks you to specify a Frame Type.

8. Choose **802.3** and then **Continue**.

The network bindings page appears.

9. Choose **Next** to accept the bindings and **Next** again to start the network.

10. Enter the name of your computer and workgroup and click **Next**.

11. Restart your computer to activate Windows NT Networking.

### **Configuring the Adapter: First Time**

Use this procedure to configure a Patton Electronics adapter for the first time.

#### *Procedure*

1. Install the driver. Refer to “Installing the downloaded driver” on page 44.
2. Use the configuration wizard and online Help to guide you through initial configuration.

### **Changing the Adapter Configuration**

Use this procedure to change the configuration of a previously-configured Patton Electronics adapter.

#### *Procedure*

1. Access the configuration utility by choosing **Control Panel > Network > Adapters**.
2. Choose the adapter from the list and then Properties. The adapter properties page appears.
3. Select an item to reconfigure from the left-hand pane of the properties page and then choose **Properties**.
4. Change the configuration as required and then choose **OK**.

### **Configuring RAS Ports**

Use this procedure to configure Patton Electronics devices as RAS ports (sometimes called RAS capable devices).

#### *Procedure*

1. If you need to access Windows NT RAS, choose **Control Panel > Network > Services > Remote Access Services > Properties**.
2. To add a modem port to the RAS configuration, do the following:
  - Choose **Add > Install Modem**.
  - Choose <Don't detect my modem; I will select it from a list> and then choose **Next**.
  - Choose **Patton Electronics International** from the Manufacturer's list and **Patton Electronics RAS 56K Modem** from the Model's list and then choose **Next**.
  - Install this modem type on the ports you want to use for RAS and then follow the prompts until you get to the Add RAS Device dialog.
  - From the Add RAS Device dialog, choose devices to add to RAS and then **OK**.

- Configure a RAS device by doing the following:
    - o Choose the device and then **Configure**.
    - o Configure the device as desired.
    - o Choose **OK**.
  - If all devices are to be configured the same, use **Clone**. Otherwise, repeat these steps for each device.
3. If you have a RAS B or RAS PTE adapter and want to add an ISDN port (B-channel) to the RAS configuration, do the following:
    - Choose **Add**.
    - Choose a device from the list in RAS Capable Devices and then choose **OK**.
    - Install this device on the ports you want to use for RAS and then follow the prompts until you get to the Add RAS Device dialog.
    - From the **Add RAS Device** dialog, choose devices to add to RAS and then **OK**.
    - Configure a RAS device by doing the following:
      - o Choose the device and then **Configure**.
      - o Configure the device as desired.
      - o Choose **OK**.
    - If all devices are to be configured the same, use **Clone**. Otherwise, repeat these steps for each device.
  4. If you have an adapter and want to add an X.25 switched virtual circuit (SVC) or a PPP device to the RAS configuration, do the following:
    - Choose **Add**.
    - Choose an X.25 SVC or a Patton Electronics PPP device from the list in RAS Capable Devices and then **OK**.
  5. To configure the network protocols to use over a port, do the following:
    - Choose the port.
    - Choose the Network button to access the protocol-specific configuration.
    - Use Microsoft's help text to guide you through the network protocol configuration. If you plan to use Multilink PPP over this connection, ensure that Multilink is selected.
  6. Choose **Continue** to finish RAS configuration.
  7. Close the Microsoft Network applet.
  8. Reboot when prompted to do so.

### Configuring RAS Dial-in Permissions

Use this procedure to configure dial-in permissions for Microsoft Windows NT RAS ports.

**Note** If you are using RAS, use the User Manager for Domains to configure RAS dial-in permissions. See the Microsoft help text for more information.

### Procedure

1. Access the RAS Admin utility by choosing **Start > Programs > Administrative Tools > Remote Access Admin**.
2. Choose **Users > Permission** from the menu.
3. Configure permission. Use Microsoft Windows NT online help for information.

### Configuring Dial-up Networking Connections

Use this procedure to configure Dial-up Networking connections for a Patton Electronics adapter.

### Procedure

1. To access the Dial-up Networking utility, double-click **My Computer** and then **Dial-up Networking**.
2. Choose **New**.
3. Fill out configuration fields. Here are a few tips:
  - If you will use more than one telephone number to make the connection, do the following: (a) Fill in the telephone number (b) Choose the **Alternate** button, (c) Add numbers. (d) Choose **OK** when you are done.
  - In the **Dial-up using** field, specify the device that will be used for the connection.
  - If you want to configure a Multilink connection, do the following: (1) Choose **Multiple Lines** in the **Dial-up using** field. This entry will appear only if you have configured the connection in RAS for Multilink. (2) Choose **Configure**. (3) Check any channels that are to be part of the multilink connection.
  - When providing telephone numbers, remember the following: (a) You may have to include the number 9 or some other digit to get an outside line if your site uses a PBX or Centrex service. (b) For ISDN connections, do not use spaces, dashes, or commas in the telephone number. (c) If this is a long distance call, be sure the telephone number includes the number 1 and an area code.
  - When selecting ISDN Devices, select the line type ordered from your service provider.
4. Choose **OK > Close**.

### Configuring Modems on COM Ports

Use this procedure to configure a Patton Electronics modem as a Microsoft Windows NT COM port.

### Procedure

1. Choose **Control Panel > Modems > Add**.
2. Check **Don't detect my modem; I will select it from a list** and then choose **Next**.
3. Choose the Patton Electronics modem and then **Next**.
4. Choose COM ports on which to install the modem and then **Next > Finish**.

### Uninstalling the Driver

Use this procedure to uninstall a Microsoft Windows NT driver.

### Procedure

1. Open the Windows NT Control Panel.
2. Choose **Network > Adapters**.

3. Highlight the adapter and choose **Remove**.
4. If you have installed external modems on an AccelePort Xp adapter or if you have configured internal modems on AccelePort or DialFire adapters, remove them from the Windows NT Modem list by doing the following:
  - From the Control Panel, choose **Modems**.
  - Choose the modem to remove, then choose **Remove**.
5. Restart Windows NT to complete the removal process.

### **Changing Serial Port Names**

Use this procedure to change the name of a serial port in Microsoft Windows NT.

#### *Procedure*

1. Access the configuration utility by choosing **Control Panel > Network > Adapters**.
2. Choose your adapter from the list and then **Properties**.

The adapter properties page appears.
3. If necessary, expose individual serial ports by clicking the + (plus sign) at the left of the Serial label.
4. Choose a port to rename and then **Properties**.
5. Supply a new name and then choose **OK**.



# Chapter 5 **Using the Viewer**

## **Chapter contents**

About Patton View .....	50
Starting Patton View .....	50

## About Patton View

---

Patton View is a diagnostic utility—currently available only for the Microsoft Windows 2000 operating system—that provides tools to monitor and troubleshoot Patton adapter connections. Patton Viewer includes the following features:

- Line monitoring that includes information on each line and virtual circuit, and on the various protocol layers
- Line tracing
- Trace filtering tools that allow you to eliminate unwanted information from the display of information captured during a trace
- Trace analysis tools that allow you to easily identify individual fields within captured frames
- Graphical user interface and context-sensitive help

To use PattonAssist Viewer, see section “Starting Patton View”.

### Starting Patton View

To start PattonAssist Viewer do the following:

1. From the **Start** menu choose **Run**.
2. Enter the program name **Pattonview**.
3. Patton Viewer will start. For detailed information on Patton View tools, choose Help.

# Chapter 6 **Operation and shutdown**

## **Chapter contents**

Activating the Model 2977 .....52  
De-activating the Model 2977 .....52

## **Activating the Model 2977**

---

The Model 2977 RAS activates automatically when power is applied to computer in which the RAS is installed.

## **De-activating the Model 2977**

---

To de-activate a Model 2977 RAS, the computer in which the RAS is installed must be powered-off. Follow the appropriated directions for shutting-down the computer.

# Chapter 7 **Contacting Patton for assistance**

## **Chapter contents**

- Introduction..... 54
- Contact information..... 54
- Warranty Service and Returned Merchandise Authorizations (RMAs)..... 54
  - Warranty coverage ..... 54
    - Out-of-warranty service ..... 54
    - Returns for credit ..... 54
    - Return for credit policy ..... 55
  - RMA numbers ..... 55
  - Shipping instructions ..... 55

## Introduction

---

This chapter contains the following information:

- “Contact information”—describes how to contact PATTON technical support for assistance.
- “Warranty Service and Returned Merchandise Authorizations (RMAs)” —contains information about the RAS warranty and obtaining a return merchandise authorization (RMA).

## Contact information

---

Patton Electronics offers a wide array of free technical services. If you have questions about any of our other products we recommend you begin your search for answers by using our technical knowledge base. Here, we have gathered together many of the more commonly asked questions and compiled them into a searchable database to help you quickly solve your problems.

- Online support—available at [www.patton.com](http://www.patton.com).
- E-mail support—e-mail sent to [support@patton.com](mailto:support@patton.com) will be answered within 1 business day
- Telephone support—standard telephone support is available 5 days a week, from 8:00am to 5:00pm EST by calling +1 (301) 975-1007

## Warranty Service and Returned Merchandise Authorizations (RMAs)

---

Patton Electronics is an ISO-9001 certified manufacturer and our products are carefully tested before shipment. All of our products are backed by a comprehensive warranty program.

**Note** If you purchased your equipment from a Patton Electronics reseller, ask your reseller how you should proceed with warranty service. It is often more convenient for you to work with your local reseller to obtain a replacement. Patton services our products no matter how you acquired them.

### Warranty coverage

Our products are under warranty to be free from defects, and we will, at our option, repair or replace the product should it fail within one year from the first date of shipment. Our warranty is limited to defects in workmanship or materials, and does not cover customer damage, lightning or power surge damage, abuse, or unauthorized modification.

### *Out-of-warranty service*

Patton services what we sell, no matter how you acquired it, including malfunctioning products that are no longer under warranty. Our products have a flat fee for repairs. Units damaged by lightning or other catastrophes may require replacement.

### *Returns for credit*

Customer satisfaction is important to us, therefore any product may be returned with authorization within 30 days from the shipment date for a full credit of the purchase price. If you have ordered the wrong equipment or you are dissatisfied in any way, please contact us to request an RMA number to accept your return. Patton is not responsible for equipment returned without a Return Authorization.

### *Return for credit policy*

- Less than 30 days: No Charge. Your credit will be issued upon receipt and inspection of the equipment.
- 30 to 60 days: We will add a 20% restocking charge (crediting your account with 80% of the purchase price).
- Over 60 days: Products will be accepted for repairs only.

### **RMA numbers**

RMA numbers are required for all product returns. You can obtain an RMA by doing one of the following:

- Completing a request on the RMA Request page in the *Support* section at [www.patton.com](http://www.patton.com)
- By calling +1 (301) 975-1000 and speaking to a Technical Support Engineer
- By sending an e-mail to [returns@patton.com](mailto:returns@patton.com)

All returned units must have the RMA number clearly visible on the outside of the shipping container. Please use the original packing material that the device came in or pack the unit securely to avoid damage during shipping.

### *Shipping instructions*

The RMA number should be clearly visible on the address label. Our shipping address is as follows:

#### **Patton Electronics Company**

RMA#: xxxx

7622 Rickenbacker Dr.

Gaithersburg, MD 20879-4773 USA

Patton will ship the equipment back to you in the same manner you ship it to us. Patton will pay the return shipping costs.

## Appendix A **Software License Agreements**

---

### **Chapter contents**

Agreement for using the DialFire driver software with the Microsoft Windows 2000 operating system .....	57
Agreement for using the DialFire driver software with the Microsoft Windows NT operating system .....	58



## Agreement for using the DialFire driver software with the Microsoft Windows 2000 operating system

---

**LICENSE.** Patton Electronics Company, Inc. grants to you only a non-assignable, nonexclusive and non-transferable license to use the software contained on this media (hereinafter "Patton Software") subject to the terms and conditions of this Software License Agreement. Your use will be limited to an object code version of the Patton Software. Your use of the Patton Software will be limited to one computer. The license will commence on the day you receive the Patton Software and will continue until this license is terminated by its own terms and conditions. You may make one copy of the Patton Software, but only for archival or backup purposes, and if you do make that additional copy, you agree to reproduce all copyright and other proprietary rights notices that appear on the Patton Software. You are granted only a limited license to use the Patton Software, and Patton retains all right, title, interest and ownership in and to the Patton Software, which includes all rights arising under the patent, copyright, trade secret or trademark laws of the United States or any foreign jurisdiction.

**CONFIDENTIALITY.** You understand and agree that the Patton Software contains valuable confidential and trade secret information which is the extremely valuable property of Patton. You agree to expend all necessary efforts to ensure that the Patton Software is not disclosed or made available to any third party or any employee or contractor that doesn't have a need to know.

**REVERSE ENGINEERING.** You agree not to disassemble, decompile or reverse engineer the Patton Software under any circumstances.

**WARRANTIES.** Patton warrants only that: (a) the media upon which you receive Patton Software will be free of defects in material and workmanship for a period of ninety (90) days from your receipt of the Patton Software; and (b) that if the Patton Software is supplied to you electronically, and there is an error in transmission, and you inform us of that error within ninety days of your receipt of the Patton Software, Patton will re-transmit the Software to you. YOU UNDERSTAND AND AGREE THAT EXCEPT AS STATED ABOVE, THE PATTON SOFTWARE IS SUPPLIED 'AS IS,' AND PATTON EXPRESSLY DISCLAIMS ALL OTHER WARRANTIES, GUARANTEES, OR REMEDIES WHETHER EXPRESS, IMPLIED OR STATUTORY, INCLUDING, BUT NOT LIMITED TO, ANY IMPLIED WARRANTY OF MERCHANTABILITY OR FITNESS FOR A PARTICULAR PURPOSE.

**LIABILITY LIMITATIONS.** UNDER NO CIRCUMSTANCES WILL PATTON OR ANY OF ITS DISTRIBUTORS OR SUPPLIERS BE LIABLE FOR LOSS OF DATA, REPROCUREMENT COSTS, LOST REVENUE OR PROFITS OR ANY OTHER SPECIAL, INCIDENTAL OR CONSEQUENTIAL DAMAGES, EVEN IF THOSE DAMAGES WERE FORESEEABLE OR YOU HAVE INFORMED PATTON OF POTENTIAL LIABILITY. PATTON'S TOTAL LIABILITY TO YOU FOR DAMAGES FOR ANY REASON SHALL NOT EXCEED THE PRICE ACTUALLY PAID TO PATTON BY YOU FOR THE PRODUCT ASSOCIATED WITH THE SOFTWARE.

**TITLE AND OWNERSHIP.** You acknowledge and agree that Patton retains all right, title and interest in and to the Software. You agree to indemnify, defend and hold harmless Patton against any loss suffered or expenditure made by Patton arising from an assertion of an interest in or title to the Patton Software by you and against any breach by you of any copyright, patent rights, or any other rights in the Patton Software.

**TERMINATION.** You acknowledge and agree that Patton may terminate your license and use of the Patton Software without notice if, at any time, you fail to comply with a material term or condition of this Software License Agreement. Immediately upon termination of this license, you will return all copies of the Patton Software to Patton, together with all documentation, modifications and enhancements thereto, or at Patton's

request, destroy all copies of the Patton Software documentation, modifications and enhancements in your possession. You understand and agree that in the event of termination, Patton may use computer hardware, software or other methods to render the Patton Software inoperable.

**ASSIGNMENT.** You may not assign this license without the prior written consent of Patton. Patton may assign the Patton Software to any third party at its discretion, but will provide you with written notice in the event of such assignment.

**CHOICE OF LAW AND VENUE.** This Software License Agreement shall be governed and construed in accordance with the laws of the State of Minnesota. Any controversy or claim arising out of or related to this license and/or your use of the Patton Software shall be venued in Minnesota State District Court, County of Hennepin or the United States District Court for the District of Minnesota.

**MAINTENANCE AND SUPPORT.** Any software maintenance or support services provided to you by Patton, are provided at Patton's discretion, and Patton reserves the right to discontinue and/or commence charging fees for maintenance or support services at any time. You also understand and agree that any maintenance or support services provided to you by Patton are provided as is, and Patton makes no representations or warranties with regard to those services.

## **Agreement for using the DialFire driver software with the Microsoft Windows NT operating system**

---

**LICENSE.** Patton Electronics grants to you only a non-assignable, nonexclusive and non-transferable license to use the software contained on this media (hereinafter "Patton Electronics Software") subject to the terms and conditions of this Software License Agreement. Your use will be limited to an object code version of the Patton Electronics Software. Your use of the Patton Electronics Software will be limited to one computer. The license will commence on the day you receive the Patton Electronics Software and will continue until this license is terminated by its own terms and conditions. You may make one copy of the Patton Electronics Software, but only for archival or backup purposes, and if you do make that additional copy, you agree to reproduce all copyright and other proprietary rights notices that appear on the Patton Electronics Software. You are granted only a limited license to use the Patton Electronics Software, and Patton Electronics retains all right, title, interest and ownership in and to the Patton Electronics Software, which includes all rights arising under the patent, copyright, trade secret or trademark laws of the United States or any foreign jurisdiction.

**CONFIDENTIALITY.** You understand and agree that the Patton Electronics Software contains valuable confidential and trade secret information which is the extremely valuable property of Patton Electronics. You agree to expend all necessary efforts to ensure that the Patton Electronics Software is not disclosed or made available to any third party or any employee or contractor that doesn't have a need to know.

**REVERSE ENGINEERING.** You agree not to disassemble, decompile or reverse engineer the Patton Electronics Software under any circumstances.

**WARRANTIES.** Patton Electronics warrants only that: (a) the media upon which you receive Patton Electronics Software will be free of defects in material and workmanship for a period of ninety (90) days from your receipt of the Patton Electronics Software; and (b) that if the Patton Electronics Software is supplied to you electronically, and there is an error in transmission, and you inform us of that error within ninety days of your receipt of the Patton Electronics Software, Patton Electronics will re-transmit the Software to you. **YOU UNDERSTAND AND AGREE THAT EXCEPT AS STATED ABOVE, THE PATTON ELECTRONICS SOFTWARE IS SUPPLIED 'AS IS,' AND PATTON ELECTRONICS EXPRESSLY DISCLAIMS ALL OTHER WARRANTIES, GUARANTEES, OR REMEDIES WHETHER EXPRESS, IMPLIED OR**

STATUTORY, INCLUDING, BUT NOT LIMITED TO, ANY IMPLIED WARRANTY OF MERCHANTABILITY OR FITNESS FOR A PARTICULAR PURPOSE.

**LIABILITY LIMITATIONS.** UNDER NO CIRCUMSTANCES WILL PATTON ELECTRONICS OR ANY OF ITS DISTRIBUTORS OR SUPPLIERS BE LIABLE FOR LOSS OF DATA, REPROCUREMENT COSTS, LOST REVENUE OR PROFITS OR ANY OTHER SPECIAL, INCIDENTAL OR CONSEQUENTIAL DAMAGES, EVEN IF THOSE DAMAGES WERE FORESEEABLE OR YOU HAVE INFORMED PATTON ELECTRONICS OF POTENTIAL LIABILITY. PATTON ELECTRONICS'S TOTAL LIABILITY TO YOU FOR DAMAGES FOR ANY REASON SHALL NOT EXCEED THE PRICE ACTUALLY PAID TO PATTON ELECTRONICS BY YOU FOR THE PRODUCT ASSOCIATED WITH THE SOFTWARE.

**TITLE AND OWNERSHIP.** You acknowledge and agree that Patton Electronics retains all right, title and interest in and to the Software. You agree to indemnify, defend and hold harmless Patton Electronics against any loss suffered or expenditure made by Patton Electronics arising from an assertion of an interest in or title to the Patton Electronics Software by you and against any breach by you of any copyright, patent rights, or any other rights in the Patton Electronics Software.

**TERMINATION.** You acknowledge and agree that Patton Electronics may terminate your license and use of the Patton Electronics Software without notice if, at any time, you fail to comply with a material term or condition of this Software License Agreement. Immediately upon termination of this license, you will return all copies of the Patton Electronics Software to Patton Electronics, together with all documentation, modifications and enhancements thereto, or at Patton Electronics's request, destroy all copies of the Patton Electronics Software documentation, modifications and enhancements in your possession. You understand and agree that in the event of termination, Patton Electronics may use computer hardware, software or other methods to render the Patton Electronics Software inoperable.

**ASSIGNMENT.** You may not assign this license without the prior written consent of Patton Electronics. Patton Electronics may assign the Patton Electronics Software to any third party at its discretion, but will provide you with written notice in the event of such assignment.

**CHOICE OF LAW AND VENUE.** This Software License Agreement shall be governed and construed in accordance with the laws of the State of Minnesota. Any controversy or claim arising out of or related to this license and/or your use of the Patton Electronics Software shall be venued in Minnesota State District Court, County of Hennepin or the United States District Court for the District of Minnesota.

**MAINTENANCE AND SUPPORT.** Any software maintenance or support services provided to you by Patton Electronics, are provided at Patton Electronics's discretion, and Patton Electronics reserves the right to discontinue and/or commence charging fees for maintenance or support services at any time. You also understand and agree that any maintenance or support services provided to you by Patton Electronics are provided as is, and Patton Electronics makes no representations or warranties with regard to those services.