

Models 3034/3038

Multiport Asynchronous Statistical Multiplexer

Getting Started Guide



Important

This is a Class A device and is intended for use in a light industrial environment. It is not intended nor approved for use in an industrial or residential environment.

Sales Office: +1 (301) 975-1000
Technical Support: +1 (301) 975-1007
E-mail: support@patton.com
WWW: www.patton.com

Part Number: **07M3038-GS, Rev. B**
Revised: **June 8, 2009**

Patton Electronics Company, Inc.

7622 Rickenbacker Drive
Gaithersburg, MD 20879 USA
Tel: +1 (301) 975-1000
Fax: +1 (301) 869-9293
Support: +1 (301) 975-1007
Web: www.patton.com
E-mail: support@patton.com

Copyright © 2009, Patton Electronics Company. All rights reserved.

The information in this document is subject to change without notice. Patton Electronics assumes no liability for errors that may appear in this document.

Warranty Information

The software described in this document is furnished under a license and may be used or copied only in accordance with the terms of such license. For information about the license, see [Appendix E, "End user license agreement"](#) on page 56 or go to www.patton.com.

Patton Electronics warrants all 3034/3038 components to be free from defects, and will—at our option—repair or replace the product should it fail within one year from the first date of the shipment.

This warranty is limited to defects in workmanship or materials, and does not cover customer damage, abuse or unauthorized modification. If the product fails to perform as warranted, your sole recourse shall be repair or replacement as described above. Under no condition shall Patton Electronics be liable for any damages incurred by the use of this product. These damages include, but are not limited to, the following: lost profits, lost savings and incidental or consequential damages arising from the use of or inability to use this product. Patton Electronics specifically disclaims all other warranties, expressed or implied, and the installation or use of this product shall be deemed an acceptance of these terms by the user.

Summary Table of Contents

- 1 General information 13
- 2 Applications overview..... 19
- 3 Model 3034/3038 installation 21
- 4 Initial configuration 29
- 5 RS-232 port configuration 33
- 6 Sync Serial Configuration 37
- 7 Contacting Patton for assistance 40
- A Compliance information 43
- B Specifications 46
- C Cabling 49
- D Port pin-outs 52
- E End user license agreement 56

Table of Contents

Summary Table of Contents	3
Table of Contents	4
List of Figures	7
List of Tables	8
About this guide	9
Audience.....	9
Structure.....	9
Precautions	10
Safety when working with electricity	11
General observations	11
Typographical conventions used in this document.....	12
General conventions	12
1 General information.....	13
Model 3034/3038 Overview.....	14
Features and Benefits.....	15
Model 3034/3038 Features	15
Rear and Front Panels.....	16
Model 3034/3038 rear panel	16
Model 3034/3038 front panel	18
2 Applications overview.....	19
Typical Model 3034/3038 Application.....	20
3 Model 3034/3038 installation.....	21
Planning the installation	22
Site log	22
Network information	22
Network Diagram	22
IP related information	23
Software tools	23
Power source	23
Location and mounting requirements	23
Installing the Model 3034/3038.....	23
Placing the Model 3034/3038	23
Installing cables	24
Connecting the RS-232 ports	24
Connecting the 10/100Base-T Ethernet LAN and WAN cables	25
Connecting the Composite port	25
Models with a V.35 port (3034/C and 3038/C)	25
Models with an X.21 port (3034/D and 3038/D)	25
Models with a T1/E1 port and BNC Connectors (3034/K and 3038/K)	25

Connecting the power supply	26
Internal AC Power Supply	27
External AC Power Supply	27
External DC Power Supply	28
4 Initial configuration	29
Introduction	30
1. Connecting the Model 3034/3038 to your PC	30
Connecting and logging in via the Ethernet port	30
Connecting and logging in via the Console port	31
2. Configuring the desired IP address	31
Factory-default IP settings	31
Login	32
Changing the IP address	32
Saving the IP address	32
3. Connecting the Model 3034/3038 to the network	32
5 RS-232 port configuration	33
Overview	34
Configuration Overview	34
Web Management Interface (WMI)	35
Port Configuration	35
Command Line Interface (CLI)	36
6 Sync Serial Configuration	37
Overview	38
Configuration Overview	38
Web Management Interface (WMI)	38
Command Line Interface (CLI)	39
7 Contacting Patton for assistance	40
Introduction	41
Contact information	41
Patton support headquarters in the USA	41
Alternate Patton support for Europe, Middle East, and Africa (EMEA)	41
Warranty Service and Returned Merchandise Authorizations (RMAs)	41
Warranty coverage	41
Out-of-warranty service	42
Returns for credit	42
Return for credit policy	42
RMA numbers	42
Shipping instructions	42
A Compliance information	43
Compliance	44
EMC	44
Safety	44

PSTN Regulatory	44
Radio and TV Interference	44
FCC Part 68 (ACTA) Statement	44
Industry Canada Notice	45
CE Declaration of Conformity	45
Authorized European Representative	45
B Specifications	46
RS-232 Ports	47
Composite Ports	47
Ethernet Ports	47
Serial Console Port	47
Commands	47
IP Services	48
IP Connectivity	48
Operating Environment	48
System	48
C Cabling	49
Introduction	50
Console	50
Ethernet	51
D Port pin-outs	52
Introduction	53
Console port	53
Ethernet	54
V.35 (DB-25 connector)	54
X.21 (DB-15 connector)	55
T1/E1	55
RS-232	55
E End user license agreement	56
End User License Agreement	57
1. Definitions	57
2. Title	57
3. Term	57
4. Grant of License	57
5. Warranty	57
6. Termination	58
7. Other licenses	58

List of Figures

1	Model 3038	14
2	3038 rear panels	16
3	Model 3038 front panel	18
4	Typical application for Model 3034/3038	20
5	Connecting the RS-232 ports	24
6	V.35 interface models	25
7	X.21 interface models	25
8	T1/E1 interface models	26
9	Connecting DC Power to the 3034/3038 DC Power Supply	28
10	Connecting the Model 3034/3038 to your laptop PC via the Ethernet port	30
11	Connecting the Model 3034/3038 to your laptop PC via the console port	31
12	3034/3038 networking diagram	34
13	Terminal Configuration	35
14	Sync Serial Device Management page	38
15	Connecting a serial terminal	50
16	Typical Ethernet straight-through cable diagram for 10/100Base-T	51
17	EIA-561 (RJ-45 8-pin) port	53

List of Tables

1	General conventions	12
2	Model 3034/3038 Model Codes	15
3	Rear panel ports	17
4	LED Descriptions	18
5	Sample site log entries	22
6	Factory default IP address and network mask configuration	31
7	Stat Mux- CLI Commands	36
8	Stat Mux- CLI Commands	39
9	RJ45 socket 10/100Base-T	54
10	RJ45 socket 1000Base-T	54

About this guide

This guide describes the Model 3034/3038 hardware, installation and basic configuration.

Audience

This guide is intended for the following users:

- Operators
- Installers
- Maintenance technicians

Structure

This guide contains the following chapters and appendices:

- [Chapter 1](#) on page 13 provides information about router features and capabilities
- [Chapter 2](#) on page 19 contains an overview describing router operation and applications
- [Chapter 3](#) on page 21 provides hardware installation procedures
- [Chapter 4](#) on page 29 provides quick-start procedures for configuring the Model 3034/3038
- [Chapter 5](#) on page 33 provides information for configuring the RS-232 ports via the CLI or the WMI
- [Chapter 7](#) on page 40 contains information on contacting Patton technical support for assistance
- [Appendix A](#) on page 43 contains compliance information for the router
- [Appendix B](#) on page 46 contains specifications for the routers
- [Appendix C](#) on page 49 provides cable recommendations
- [Appendix D](#) on page 52 describes the router's ports and pin-outs
- [Appendix E](#) on page 56 provides license information that describes acceptable usage of the software provided with the Model 3034/3038

For best results, read the contents of this guide *before* you install the router.

Precautions

Notes, cautions, and warnings, which have the following meanings, are used throughout this guide to help you become aware of potential problems. **Warnings** are intended to prevent safety hazards that could result in personal injury. **Cautions** are intended to prevent situations that could result in property damage or impaired functioning.

Note A note presents additional information or interesting sidelights.



IMPORTANT

The alert symbol and IMPORTANT heading calls attention to important information.



CAUTION

The alert symbol and CAUTION heading indicate a potential hazard. Strictly follow the instructions to avoid property damage.



CAUTION

The shock hazard symbol and CAUTION heading indicate a potential electric shock hazard. Strictly follow the instructions to avoid property damage caused by electric shock.



WARNING

The alert symbol and WARNING heading indicate a potential safety hazard. Strictly follow the warning instructions to avoid personal injury.



WARNING

The shock hazard symbol and WARNING heading indicate a potential electric shock hazard. Strictly follow the warning instructions to avoid injury caused by electric shock.

Safety when working with electricity



- **This device contains no user serviceable parts. The equipment shall be returned to Patton Electronics for repairs, or repaired by qualified service personnel.**
- **Mains Voltage:** Line voltages are present when the power cord is connected. The mains outlet shall be within 10 feet (3 meters) of the device, shall be easily accessible, and protected by a circuit breaker.
- **For AC powered units, ensure that the power cable used meets all applicable standards for the country in which it is to be installed, and that it is connected to a wall outlet which has earth ground.**
- **Hazardous network voltages are present in WAN ports, regardless of whether power to the unit is ON or OFF. To avoid electric shock, use caution when near WAN ports. When detaching the cables, detach the end away from the unit first.**
- **Do not work on the system or connect or disconnect cables during periods of lightning activity.**
- **For units with an external power adapter, the adapter shall be a listed Limited Power Source.**



In accordance with the requirements of council directive 2002/96/EC on Waste of Electrical and Electronic Equipment (WEEE), ensure that at end-of-life you separate this product from other waste and scrap and deliver to the WEEE collection system in your country for recycling.

General observations

- Clean the case with a soft slightly moist anti-static cloth
- Place the unit on a flat surface and ensure free air circulation
- Avoid exposing the unit to direct sunlight and other heat sources
- Protect the unit from moisture, vapors, and corrosive liquids

Typographical conventions used in this document

This section describes the typographical conventions and terms used in this guide.

General conventions

The procedures described in this manual use the following text conventions:

Table 1. General conventions

Convention	Meaning
Garamond blue type	Indicates a cross-reference hyperlink that points to a figure, graphic, table, or section heading. Clicking on the hyperlink jumps you to the reference. When you have finished reviewing the reference, click on the Go to Previous View button  in the Adobe® Acrobat® Reader toolbar to return to your starting point.
Futura bold type	Commands and keywords are in boldface font.
<i>Futura bold-italic type</i>	Parts of commands, which are related to elements already named by the user, are in boldface italic font.
<i>Italicized Futura type</i>	Variables for which you supply values are in <i>italic</i> font
Futura type	Indicates the names of fields or windows.
Garamond bold type	Indicates the names of command buttons that execute an action.
< >	Angle brackets indicate function and keyboard keys, such as <SHIFT>, <CTRL>, <C>, and so on.
[]	Elements in square brackets are optional.
{a b c}	Alternative but required keywords are grouped in braces ({ }) and are separated by vertical bars ()
screen	Terminal sessions and information the system displays are in <i>screen</i> font.
node	The leading IP address or nodename of a Model 3034/3038 is substituted with node in boldface italic font.
SN	The leading SN on a command line represents the nodename of the Model 3034/3038
#	An hash sign at the beginning of a line indicates a comment line.

Chapter 1 **General information**

Chapter contents

Model 3034/3038 Overview.....	14
Features and Benefits.....	15
Model 3034/3038 Features	15
Rear and Front Panels.....	16
Model 3034/3038 rear panel	16
Model 3034/3038 front panel	18

Model 3034/3038 Overview

The Model 3034/3038 Series Multiport Asynchronous Statistical Multiplexer (figure 1) consolidates up to eight asynchronous data sources onto a single synchronous WAN link or IP/Ethernet LAN connection for secure, reliable, and transparent multiplexing.

The Model 3038 offers advanced network and transmission options. The integrated composite port provides a standard synchronous link connection to NTUs, DSUs or traditional WAN services. By including an Ethernet port as a composite uplink, the Model 3038 also “future proofs” your legacy equipment. Now multiplexed data can use existing LAN, WAN and Internet connections...simultaneously. Data security and service quality is ensured with IPSec encryption as well as packet labeling and integrated data QoS with flow-control.

Reliable data is ensured via multiple CRC-16 checks, transparent data checksums and in-order data delivery. In the event of an error, the Model 3038 automatically retransmits the data to insure transparent and error free delivery. With user configurable flow control including software XON/XOFF, hardware RTS/CTS and combination provides optimal data transfer.

Integrated management offers both local and remote configuration, control and troubleshooting. Use the supervisory port for out-of-band access or use LAN based services such as Telnet, WEB/HTTP and SNMP. Per-port options allow for diagnostics loops, traffic statistics, review channel status and monitor ports and events.



Figure 1. Model 3038

Features and Benefits

The Model 3034/3038 series consists of several models (table 2). They differ in the number of RS-232 ports and the type of composite port. All models come equipped with two 10/100/1000Base-T Ethernet ports.

Table 2. Model 3034/3038 Model Codes

Model	Ethernet Ports	RS-232 Ports	Composite Port
3034/C	2	4	V.35
3034/D	2	4	X.21
3034/K	2	4	T1/E1
3038/C	2	8	V.35
3038/D	2	8	X.21
3038/K	2	8	T1/E1

Model 3034/3038 Features

- **Eight Ports on a Single Link**—Multiplex up to eight EIA-232/V.24 ports at 230.4kbps with individually configurable speed, flow control, echo and testing.
- **E1/T1/X.21/V.35/Ethernet Composite**—Connect to any synchronous dedicated WAN or lower costs using standard PPP or Frame Relay networks. Ethernet/IP can be used over any network or Internet without the expense of dedicated lines. .
- **Ethernet/IP Networking**—User configurable IP services ensure reliable connectivity to any LAN or WAN. NAT, DHCP and Firewall permits advanced networking and flexibility.
- **Data Integrity & Encryption**—Ensure data with CRC-16 and reliable transport. Data is secure end-to-end using IPSEC with DES/3DES or AES options and auto MDI-X.
- **Local & Remote Management**—Configure and control with Web-based management, SNMP or command line supervisory port all with password protection.

Rear and Front Panels

Model 3034/3038 rear panel

The Model 3034/3038 rear panel ports are described in [table 3](#).

Note The Model 3038 rear panels are shown below. The Model 3034 is similar, except that 3034 models only have four RS-232 ports.

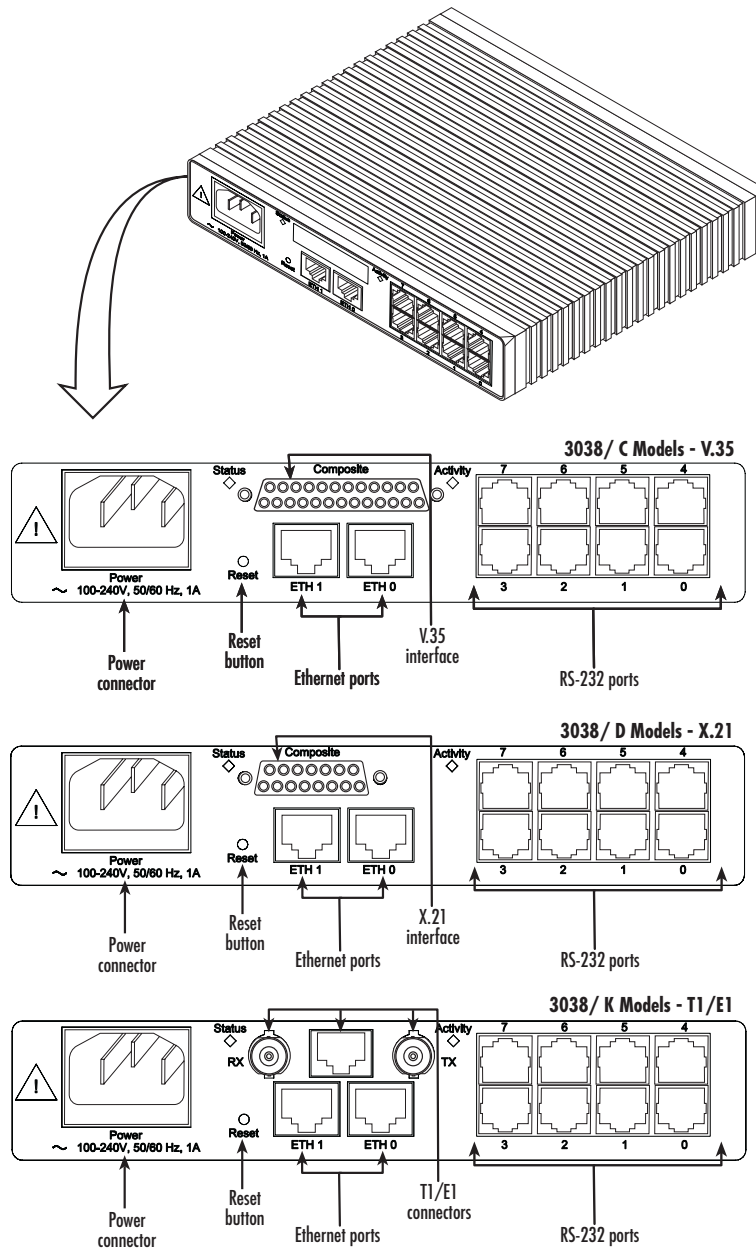

Figure 2. 3038 rear panels

Table 3. Rear panel ports

Port	Description
LAN ETH 0	Auto-MDX Ethernet port, RJ-45
LAN ETH 1	Auto-MDX Ethernet port, RJ-45
Composite	Varies depending on model type: <ul style="list-style-type: none"> • /C models: V.35 DTE interface on a DB-25 female connector • /D models: X.21 interface on a DB-15 female connector • /K models: T1/E1 interface on dual BNC connectors and an RJ-45 connector
RS-232 0-7	Four (Models 3034) to eight (Models 3038) serial asynchronous RS-232 ports with an 8-pin RJ-45F interface
Console	Used for service and maintenance, the Console port, an RS-232 RJ-45 connector, connects the product to a serial terminal such as a PC or ASCII terminal (also called a dumb terminal).
100-240 VAC 50-60 Hz	Electricity supply socket for main power cable.

Model 3034/3038 front panel

Figure 3 shows Model 3034/3038 LEDs, the LED definitions are listed in table 4.

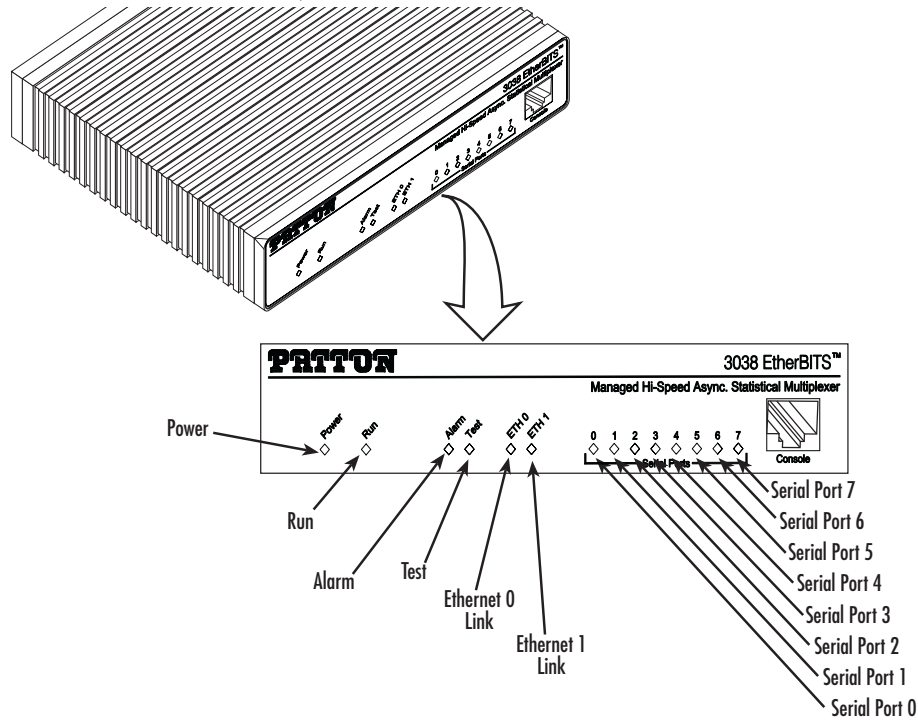

Figure 3. Model 3038 front panel

Table 4. LED Descriptions

LED	Description
Note	If an error occurs, all LEDs will flash once per second.
Power	When lit, indicates power is applied.
Run	When lit, the unit is in normal operation. Flashes once per second during boot (startup).
Alarm	When flashing, errors are occurring on one or more of the serial interfaces.
Test	When lit, a test function, such as serial interface loopback, is in operation.
Ethernet Link	On when the Ethernet connection on the corresponding port has a link indication.
Serial Link/Status	<ul style="list-style-type: none"> Off = No frames detected Flashing = Frames received/transmitted

Chapter 2 **Applications overview**

Chapter contents

Typical Model 3034/3038 Application.....20

Typical Model 3034/3038 Application

The Model 3034/3038 IpStatmux Managed Multiport Asynchronous Multiplexer combines up to eight EIA-232/V.24 interfaces over any composite V.35, X.21, E1/T1 or Ethernet/IP port and offers the lowest-cost, most flexible solution for multiport asynchronous terminal connectivity. Figure 4 shows the 3034/3038 application for remote office and branch office voice extension and access.

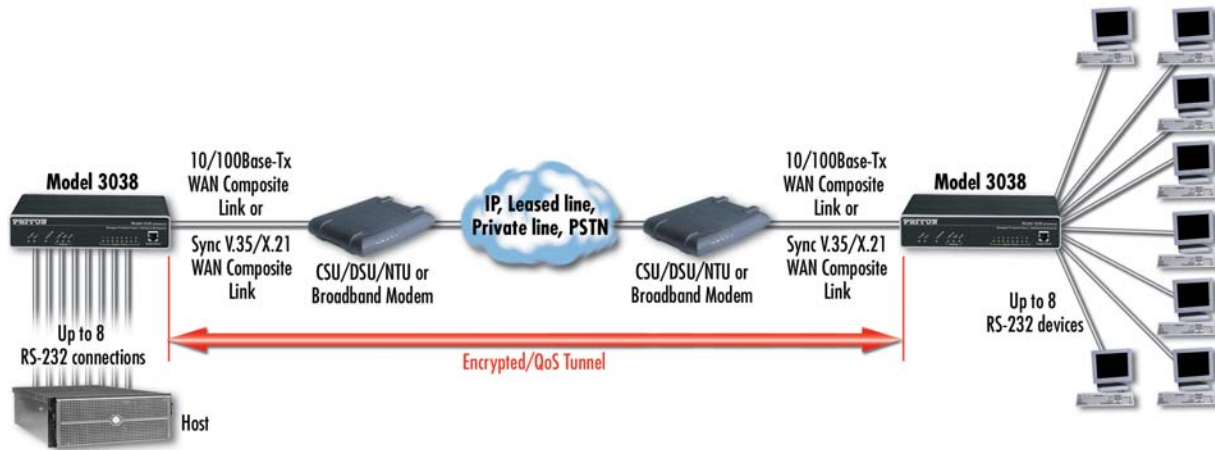

Figure 4. Typical application for Model 3034/3038

Chapter 3 **Model 3034/3038 installation**

Chapter contents

Planning the installation	22
Site log	22
Network information	22
Network Diagram	22
IP related information	23
Software tools	23
Power source	23
Location and mounting requirements	23
Installing the Model 3034/3038	23
Placing the Model 3034/3038	23
Installing cables	24
Connecting the RS-232 ports	24
Connecting the 10/100Base-T Ethernet LAN and WAN cables	25
Connecting the Composite port	25
Models with a V.35 port (3034/C and 3038/C)	25
Models with an X.21 port (3034/D and 3038/D)	25
Models with a T1/E1 port and BNC Connectors (3034/K and 3038/K).....	25
Connecting the power supply	26
Internal AC Power Supply.....	27
External AC Power Supply	27
External DC Power Supply	28

Planning the installation

Before installing the 3034/3038, the following tasks should be completed:

- **Create a network diagram** (see section “[Network information](#)” on page 22)
- **Gather IP related information** (see section “[IP related information](#)” on page 23 for more information)
- **Install the hardware and software needed to configure the Model 3034/3038.** (See section “[Software tools](#)” on page 23)
- **Verify power source reliability** (see section “[Power source](#)” on page 23).

After you have finished preparing for installation, go to section “[Installing the Model 3034/3038](#)” on page 23 to install the device.

Site log

Patton recommends that you maintain a site log to record all actions relevant to the system, if you do not already keep such a log. Site log entries should include information such as listed in [table 5](#).

Table 5. Sample site log entries

Entry	Description
Installation	Make a copy of the installation checklist and insert it into the site log
Upgrades and maintenance	Use the site log to record ongoing maintenance and expansion history
Configuration changes	Record all changes and the reasons for them
Maintenance	Schedules, requirements, and procedures performed
Comments	Notes, and problems
Software	Changes and updates to software

Network information

Network connection considerations that you should take into account for planning are provided for several types of network interfaces are described in the following sections.

Network Diagram

Draw a network overview diagram that displays all neighboring IP nodes, connected elements and telephony components.

IP related information

Before you can set up the basic IP connectivity for your Model 3034/3038 you should have the following information:

- IP addresses used for Ethernet LAN and WAN ports
- Subnet mask used for Ethernet LAN and WAN ports
- Login and password for PPPoE Access
- IP addresses of central TFTP server used for configuration upload and download (optional)

Software tools

You will need a PC (or equivalent) with Windows Telnet or a program such as *Tera Term Pro Web* (included on the Model 3034/3038 CD-ROM) to configure the software on your Model 3034/3038 router.

You may also use a web browser to configure the software using the built-in web management interface.

Power source

If you suspect that your AC power is not reliable, for example if room lights flicker often or there is machinery with large motors nearby, have a qualified professional test the power. Patton recommends that you include an uninterruptible power supply (UPS) in the installation to ensure that service is not impaired if the power fails.

Location and mounting requirements

The Model 3034/3038 router is intended to be placed on a desktop or similar sturdy, flat surface that offers easy access to the cables. Allow sufficient space at the rear of the chassis for cable connections. Additionally, you should consider the need to access the unit for future upgrades and maintenance.

Installing the Model 3034/3038

Model 3034/3038 hardware installation consists of the following:

- Placing the device at the desired installation location (see section “Placing the Model 3034/3038” on page 23)
- Connecting the interface and power cables (see section “Installing cables”)

When you finish installing the Model 3034/3038, go to chapter 4, “Initial configuration” on page 29.

Placing the Model 3034/3038

Place the unit on a desktop or similar sturdy, flat surface that offers easy access to the cables. The unit should be installed in a dry environment with sufficient space to allow air circulation for cooling.

Note For proper ventilation, leave at least 2 inches (5 cm) to the left, right, front, and rear of the unit.

Installing cables



Do not work on the system or connect or disconnect cables during periods of lightning activity.

Connect the cables in the following order:



The interconnecting cables shall be acceptable for external use and shall be rated for the proper application with respect to voltage, current, anticipated temperature, flammability, and mechanical serviceability.

1. Connect the twisted pair cables to the RS-232 ports (see “Connecting the RS-232 ports” on page 24).
2. Connect the 10/100/1000Base-T Ethernet LAN and WAN (see section “Connecting the 10/100Base-T Ethernet LAN and WAN cables” on page 25).
3. Connect the composite port (see “Connecting the Composite port” on page 25).
4. Connect the power mains cable (see section “Connecting the power supply” on page 26).

Connecting the RS-232 ports

Model 3034 has four RS-232 ports. Model 3038 has eight RS-232 ports.

To connect the twisted pair cable to the RS-232 port:

1. Attach the male connector of the twisted pair cable to the female connector on the unit.
2. Attach the other end of the cable to a local RS-232 device. If the local device has a DB-9 connector, use an RJ-45 to DB-9 converter for the connection.

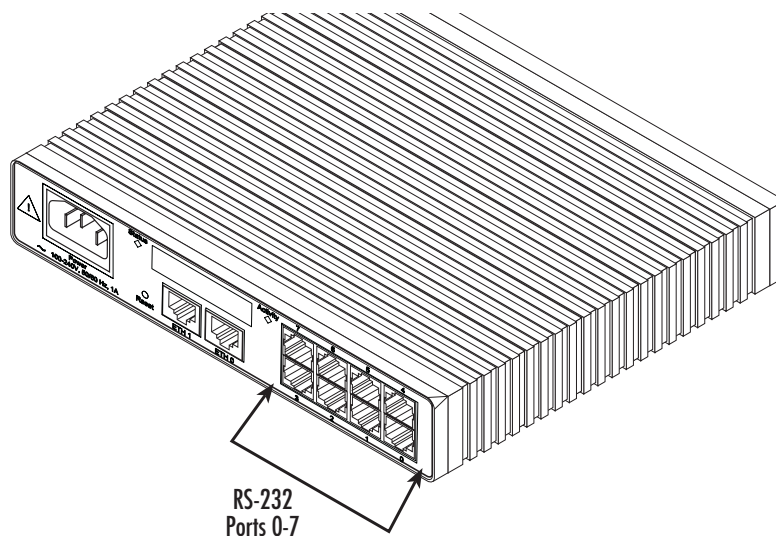

Figure 5. Connecting the RS-232 ports

Connecting the 10/100Base-T Ethernet LAN and WAN cables

The Model 3034/3038 has automatic MDX (auto-crossover) detection and configuration on all Ethernet ports. Any of the ports can be connected to a host or hub/switch with a straight-through or cross-over wired cable.

1. Connect to the subscriber port of the broadband access modem (Cable, WLL) to *ETH 0/0*.
2. Connect port *ETH 0/1* to your LAN.

For details on the Ethernet port pinout and cables, refer to [Appendix C, “Cabling”](#) on page 49 and [Appendix D, “Port pin-outs”](#) on page 52.

Connecting the Composite port

Models with a V.35 port (3034/C and 3038/C).

1. Plug the V.35 WAN cable’s DB-25 end into the unit’s *Composite* connector.
2. Plug the other end of the cable into the V.35 device.

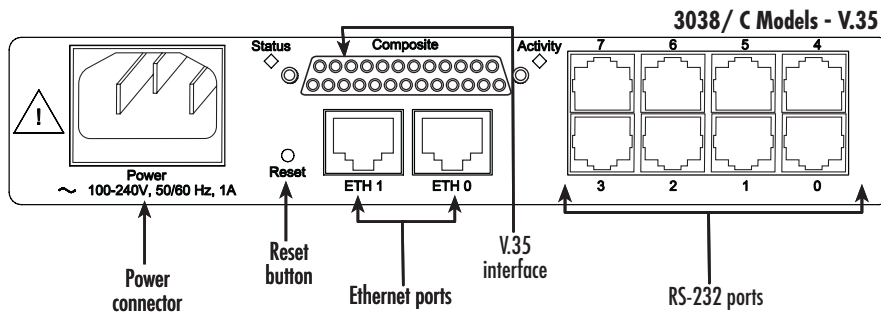

Figure 6. V.35 interface models

Models with an X.21 port (3034/D and 3038/D).

1. Plug the X.21 WAN cable’s DB-15 male end into the DB-15 connector (labeled *Composite*) on the 3034/3038.
2. Plug the other end of the cable into the X.21 device.

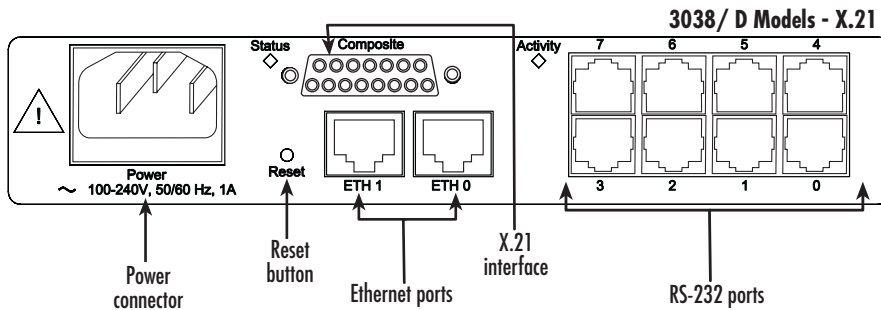

Figure 7. X.21 interface models

Models with a T1/E1 port and BNC Connectors (3034/K and 3038/K).

Connecting to the T1/E1 RJ-48C port

1. Obtain a twisted-pair cable with an RJ-48C plug connector at each end.
2. Plug one end of the cable into the RJ-48C port on the unit.
3. Plug the other end of the cable into the T1/E1 device.

Connecting to the dual BNC connectors

1. Obtain a coaxial cable with a BNC connector at each end.
2. Plug one end of the cable into the transmit socket (labeled *TX*) on the unit. Plug the other end of the cable into the receive port of the E1 device.
3. Plug one end of the cable into the receive socket (labeled *RX*) on the unit. Plug the other end of the cable into the transmit port of the E1 device..

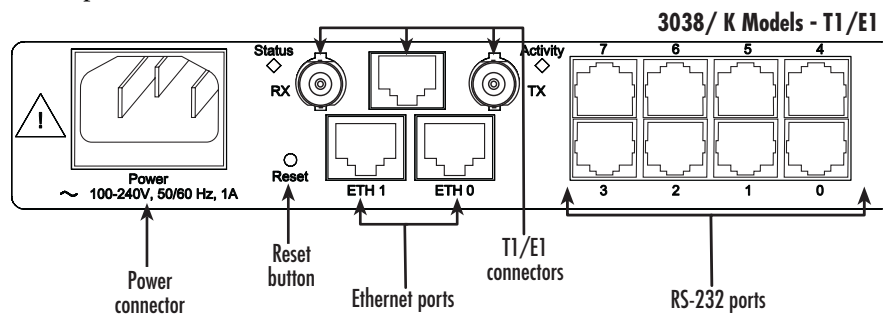

Figure 8. T1/E1 interface models

Connecting the power supply

The 3034/3038 has the option of an “[Internal AC Power Supply](#)” on page 27 or “[External AC Power Supply](#)” on page 27 , or an “[External DC Power Supply](#)” on page 28.

Internal AC Power Supply.

- Do not connect power to the AC Mains at this time.
- There are no user-serviceable parts in the power supply section of the Model 3034/3038. Contact Patton Electronics Technical support at (301)975-1007, via our web site at <http://www.patton.com>, or by e-mail at support@patton.com, for more information.
- The internal power supply automatically adjusts to accept an input voltage from 100 to 240 VAC (50/60 Hz). Verify that the proper voltage is present before plugging the power cord into the receptacle. Failure to do so could result in equipment damage.

1. Connect the AC power cord female plug directly to the AC connector.
2. Connect the AC power cord male plug to an AC power outlet (120–240 VAC).

The *Power* LED blinks as the unit is powering up. When the *Power* LED stops blinking and remains lit, the unit is ready for user configuration. (See [figure 3](#) on page 18).

External AC Power Supply.

- Do not connect power to the AC Mains at this time.
- The external power adapter shall be a listed Limited Power Source.
- There are no user-serviceable parts in the power supply section of the Model 3034/3038. Contact Patton Electronics Technical support at (301)975-1007, via our web site at <http://www.patton.com>, or by e-mail at support@patton.com, for more information.
- The 3034/3038 external power supply automatically adjusts to accept an input voltage from 100 to 240 VAC (50/60 Hz). Verify that the proper voltage is present before plugging the power cord into the receptacle. Failure to do so could result in equipment damage.

An LPS 120/240V AC to 5VDC adapter is supplied with the EUI version of the Model 3034/3038.

1. The female plug on the AC power cord plugs into the male AC connector on the adapter.
2. Connect the AC power cord male plug to an AC power outlet (120–240 VAC).

The *Power* LED blinks as the unit is powering up. When the *Power* LED stops blinking and remains lit, the unit is ready for user configuration. (See [figure 3](#) on page 18).

External DC Power Supply.

- Do not connect power to the DC Mains at this time.
- There are no user-serviceable parts in the power supply section of the Model 3034/3038. Contact Patton Electronics Technical support at (301)975-1007, via our web site at <http://www.patton.com>, or by e-mail at support@patton.com, for more information.

A 48VDC to 5VDC adapter is supplied with the E48 version of the Model 3034/3038.

1. The barrel power connector plugs into the barrel power supply jack on the unit.
2. The black and red leads connect to the DC source (nominal 48VDC).

The *Power* LED blinks as the unit is powering up. When the *Power* LED stops blinking and remains lit, the unit is ready for user configuration. (See [figure 3](#) on page 18).



Figure 9. Connecting DC Power to the 3034/3038 DC Power Supply

This chapter leads you through the basic steps to set up a new Model 3034/3038. Setting up a new Model 3034/3038 consists of the following main steps:

Note If you haven't already installed the Model 3034/3038, refer to chapter 3, "[Model 3034/3038 installation](#)" on page 21.

- Connecting the Model 3034/3038 to your laptop PC
- Configuring the desired IP address
- Connecting the Model 3034/3038 to the network

Chapter 4 **Initial configuration**

Chapter contents

Introduction	30
1. Connecting the Model 3034/3038 to your PC	30
Connecting and logging in via the Ethernet port	30
Connecting and logging in via the Console port	31
2. Configuring the desired IP address	31
Factory-default IP settings	31
Login	32
Changing the IP address	32
Saving the IP address	32
3. Connecting the Model 3034/3038 to the network	32

Introduction

This chapter leads you through the basic steps to set up a new Model 3034/3038. Setting up a new Model 3034/3038 consists of the following main steps:

Note If you haven't already installed the Model 3034/3038, refer to chapter 3, “Model 3034/3038 installation” on page 21.

- Connecting the Model 3034/3038 to your laptop PC
- Configuring the desired IP address
- Connecting the Model 3034/3038 to the network

1. Connecting the Model 3034/3038 to your PC

First the Model 3034/3038 must be connected to the mains power supply with the power cable (see “Connecting the power supply” on page 26). Wait until the *Power* LED stops blinking and stays lit constantly. Now the Model 3034/3038 is ready.



CAUTION

The interconnecting cables shall be acceptable for external use and shall be rated for the proper application with respect to voltage, current, anticipated temperature, flammability, and mechanical serviceability.

Connecting and logging in via the Ethernet port

The Model 3034/3038 Series is equipped with Auto-MDX Ethernet ports, so you can use straight-through cables for host or hub/switch connections (see figure 10).

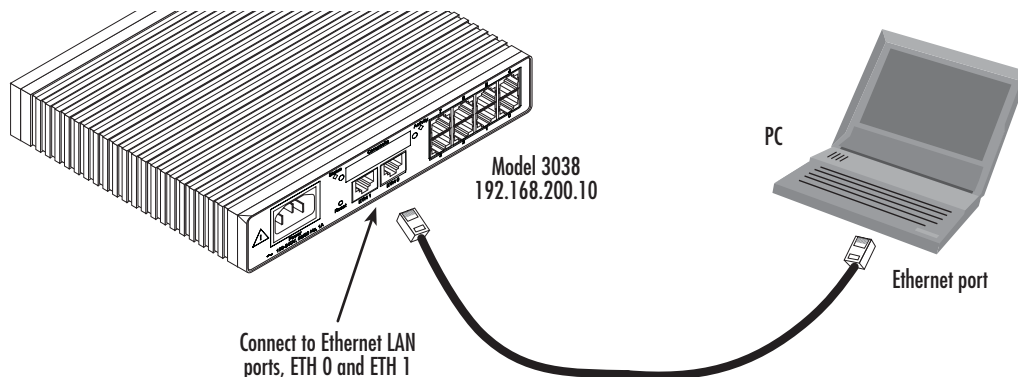

Figure 10. Connecting the Model 3034/3038 to your laptop PC via the Ethernet port

1. To access the configuration, connect a PC's Ethernet port to the unit's LAN port. Use the black Ethernet cable included with your 3034/3038 for this purpose.
2. Configure your PC's Ethernet port to be on the same subnet as the 3034/3038.
3. Open a Telnet connection to the default LAN IP address of the 3034/3038 (192.168.200.10). Log into the unit using the following:

```
login: admin
password:
```

Connecting and logging in via the Console port

1. To access the configuration via the console port, connect the DB9-RJ45 adapter to the DB-9 serial port on the PC or dumb terminal. Use the RJ45 straight-through cable between the adapter and the console port on the 3034/3038. (see Figure 11).

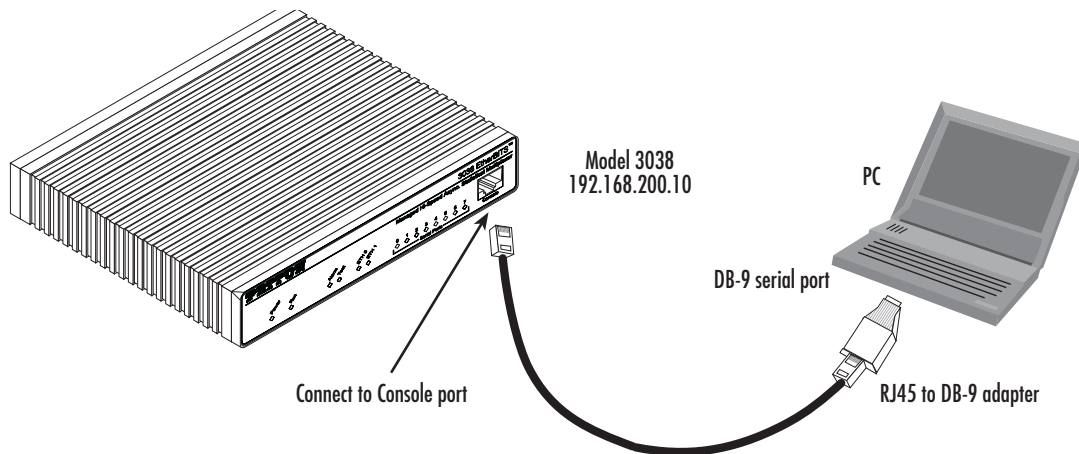

Figure 11. Connecting the Model 3034/3038 to your laptop PC via the console port

2. Do NOT connect the device to the Ethernet LAN now.
3. On the PC, start a HyperTerminal session at 19200 bps, 8 data bits, 1 stop bit, no flow control, and no parity.
4. Log into the unit using the following:

```
login: admin
password:
```

2. Configuring the desired IP address

Factory-default IP settings

The factory default configuration for the Ethernet interface IP addresses and network masks are listed in [table 6](#). Both Ethernet interfaces are activated upon power-up.

Table 6. Factory default IP address and network mask configuration

	IP Address	Network Mask
LAN interface Ethernet 0 (ETH 0)	192.168.200.10	255.255.255.0
LAN interface Ethernet 0 (ETH 0)	192.168.1.10	255.255.255.0
LAN interface Ethernet 0 (ETH 0)	DHCP	DHCP
LAN interface Ethernet 1 (ETH 1)	-	-

If these addresses match with those of your network, go to section “[3. Connecting the Model 3034/3038 to the network](#)” on page 32. Otherwise, refer to the following sections to change the addresses and network masks.

Login

To access the Model 3034/3038, start the ssh application. Type the default IP address for the router into the address field: **192.168.200.10**. Accessing your Model 3034/3038 via an ssh session displays the login screen. Type the factory default login: *admin* and password: *<blank>*.

```
login: admin
password:
Trinity#
```

Changing the IP address

You can set your IP address and network mask for the interface *ETH 0 (LAN)*. Within this example a network 192.168.1.1/24 address is assumed. The IP address in this example is set to *192.168.1.1* (you should set this the IP address given to you by your network provider).

```
Trinity# configure
Trinity[config]# interface ethernet eth0
Trinity[eth-eth0]# ip address 192.168.1.1 netmask 255.255.255.0
Trinity[eth-eth0]# no ip address 192.168.200.10
```

Note If you logged into the 3034/3038 with the IP address 192.168.200.10, you will need to reset your PC IP address to an address in the same network such as 192.168.1.5 and log back into the 3034/3038. Connectivity via the ssh session will be lost once the 192.168.200.10 address is removed.

Saving the IP address

To save the unit's IP address, login to the unit using *admin*, then use the following set of commands:

```
Trinity# [eth-eth0]# end
Trinity# copy running-config startup-config
Trinity#
```

3. Connecting the Model 3034/3038 to the network

In general, the Model 3034/3038 will connect to the network via the *LAN (ETH 0)* port. This enables the Model 3034/3038 to offer routing services to the PC hosts on *LAN (ETH 1)* port. The Model 3034/3038 Series is equipped with Auto-MDX Ethernet ports, so you can use straight-through or crossover cables for host or hub/switch connections.



The interconnecting cables shall be acceptable for external use and shall be rated for the proper application with respect to voltage, current, anticipated temperature, flammability, and mechanical serviceability.

You can check the connection with the ping command from the Model 3034/3038 to another host on the network: `Trinity#ping <IP Address of the host>`. If the WAN address is *not* set to DHCP, to ping a device outside your local LAN you must first configure the default gateway.

Note For more detailed configuration instructions, see the *Trinity Administrator's Reference Guide* located on the CD that shipped with your unit or online at www.patton.com.

Chapter 5 **RS-232 port configuration**

Chapter contents

Overview	34
Configuration Overview	34
Web Management Interface (WMI)	35
Port Configuration	35
Command Line Interface (CLI)	36

Overview

This chapter describes how to configure statistical multiplexer settings. Models 3034/3038 with the Trinity platform offer terminal ports on the back of the device.

Configuration Overview

Models 3034/3038 can act as a statistical multiplexer when configured in conjunction with another 3034/3038. When using two 3034/3038s as statistical multiplexers, one device must be configured as the master and one as the slave. Typically, the 3034/3038 installed at the remote site should be configured in slave mode, while the 3034/3038 installed at the local site should be configured in master mode.

In master mode, the IP address of the remote 3034/3038 must be specified and a TCP/UDP port number is optional. If the port number is not specified, the default value is used. For example, for serial interface 1, the default port is 30001.

In slave mode, the port is also optional but the port number used on the slave must match the port configured on the master. Like master mode, if the port number is not specified, the default value is used.

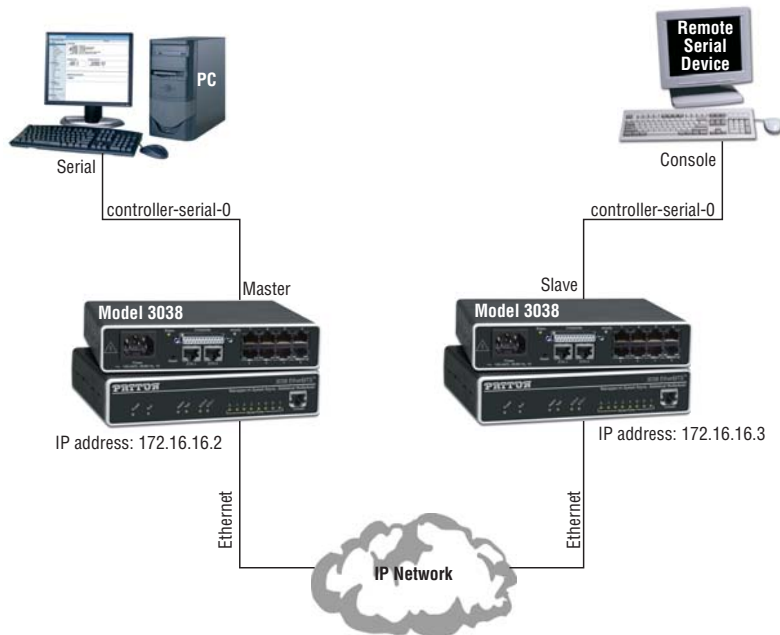

Figure 12. 3034/3038 networking diagram

In the figure above, an example configuration for the master and slave units is shown here for establishing a connection between port 0 of the master and slave units for reference:

Master 3034/3038	Slave 3034/3038
controller terminal 0	controller terminal 0
speed 9600	speed 9600
parity none	parity none
data 8	data 8
stop-bits 1	stop-bits 1
mode master 172.16.16.3 30000	mode slave 30000
no shutdown	no shutdown
exit	exit

Web Management Interface (WMI)

To access the statistical multiplexer main page, click on **Interface Configuration** > **Terminal** from the menu on the left of the screen.

Port	State
0	Disabled
1	Disabled
2	Disabled
3	Disabled
4	Disabled
5	Disabled

Figure 13. Terminal Configuration

The **Terminal Configuration** main page displays the list of terminal ports and the current state of the ports. 3034 Models have four terminal ports and 3038 models have 8 terminal ports.

Port Configuration

To configure a terminal port:

1. Click on the number of the port you would like to configure in the **Port** column on the Terminal Configuration main page.
2. The **Terminal Port Status** page displays. Click on the **Configuration** tab at the top of the page.
3. Check the **Enabled** box to turn on the terminal port.
4. Set the following fields:
 - **Datasize:** Set the data bits of the terminal port. Select an option from the range 5–8.
 - **Flow Control:** Set the flow control of the terminal port. Select **None**, **RTS/CTS**, or **XON/XOFF**.
 - **Parity:** Set the parity of the terminal port. Select **Even**, **Mark**, **None**, **Odd**, or **Space**.
 - **Speed:** Set the baud rate for the terminal port. Select an option from the range 50–230400.
 - **Stop Bits:** Set the baud rate for the terminal port. Select **1** or **2**.
 - **Mode:** Set the mode for the terminal port configuration. Select **master** or **slave**.
 - **Remote IP address:** Set the IP address of the slave 3034/3038.
 - **Port Number:** Set the Port Number to use (or <cr> for default).
 - **Allow-remote-control:** Set this to allow remote control of the port.
5. Click **Update** to save your settings.

Command Line Interface (CLI)

The following commands are used to configure the terminal interfaces:

Table 7. Stat Mux- CLI Commands

Step	Explanation
configure controller terminal <0-7>	Enter the serial controller configuration mode.
clear	Reset the statistics shown in the show command.
data {5,6,7,8}	Set the data bits of the terminal interface.
flow {none,rtcts,xonxoff}	Set the flow control of the terminal interface.
mode {none,master,slave}	Set the mode of the terminal interface. An interface can only operate in one mode at a time.
mode master <A.B.C.D> [<0-40000>] [allow-remote-control]	Enable master mode, configure remote IP address, and configure optional port number. If no port number is specified, the default port value is 30000 plus the number of the terminal interface (ie 30001 for terminal interface 1). Enable remote control of the port.
mode slave [<0-40000>]	Enable slave mode and configure optional port number.
parity {even, mark, none, odd, space}	Set the parity of the terminal interface.
show	Display the configuration and statistics for this interface.
[no] shutdown	Enables or disables the terminal interface.
speed <50-230400>	Set the baud rate of the terminal interface.
stop-bits {2,1.5, 1}	Set the baud rate of the terminal interface.
show cont terminal	Show configuration of all terminal interfaces

Example – show cont terminal command:

```

Port|Speed|Parity| Flow |Data Size |Stop Bits
0 | 9600| none | none | cs8 | one
1 | 9600| none | none | cs8 | one
2 |19200| even | none | cs8 | one
3 | 9600| none | none | cs8 | one
4 |19200| none | none | cs8 | one
5 |19200| none | none | cs8 | one
6 | 9600| none | none | cs8 | one
7 | 9600| none | none | cs8 | one

```

Chapter 6 **Sync Serial Configuration**

Chapter contents

Overview	38
Configuration Overview	38
Web Management Interface (WMI)	38
Command Line Interface (CLI)	39

Overview

This chapter describes how to configure the sync serial interface on the following models:

- Model 3034/C – V.35 interface
- Model 3034/D – X.21 interface
- Model 3038/C – V.35 interface
- Model 3038/D – X.21 interface

Configuration Overview

When using two 3038s as statistical multiplexers, the sync serial interface (labeled *Composite* on the unit–V.35 or X.21) allows connectivity across a WAN link.

To configure sync serial settings through the WMI, see the section “[Web Management Interface \(WMI\)](#)” on page 38.

To configure sync serial settings through the CLI, see the section “[Command Line Interface \(CLI\)](#)” on page 39.

Web Management Interface (WMI)

To access the statistical multiplexer main page, click on **Interface Configuration > Sync Serial** from the menu on the left of the screen.

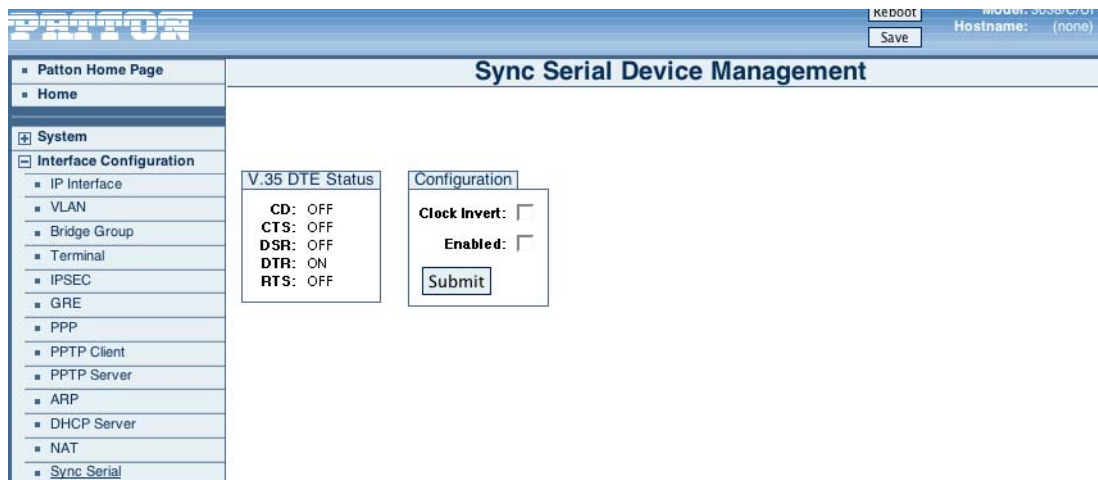

Figure 14. Sync Serial Device Management page

The **Sync Serial Device Management** main page displays the current state of the sync serial port (V.35 or X.21). You can also select to invert the clock signal and enable/disable the port. Click **Submit** to save your settings.

Command Line Interface (CLI)

Table 8. Stat Mux- CLI Commands

Step	Explanation
configure controller sync-serial	Enter the sync-serial interface configuration mode.
clock	Set the parameters.
clock invert	Invert the clock signal.
clock rate <4K-7168K>	Set the generated clock sample rate in the range from 4K to 7168K (DCE interface only).
[no] shutdown	Enable or disable the sync-serial interface.
status	Display the status and configuration of the sync-serial interface.
show controller sync-serial	Display the status and configuration of the sync-serial interface.

Example – show controller sync-serial command:

```
V.35 DTE Serial Device Status
CD:          OFF
CTS:         OFF
DSR:         OFF
DTR:         ON
RTS:         OFF
Clock Invert: False
Enabled:     False
```

Chapter 7 **Contacting Patton for assistance**

Chapter contents

- Introduction41
- Contact information41
 - Patton support headquarters in the USA41
 - Alternate Patton support for Europe, Middle East, and Africa (EMEA)41
- Warranty Service and Returned Merchandise Authorizations (RMAs)41
 - Warranty coverage41
 - Out-of-warranty service42
 - Returns for credit42
 - Return for credit policy42
 - RMA numbers42
 - Shipping instructions42

Introduction

This chapter contains the following information:

- “Contact information”—describes how to contact Patton technical support for assistance.
- “Warranty Service and Returned Merchandise Authorizations (RMAs)”—contains information about the warranty and obtaining a return merchandise authorization (RMA).

Contact information

Patton Electronics offers a wide array of free technical services. If you have questions about any of our other products we recommend you begin your search for answers by using our technical knowledge base. Here, we have gathered together many of the more commonly asked questions and compiled them into a searchable database to help you quickly solve your problems.

Patton support headquarters in the USA

- Online support: available at www.patton.com
- E-mail support: e-mail sent to support@patton.com will be answered within 1 business day
- Telephone support: standard telephone support is available five days a week—from 8:00 am to 5:00 pm EST (1300 to 2200 UTC/GMT)—by calling +1 (301) 975-1007
- Fax: +1 (253) 663-5693

Alternate Patton support for Europe, Middle East, and Africa (EMEA)

- Online support: available at www.patton-inalp.com
- E-mail support: e-mail sent to support@patton-inalp.com will be answered within 1 business day
- Telephone support: standard telephone support is available five days a week—from 8:00 am to 5:00 pm CET (0900 to 1800 UTC/GMT)—by calling +41 (0)31 985 25 55
- Fax: +41 (0)31 985 25 26

Warranty Service and Returned Merchandise Authorizations (RMAs)

Patton Electronics is an ISO-9001 certified manufacturer and our products are carefully tested before shipment. All of our products are backed by a comprehensive warranty program.

Note If you purchased your equipment from a Patton Electronics reseller, ask your reseller how you should proceed with warranty service. It is often more convenient for you to work with your local reseller to obtain a replacement. Patton services our products no matter how you acquired them.

Warranty coverage

Our products are under warranty to be free from defects, and we will, at our option, repair or replace the product should it fail within one year from the first date of shipment. Our warranty is limited to defects in workmanship or materials, and does not cover customer damage, lightning or power surge damage, abuse, or unauthorized modification.

Out-of-warranty service

Patton services what we sell, no matter how you acquired it, including malfunctioning products that are no longer under warranty. Our products have a flat fee for repairs. Units damaged by lightning or other catastrophes may require replacement.

Returns for credit

Customer satisfaction is important to us, therefore any product may be returned with authorization within 30 days from the shipment date for a full credit of the purchase price. If you have ordered the wrong equipment or you are dissatisfied in any way, please contact us to request an RMA number to accept your return. Patton is not responsible for equipment returned without a Return Authorization.

Return for credit policy

- Less than 30 days: No Charge. Your credit will be issued upon receipt and inspection of the equipment.
- 30 to 60 days: We will add a 20% restocking charge (crediting your account with 80% of the purchase price).
- Over 60 days: Products will be accepted for repairs only.

RMA numbers

RMA numbers are required for all product returns. You can obtain an RMA by doing one of the following:

- Completing a request on the RMA Request page in the *Support* section at **www.patton.com**
- By calling **+1 (301) 975-1007** and speaking to a Technical Support Engineer
- By sending an e-mail to **returns@patton.com**

All returned units must have the RMA number clearly visible on the outside of the shipping container. Please use the original packing material that the device came in or pack the unit securely to avoid damage during shipping.

Shipping instructions

The RMA number should be clearly visible on the address label. Our shipping address is as follows:

Patton Electronics Company

RMA#: xxxx

7622 Rickenbacker Dr.

Gaithersburg, MD 20879-4773 USA

Patton will ship the equipment back to you in the same manner you ship it to us. Patton will pay the return shipping costs.

Appendix A **Compliance information**

Chapter contents

Compliance	44
EMC	44
Safety	44
PSTN Regulatory	44
Radio and TV Interference	44
FCC Part 68 (ACTA) Statement	44
Industry Canada Notice	45
CE Declaration of Conformity	45
Authorized European Representative	45

Compliance

EMC

- FCC Part 15, Class A
- EN55022, Class A
- EN55024

Safety

- UL 60950-1/CSA C22.2 N0. 60950-1
- IEC/EN60950-1
- AS/NZS 60950-1

PSTN Regulatory

- FCC Part 68
- CS-03
- TBR 12 & 13 (E1)
- AS/ACIF S016:2001 (E1)

Radio and TV Interference

The Model 3034/3038 router generates and uses radio frequency energy, and if not installed and used properly—that is, in strict accordance with the manufacturer’s instructions—may cause interference to radio and television reception. The Model 3034/3038 router have been tested and found to comply with the limits for a Class A computing device in accordance with specifications in Subpart B of Part 15 of FCC rules, which are designed to provide reasonable protection from such interference in a commercial installation. However, there is no guarantee that interference will not occur in a particular installation. If the Model 3034/3038 router does cause interference to radio or television reception, which can be determined by disconnecting the unit, the user is encouraged to try to correct the interference by one or more of the following measures: moving the computing equipment away from the receiver, re-orienting the receiving antenna and/or plugging the receiving equipment into a different AC outlet (such that the computing equipment and receiver are on different branches).

FCC Part 68 (ACTA) Statement

This equipment complies with Part 68 of FCC rules and the requirements adopted by ACTA. On the bottom side of this equipment is a label that contains—among other information—a product identifier in the format US: AAAEQ##TXXXX. If requested, this number must be provided to the telephone company.

The method used to connect this equipment to the premises wiring and telephone network must comply with the applicable FCC Part 68 rules and requirements adopted by the ACTA.

If this equipment causes harm to the telephone network, the telephone company will notify you in advance that temporary discontinuance of service may be required. But if advance notice isn’t practical, the telephone company will notify the customer as soon as possible. Also, you will be advised of your right to file a complaint with the FCC if you believe it is necessary.

The telephone company may make changes in its facilities, equipment, operations or procedures that could affect the operation of the equipment. If this happens the telephone company will provide advance notice in order for you to make necessary modifications to maintain uninterrupted service.

If trouble is experienced with this equipment, for repair or warranty information, please contact our company. If the equipment is causing harm to the telephone network, the telephone company may request that you disconnect the equipment until the problem is resolved.

Connection to party line service is subject to state tariffs. Contact the state public utility commission, public service commission or corporation commission for information.

Industry Canada Notice

This equipment meets the applicable Industry Canada Terminal Equipment Technical Specifications. This is confirmed by the registration number. The abbreviation, IC, before the registration number signifies that registration was performed based on a Declaration of Conformity indicating that Industry Canada technical specifications were met. It does not imply that Industry Canada approved the equipment.

This Declaration of Conformity means that the equipment meets certain telecommunications network protective, operational and safety requirements. The Department does not guarantee the equipment will operate to the user's satisfaction. Before installing this equipment, users should ensure that it is permissible to be connected to the facilities of the local telecommunications company. The equipment must also be installed using an acceptable method of connection. In some cases, the company's inside wiring associated with a single line individual service may be extended by means of a certified connector assembly (telephone extension cord). The customer should be aware that compliance with the above condition may not prevent degradation of service in some situations. Repairs to some certified equipment should be made by an authorized maintenance facility designated by the supplier. Any repairs or alterations made by the user to this equipment, or equipment malfunctions, may give the telecommunications company cause to request the user to disconnect the equipment. Users should ensure for their own protection that the ground connections of the power utility, telephone lines and internal metallic water pipe system, are connected together. This protection may be particularly important in rural areas.

CE Declaration of Conformity

This equipment conforms to the requirements of Council Directive 1999/5/EC on the approximation of the laws of the member states relating to Radio and Telecommunication Terminal Equipment and the mutual recognition of their conformity.

The safety advice in the documentation accompanying this product shall be obeyed. The conformity to the above directive is indicated by CE sign on the device.

The signed Declaration of Conformity can be downloaded at www.patton.com/certifications.

Authorized European Representative

D R M Green

European Compliance Services Limited.

Oakdene House, Oak Road

Watchfield, Swindon, Wilts SN6 8TD, UK

Appendix B **Specifications**

Chapter contents

RS-232 Ports	47
Composite Ports	47
Ethernet Ports	47
Serial Console Port	47
Commands	47
IP Services	48
IP Connectivity	48
Operating Environment	48
System	48

RS-232 Ports

- Serial Asynchronous start-stop
- Number of Ports: 8 ports (3038); 4 ports (3034)
- Max Aggregate Speed: 2Mbps
- Interface: CCITT V.24 (EIA-561) on 8-pin RJ-45F
- Data Communication Speed: Selectable 50bps-230.4kbps
- Data Format: Selectable 5,6,7, or 8 bits; 1, 1.5 or 2 stop bits, odd, even, or no parity
- Flow Control: Software selectable (XON/XOFF) or hardware (RTS/CTS) in both directions
- Break Propagation: Transparent
- EIA signal propagation: Status of local DTR signal can be propagated to the remote end
- Echo: Character echo can be selectively enabled for each terminal port

Composite Ports

- Auto-sensing 10/100BaseTX MDI-X Ethernet/V.35/X.21/ T1/E1
- Error detection and correction: 16-bit CRC-CCITT with ARQ (automatic re-transmission on error)
- Speed: Selectable, serial up to 1.2Mbps-2Mbps, Ethernet auto detect-10/100
- Interface: DB25, V.35; DB15, X.21
- Data Encoding: NRZ or NRZI
- Clock: Receive clock: external; Transmit clock: selectable as internal or external

Ethernet Ports

- Interface Auto-sensing 10/100BaseTX MDI-X on RJ-45

Serial Console Port

- Serial Communication Protocol: Asynchronous start-top
- Serial Speed: 19200 bps
- Serial Data format: 8 data bits, 1 stop bit, no parity

Commands

- Set/modify/view parameters
- View status
- Store parameters in non-volatile memory
- Copy parameters between ports
- Provide local/remote loop backs on port

- Establish connection between supervisory and terminal ports
- Obtain statistic reports
- Unit reset; individual port reset
- Remote supervisory access
- Enable/Disable remote access

IP Services

- IPv4
- RIPv1 and v2 (RFC 1058 and 2453)
- ICMP redirect (RFC 792); packet fragmentation
- DiffServ/ToS set or queue per header bits
- Packet policing discards excess traffic
- 802.1p/Q VLAN support with 4096 IDs

IP Connectivity

- X.21/V.35 (Frame Relay (8PVCs); RFC1490,FRF.12 fragmentation; LMI, Q993D, ANSI 617D, Gang of Four; PPP,PAP,CHAP,LCP,IPCP; T1/E1 (ITU-T G.703,ANSI T1.403; AMI, B8ZS, HDB3)
- TCPRAW
- UDP
- Telnet
- DHCP
- NAT

Operating Environment

Temperature: 0–40°C

Humidity: 5–80% (non condensing)

System

- CPU Motorola MPC859 @ 50 MHz
- Memory 16MB SDRAM/4MB Flash
- Power: 100–240 VAC (50/60 Hz)
- Power dissipation: 8-10W

Appendix C **Cabling**

Chapter contents

Introduction	50
Console	50
Ethernet	51

Introduction

This section provides information on the cables used to connect the Model 3034/3038 and the interface cards to the existing network infrastructure and to third party products.

Console

The Model 3034/3038 can be connected to a serial terminal over its serial console port, as depicted in figure 15.



The interconnecting cables shall be acceptable for external use and shall be rated for the proper application with respect to voltage, current, anticipated temperature, flammability, and mechanical serviceability.

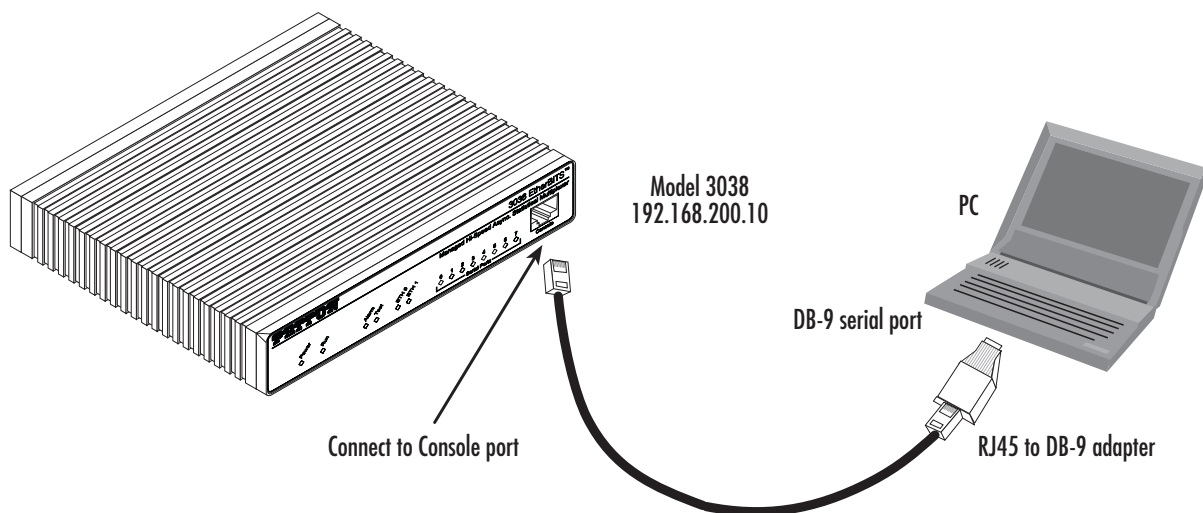

Figure 15. Connecting a serial terminal

Note See section “Console port” on page 53 for console port pin-outs.

Ethernet

Ethernet devices (10Base-T/100Base-T/1000Base-T) are connected to the Model 3034/3038 over a cable with RJ-45 plugs. All Ethernet ports on the Model 3034/3038 are Auto-MDX use any straight or crossover cable to connect to hubs, switches, PCs or other devices.



The interconnecting cables shall be acceptable for external use and shall be rated for the proper application with respect to voltage, current, anticipated temperature, flammability, and mechanical serviceability.

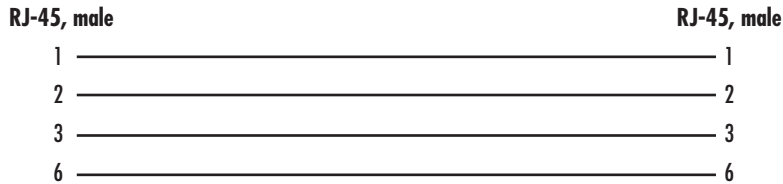
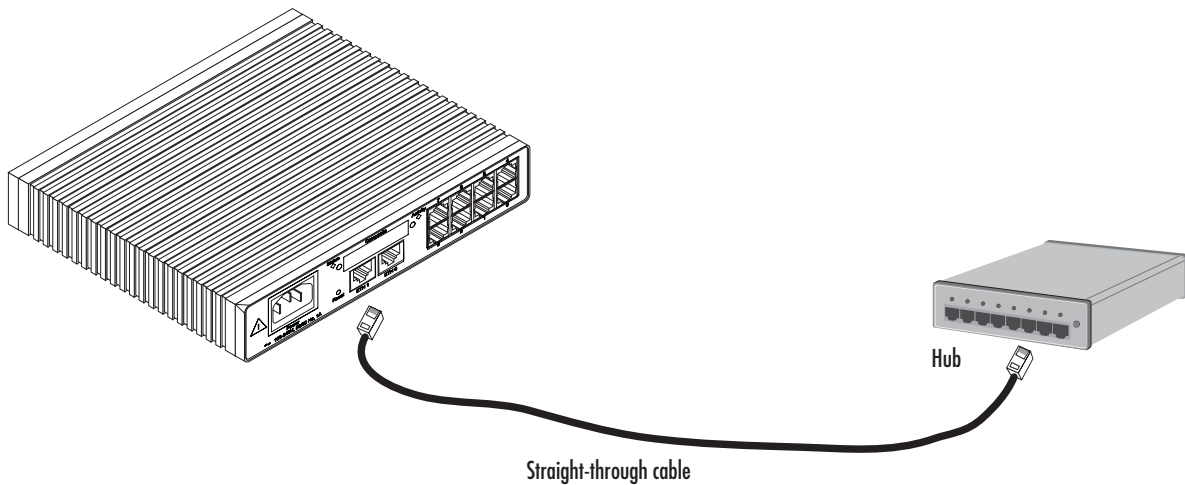

Note: Other pins are not used.

Figure 16. Typical Ethernet straight-through cable diagram for 10/100Base-T

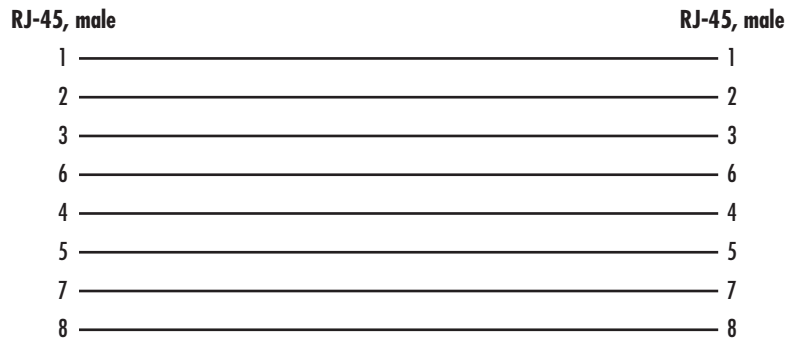

Appendix D **Port pin-outs**

Chapter contents

Introduction	53
Console port.....	53
Ethernet	54
V.35 (DB-25 connector)	54
X.21 (DB-15 connector).....	55
T1/E1.....	55
RS-232	55

Introduction

This section provides pin-out information for the ports of the Model 3034/3038.

Console port

Configuration settings: 9600 bps, 8 bits, no parity, 1 stop bit, no flow control

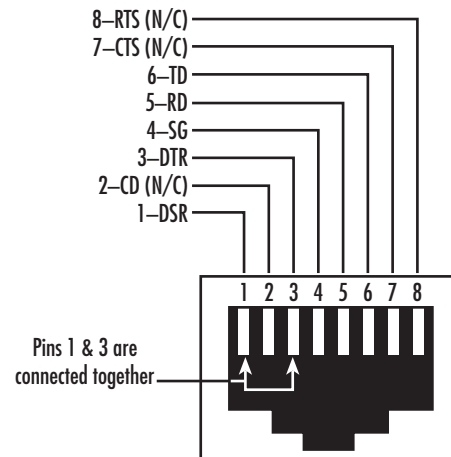

Figure 17. EIA-561 (RJ-45 8-pin) port

Note *N/C* means no internal electrical connection.

Ethernet

Table 9. RJ45 socket 10/100Base-T

Pin	Signal
1	TX+
2	TX-
3	RX+
6	RX-

Note Pins not listed are not used.

Table 10. RJ45 socket 1000Base-T

Pin	Signal
1	TRD0+
2	TRD0-
3	TRD1+
6	TRD1-
4	TRD2+
5	TRD2-
7	TRD3+
8	TRD3-

V.35 (DB-25 connector)

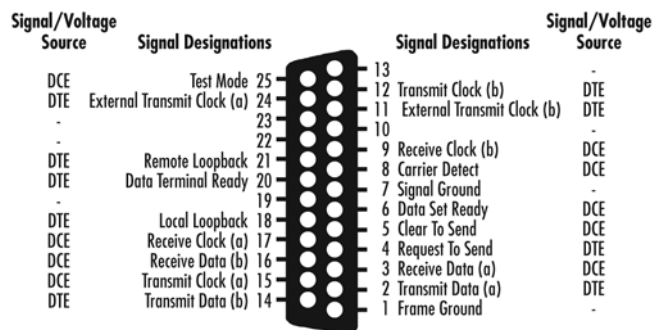

X.21 (DB-15 connector)

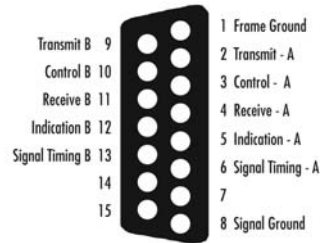

T1/E1

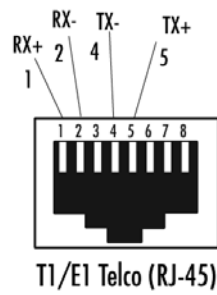

RS-232

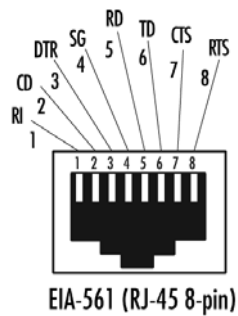

Appendix E **End user license agreement**

Chapter contents

- End User License Agreement57
 - 1. Definitions57
 - 2. Title57
 - 3. Term57
 - 4. Grant of License57
 - 5. Warranty57
 - 6. Termination58
 - 7. Other licenses58

End User License Agreement

By opening this package, operating the Designated Equipment or downloading the Program(s) electronically, the End User agrees to the following conditions:

1. Definitions

- A) *Effective Date* shall mean the earliest date of purchase or download of a product containing the Patton Electronics Company Program(s) or the Program(s) themselves.
- B) *Program(s)* shall mean all software, software documentation, source code, object code, or executable code.
- C) *End User* shall mean the person or organization which has valid title to the Designated Equipment.
- D) *Designated Equipment* shall mean the hardware on which the Program(s) have been designed and provided to operate by Patton Electronics Company.

2. Title

Title to the Program(s), all copies of the Program(s), all patent rights, copyrights, trade secrets and proprietary information in the Program(s), worldwide, remains with Patton Electronics Company or its licensors.

3. Term

The term of this Agreement is from the Effective Date until title of the Designated Equipment is transferred by End User or unless the license is terminated earlier as defined in section “6. Termination” on page 58.

4. Grant of License

- A) During the term of this Agreement, Patton Electronics Company grants a personal, non-transferable, non-assignable and non-exclusive license to the End User to use the Program(s) only with the Designated Equipment at a site owned or leased by the End User.
- B) The End User may copy licensed Program(s) as necessary for backup purposes only for use with the Designated Equipment that was first purchased or used or its temporary or permanent replacement.
- C) The End User is prohibited from disassembling; decompiling, reverse-engineering or otherwise attempting to discover or disclose the Program(s), source code, methods or concepts embodied in the Program(s) or having the same done by another party.
- D) Should End User transfer title of the Designated Equipment to a third party after entering into this license agreement, End User is obligated to inform the third party in writing that a separate End User License Agreement from Patton Electronics Company is required to operate the Designated Equipment.

5. Warranty

The Program(s) are provided *as is* without warranty of any kind. Patton Electronics Company and its licensors disclaim all warranties, either express or implied, including but not limited to the implied warranties of merchantability, fitness for a particular purpose or non-infringement. In no event shall Patton Electronics Company or its licensors be liable for any damages whatsoever (including, without limitation, damages for loss of business profits, business interruption, loss of business information, or other pecuniary loss) arising out of the use of or inability to use the Program(s), even if Patton Electronics Company has been advised of the possibility of such damages. Because some states do not allow the exclusion or limitation of liability for consequential or incidental damages, the above limitation may not apply to you.

If the Program(s) are acquired by or on behalf of a unit or agency of the United States Government, the Government agrees that such Program(s) are *commercial computer software* or *computer software documentation* and that, absent a written agreement to the contrary, the Government's rights with respect to such Program(s) are limited by the terms of this Agreement, pursuant to Federal Acquisition Regulations 12.212(a) and/or DEARS 227.7202-1(a) and/or sub-paragraphs (a) through (d) of the "Commercial Computer Software - Restricted Rights" clause at 48 C.F.R. 52.227-19 of the Federal Acquisition Regulations as applicable.

6. Termination

- A) The End User may terminate this agreement by returning the Designated Equipment and destroying all copies of the licensed Program(s).
- B) Patton Electronics Company may terminate this Agreement should End User violate any of the provisions of section "4. Grant of License" on page 57.
- C) Upon termination for A or B above or the end of the Term, End User is required to destroy all copies of the licensed Program(s)

7. Other licenses

The Program may be subject to licenses extended by third parties. Accordingly, Patton Electronics Company licenses the Programs subject to the terms and conditions dictated by third parties. Third party software identified to the Programs includes:

- A routing license is included at no charge.
- MGCP capabilities will require the purchase of an additional license.
- The LGPL (Lesser General Public License) open source license distributed to you pursuant to the LGPL license terms (<http://www.gnu.org/licenses/lgpl.html>).
- RedBoot (Red Hat Embedded Debug and Bootstrap) embedded system debug/bootstrap environment from Red Hat distributed to you pursuant to the eCos license terms (<http://ecos.sourceware.org/license-overview.html>) and GNU General Public License (GPL) terms (<http://www.gnu.org/copyleft/gpl.html>). Source code is available upon request.