

USER MANUAL

MODEL 3P-MF and 3P-MF9

DB-25 and DB-9 In-Line Power Supply Adapters



PATTON
Electronics Co.



An ISO-9001
Certified Company

Part# 07M3PMF9 Rev. C
Doc# 056020U
Revised 1/23/08

SALES OFFICE
(301) 975-1000
TECHNICAL SUPPORT
(301) 975-1007

TABLE OF CONTENTS

1.0	Warranty Information	2
1.1	Radio and TV Interference.....	2
1.2	CE Notice.....	2
1.3	Service.....	3
2.0	General Information.....	4
2.1	Features.....	4
2.2	Description.....	4
3.0	Installation.....	5
A	Patton Model 3P-MF & 3P-MF9 Specifications.....	6
A.1	Transmission Format	6
B	Patton Model 3P-MF & 3P-MF9 Pin Assignments.....	7
C	Patton Model 3P-MF Block Diagram	8

1.0 WARRANTY INFORMATION

Patton Electronics warrants all Model 3P-MF Series components to be free from defects, and will—at our option—repair or replace the product should it fail within one year from the first date of shipment.

This warranty is limited to defects in workmanship or materials, and does not cover customer damage, abuse or unauthorized modification. If this product fails or does not perform as warranted, your sole recourse shall be repair or replacement as described above. Under no condition shall **Patton Electronics** be liable for any damages incurred by the use of this product. These damages include, but are not limited to, the following: lost profits, lost savings and incidental or consequential damages arising from the use of or inability to use this product. **Patton Electronics** specifically disclaims all other warranties, expressed or implied, and the installation or use of this product shall be deemed an acceptance of these terms by the user.

1.1 RADIO AND TV INTERFERENCE

The Models 3P-MF and 3P-MF9 generate and use radio frequency energy, and if not installed and used properly—that is, in strict accordance with the manufacturer's instructions—may cause interference to radio and television reception. The Models 3P-MF and 3P-MF9 have been tested and found to comply with the limits for a Class A computing device in accordance with the specifications in Subpart J of Part 15 of FCC rules, which are designed to provide reasonable protection from such interference in a commercial installation. However, there is no guarantee that interference will not occur in a particular installation. If the Model 3P-MF or 3P-MF9 do cause interference to radio or television reception, which can be determined by turning the power off or disconnecting the RS-232 interface, the user is encouraged to try to correct the interference by one of the following measures: moving the computing equipment away from the receiver, re-orienting the receiving antenna and/or plugging the receiving equipment into a different AC outlet (such that the computing equipment and receiver are on different branches).

1.2 CE NOTICE

The CE symbol on your Patton Electronics equipment indicates that it is in compliance with the Electromagnetic Compatibility (EMC) directive and the Low Voltage Directive (LVD) of the Union European (EU). A Certificate of Compliance is available by contacting Patton Technical Support.

1.3 SERVICE

All warranty and non-warranty repairs must be returned freight prepaid and insured to Patton Electronics. All returns must have a Return Materials Authorization number on the outside of the shipping container. This number may be obtained from Patton Electronics Technical Service at **(301) 975-1007, <http://www.patton.com>, or support@patton.com.**

Note Packages received without an RMA number will not be accepted.

Patton Electronics' technical staff is also available to answer any questions that might arise concerning the installation or use of your Model 3P-MF Series product. Technical Service hours: **8AM to 5PM EST, Monday through Friday.**

2.0 GENERAL INFORMATION

Thank you for your purchase of this Patton Electronics product. This product has been thoroughly inspected and tested and is warranted for One Year parts and labor. If any questions or problems arise during installation or use of this product, please do not hesitate to contact Patton Electronics Technical Support at **(301) 975-1007**.

2.1 FEATURES

- Solves low power interface problems
- Provides power to any Patton self-powered short-range modem
- Supplies 9 VDC to pin 9 (DB-25 and DB-9)
- DB-25 male to DB-25 female connectors (Model 3P-MF)
- DB-9 male to DB-25 female connectors (Model 3P-MF9)
- LED indicator shows power status
- 120 or 230 VAC versions available
- Very thin case (0.7 in./1.8 cm) for closely spaced computer ports
- Nothing to configure—*just plug it in!*

2.2 DESCRIPTION

The Model 3P-MF Series power supply adapters let you use any Patton self powered short haul with an *underpowered* EIA-232 or EIA-574 interface. Many laptops, notebooks and PC cards on the market supply interface that's well below the specifications of the actual standard. The Models 3P-MF (DB-25 connectors) and 3P-MF9 (DB-9 connectors) can easily bridge that gap. Special versions also available.

Model 3P-MF is equipped with DB-25 connectors on each end; Model 3P-MF9 has DB-9 connectors. Each provides 9VDC to Patton's interface powered short hauls on pin 9. And both 120 VAC and 230 VAC wall-mount adapter versions are available.

3.0 INSTALLATION

Patton's Model 3P-MF Series are easy to install and should give you years of trouble-free service. Here are a few simple instructions to help you get things hooked up right. If you have any questions, please contact Patton Electronics Technical Support at (301)975-1007.

1. Disconnect the short haul modem from the low-power EIA-232 device.
2. Connect Model 3P-MF/3P-MF9 into the DB-25/DB-9 connector of the short haul modem.
3. Connect the other end of the 3P-MF/3P-MF9 into the EIA-232 device. The application should look similar to the diagram in Figure 1.

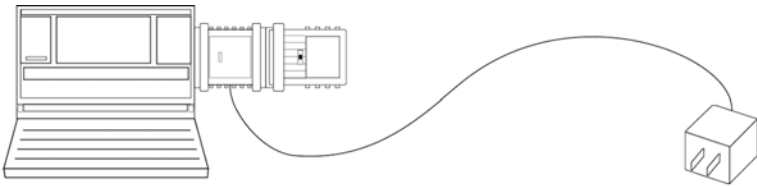

Figure 1. Connecting a Model 3P-MF

4. Plug the wall-adapter into the AC wall jack.
5. Connect the twisted pair line connection between short haul modems as described in the short haul modem user manual (see Figure 2,).

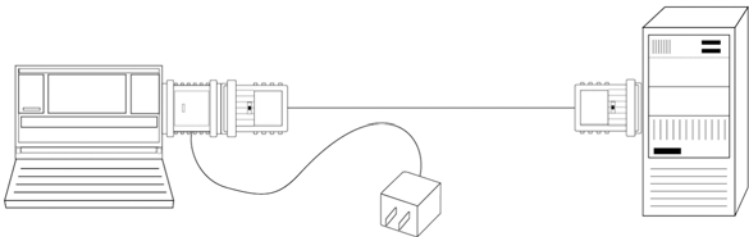

Figure 2. Powering up a Self-Powered Short Haul Modem with a Model 3P-MF

APPENDIX A
PATTON MODEL 3P-MF & 3P-MF9 SPECIFICATIONS

A.1 TRANSMISSION FORMAT

Asynchronous

A.2 ELECTRICAL INTERFACE

- Model 3P-MF: EIA-232
- Model 3P-MF9: EIA-574

A.3 DATA RATE

Transparent to Data Rate

A.4 DTE/DCE CONNECTION

Either a male or female DB-25

A.5 CONNECTORS

- Model 3P-MF: DB-25M and DB-25F
- Model 3P-MF9P: DB-9M and DB-9F

A.6 POWER SUPPLY

120 or 230 VAC wall mount adapter supplies 9 VDC

A.7 MAX. POWER OUTPUT

+9 VDC $\pm 5\%$ at 100mA (approx 945 mW)

A.8 SIZE

- Model 3P-MF9: 2.7 x 1.2 x 0.7 in. (6.9 x 3.0 x 1.8 cm)
- Model 3P-MF: 2.2 x 2.1 x 0.7 in. (5.6 x 5.3 x 1.8 cm)

A.9 COMPLIANCE INFORMATION

- FCC Part 15, Class A
- UL/CSA (120VDC Wall Mount)
- EN55022 Class A (Emissions)
- EN50082-1 (Immunity)
- 89/336/EEC (Declaration of Conformity—Wall Mount)
- 73/23/EEC (Declaration of Conformity)

APPENDIX B PATTON MODEL 3P-MF & 3P-MF9 PIN ASSIGNMENTS

Model 3P-MF DB-25 Interface	
SIGNAL/PIN#	SIGNAL/PIN#
Secondary Transmit Data - 14	1 - (FG) Frame Ground
Transmit Clock - 15	2 - (TD) Transmit Data
Secondary Receive Clock - 16	3 - (RD) Receive Data
Receiver Clock - 17	4 - (RTS) Request to Send
Local Loopback - 18	5 - (CTS) Clear to Send
Secondary Request to Send - 19	6 - (DSR) Data Set Ready
Data Terminal Ready - 20	7 - (SG) Signal Ground
Remote Loopback - 21	8 - (CD) Carrier Detect
Ring Indicator - 22	9 - (DCV+) DC Test Voltage*
Data Signal Rate Selector - 23	10 - (DCV-) DC Test Voltage
Transmit Clock - 24	11 - Unassigned
Test Mode - 25	12 - Secondary Rcvd Line
	13 - Secondary Clear to Send

* **Note** Model 3P-MF applies power to pin 9 (DCV+) only. All other signals are passed through unmodified from end-to-end. Signal names are provided here to more closely represent the EIA-232 standard (see Appendix C on page 8).

Model 3P-MF9 DB-9 Interface	
SIGNAL/PIN#	SIGNAL/PIN#
Data Set Ready (DSR) - 6	1 - (CD) Carrier Detect
Ready to Send (RTS) - 7	2 - (RD) Receive Data
Clear to Send (CTS) - 8	3 - (TD) Transmit Data
*DC Test Voltage (DCV+) - 9	4 - (DTR) Data Terminal Ready
	5 - (SG/FG) Signal Ground/ Frame Ground

* **Note** Model 3P-MF9 applies power to pin 9 (DCV+) only. All other signals are passed through unmodified from end-to-end. Signal names are provided here to more closely represent the EIA-232 standard (see Appendix C on page 8).

APPENDIX C PATTON MODEL 3P-MF BLOCK DIAGRAM

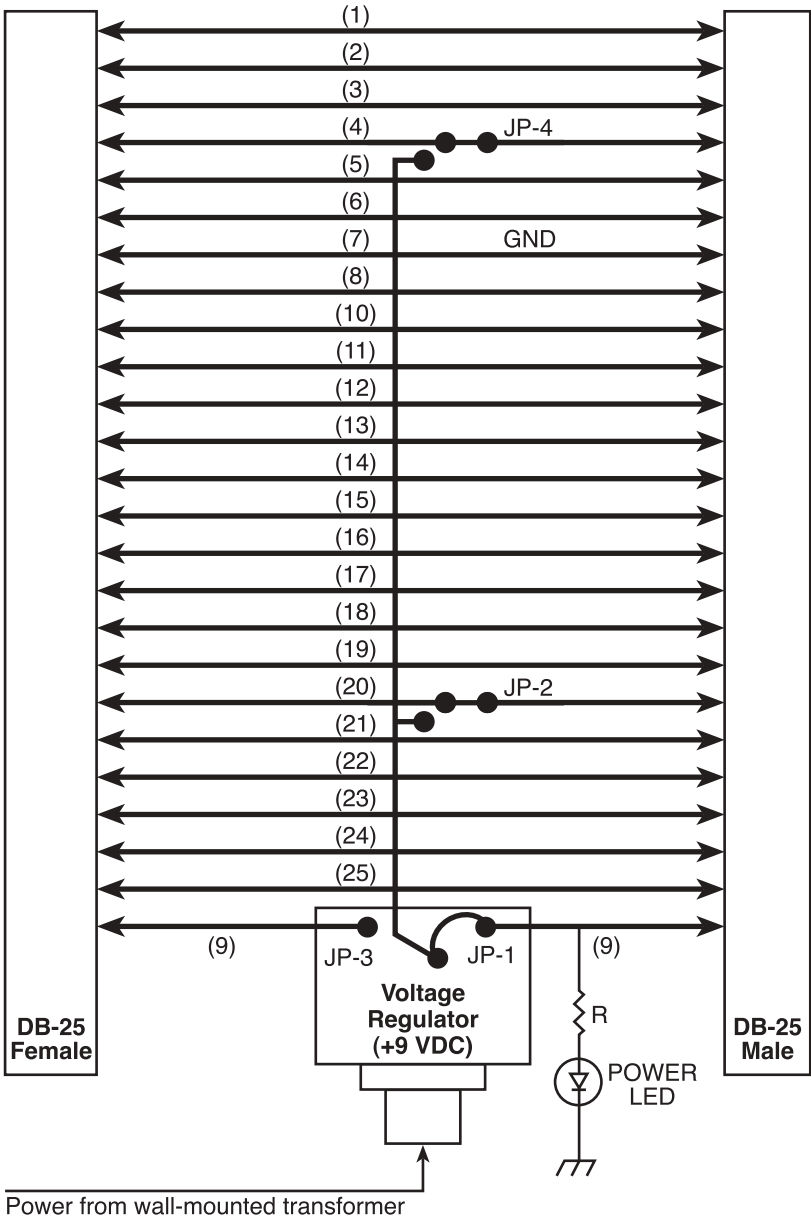

APPENDIX C - (CONTINUED)
PATTON MODEL 3P-MF9 BLOCK DIAGRAM

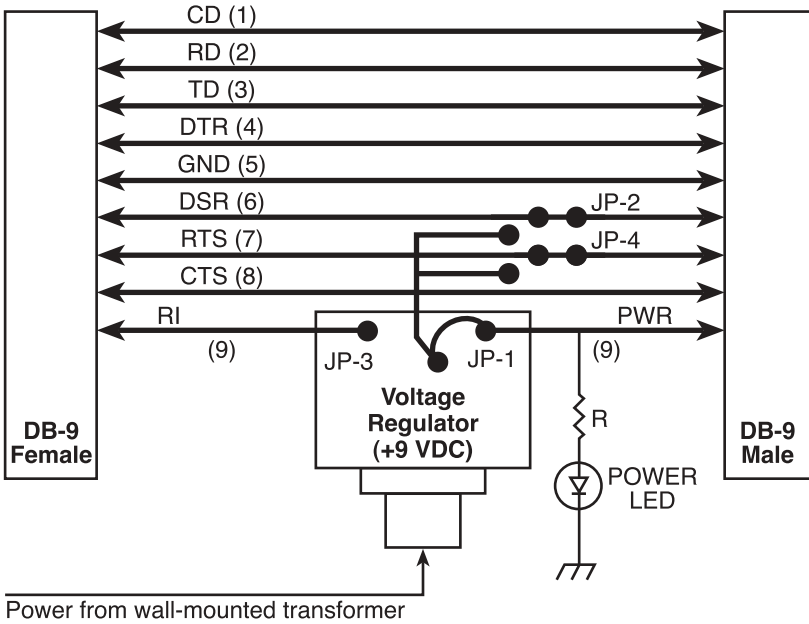

Power can be provided through pin 9 (default setting), DSR, or RTS by changing jumper settings (see Table 1).

Table 1: Power Output Strap Selection

Jumper	Description
JP-1	Connect 9 VDC to male connector (Default setting)
JP-2	Connect 9 VDC to DSR
JP-3	Connect pin 9 of male and female connectors
JP-4	Connect 9 VDC to RTS

Dear Valued Customer,

Thank you for purchasing Patton Electronics products! We do appreciate your business. I trust that you find this user manual helpful.

We manufacture one of the widest selections of data communications products in the world including CSU/DSU's, network termination units, powered and self-powered short range modems, fiber optic modems, interface converters, baluns, electronic data switches, data-line surge protectors, multiplexers, transceivers, hubs, print servers and much more. We produce these products at our Gaithersburg, MD, USA, facility, and can custom manufacture products for your unique needs.

We would like to hear from you. Please contact us in any of the following ways to tell us how you like this product and how we can meet your product needs today and in the future.

Web:	http://www.patton.com
Sales E-mail:	sales@patton.com
Support E-mail:	support@patton.com
Phone - Sales	(301) 975-1000
Phone - Support	(301) 975-1007
Fax:	(301) 869-9293
Mail:	Patton Electronics Company 7622 Rickenbacker Drive Gaithersburg, MD 20879 USA

We are committed to a quality product at a quality price. Patton Electronics is ISO 9001 certified. We meet and exceed the highest standards in the industry (CE, UL, etc.).

It is our business to serve you. If you are not satisfied with any aspect of this product or the service provided from Patton Electronics or its distributors, please let us know.

Thank you.

Burton A. Patton
Vice President

P.S. Please tell us where you purchased this product:
