

EnviroNET™ 2100 Series Ethernet Extenders

User Manual



Important—This is a Class A device and is intended for use in an industrial environment. It is not intended nor approved for use in a residential environment.

Important—This device is NOT intended nor approved for connection to the PSTN. It is intended only for connection to customer premise equipment.

Sales Office: +1 (301) 975-1000
Technical Support: +1 (301) 975-1007
E-mail: support@patton.com
WWW: www.patton.com

Document Number: 06401U2-001, Rev. A
Part Number: 07MEN2100-UM
Revised: **October 22, 2007**

Patton Electronics Company, Inc.

7622 Rickenbacker Drive
Gaithersburg, MD 20879 USA
Tel: +1 (301) 975-1000
Fax: +1 (301) 869-9293
Support: +1 (301) 975-1007
Web: www.patton.com
E-mail: support@patton.com

Trademark Statement

Trademark names and copyrights are the registered trademarks or copyright names of the respective owners and owned by them. Other brand names, product names or trade names appearing in this document are the properties and registered trademarks of their respective owners. All names mentioned herewith are served for identification purpose only.

Copyright © 2007, Patton Electronics Company. All rights reserved.

The information in this manual is subject to change without notice for continuous improvement in the product. All rights are reserved. The manufacturer assumes no responsibility for any inaccuracies that may contain in this document, and makes no commitment to update or to keep current the information contain in this manual.

No part of this manual may be reproduced, copied, translated or transmitted, in whole or in part, in any form or by any means without prior written permission of the factory.

Contents

Contents	3
About this guide	5
Audience.....	5
Structure.....	5
Precautions	6
Safety when working with electricity	7
1 General Information	8
Overview	9
Features	9
Types of EnviroNET models.....	10
Interface Options.....	11
2 Installing the EnviroNET	12
Before you begin.....	13
What you will need	13
Opening the case	13
About the Hardware.....	14
PC Board	15
AC/DC Power Supply	16
Interface Board	16
Wiring the power	17
Running the power cable through the gland	17
Connecting the power cable wires to the EnviroNET	18
Wiring the terminal block	19
Running the twisted pair wires through the gland	19
Connecting the twisted pair wires to the EnviroNET	20
Configuring the EnviroNET	21
Mounting the EnviroNET.....	21
Wall mount	21
Pole mount	21
3 Configuring the EnviroNET	22
Configuring the EnviroNET	23
EnviroNET Model 2172	23
Configuring DIP Switch S2	24
Switch 1: Symmetric/Asymmetric Operation	25
Switches 2 and 3: Data Rate	25
Switches 4, 5 and 6: Ethernet Configuration	25
Switch 7: Ethernet Shutdown	26
Switch 8: Remote Configuration	26
EnviroNET Model 2168	27

Configuring DIP Switch S1	28
Switch 1: Ethernet Auto Sense	29
Switches 2, 3, and 4: Data Rate	29
Switches 5, 6, 7, and 8: Reserved	30
Other Models	30
4 Operating the EnviroNET	31
Powering up the EnviroNET	32
LEDs (ET and EC models only)	32
ET models	32
EC models	32
About Thermal Operation (ET Models only)	33
Operating the EnviroNET	33
5 Contacting Patton for assistance	34
Introduction	35
Contact information	35
Patton support headquarters in the USA	35
Alternate Patton support for Europe, Middle East, and Africa (EMEA)	35
Warranty Service and Returned Merchandise Authorizations (RMAs)	35
Warranty coverage	35
Out-of-warranty service	36
Returns for credit	36
Return for credit policy	36
RMA numbers	36
Shipping instructions	36
A Compliance	37
Compliance	38
EMC Compliance:	38
Safety Compliance:	38
PSTN Regulatory Compliance:	38
Radio and TV Interference (FCC Part 15)	38
CE Declaration of Conformity	38
Authorized European Representative	39
B Specifications	40
EnviroNET Model 2156	41
EnviroNET Model 2157	42
EnviroNET Model 2168	42
EnviroNET Model 2172	43

About this guide

This guide describes the EnviroNET Ethernet Extenders Series hardware, installation and basic configuration.

Audience

This guide is intended for the following users:

- Operators
- Installers
- Maintenance technicians

Structure

This guide contains the following chapters and appendices:

- [Chapter 1](#) on page 8 provides basic information about EnviroNET features and interface options
- [Chapter 2](#) on page 12 contains instructions on installing, wiring, and mounting the EnviroNET
- [Chapter 3](#) on page 22 provides information on configuring specific models
- [Chapter 4](#) on page 31 provides information about operating the EnviroNET
- [Chapter 5](#) on page 34 contains information on contacting Patton technical support for assistance
- [Appendix A](#) on page 37 provides compliance information
- [Appendix B](#) on page 40 contains specifications for the EnviroNET

For best results, read the contents of this guide *before* you install the EnviroNET.

Precautions

Notes, cautions, and warnings, which have the following meanings, are used throughout this guide to help you become aware of potential problems. **Warnings** are intended to prevent safety hazards that could result in personal injury. **Cautions** are intended to prevent situations that could result in property damage or impaired functioning.

Note A note presents additional information or interesting sidelights.



The alert symbol and IMPORTANT heading calls attention to important information.



CAUTION

The alert symbol and CAUTION heading indicate a potential hazard. Strictly follow the instructions to avoid property damage.



CAUTION

The shock hazard symbol and CAUTION heading indicate a potential electric shock hazard. Strictly follow the instructions to avoid property damage caused by electric shock.



WARNING

The alert symbol and WARNING heading indicate a potential safety hazard. Strictly follow the warning instructions to avoid personal injury.



WARNING

The shock hazard symbol and WARNING heading indicate a potential electric shock hazard. Strictly follow the warning instructions to avoid injury caused by electric shock.

Safety when working with electricity



- This device is to be installed only by qualified service personnel. It contains no user serviceable parts, and shall be returned to Patton Electronics for repairs, or repaired by qualified service personnel.
- Hazardous network voltages are present in WAN ports regardless of whether power to the unit is ON or OFF. To avoid electric shock, use caution when near WAN ports. When detaching the cables, detach the end away from the device first.
- Do not work on the system or connect or disconnect cables during periods of lightning activity.
- This device is NOT intended nor approved for connection to the PSTN. It is intended only for connection to customer premise equipment.



In accordance with the requirements of council directive 2002/96/EC on Waste of Electrical and Electronic Equipment (WEEE), ensure that at end-of-life you separate this product from other waste and scrap and deliver to the WEEE collection system in your country for recycling..

Chapter 1 **General Information**

Chapter contents

Overview	9
Features	9
Types of EnviroNET models	10
Interface Options.....	11

Overview

EnviroNET™ Ethernet Extenders provide transparent extension of your 10/100 Ethernet LANs at distances up to 8 km over a single twisted pair or line rates up to 50 Mbps! EnviroNET Ethernet Extenders operate at line rates from 192 kbps to 50 Mbps depending on the model selected.

EnviroNET™ Ethernet Extenders are housed in a NEMA 4 enclosure and operate in extreme temperatures, ranging from -40 to 85°C. EnviroNET Ethernet Extenders are the ideal solution for extending or providing Ethernet terminations to locations where harsh environmental elements such as heating, cooling, dust, and moisture cannot be controlled.

Features

EnviroNET Ethernet Extenders offer these features:

- **Ethernet Extension**—Extends 10/100Base-TX Ethernet at distances up to 8km over 2-wire 24 AWG unconditioned lines.
- **Extended Temperature** -40 to 85°C—Operates in environments that do not have heating or cooling options.
- **NEMA 4 Case**—Protection against elements such as dirt, rain, sleet, snow, dust, and the external formation of ice on the enclosure.
- **Auto-sensing Full-Duplex Ethernet**—Auto 10 or 100Base-TX and full or half-duplex Ethernet operation.
- **Transparent LAN Bridging**—Passes higher layer protocols and supports 802.1Q VLAN tagging.

The Patton EnviroNET Ethernet Extender offers a reliable and robust solutions for connecting peered 10/100Base-T Ethernet LANs; reaching remote PCs and equipment; or delivering last-mile ISP services—at line rates up to 50 Mbps! Patton's EnviroNET allows the Ethernet Extenders to operate under harsh temperatures (-40 to 85°C and -40 to 185°F) and resist various environmental elements such as dust, rain, snow, sleet, etc. Just co-locate an EnviroNET Ethernet Extender at any outdoor data acquisition location and pair it up with an equivalent Patton Ethernet Extender inside the building.

The EnviroNET is targeted for harsh industrial and outdoor applications. It is the pairing of standard Patton products into environmentally compatible enclosures to form a complete solution.

The enclosure is NEMA 4/IP-65 rated, which means that it offers protection against dirt, rain, sleet, snow, dust, and ice. The EnviroNET enclosure includes a sealed door, gasket cable management, and internal electronics for temperature control.

Types of EnviroNET models

The EnviroNET Ethernet Extender comes in three different model configurations: Extended, Hardened, and Controlled.

- **Extended (ET)**
 - Temperature from -40°C to 85°C (-40°F to 185°F)
 - Has a heater and a fan
 - Has 2 LEDs, Power and Temperature Control Indicator
- **Hardened (EH)**
 - Temperature from 0°C to 50°C (32°F to 122°F)
 - Does **not** have a fan or heater
 - Does **not** have LEDs
- **Controlled (EC)**
 - Temperature from 0°C to 85°C (32°F to 185°F)
 - Has a fan
 - Has 2 LEDs, Power and Temperature Control Indicator



Figure 1. EnviroNET Ethernet Extension Application

Interface Options

The EnviroNET Ethernet Extender can be made with different models from the Patton CopperLink Ethernet Extender product line. The EnviroNET Ethernet Extender models and features are listed in [table 1](#).

Table 1. EnviroNET Ethernet Extender Models and Features

Model	Temperature	Case Rating	Media Type	Max Line Rate	Max Distance
ET2172	-40 to 85°C -40 to 185°F	NEMA 4	2-Wire Twisted Pair	50 Mbps	2.1 km (1.3 miles)
EH2172	0 to 50°C 32 to 185°F	NEMA 4	2-Wire Twisted Pair	50 Mbps	2.1 km (1.3 miles)
EC2172	0 to 50°C 32 to 122°F	NEMA 4	2-Wire Twisted Pair	50 Mbps	2.1 km (1.3 miles)
ET2168	-40 to 85°C -40 to 185°F	NEMA 4	2-Wire Twisted Pair	16 Mbps	1.2 km (4,000 feet)
EH2168	0 to 50°C 32 to 185°F	NEMA 4	2-Wire Twisted Pair	16 Mbps	1.2 km (4,000 feet)
EC2168	0 to 50°C 32 to 122°F	NEMA 4	2-Wire Twisted Pair	16 Mbps	1.2 km (4,000 feet)
ET2157	-40 to 85°C -40 to 185°F	NEMA 4	2-Wire Twisted Pair	4.6 Mbps	8 km (5 miles)
EH2157	0 to 50°C 32 to 185°F	NEMA 4	2-Wire Twisted Pair	4.6 Mbps	8 km (5 miles)
EC2157	0 to 50°C 32 to 122°F	NEMA 4	2-Wire Twisted Pair	4.6 Mbps	8 km (5 miles)
ET2156	-40 to 85°C -40 to 185°F	NEMA 4	2-Wire Twisted Pair	2.3 Mbps	8 km (5 miles)
EH2156	0 to 50°C 32 to 185°F	NEMA 4	2-Wire Twisted Pair	2.3 Mbps	8 km (5 miles)
EC2156	0 to 50°C 32 to 122°F	NEMA 4	2-Wire Twisted Pair	2.3 Mbps	8 km (5 miles)

Note For more information about the specific CopperLink model that comes with your EnviroNET, see Appendix B, “[Specifications](#)” on page 40.

Chapter 2 **Installing the EnviroNET**

Chapter contents

- Before you begin.....13
 - What you will need13
 - Opening the case13
- About the Hardware.....14
 - PC Board15
 - AC/DC Power Supply16
 - Interface Board16
- Wiring the power17
 - Running the power cable through the gland17
 - Connecting the power cable wires to the EnviroNET18
- Wiring the terminal block19
 - Running the twisted pair wires through the gland19
 - Connecting the twisted pair wires to the EnviroNET20
- Configuring the EnviroNET21
- Mounting the EnviroNET.....21
 - Wall mount21
 - Pole mount21

Before you begin...

Before you can use the EnviroNET, you must first wire the power cable, wire the terminal block, and configure the unit.

Note You should complete the wiring and configuration of the EnviroNET before you mount the unit.

What you will need

The following components are **included**:

- EnviroNET unit, including PC board, power supply, and interface board

You **will need** the following components (**not included**):

- Flat-tip (large-bladed) screwdriver
- Crescent® (adjustable) wrench
- Desired length of power cable
- Desired length of CAT5 (twisted pair) cable
- 4 bolts for mounting (A mounting kit can be purchased separately).

Opening the case

To open the EnviroNET case (Figure 2):

1. Take a flat tip (large-bladed) screwdriver and insert it into the slot on a lock on the front of the case.
2. Turn the screwdriver counter-clockwise to unlock that lock.
3. Repeat Steps 1-2 for the other lock on the front of the case.
4. Lift the case door gently.

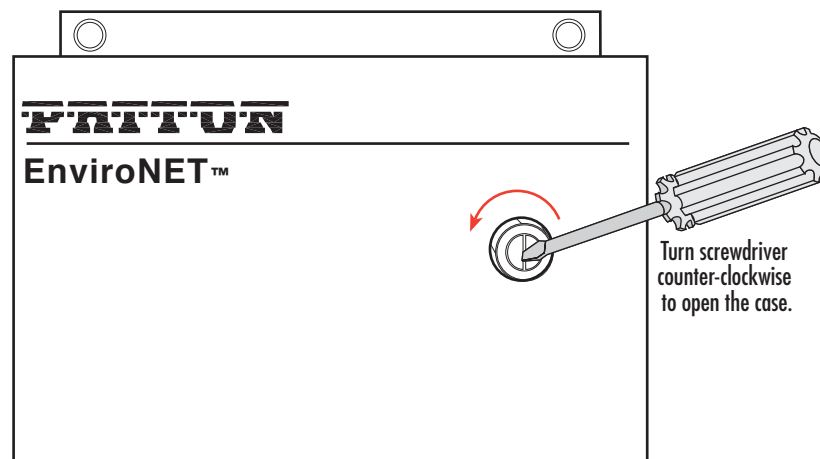

Figure 2. Opening the EnviroNET case

Note If you are unsure about the location or nature of the EnviroNET components, refer to the following section, “About the Hardware” on page 14, *before* you begin connecting cables and wiring the EnviroNET.

About the Hardware

This section offers information about hardware components that come with the EnviroNET, including the PC board, the AC/DC power supply, and the interface board.

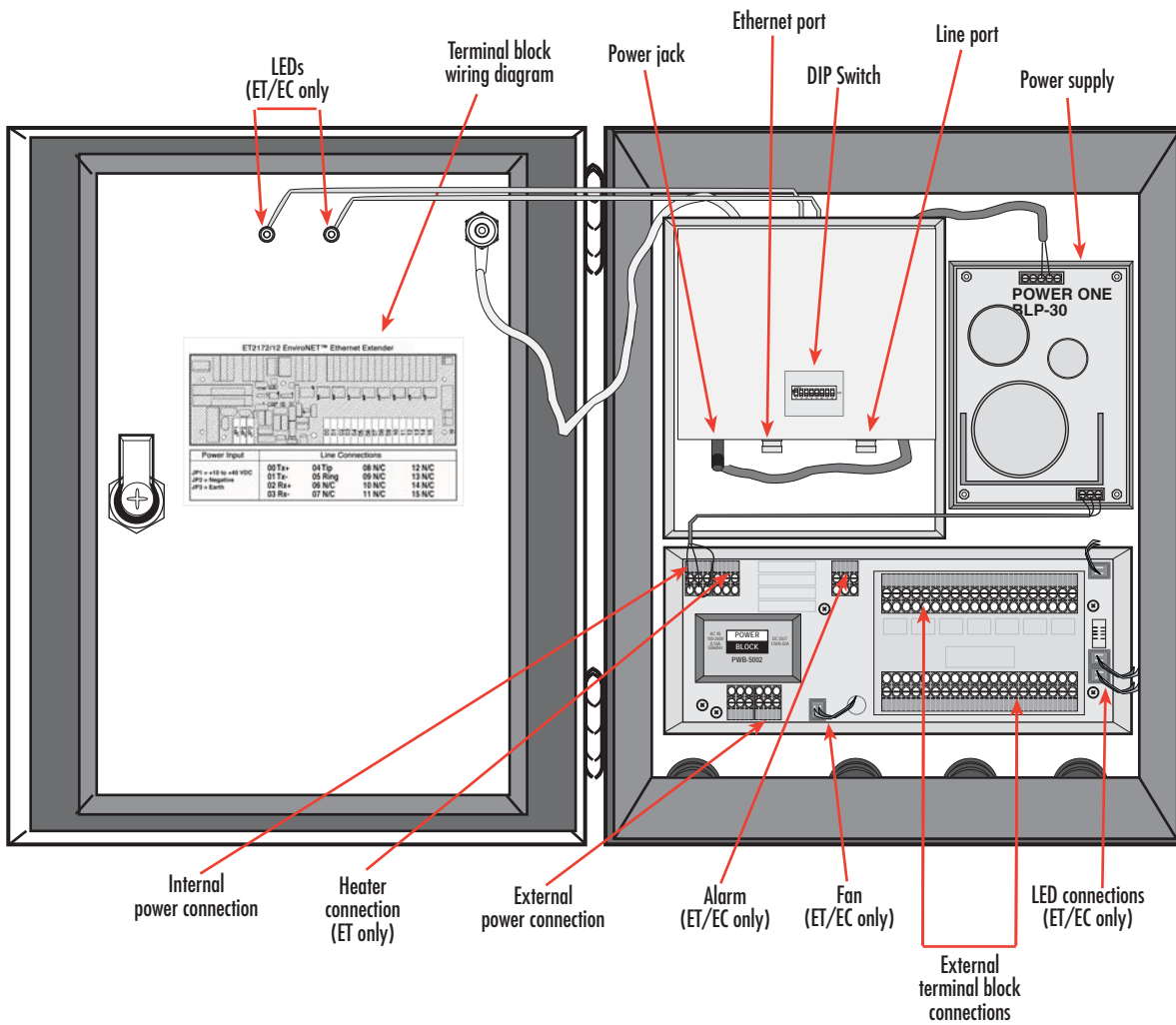

Figure 3. Diagram of EnviroNET components (Models 2168 and 2172)

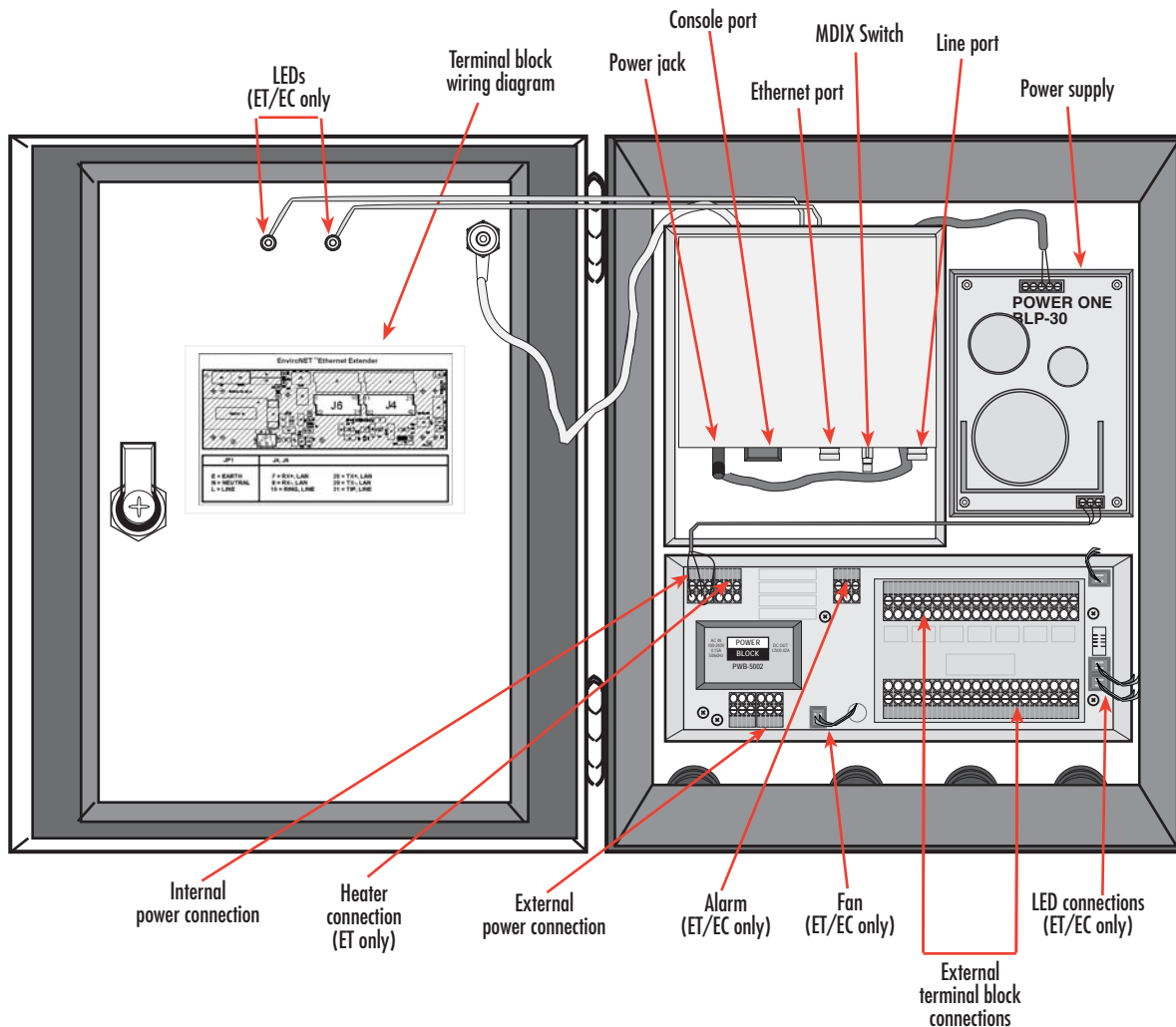

Figure 4. Diagram of EnviroNET components (Models 2156 and 2157)

PC Board

The PC Board contains the following connections:

- User-configurable Dip switches (S1 or S2)
- Line port
- Ethernet port
- Power jack

These connections are wired internally by the factory, but you will still need to wire the external connections on the terminal block for the PC board connections to work. (See “Wiring the terminal block” on page 19).

AC/DC Power Supply

The AC/DC power supply is installed internally by the factory. However, you will need to wire the power cable externally for the EnviroNET to have power. (See “Wiring the power” on page 17).

Interface Board

The Interface Board contains the following connections:

- Internal power
- External power
- Heater (ET model only)
- Temperature Control Indicator (ET and EC models only)
- Fan (ET and EC models only)
- External terminal block connections
- Internal terminal block connections
- Power and Temperature Control Indicator LED connections (ET and EC models only)

The user will need to wire the external terminal block connections and the external power connection only. The factory has already wired the internal power and internal terminal block connections, as well as the heater, temperature control indicator, fan, and LEDs.

Wiring the power

Inside the EnviroNET, the power cable is wired to the power supply, but it is not wired externally because different customers require different lengths of power cable for their specific EnviroNET environments. You will need to provide your desired length of power cable for the unit.

You should run the power cable through the brass gland that is placed to the far left on the bottom panel of the EnviroNET. (See [figure 5](#)). The steps to wiring the power include: running the power cable wires through the gland, and connecting the power cable wires to the EnviroNET unit.

Running the power cable through the gland

To run the power cable through the gland:

1. Locate the gland that the power cable should be run through. (See [figure 5](#)).

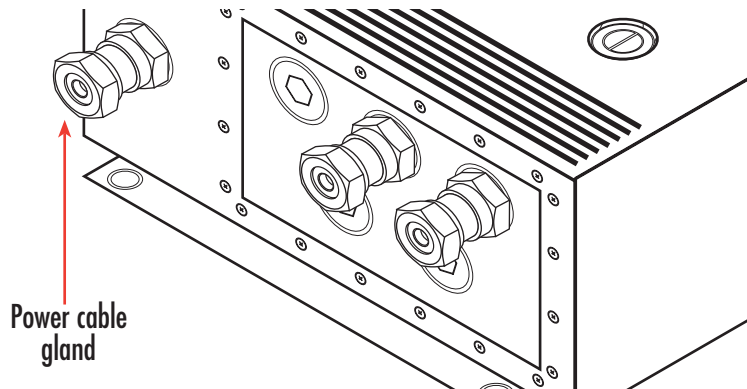

Figure 5. Gland designated for the power cable

2. You may unscrew the gland to allow more flexibility when threading the power cable wires. To unscrew the gland, either by hand or with a Crescent® (adjustable) wrench, turn the gland to the left until it is loosened.
3. Carefully thread the wires through the gland from the outside into the EnviroNET.

Note The brass glands on the bottom panel of the EnviroNET can properly seal cables with an outer diameter between 3mm and 8mm.

Connecting the power cable wires to the EnviroNET

To connect the power cable wires to the EnviroNET:

1. Run the power cable wires from outside of the EnviroNET through the unscrewed gland (on the far left) to the inside of the unit.
2. Connect the power cable wires to the external power connection block that is labeled, E N L, as described in [table 2](#). (Also, see [figure 6](#)).

Table 2. Power cable wires

Designated Slot	Power Wire (Color)
Earth (E)	Green
Neutral (N)	White
Line (L)	Black

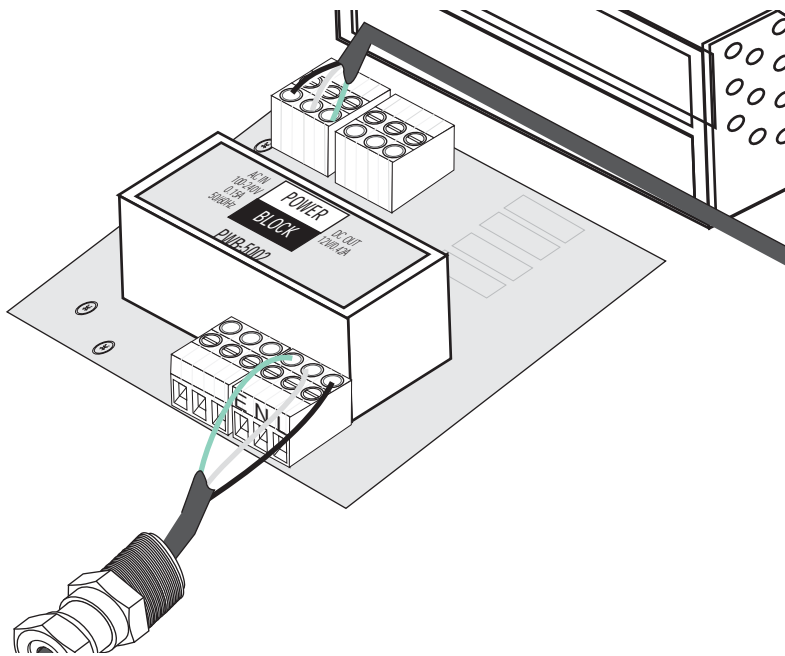

Figure 6. Connecting the power cable wires to the EnviroNET

3. Be sure to leave a little slack on the wires so that they are not stressed or pulled too tightly. Also, make sure that the power cable wires are secured tightly in the E N L block.
4. To ensure that the cables are properly secured in the gland, tighten the gland by turning the loose pieces all the way to the right using a Crescent® (adjustable) wrench.

Wiring the terminal block

Inside the EnviroNET, the terminal block is wired to the PC board, but it is not wired externally because different customers require different lengths of wire for their specific EnviroNET environments. You will need to provide your desired length of CAT5 (twisted pair) wires for the unit.

You should run the twisted pair wires through the brass glands that are placed on the right on the bottom panel of the EnviroNET. (See [figure 7](#)). The steps to wiring the terminal block include: running the twisted pair wires through the gland, and connecting the twisted pair wires to the EnviroNET unit.

Running the twisted pair wires through the gland

To run the twisted pair wires through the gland:

1. Locate the glands that the twisted pair wires should run through. (See [figure 7](#)).

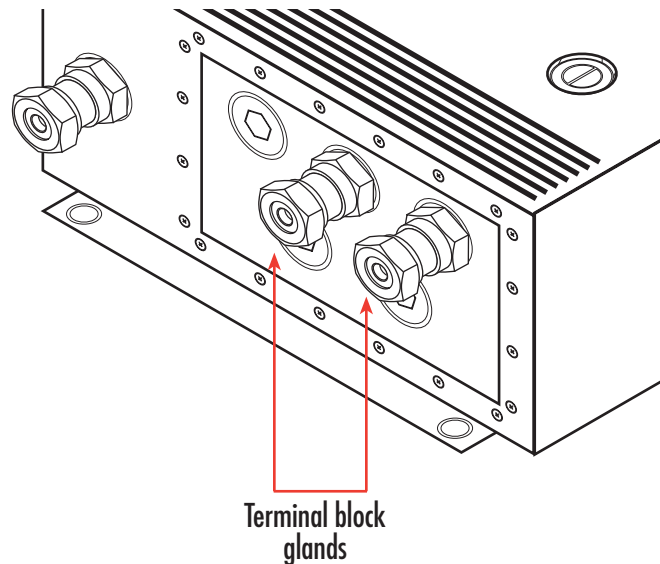

Figure 7. Glands designated for the terminal block

2. You may unscrew the gland to allow more flexibility when threading the wires. To unscrew the gland, either by hand or with a Crescent® (adjustable) wrench, turn the gland to the left until it is loosened.
3. Carefully thread the wires through the gland from the outside into the EnviroNET.

Note The brass glands on the bottom panel of the EnviroNET can properly seal cables with an outer diameter between 3mm and 8mm.

Connecting the twisted pair wires to the EnviroNET

To connect the twisted pair wires to the EnviroNET:

1. Run the twisted pair wires from outside of the EnviroNET through the unscrewed glands (on the right) to the inside of the unit.
2. Connect the appropriate wires to the appropriate slots in the terminal block. There should be one wire per gland. Follow the wiring diagram that is on the inside of the EnviroNET door (see figure 8).

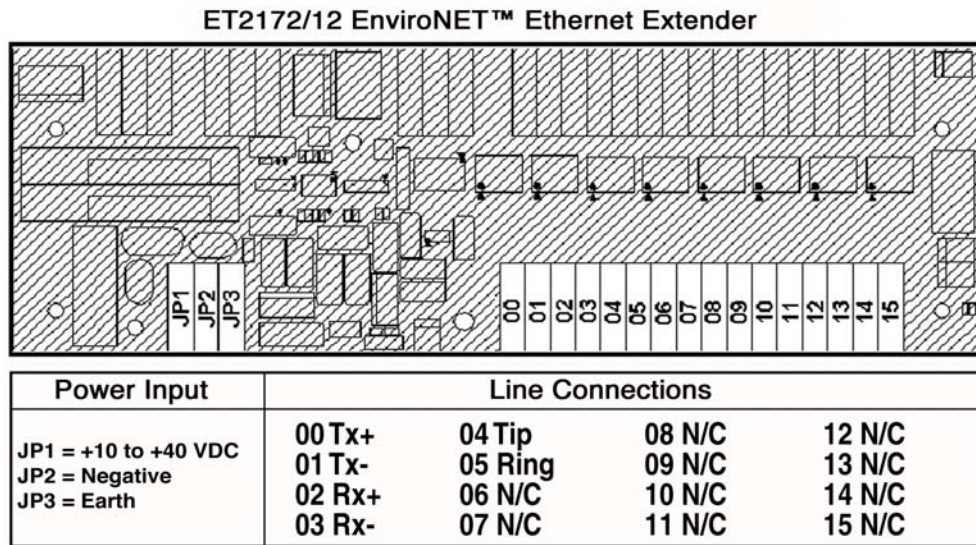

Figure 8. Terminal block diagram (Displayed on the inside of the EnviroNET door)

3. Be sure to leave a little slack on the wires so that they are not stressed or pulled too tightly. Also, make sure that the twisted pair wires are secured tightly in the terminal block.
4. To ensure that the cables are properly secured in the gland, tighten the gland by turning the loose pieces all the way to the right using a Crescent® (adjustable) wrench.

Note The black plugs for the brass glands on the bottom panel of the EnviroNET **should not** be removed.

Configuring the EnviroNET

You should configure the EnviroNET **before** you mount it.

For information on how to configure the EnviroNET, see Chapter 3, “Configuring the EnviroNET” on page 22.

Mounting the EnviroNET

The EnviroNET can be mounted in two ways: wall mount and pole mount.

Wall mount

The wall mount is the typical way that an EnviroNET can be mounted. You will need four bolts to mount the EnviroNET.

To mount the EnviroNET:

1. Make sure that the location where you chose to mount the EnviroNET is sturdy and can securely hold the unit.
2. Be sure that the door to the EnviroNET is securely closed and locked. To lock the case, close the door and use a flat-tip screwdriver to turn the locks to all the way to the right.
3. Mount the EnviroNET by securing the bolts through the holes on the EnviroNET to the wall panel.

Pole mount

The pole mount option is available by request. For information on how to mount the EnviroNET to a pole, refer to the *EnviroNET Pole Mount Quick Start Guide* that shipped with the pole mount kit.

Chapter 3 **Configuring the EnviroNET**

Chapter contents

Configuring the EnviroNET	23
EnviroNET Model 2172	23
Configuring DIP Switch S2	24
Switch 1: Symmetric/Asymmetric Operation	25
Switches 2 and 3: Data Rate	25
Switches 4, 5 and 6: Ethernet Configuration	25
Switch 7: Ethernet Shutdown	26
Switch 8: Remote Configuration	26
EnviroNET Model 2168	27
Configuring DIP Switch S1	28
Switch 1: Ethernet Auto Sense	29
Switches 2, 3, and 4: Data Rate	29
Switches 5, 6, 7, and 8: Reserved	30
Other Models	30

Configuring the EnviroNET

You can configure the EnviroNET via the dip switches on the PC board (except for the 2156 and 2157 models). The following CopperLink models are available with the EnviroNET Ethernet Extender series:

- “EnviroNET Model 2172” on page 23
- “EnviroNET Model 2168” on page 27
- “Other Models” on page 30

EnviroNET Model 2172

The EnviroNET Model 2172 has eight DIP switches for configuring the EnviroNET for a wide variety of applications. This section describes switch locations and explains the different configurations.

Figure 9 shows the orientation of the DIP switches in the On and Off positions.

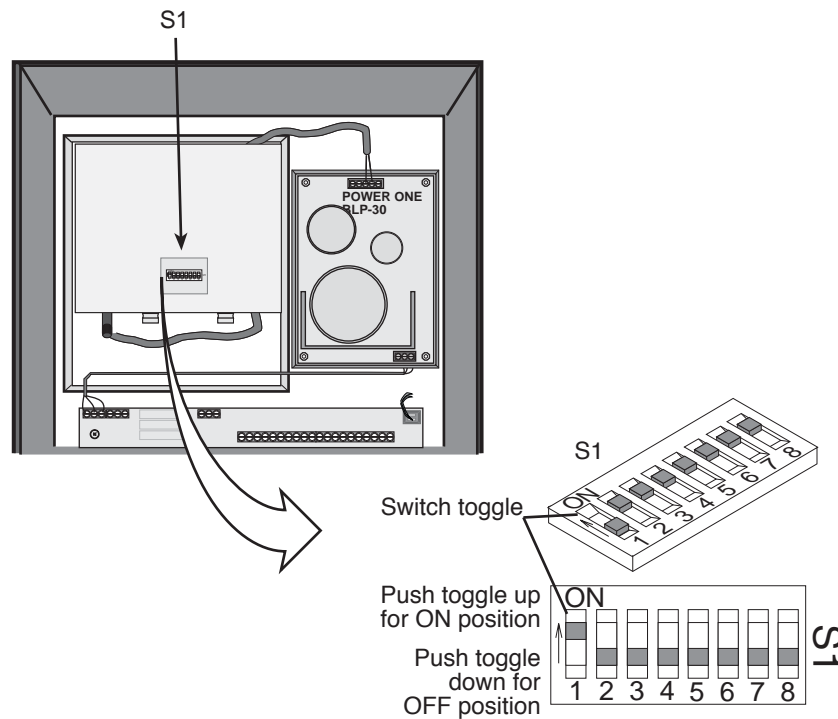

Figure 9. DIP switch orientation

Configuring DIP Switch S2

DIP switch S2 is where you configure the line rate, symmetric or asymmetric, Ethernet, and Ethernet Shutdown. Table 3 summarizes the default positions of DIP switches S2-1 through S2-8. Detailed descriptions of each switch follow the table.

Table 3. S2 Summary

Position	Description
S2-1	Symmetric/Asymmetric
S2-2	Line Rate
S2-3	Line Rate
S2-4	Ethernet configuration
S2-5	Ethernet configuration
S2-6	Ethernet configuration
S2-7	Ethernet Shutdown Enable
S2-8	Remote Configuration

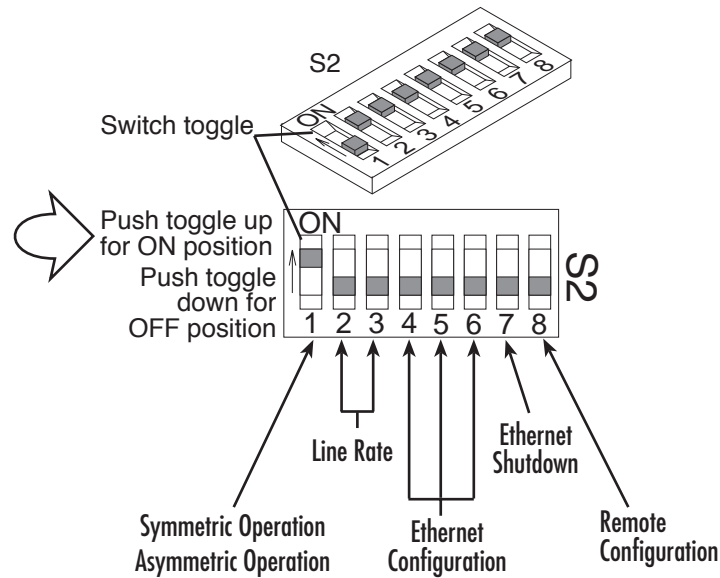

Figure 10. EnviroNET 2172 Dip Switch Settings

Switch 1: Symmetric/Asymmetric Operation

To configure the unit for symmetric or asymmetric operation, push the first toggle switch up or down. Refer to [table 4](#) for settings.

Table 4. Symmetric/Asymmetric Operation

S2-1	Setting
ON	Symmetric Operation
OFF	Asymmetric Operation

Switches 2 and 3: Data Rate

Refer to [table 5](#) for the symmetric line rate settings. (Switch 1 must be in the “On” position). Refer to [table 6](#) for the asymmetric line rate settings. (Switch 1 must be in the “Off” position).

Table 5. Symmetric CopperLink Line Rates Selection Chart

S2-2	S2-3	Symmetric Line Rate
OFF	ON	50 Mbps
ON	OFF	25 Mbps
OFF	OFF	10 Mbps

Table 6. Asymmetric CopperLink Line Rates Selection Chart

S2-2	S2-3	Asymmetric Line Rates DS/US
ON	ON	50 Mbps/2 Mbps
ON	OFF	16 Mbps/2 Mbps
OFF	OFF	4 Mbps/1 Mbps

Switches 4, 5 and 6: Ethernet Configuration

Refer to [table 7](#) to configure Ethernet settings with switches 4, 5, and 6.

Table 7. Ethernet configurations

S2-4	S2-5	S2-6	Ethernet Configurations
ON	ON	ON	Auto-Negotiate
ON	ON	OFF	100Mb Full Duplex
ON	OFF	ON	100Mb Half Duplex
ON	OFF	OFF	10Mb Full Duplex
OFF	ON	ON	10Mb Half Duplex

Switch 7: Ethernet Shutdown

To enable or disable Ethernet Shutdown, push toggle switch seven (7) up or down. Refer to [table 8](#) for settings.

Table 8. Ethernet Shutdown

S2-7	Description
ON	Ethernet Shutdown Enabled
OFF	Ethernet Shutdown Disabled

Switch 8: Remote Configuration

To enable or disable Remote Configuration, push toggle switch eight (8) up or down. Refer to [table 9](#) for settings.

Table 9. Remote Configuration

S2-8	Description
ON	Remote Configuration Enabled
OFF	Remote Configuration Disabled

Note The S2-8 switch applies to the remote unit only. If enabled, the remote unit will follow the dip switch configuration of the local unit. If disabled, the remote unit will use its own dip switch setting to determine its Ethernet operating mode and Ethernet Shutdown mode configuration. The S2-8 switch does not affect the data rate. The data rate will always follow the local configuration.

EnviroNET Model 2168

The EnviroNET Model 2168 has eight DIP switches for configuring the EnviroNET for a wide variety of applications. This section describes switch locations and explains the different configurations.

Figure 11 shows the orientation of the DIP switches in the On and Off positions.

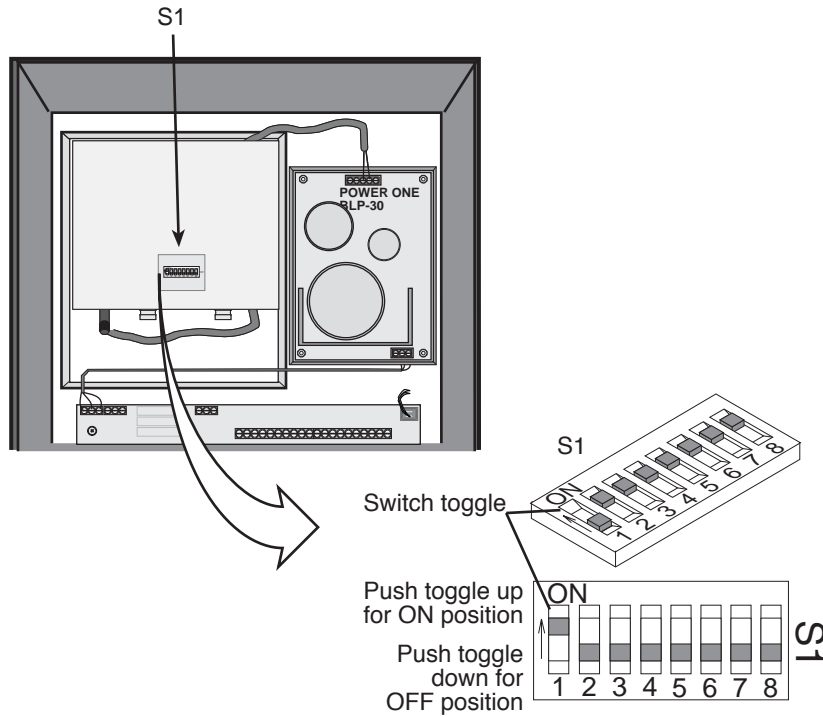

Figure 11. DIP switch orientation

Configuring DIP Switch S1

DIP switch S1 is where you configure the CopperLink line rate, symmetric or asymmetric, Ethernet full auto negotiation capability (100Base-T full or half duplex, 10Base-T full or half duplex) or limited auto sense (only 100Base-T half duplex, 10Base-T full or half duplex).

Table 10. S1 Summary

Position	Description
S1-1	Ethernet Auto Sense
S1-2	Line Rate
S1-3	Line Rate
S1-4	Line Rate
S1-5	Reserved
S1-6	Reserved
S1-7	Reserved
S1-8	Reserved

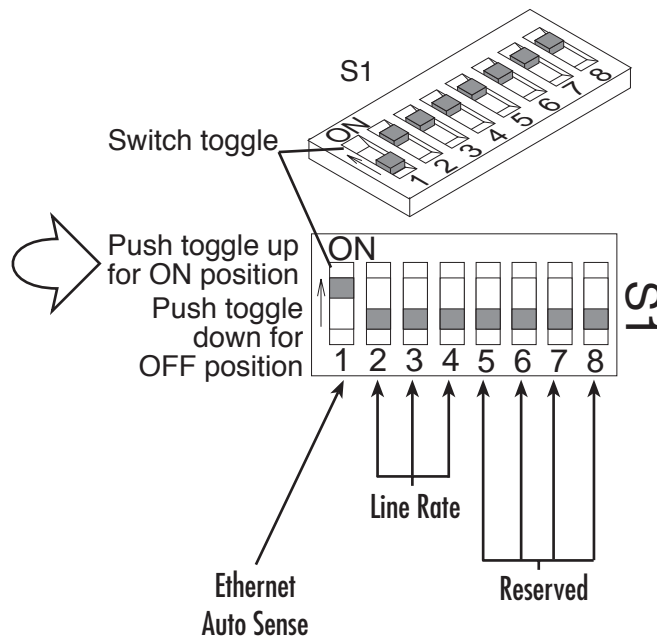

Figure 12. EnviroNET 2168 Dip Switch Settings

Switch 1: Ethernet Auto Sense

To configure the unit for full auto sense capability or limited auto sense capability, push the first toggle switch up or down. Full Auto sense capability consists of standard Ethernet Auto sensing (100BaseT full duplex, 100BaseT half duplex, 10BaseT full duplex, and 10BaseT half duplex). Limited Auto sensing capability consists on only auto sensing for 100BaseT half duplex, 10BaseT full duplex, and 10BaseT half duplex. The limited auto negotiation feature is used when an Ethernet device does not comply with IEEE 802.3x (back pressure flow control) at 100M full duplex.

Refer to [table 11](#) for settings.

Table 11. Ethernet Auto Sense Selection Chart

S1-1	Setting
OFF	Full Auto Negotiation (Factory Default) (100 Mbps, Full or Half Duplex) (10 Mbps, Full or Half Duplex)
ON	Limited Auto Negotiation (100 Mbps Half Duplex) 10 Mbps Full or Half Duplex)

Switches 2, 3, and 4: Data Rate

Refer to [table 12](#) for the symmetric line rate settings. (Switch 1 must be in the “On” position).

Refer to [table 13](#) for the asymmetric line rate settings.(Switch 1 must be in the “Off” position).

Table 12. Symmetric CopperLink Line Rates Selection Chart

S1-2	S1-3	S1-4	Symmetric Line Rate
ON	ON	ON	6.25 Mbps
ON	ON	OFF	9.38 Mbps
ON	OFF	OFF	12.5 Mbps (Factory Default)
ON	OFF	ON	16.67 Mbps

Table 13. Asymmetric CopperLink Line Rates Selection Chart

S1-2	S1-3	S1-4	Asymmetric Line Rates DS/US
OFF	OFF	ON	4.17 Mbps/1.56 Mbps (Mode 0)
OFF	ON	ON	9.38 Mbps/1.56 Mbps
OFF	ON	OFF	16.67 Mbps/2.34 Mbps

Switches 5, 6, 7, and 8: Reserved

Switches 5, 6, 7, and 8 are reserved and should be in the 'Off' position.

Table 14. Reserved for future use

S1-5	S1-6	S1-7	S1-8	Reserved
OFF	OFF	OFF	OFF	Reserved (Factory Default)

Other Models

No user configuration is necessary for the following models:

- EnviroNET 2157 Models (ET/EH/EC)
- EnviroNET 2156 Models (ET/EH/EC)

Chapter 4 **Operating the EnviroNET**

Chapter contents

Powering up the EnviroNET	32
LEDs (ET and EC models only).....	32
ET models	32
EC models	32
About Thermal Operation (ET Models only)	33
Operating the EnviroNET.....	33

Powering up the EnviroNET

The EnviroNET is designed to be powered on automatically. There is no power switch. The green power LED will light when the power is on (ET and EC models only).

To power the EnviroNET:

1. You need to wire the power cable. If you haven't done this already, go to the section, "Wiring the power" on page 17 in Chapter 2, "Installing the EnviroNET" .
2. After all of the cables are properly wired, close and lock the case. Plug the power cable into an electrical outlet.

Note Once in operation, the EnviroNET will run over all temperatures without user intervention.

LEDs (ET and EC models only)

The EnviroNET has two LEDs, **Power** and **Temperature Control Indicator**.

ET models

- **Power:** The Power light will be on when the EnviroNET is operating normally.
- **Temperature Control:** The Temperature Control Indicator light will be on when the heater is on. The heater will automatically come on at temperatures under -40°C (-40°F). When the Temperature Control Indicator light is on, the EnviroNET will not be powered on to operate and the Power light will be off.

EC models

- **Power:** The Power light will be on when the EnviroNET is operating normally.
- **Temperature Control:** The Temperature Control Indicator light will be on for temperature control conditions, such as when the fan is operating.

Note EH models do not have a fan or heater, therefore they do not have LEDs.

About Thermal Operation (ET Models only)

The ET model is the only EnviroNET model that includes a heater. The ET unit will not turn on at -40°C (-40°F). The heater controller monitors the temperature until it is warm enough to turn on the device. The device inside cannot be turned on below 0°C (32°F).

The heater controller will automatically start warming the inside of the unit until the internal temperature is above 0°C (32°F). During that warm-up period, the Temperature Control Indicator LED will light. The unit will take 20-30 minutes to power on from a cold start at -40°C (-40°F). Of course, warmer ambient temperatures will shorten this warm-up time.

Once the unit powers on, the unit will stay powered on when ambient temperatures drop below 0°C (32°F). At those times, the heater will turn on to maintain the proper internal temperature. The Temperature Control Indicator LED will light when the heater is on.

The fan will speed up cooling and heating times.

Operating the EnviroNET

If the EnviroNET has been configured correctly, it should operate normally without user intervention.

Because the EnviroNET Ethernet Extenders are configured using dip switches on the PC board, it is best to power down the unit before changing the configuration of the dip switches.

Chapter 5 **Contacting Patton for assistance**

Chapter contents

- Introduction35
- Contact information35
 - Patton support headquarters in the USA35
 - Alternate Patton support for Europe, Middle East, and Africa (EMEA)35
- Warranty Service and Returned Merchandise Authorizations (RMAs)35
 - Warranty coverage35
 - Out-of-warranty service36
 - Returns for credit36
 - Return for credit policy36
 - RMA numbers36
 - Shipping instructions36

Introduction

This chapter contains the following information:

- “Contact information”—describes how to contact Patton technical support for assistance.
- “Warranty Service and Returned Merchandise Authorizations (RMAs)”—contains information about the warranty and obtaining a return merchandise authorization (RMA).

Contact information

Patton Electronics offers a wide array of free technical services. If you have questions about any of our other products we recommend you begin your search for answers by using our technical knowledge base. Here, we have gathered together many of the more commonly asked questions and compiled them into a searchable database to help you quickly solve your problems.

Patton support headquarters in the USA

- Online support: available at www.patton.com
- E-mail support: e-mail sent to support@patton.com will be answered within 1 business day
- Telephone support: standard telephone support is available five days a week—from 8:00 am to 5:00 pm EST (1300 to 2200 UTC/GMT)—by calling +1 (301) 975-1007
- Fax: +1 (253) 663-5693

Alternate Patton support for Europe, Middle East, and Africa (EMEA)

- Online support: available at www.patton-inalp.com
- E-mail support: e-mail sent to support@patton-inalp.com will be answered within 1 business day
- Telephone support: standard telephone support is available five days a week—from 8:00 am to 5:00 pm CET (0900 to 1800 UTC/GMT)—by calling +41 (0)31 985 25 55
- Fax: +41 (0)31 985 25 26

Warranty Service and Returned Merchandise Authorizations (RMAs)

Patton Electronics is an ISO-9001 certified manufacturer and our products are carefully tested before shipment. All of our products are backed by a comprehensive warranty program.

Note If you purchased your equipment from a Patton Electronics reseller, ask your reseller how you should proceed with warranty service. It is often more convenient for you to work with your local reseller to obtain a replacement. Patton services our products no matter how you acquired them.

Warranty coverage

Our products are under warranty to be free from defects, and we will, at our option, repair or replace the product should it fail within one year from the first date of shipment. Our warranty is limited to defects in workmanship or materials, and does not cover customer damage, lightning or power surge damage, abuse, or unauthorized modification.

Out-of-warranty service

Patton services what we sell, no matter how you acquired it, including malfunctioning products that are no longer under warranty. Our products have a flat fee for repairs. Units damaged by lightning or other catastrophes may require replacement.

Returns for credit

Customer satisfaction is important to us, therefore any product may be returned with authorization within 30 days from the shipment date for a full credit of the purchase price. If you have ordered the wrong equipment or you are dissatisfied in any way, please contact us to request an RMA number to accept your return. Patton is not responsible for equipment returned without a Return Authorization.

Return for credit policy

- Less than 30 days: No Charge. Your credit will be issued upon receipt and inspection of the equipment.
- 30 to 60 days: We will add a 20% restocking charge (crediting your account with 80% of the purchase price).
- Over 60 days: Products will be accepted for repairs only.

RMA numbers

RMA numbers are required for all product returns. You can obtain an RMA by doing one of the following:

- Completing a request on the RMA Request page in the *Support* section at **www.patton.com**
- By calling **+1 (301) 975-1007** and speaking to a Technical Support Engineer
- By sending an e-mail to **returns@patton.com**

All returned units must have the RMA number clearly visible on the outside of the shipping container. Please use the original packing material that the device came in or pack the unit securely to avoid damage during shipping.

Shipping instructions

The RMA number should be clearly visible on the address label. Our shipping address is as follows:

Patton Electronics Company

RMA#: xxxx

7622 Rickenbacker Dr.

Gaithersburg, MD 20879-4773 USA

Patton will ship the equipment back to you in the same manner you ship it to us. Patton will pay the return shipping costs.

Appendix A **Compliance**

Chapter contents

Compliance	38
EMC Compliance:	38
Safety Compliance:	38
PSTN Regulatory Compliance:	38
Radio and TV Interference (FCC Part 15)	38
CE Declaration of Conformity	38
Authorized European Representative	39

Compliance

EMC Compliance:

- FCC Part 15, Class A
- EN55022, Class A
- EN61000-6-2

Safety Compliance:

- UL60950-1/CSA C22.2 No. 60950-1
- IEC/EN 60950-1
- AS/NZS 60950-1

PSTN Regulatory Compliance:

Note This device is NOT intended nor approved for connection to the PSTN. It is intended only for direct connection to customer premise equipment.

Radio and TV Interference (FCC Part 15)

This equipment generates and uses radio frequency energy, and if not installed and used properly—that is, in strict accordance with the manufacturer's instructions—may cause interference to radio and television reception. This equipment has been tested and found to comply with the limits for a Class A computing device in accordance with the specifications in Subpart B of Part 15 of FCC rules, which are designed to provide reasonable protection from such interference in a commercial installation. However, there is no guarantee that interference will not occur in a particular installation. If the equipment causes interference to radio or television reception, which can be determined by disconnecting the cables, try to correct the interference by one or more of the following measures: moving the computing equipment away from the receiver, re-orienting the receiving antenna, and/or plugging the receiving equipment into a different AC outlet (such that the computing equipment and receiver are on different branches).

CE Declaration of Conformity

We certify that the apparatus identified in this document conforms to the requirements of Council Directive 89/336/EEC, as amended by Directives 92/31/EEC and 93/68/EEC on the approximation of the laws of the member states relating to electromagnetic compatibility; and Council Directive 73/23/EEC, as amended by Directive 93/68/EEC, on the approximation of the laws of the member states relating to electrical equipment designed for use within certain voltage limits.

The safety advice in the documentation accompanying this product shall be obeyed. The conformity to the above directive is indicated by the CE sign on the device

Authorized European Representative

D R M Green

European Compliance Services Limited.

Oakdene House, Oak Road

Watchfield,

Swindon, Wilts SN6 8TD, UK

Appendix B **Specifications**

Chapter contents

EnviroNET Model 2156	41
EnviroNET Model 2157	42
EnviroNET Model 2168	42
EnviroNET Model 2172	43

EnviroNET Model 2156

Table 15. EnviroNET™ Ethernet Extender Model 2156 - Specific Specifications

CopperLINK Ethernet Extender - Model 2156	
Description	2.3 Mbps Ethernet Extender
Data Rate	2304 kbps
Diagnostics	V52 compliant (511/511E) pattern generator and detector with error injection mode and Remote Loopback control by a single front panel switch
Transmission Line	Single Twisted Pair of Copper
Line Coding	CAP (Carrierless Amplitude and Phase Modulation)
Line Interface	Transformer coupled, 1500 VAC isolation
Physical Connection	RJ-45, 2-wire, polarity insensitive pins 4 and 5
LAN Connection	RJ-45, 10Base-T 802.3 Ethernet
Protocol	Transparent to higher layer protocols. Supports 802.1 Q VLAN tagged packet transmission
LAN Address Table	4096 MAC Addresses
Frame Latency/ Buffer	1 Frame 512 Frames
Pins (RJ-45)	Pin 1 = Tx Data + Pin 2 = Tx Data - Pin 3 = Rx Data + Pin 6 = Rx Data + Pins 4,5,7,8 = no connection

EnviroNET Model 2157

Table 16. EnviroNET™ Ethernet Extender Model 2157 - Specific Specifications

CopperLINK Ethernet Extender - Model 2157	
Description	4.6 Mbps Ethernet Extender with Auto-Rate Adaptation
Line Rate	Auto-Rate adaptive from 192 kbps to 4.6 Mbps
DTE Rate	All 64k steps from 192 to 4608 kbps
Transmission Line	Single Twisted Pair of Copper
Line Coding	TC-PAM
Line Interface	Transformer coupled, 1500 VAC isolation
Connectors	RJ-11 on copper line side, RJ-45 for Ethernet connection, shrouded male IEC320 power connector
Protocol	Transparent to higher layer protocols. Supports 802.1 Q VLAN tagged packet transmission

EnviroNET Model 2168

Table 17. EnviroNET™ Ethernet Extender Model 2168 - Specific Specifications

CopperLINK Ethernet Extender - Model 2168	
Description	16.67 Mbps Multi-Rate Ethernet Extender
Line Interface	RJ-45 or terminal block
Ethernet Interface	Shielded RJ-45
Transmission	Switch selectable asynchronous and synchronous line rates up to 16.67 Mbps
Surge suppression	CopperLink 20kA (8/20ms) gas tube

EnviroNET Model 2172

Table 18. EnviroNET™ Ethernet Extender Model 2172 - -Specific Specifications

CopperLINK Ethernet Extender - Model 2172	
Description	50 Mbps Ethernet Extender
Line Interface	RJ-45 (pin 4 = ring; pin 5 = tip)
Ethernet Interface	8-position shielded RJ-45. Auto-sensing 10/100Base-T with half or full-duplex operation. DIP switch capable of disabling 100-Mbps full-duplex for equipment that does not support 802.3X (Pause Packets)
Protocol	Transparent to high layer protocol. Supports 802.1Q VLAN tagging
Modulation	Quadrature Amplitude Modulation (QAM) 4-band
Duplexing Method	Frequency Division Duplexing (FDD)
Frequency Range	CopperLink: 0–12 MHz
Transmission	CopperLink line rate: Up to 50 Mbps
Surge suppression	CopperLink line maximum current surge: 20kA (8/20 μ s) gas tube