

SmartNode 1000 and 2000 Series **VoIP Media Gateways**

Getting Started Guide



Sales Office: +1 (301) 975-1000
Technical Support: +1 (301) 975-1007
E-mail: support@patton.com
WWW: www.patton.com

Document Number: 132061U Rev. B
Part Number: 07MDSN2000-G5
Revised: November 10, 2003

Patton Electronics Company, Inc.

7622 Rickenbacker Drive
Gaithersburg, MD 20879 USA
tel: +1 (301) 975-1000
fax: +1 (301) 869-9293
support: +1 (301) 975-1007
url: www.patton.com
e-mail: support@patton.com

Copyright Statement

Copyright © 2003, Patton Electronics Company. All rights reserved.

Trademark Statement

The terms *SmartWare*, *SmartView*, and *SmartNode* are trademarks of Patton Electronics Company. All other trademarks presented in this document are the property of their respective owners.

Notices

The information contained in this document is not designed or intended for use as critical components in human life-support systems, equipment used in hazardous environments, or nuclear control systems. Patton Electronics Company disclaims any express or implied warranty of fitness for such uses.

The information in this document is subject to change without notice. **Patton Electronics** assumes no liability for errors that may appear in this document.

Any software described in this document is furnished under license and may be used or copied only in accordance with the terms of such license.

Contents

Contents	3
Compliance Information	9
Radio and TV Interference	9
CE Notice	9
EU Declaration of Conformity	9
The basis on which conformity is being declared	9
Service	10
About this guide	11
Audience.....	11
How to read this guide	11
Structure.....	12
Precautions	12
Safety when working with electricity	13
Preventing Electrostatic Discharge Damage	14
General Observations	14
Typographical conventions used in this document.....	14
General conventions	14
Mouse conventions	15
1 General Information	17
Introduction	19
SmartNode 1200 description.....	20
Front panel	20
Rear panel	21
SmartNode 1400 description.....	23
Front panel	23
Rear panel	24
SmartNode 2300 description.....	26
Front panel	26
Rear panel	27
Expansion slots	27
On-board ports	27
SmartNode 2400 description.....	29
Front panel	29
Rear panel	30
Expansion slots	30
On-board ports	30
Interface cards descriptions	32
IC-4FXS Gateway interface card for 4 analog FXS ports	32
Front panel	32
Ports	33

Description	33
IC-4BRV 8-channel gateway interface card for ISDN BRI	33
Front panel	34
Ports	34
Description	34
Operating modes	35
Hardware bypass	35
Network integration	36
S-Bus line power	38
Line power jumper settings	38
Jumper settings for IC-4BRV and PM-48V-INT (or PM-40V-INT)	39
IC-E1V 30-channel E1 gateway interface card for ISDN PRI	40
Front panel	41
Interface	41
Description	41
Interface modes	42
IC-T1V 23-channel T1 gateway interface card for ISDN PRI	42
Front panel	43
Interface	43
Description	43
Interface modes	44
2 Product Overview.....	45
Introduction	47
System model of the SmartNode 1000 and 2000 Series.....	48
Voice routing.....	48
SmartNode deployment.....	49
Customer premises gateway; multi-service providers	49
Small office or home office (SOHO)	49
Small and medium enterprise (SME)	50
Multi-service gateway/router for private enterprise networks	52
Company branch office	52
Company headquarters	53
IP access to the WAN	53
ISDN Gateway; LAN-based PBX or call center applications	54
LAN-based telephony gateways (GW)	54
3 Planning the installation	55
Introduction.....	57
Installation checklist	58
Site Log	58
Network information	59
Network diagram	59
IP related information	59
ISDN related information	59

S-Bus installation	59
SmartNode BRI port configured in USR mode and connected to an S-Bus	60
SmartNode BRI port configured in NET mode	60
Installing an S-Bus power supply	60
Synchronous serial interface	60
Software tools	61
Power source	61
Where to go next	61
4 SmartNode 1200 installation.....	63
Hardware installation	65
Mounting the SmartNode 1200	65
Desktop installation	65
Wall-mounted installation	66
Connecting cables.....	67
Installing the Ethernet cables	67
Installing the BRI cables	68
External S-Bus power supply	70
Installing the power cord	73
5 SmartNode 1400 installation.....	75
Hardware installation	77
Mounting the SmartNode 1400	77
Desktop installation	77
Wall-mounted installation	78
Connecting cables.....	79
Installing the Ethernet cables	79
Installing the BRI cables	80
External S-Bus power supply	82
Installing the power cord	84
6 SmartNode 2300 installation.....	85
Hardware installation	87
Mounting the SmartNode 2300	87
Desktop installation	88
Rack-mounted installation	88
Connecting cables.....	90
Installing the Ethernet cables	91
Installing the serial interface cable	92
Installing the interface card cables	94
Installing the IC-4FXS interface card cables	94
Installing the IC-4BRV interface card cables	95
Installing the IC-E1V interface card cables	97
Installing the IC-T1V interface card cables	98
Installing the power cord	99

7	SmartNode 2400 installation	101
	Hardware installation	103
	Mounting the SmartNode 2400	103
	Desktop installation	104
	Rack-mounted installation	104
	Connecting cables.....	106
	Installing the Ethernet cables	107
	Installing the interface card cables	108
	Installing the IC-4FXS interface card cables	109
	Installing the IC-4BRV interface card cables	110
	Installing the IC-E1V interface card cables	111
	Installing the IC-T1V interface card cables	113
	Installing the power cord	114
8	Line power module installation	115
	Introduction	117
	Safety Recommendation	117
	Internal PM-48V-INT or PM-40V-INT line power module installation.....	117
	SmartNode 2300 line power module installation	118
	SmartNode 2400 line power module installation	120
	Completing the installation	121
	External S-Bus power supply	122
9	Interface card installation	123
	Introduction	125
	Safety Recommendation	125
	Installing interface cards	126
	Card locating screws	127
10	Getting Started with the SmartNode Device	129
	Introduction	131
	1. Configure IP address	132
	Power connection and default configuration	132
	Connect with the serial interface	132
	Login	133
	Changing the IP address	133
	2. Connect the SmartNode to the network.....	134
	3. Load configuration	134
	Additional information.....	135
11	Monitoring Status	137
	Status LEDs.....	139
12	Contacting Patton for assistance	141
	Introduction.....	143
	Contact information.....	143
	Warranty Service and Returned Merchandise Authorizations (RMAs).....	143

Warranty coverage	143
Out-of-warranty service	143
Returns for credit	143
Return for credit policy	144
RMA numbers	144
Shipping instructions	144
A Specifications	145
Physical description	147
SN1200	147
SN1400	147
SN2300	147
SN2400	147
IC-4BRV	148
IC-E1V	148
IC-4FXS	148
Line power module	148
B Cabling	149
Introduction	151
Serial console	151
Ethernet 10Base-T and 100Base-T	152
V.35 and X.21	152
BRI	154
E1 PRI	156
T1 PRI	157
C Port pin-outs	159
Introduction	161
Console port	161
Ethernet 10Base-T and 100Base-T port	161
BRI port	161
FXS port	162
PRI port	162
Serial port	163

Compliance Information

Radio and TV Interference

The SmartNode series of products generate and use radio frequency energy, and if not installed and used properly—that is, in strict accordance with the manufacturer’s instructions—may cause interference to radio and television reception. The SmartNode devices have been tested and found to comply with the limits for a Class A computing device in accordance with specifications in Subpart B of Part 15 of FCC rules, which are designed to provide reasonable protection from such interference in a commercial installation. However, there is no guarantee that interference will not occur in a particular installation. If a SmartNode series device does cause interference to radio or television reception, which can be determined by disconnecting the unit, the user is encouraged to try to correct the interference by one or more of the following measures: moving the computing equipment away from the receiver, re-orienting the receiving antenna and/or plugging the receiving equipment into a different AC outlet (such that the computing equipment and receiver are on different branches).

CE Notice

The CE symbol on your Patton Electronics equipment indicates that it is in compliance with the Electromagnetic Compatibility (EMC) directive and the Low Voltage Directive (LVD) of the European Union (EU). A Certificate of Compliance is available by contacting Technical Support.

EU Declaration of Conformity

The following statements apply to the SmartNode 1200, 1400, and 2300 Series.

EU Directives covered by this declaration

89/336/EEC	Electromagnetic Compatibility Directive amended by 92/31/EEC & 93/68/EEC
72/23/EEC	Low Voltage Equipment Directive amended by 93/68/EEC

Note During the transition period, products may not comply with the Low Voltage Directive.

The basis on which conformity is being declared

The products identified above comply with the requirements of the above EU directives by meeting the following standards:

- Safety compliance: EN 60950
- EMC compliance: EN 55022, EN 55024
- ETSI TBR3 (BRI)
- TBR4 (PRI)

The CE mark was first applied in 2000.

Service

All warranty and non-warranty repairs must be returned freight prepaid and insured to Patton Electronics. All returns must have a Return Materials Authorization number on the outside of the shipping container. This number may be obtained from Patton Electronics Technical Services at:

- Tel: **+1 (301) 975-1007**
- Email: **support@patton.com**
- URL: **http://www.patton.com**

Note Packages received without an RMA number will not be accepted.

About this guide

This guide provides hardware information concerning SmartNode devices and their interface cards. The installation of the cards and the cabling of the devices are also described. The goal is to enable you to install such devices, alone or under supervision.

The information included in this guide consists of:

- Hardware descriptions of the SmartNodes
- Hardware descriptions of the extension interface cards
- Hardware installation instructions
- LED indications
- Cabling and pin-out data

Note The guide describes three SmartNode models that are similar in functionality, but differ in the number and type of interfaces that they support. Because of this some of the information provided may not apply to your particular SmartNode model.

For software configuration information and initial SmartNode installation refer to the *Software Configuration Guide*.

Audience

The guide is intended for the following audiences:

- Technical staff who are familiar with electronic circuitry, networking theory and have experience as an electronic or electromechanical technician.
- System administrators with a basic networking background and experience, but who might not be familiar with the SmartNode.
- System administrators who are responsible for installing and configuring networking equipment and who are familiar with the SmartNode.

How to read this guide

SmartWare is a complex and multifaceted operating system running on your SmartNode device. Without the necessary theoretical background you will not be able to understand and consequently use all the features available. Therefore we recommend reading at least the chapters listed below to get a general idea about SmartWare and the philosophy of contexts used for IP and circuit switching related configuration.

- Chapter 1, "[General Information](#)" on page 17
- Chapter 4, "[SmartNode 1200 installation](#)" on page 63
- Chapter 5, "[SmartNode 1400 installation](#)" on page 75
- Chapter 6, "[SmartNode 2300 installation](#)" on page 85
- Chapter 7, "[SmartNode 2400 installation](#)" on page 101
- Chapter 8, "[Line power module installation](#)" on page 115
- Chapter 9, "[Interface card installation](#)" on page 123

Structure

This guide contains the following chapters and appendices:

- [Chapter 1](#) provides information about SmartNode features and capabilities
- [Chapter 2](#) contains an overview describing SmartNode operation
- [Chapter 3](#) lists items and information that should be at hand before you begin installing the SmartNode device
- [Chapter 4](#) describes installing the SmartNode 1200
- [Chapter 5](#) describes installing the SmartNode 1400
- [Chapter 6](#) describes installing the SmartNode 2300
- [Chapter 7](#) describes installing the SmartNode 2400
- [Chapter 8](#) describes installing the line power module
- [Chapter 9](#) describes installing interface cards
- [Chapter 10](#) describes how to configure the SmartNode for operation
- [Chapter 11](#) describes SmartNode status LEDs
- [Chapter 12](#) provides information for contacting Patton Electronics
- [Appendix A](#) contains specifications for the SmartNode devices
- [Appendix B](#) provides cable recommendations
- [Appendix C](#) describes the router's ports

For best results, read the contents of this guide *before* you install the router.

Precautions

This section lists safety warnings that you should be aware of before installing a SmartNode or an interface card in a SmartNode.

Notes and cautions, which have the following meanings, are used throughout this guide to help you become aware of potential problems. *Warnings* relate to personal injury issues, and *Cautions* refer to potential property damage.

Note Calls attention to important information.



The shock hazard symbol and WARNING heading indicate a potential electric shock hazard. Strictly follow the warning instructions to avoid injury caused by electric shock.



The alert symbol and WARNING heading indicate a potential safety hazard. Strictly follow the warning instructions to avoid personal injury.



CAUTION

The shock hazard symbol and CAUTION heading indicate a potential electric shock hazard. Strictly follow the instructions to avoid property damage caused by electric shock.



CAUTION

The alert symbol and CAUTION heading indicate a potential hazard. Strictly follow the instructions to avoid property damage.

Safety when working with electricity



WARNING

Mains Voltage: Do not open the case when the power cord is connected. For systems without a power switch, line voltages are present within the power supply when the power cord is connected.



WARNING

Hazardous network voltages are present in WAN ports regardless of whether power to the SmartNode is ON or OFF. To avoid electric shock, use caution when near WAN ports. When detaching cables, detach the end away from the SmartNode first.



WARNING

Do not work on the system or connect or disconnect cables during periods of lightning activity.



CAUTION

Before opening the chassis, disconnect the telephone network cables to avoid contact with telephone line voltages.



CAUTION

Ultimate disposal of this equipment must be handled according to all applicable national laws and regulations.

Preventing Electrostatic Discharge Damage

When starting to install interface cards place the interface card on its shielded plastic bag if you lay it on your bench.



CAUTION

Electrostatic Discharge (ESD) can damage equipment and impair electrical circuitry. It occurs when electronic printed circuit cards are improperly handled and can result in complete or intermittent failures. Do the following to prevent ESD:

- Always follow ESD prevention procedures when removing and replacing cards.
- Ensure that the SmartNode chassis is electrically connected to earth ground.
- Wear an ESD-preventive wrist strap, ensuring that it makes good skin contact. Connect the clip to an unpainted surface of the chassis frame to safely channel unwanted ESD voltages to ground.
- To properly guard against ESD damage and shocks, the wrist strap and cord must operate effectively. If no wrist strap is available, ground yourself by touching the metal part of the chassis.

General Observations

- Clean the case with a soft slightly moist anti-static cloth
- Place the unit on a flat surface (or optionally in a rack for the SmartNode 2000 Series) and ensure free air circulation
- Avoid exposing the unit to direct sunlight and other heat sources
- Protect the unit from moisture, vapors, and aggressive liquids

Typographical conventions used in this document

This section describes the typographical conventions and terms used in this guide.

General conventions

The procedures described in this manual use the following text conventions:

Table 1. General conventions

Convention	Meaning
Garamond blue type	Indicates a cross-reference hyperlink that points to a figure, graphic, table, or section heading. Clicking on the hyperlink jumps you to the reference. When you have finished reviewing the reference, click on the Go to Previous View button  in the Adobe® Acrobat® Reader toolbar to return to your starting point.
Futura bold type	Commands and keywords are in boldface font.
<i>Futura bold-italic type</i>	Parts of commands, which are related to elements already named by the user, are in boldface italic font.
<i>Italicized Futura type</i>	Variables for which you supply values are in <i>italic</i> font

Table 1. General conventions (Continued)

Convention	Meaning
Futura type	Indicates the names of fields or windows.
Garamond bold type	Indicates the names of command buttons that execute an action.
< >	Angle brackets indicate function and keyboard keys, such as <SHIFT>, <CTRL>, <C>, and so on.
[]	Elements in square brackets are optional.
{a b c}	Alternative but required keywords are grouped in braces ({ }) and are separated by vertical bars ()
blue screen	Information you enter is in blue screen font.
screen	Terminal sessions and information the system displays are in screen font.
node	The leading IP address or nodename of a SmartNode is substituted with node in boldface italic font.
SN	The leading SN on a command line represents the nodename of the SmartNode
#	An hash sign at the beginning of a line indicates a comment line.

Mouse conventions

The following conventions are used when describing mouse actions:

Table 2. Mouse conventions

Convention	Meaning
Left mouse button	This button refers to the primary or leftmost mouse button (unless you have changed the default configuration).
Right mouse button	This button refers the secondary or rightmost mouse button (unless you have changed the default configuration).
Point	This word means to move the mouse in such a way that the tip of the pointing arrow (referred to as the <i>cursor</i>) on the screen ends up resting at the desired location.
Click	Means to press and release the left or right mouse button one time quickly (as instructed in the procedure). Make sure you do not move the cursor while clicking a mouse button.
Double-click	Means to press and release the same mouse button two times quickly. Make sure you do not move the cursor while clicking a mouse button.
Drag	This word means to place the cursor and then hold down the left or right mouse button (as instructed in the procedure) as you move the mouse to a new location. When you have moved the cursor to the desired location, you can release the mouse button.

Chapter 1 **General Information**

Chapter contents

Introduction	19
SmartNode 1200 description	20
Front panel	20
Rear panel	21
SmartNode 1400 description	23
Front panel	23
Rear panel	24
SmartNode 2300 description	26
Front panel	26
Rear panel	27
Expansion slots	27
On-board ports	27
SmartNode 2400 description	29
Front panel	29
Rear panel	30
Expansion slots	30
On-board ports	30
Interface cards descriptions	32
IC-4FXS Gateway interface card for 4 analog FXS ports	32
Front panel	32
Ports	33
Description	33
IC-4BRV 8-channel gateway interface card for ISDN BRI	33
Front panel	34
Ports	34
Description	34
Operating modes	35
Hardware bypass	35
Network integration	36
S-Bus line power	38
Line power jumper settings	38
Jumper settings for IC-4BRV and PM-48V-INT (or PM-40V-INT)	39
IC-E1V 30-channel E1 gateway interface card for ISDN PRI	40
Front panel	41
Interface	41
Description	41
Interface modes	42
IC-T1V 23-channel T1 gateway interface card for ISDN PRI	42
Front panel	43

Interface43
Description43
Interface modes44

Introduction

This guide describes installing the SmartNode 1000 Series and 2000 Series devices.

The SmartNode 1000 series are compact IP access devices for applications in SOHO or branch office environments. Two models are currently available with 2 or 4 voice over IP channels (see [figure 1](#)):

- **SmartNode 1200**—Dual Ethernet router, 2-channel ISDN BRI gateway (see “[SmartNode 1200 description](#)” on page 20)
- **SmartNode 1400**—Dual Ethernet router, 4-channel ISDN BRI gateway (see “[SmartNode 1400 description](#)” on page 23)



Figure 1. SmartNode 1000 Series and 2000 Series VoIP media gateways, and interface cards

The SmartNode 2000 Series are modular IP network nodes designed for medium and large enterprise applications. The 2000 series features expansion slots for a range of interface cards. Currently available models are (see [figure 1](#)):

- **SmartNode 2300**—Serial/Ethernet router with three expansion slots for interface cards (see “[SmartNode 2300 description](#)” on page 26)
- **SmartNode 2400**—High performance router with four expansion slots for interface cards (see “[SmartNode 2400 description](#)” on page 29)

The following interface cards (see [figure 1](#)) are available for use with the SmartNode 2000 Series devices (see “[Interface cards descriptions](#)” on page 32):

- **IC-4FXS**—Gateway interface card for 4 analog FXS ports
- **IC-4BRV**—8-channel gateway interface card for ISDN BRI
- **IC-E1V**—30-channel E1 gateway interface card for ISDN PRI
- **IC-T1V**—23-channel T1 gateway interface card for ISDN PRI

SmartNode 1200 description

The SmartNode Model 1200 (see [figure 2](#)) is a compact voice/data access device that supports two voice channels. The user interfaces consist of one ISDN BRI port and one Ethernet 10Base-T port. Network access comprises one ISDN BRI port and one Ethernet 10Base-T port. It is suitable for home office or small office applications. The ventilated metal case can be placed on a desktop or be wall-mounted.



Figure 2. Model 1200 (front and rear views shown)

Front panel

The Model 1200 front panel (see [figure 3](#)) includes the following LEDs for at-a-glance status display:

- *POWER* and *RUN* LEDs that indicate the device status.
- *BRI0*, *BRI1*, *ETH0*, and *ETH1* LEDs that indicate the status of the interfaces.

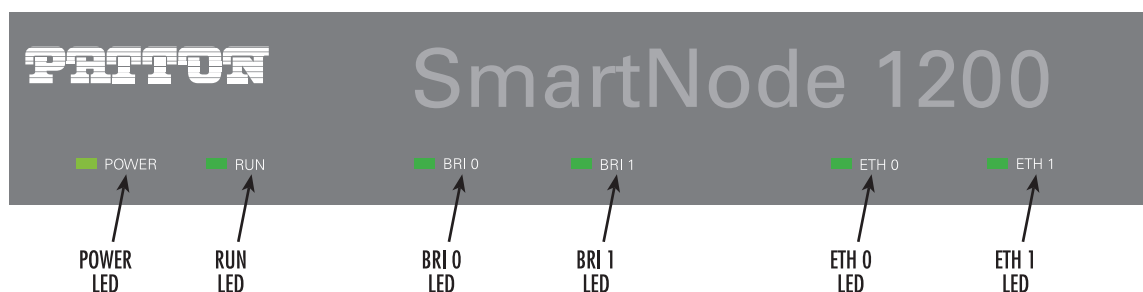

Figure 3. SmartNode 1200 front panel

See chapter 11, “[Monitoring Status](#)” on page 137, for more information on LED indications.

Rear panel

The SmartNode 1200 rear panel includes the following LEDs for at-a-glance status display (see [figure 4](#)):

- *LINK* LEDs that indicate the status of the Ethernet connections
- *L2* LEDs that show the status of the BRI interfaces

The ports are described in [table 3](#) (see appendix B, “Cabling” on page 149 for connection cable and appendix C, “Port pin-outs” on page 159 for pin-out data).

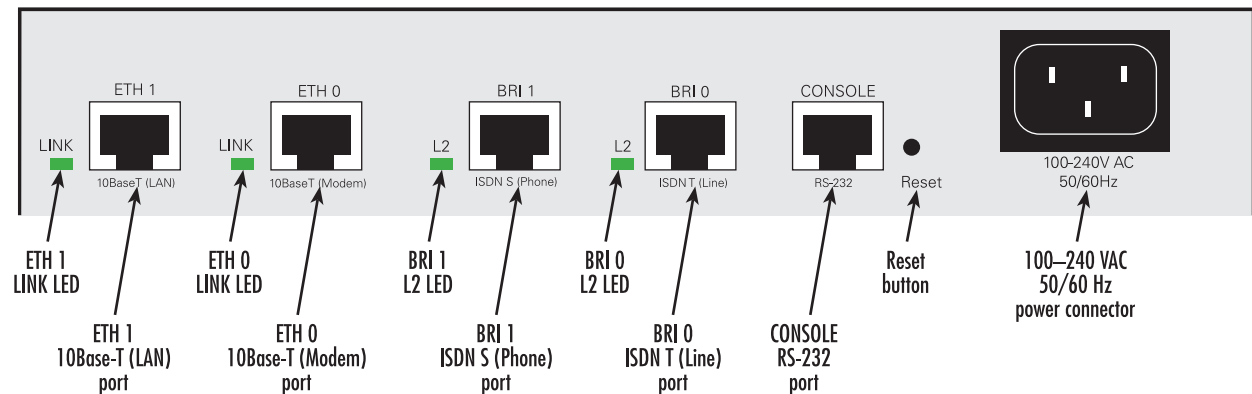

Figure 4. SmartNode 1200 rear panel

Table 3. SmartNode 1200 port description

Port	Description
ETH 0 10Base-T (Modem)	10Base-T Ethernet RJ-45 socket that connects the SmartNode with an Ethernet device (usually a transmission modem, i.e. cable or DSL modem). <i>ETH 0</i> is a host port; depending on the pin out of the modem, it can be connected with a straight-through wired cable or a cross-over cable. The <i>LINK</i> LED to the left of the connector is lit when the port is connected correctly to an active Ethernet device.
ETH 1 10Base-T (LAN)	10Base-T Ethernet RJ-45 socket that connects the SmartNode with an Ethernet device, usually a LAN hub or switch. <i>ETH 1</i> is a host port; it can be connected with a straight-through wired cable to a hub or a cross-over cable to a host (PC) port. The <i>LINK</i> LED to the left of the connector is lit when the port is connected correctly to an active Ethernet device.
BRI 0 ISDN T (Line)	ISDN BRI RJ-45 socket that connects the SmartNode with an ISDN network termination (NT). The interface may be used as a fallback port. The <i>L2</i> LED to the left of the connector is lit when the port is connected correctly to an active ISDN device (Layer 1 is up). The interface is internally terminated at 100 ohm. It may be powered by an external power supply to feed TEs connected to BRI 1. Refer to appendix B, “Cabling” on page 149 for connection details. Note External S-Bus power supplies must comply with the voltage and current limits set by ISDN standards, i.e. max. 40 VDC and 200 mA. Note The <i>L2</i> LED indication depends on the connected device.

Table 3. SmartNode 1200 port description (Continued)

Port	Description
BRI 1 ISDN S (Phone)	ISDN BRI RJ-45 socket that connects the SmartNode with an ISDN S-Bus, e.g. a PBX. The L2 LED to the left of the connector is lit when the port is connected correctly to an active ISDN device (Layer 1 is up). The interface is internally terminated at 100 ohm. Note The L2 LED indication depends on the connected device.
Console (RS-232)	RS-232 RJ-45 connector that connects the SmartNode with a serial terminal such as a PC or workstation with an RS-232 interface, with the following settings: <ul style="list-style-type: none"> • 9600 baud, no parity, 8 bit, 1 stop bit, 1 start bit • The console port is only used for service and maintenance



Do not plug in an ISDN connection. The voltage on the S-Bus may permanently damage the console interface.

In addition, two other elements—the *Reset* button and power input socket—are available on the rear panel of a SmartNode 1200 as described in [table 4](#).

Table 4. SmartNode 1200 Reset button and power line socket on rear panel

Element	Description
Reset button	The button has three different functions: <ul style="list-style-type: none"> • Manual Restart—During normal operation, pressing and releasing the reset button will cause a system reboot. The application will be restarted without any change to the existing SmartWare configuration. • Restoration—Pressing and holding the reset button for 5 seconds will restore the factory configuration and automatically reboot the system. <p>Note In this case the existing IP SmartWare configuration is lost.</p> <ul style="list-style-type: none"> • Boot loader—Powering the SmartNode while pressing the reset button for 5 seconds will cause the factory-fitted boot loader to start in place of the application. The boot loader uses a minimal set of parameters. In case the application does not start correctly, the boot loader can be used as a fallback to download a new software version.
100–240 VAC 50/60 Hz	Electricity supply socket for mains power cable.

SmartNode 1400 description

The SmartNode Model 1400 (see [figure 5](#)) is a compact voice/data access device that supports four voice channels. The interfaces consist of two ISDN BRI ports and two Ethernet 10Base-T ports. It is suitable for enterprise networking and small office environments. The ventilated metal case can be wall-mounted or placed on a desktop.



Figure 5. Model 1400 (front and rear views shown)

Front panel

The Model 1400 front panel (see [figure 7](#)) includes the following LEDs for at-a-glance status display:

- *POWER* and *RUN* LEDs that indicate the device status
- *BRI0*, *BRI1*, *ETH0*, and *ETH1* LEDs that indicate the status of the interfaces

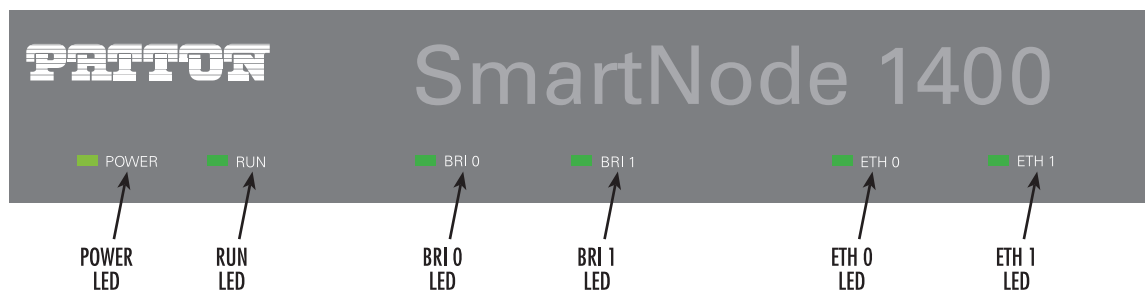

Figure 6. SmartNode 1400 front panel

See chapter 11, “[Monitoring Status](#)” on page 137 for more information on LED indications.

Rear panel

The SmartNode 1400 rear panel includes the following LEDs for at-a-glance status display (see [figure 4](#)):

- *LINK* LEDs that indicate the status of the Ethernet connections
- *L2* LEDs that show the status of the BRI interfaces

The ports are described in [table 5](#) (see appendix B, “Cabling” on page 149 for connection cable and appendix C, “Port pin-outs” on page 159 for pin-out data).

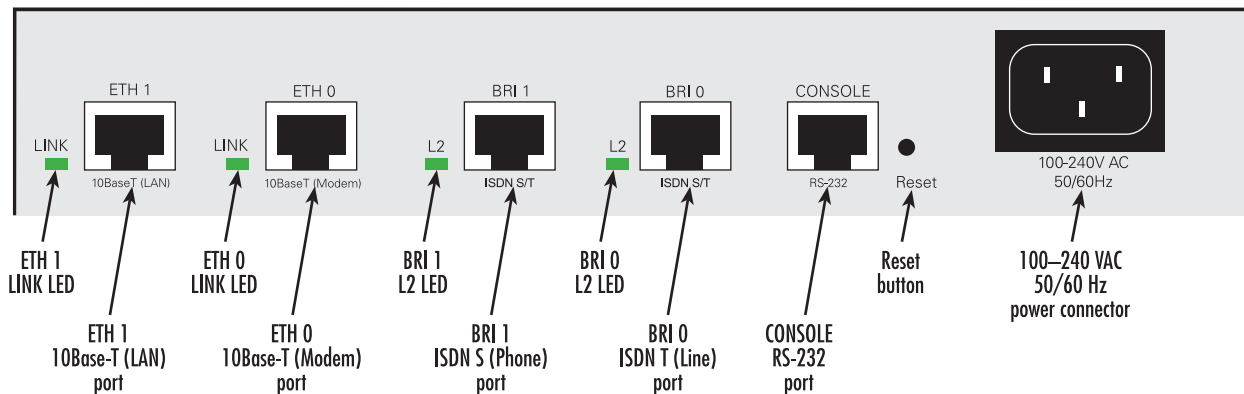

Figure 7. SmartNode 1400 rear panel

Table 5. SmartNode 1400 port description

Port	Description
ETH 0 10Base-T (Modem)	10Base-T Ethernet RJ-45 socket that connects the SmartNode with an Ethernet device (usually a transmission modem, i.e. cable or DSL modem). <i>ETH 0</i> is a host port; depending on the pin out of the modem, it can be connected with a straight-through wired cable or a cross-over cable. The <i>LINK</i> LED to the left of the connector is lit when the port is connected correctly to an active Ethernet device.
ETH 1 10Base-T (LAN)	10Base-T Ethernet RJ-45 socket that connects the SmartNode with an Ethernet device, usually a LAN hub or switch. <i>ETH 1</i> is a host port; it can be connected with a straight-through wired cable to a hub or a cross-over cable to a host (PC) port. The <i>LINK</i> LED to the left of the connector is lit when the port is connected correctly to an active Ethernet device.
BRI 0 ISDN S/T	ISDN BRI RJ-45 socket that connects the SmartNode with an ISDN device over an S/T bus, e.g. a PBX or an NT. The interface may be used as fallback if connected to an NT. The <i>L2</i> LED to the left of the connector is lit when the port is connected correctly to an active ISDN device (Layer 1 is up). The pin-out is configurable; see the document SmartWare Software Configuration Guide. The interface is internally terminated at 100 ohm. It may be powered by an external power supply to feed TEs connected to BRI 1. Refer to appendix B, “Cabling” on page 149 for connection details. Note External S-Bus power supplies must comply with the voltage and current limits set by ISDN standards, i.e. max. 40 VDC and 200 mA. Note The <i>L2</i> LED indication depends on the connected device.

Table 5. SmartNode 1400 port description (Continued)

Port	Description
BRI 1 ISDN S/T	ISDN BRI RJ-45 socket that connects the SmartNode with an ISDN device over an S/T bus, such as a PBX. The L2 LED to the left of the connector is lit when the port is connected correctly to an active ISDN device (Layer 1 is up). The pin out is configurable; see the document <i>SmartWare Software Configuration Guide</i> . The interface is internally terminated at 100 ohm. Note The L2 LED indication depends on the connected device.
Console (RS-232)	RS-232 RJ-45 connector that connects the SmartNode with a serial terminal such as a PC or workstation with a RS-232 interface, with the following settings: <ul style="list-style-type: none"> • 9600 baud, no parity, 8 bit, 1 stop bit, 1 start bit • The console port is only used for service and maintenance



Do not plug in an ISDN connection. The voltage on the S-Bus may permanently damage the console interface.

In addition, two other elements—the *Reset* button and power input socket—are available on the rear panel of a SmartNode 1200 as described in [table 6](#).

Table 6. SmartNode 1200 Reset button and power line socket on rear panel

Element	Description
Reset button	The button has three different functions: <ul style="list-style-type: none"> • Manual Restart—During normal operation pressing and releasing the reset button will cause a system reboot. The application will be restarted without any change to the existing SmartWare configuration. • Restoration—Pressing and holding the reset button for 5 seconds will restore the factory configuration and automatically reboot the system. <p>Note In this case the existing IP SmartWare configuration is lost.</p> <ul style="list-style-type: none"> • Boot loader—Powering the SmartNode while pressing the reset button for 5 seconds will cause the factory-fitted boot loader to start in place of the application. The boot loader uses a minimal set of parameters. In case the application does not start correctly, the boot loader can be used as a fallback to download a new software version.
100–240 VAC 50/60 Hz	Electricity supply socket for mains power cable.

SmartNode 2300 description

The SmartNode Model 2300 (see [figure 8](#)) is a powerful multi-service access device. The 19-in. aluminum chassis can be rack-mounted and it provides three expansion slots for interface cards.

Note If you will be mounting the SmartNode 2300 in a 19-in. rack, see section “[Mounting the SmartNode 2300](#)” on page 87 for details.



Figure 8. Model 2300 (front and rear views shown)

Front panel

The SmartNode 2300 rear panel includes the *PWR*, *RUN*, and *ACT* LEDs that indicate the status of the device (see [figure 9](#)). See chapter 11, “[Monitoring Status](#)” on page 137 for detailed information on the LED states.



Figure 9. SmartNode 2300 front panel

See chapter 11, “[Monitoring Status](#)” on page 137 for more information on LED indications.

Rear panel

The SmartNode 2300 rear panel is depicted in [figure 10](#). There are three expansion slots for optional interface cards, and four board-mounted sockets. The *Status*, *LINK*, and *100Mb/s* LEDs indicate the status of the on-board interfaces (see appendix B, “Cabling” on page 149 for connection cable and appendix C, “Port pin-outs” on page 159 for pin-out data).

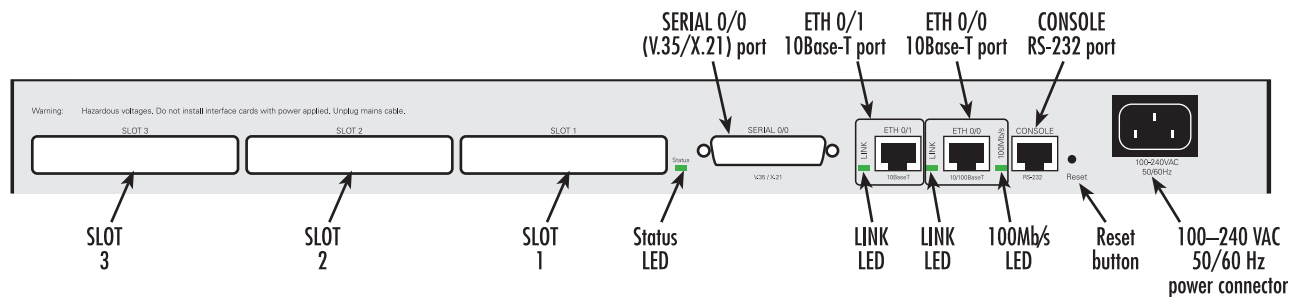

Figure 10. SmartNode 2300 rear panel

Expansion slots

The slots labeled *SLOTT 1*, *SLOTT 2*, and *SLOTT 3* (see [figure 10](#)) accept different PMC interface cards to integrate voice and data over IP networks (see “Interface cards descriptions” on page 32 for more information).

On-board ports

Three motherboard-mounted network interfaces are available for use, independent of those that may be included with interface cards mounted in *SLOTT 1*, *SLOTT 2*, or *SLOTT 3*. The motherboard-mounted ports are described in [table 7](#) (see appendix B, “Cabling” on page 149 for connection cable and appendix C, “Port pin-outs” on page 159 for pin-out data).

Table 7. SmartNode 2300 port description

Port	Description
SERIAL 0/0 (V.35 / X.21)	DB-25 socket providing a V.35 and X.21 interface for leased-lines at up to 2 Mbps. The <i>LINK</i> LED to the left of the connector indicates its status.
ETH 0/1 (10BaseT)	10Base-T Ethernet RJ-45 socket that connects the SmartNode with an Ethernet device, such as a wide area transmission modem, Ethernet hub, or switch. <i>ETH 0/1</i> is a host port; it can be connected with a straight-through wired cable to a hub, or a cross-over cable to a host port. The <i>LINK</i> LED is lit when the port is connected correctly to an active Ethernet device.
ETH 0/0 (10/100BaseT)	10/100Base-T Ethernet RJ-45 socket. The interface is similar in function to <i>ETH 0/1</i> except that it also supports 100Base-T. The <i>100Mb/s</i> LED is lit when the port is connected correctly to an active 100Base-T Ethernet device.
Console (RS-232)	RS-232 RJ-45 connector that connects the SmartNode with a serial terminal such as a PC or workstation with a RS-232 interface, with the following settings: <ul style="list-style-type: none"> • 9600 baud, no parity, 8 bit, 1 stop bit, 1 start bit • The console port is only used for service and maintenance



Do not plug in an ISDN connection. The voltage on the S-Bus may permanently damage the console interface.

In addition, two other elements—the *Reset* button and power input socket—are available on the rear panel of a SmartNode 1200 as described in [table 8](#).

Table 8. SmartNode 2300 Reset button and power line socket on rear panel

Element	Description
Reset button	<p>The button has three different functions:</p> <ul style="list-style-type: none"> • Manual Restart—During normal operation pressing and releasing the reset button will cause a system reboot. The application will be restarted without any change to the existing SmartWare configuration. • Restoration—Pressing and holding the reset button for 5 seconds will restore the factory configuration and automatically reboot the system. <p>Note In this case the existing IP SmartWare configuration is lost.</p> <ul style="list-style-type: none"> • Boot loader—Powering the SmartNode while pressing the reset button for 5 seconds will cause the factory-fitted boot loader to start in place of the application. The boot loader uses a minimal set of parameters. In case the application does not start correctly, the boot loader can be used as a fallback to download a new software version.
100–240 VAC 50/60 Hz	Electricity supply socket for mains power cable.

SmartNode 2400 description

The SmartNode Model 2400 (see [figure 11](#)) is a powerful multi-service access device. The 19-in. aluminum chassis can be rack-mounted, and provides three expansion slots for interface cards.

Note If you will be mounting the SmartNode 2400 in a 19-in. rack, see section “[Mounting the SmartNode 2400](#)” on page 103 for details.



Figure 11. Model 2400 (front and rear views shown)

Front panel

The SmartNode 2400 rear panel includes the *PWR*, *RUN*, and *ACT* LEDs that indicate the status of the device (see [figure 12](#)). See chapter 11, “[Monitoring Status](#)” on page 137 for detailed information on the LED states.



Figure 12. SmartNode 2400 front panel

See chapter 11, “[Monitoring Status](#)” on page 137 for more information on LED indications.

Rear panel

The SmartNode 2400 rear panel is depicted in [figure 13](#). There are four expansion slots for optional interface cards, and four board-mounted sockets. There are four expansion slots for optional interface cards, and four board-mounted sockets. The *Link*, and *100Mb/s* LEDs indicate the status of the Ethernet ports. See appendix B, “Cabling” on page 149 for connection cable and appendix C, “Port pin-outs” on page 159 for pin-out data.

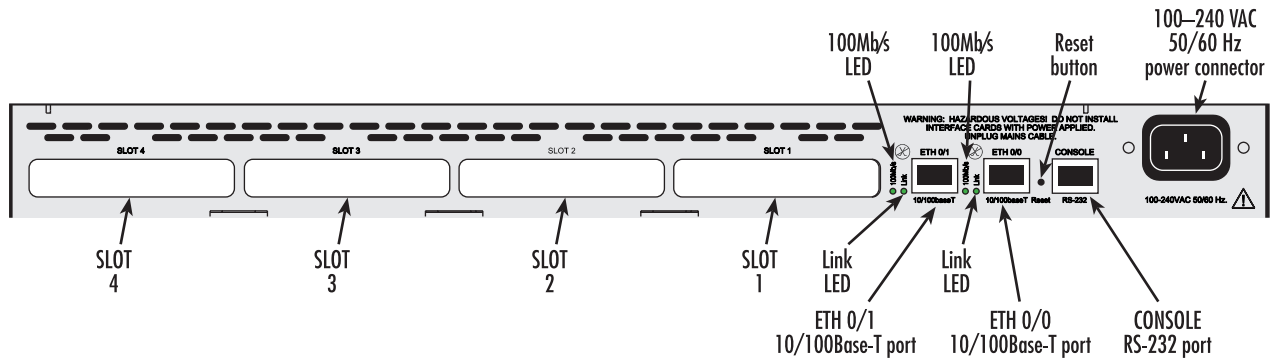

Figure 13. SmartNode 2400 rear panel

Expansion slots

The slots labeled *SLOT 1*, *SLOT 2*, *SLOT 3* and *SLOT 4* (see [figure 13](#)) accept different PMC interface cards to integrate voice and data over IP networks (see “Interface cards descriptions” on page 32 for more information).

On-board ports

Three motherboard-mounted network interfaces are available for use, independent of those that may be included with interface cards mounted in *SLOT 1*, *SLOT 2*, *SLOT 3*, or *SLOT 4*. The motherboard-mounted ports are described in [table 9](#) (see appendix B, “Cabling” on page 149 for connection cable and appendix C, “Port pin-outs” on page 159 for pin-out data).

Table 9. SmartNode 2400 port description

Port	Description
ETH 0/1 (10/100BaseT)	Ethernet RJ-45 socket that connects the SmartNode with an Ethernet device, such as a wide area transmission modem, Ethernet hub, or switch. <i>ETH 0/1</i> is a host port; it can be connected with a straight-through wired cable to a hub, or a cross-over cable to a host port. The <i>Link</i> LED is lit when the port is connected correctly to an active Ethernet device. The <i>100Mb/s</i> LED is lit when the port is connected correctly to an active 100Base-T Ethernet device.
ETH 0/0 (10/100BaseT)	Ethernet RJ-45 socket that connects the SmartNode with an Ethernet device, such as a wide area transmission modem, Ethernet hub, or switch. <i>ETH 0/0</i> is a host port; it can be connected with a straight-through wired cable to a hub, or a cross-over cable to a host port. The <i>Link</i> LED is lit when the port is connected correctly to an active Ethernet device. The <i>100Mb/s</i> LED is lit when the port is connected correctly to an active 100Base-T Ethernet device.

Table 9. SmartNode 2400 port description (Continued)

Port	Description
Console (RS-232)	RS-232 RJ-45 connector that connects the SmartNode with a serial terminal such as a PC or workstation with a RS-232 interface, with the following settings: <ul style="list-style-type: none"> • 9600 baud, no parity, 8 bit, 1 stop bit, 1 start bit • The console port is only used for service and maintenance



Do not plug in an ISDN connection. The voltage on the S-Bus may permanently damage the console interface.

In addition, two other elements—the *Reset* button and power input socket—are available on the rear panel of a SmartNode 2400 as described in [table 10](#).

Table 10. SmartNode 2400 Reset button and power line socket on rear panel

Element	Description
Reset button	The button has three different functions: <ul style="list-style-type: none"> • Manual Restart—During normal operation pressing and releasing the reset button will cause a system reboot. The application will be restarted without any change to the existing SmartWare configuration. • Restoration—Pressing and holding the reset button for 5 seconds will restore the factory configuration and automatically reboot the system. <p>Note In this case the existing IP SmartWare configuration is lost.</p> <ul style="list-style-type: none"> • Boot loader—Powering the SmartNode while pressing the reset button for 5 seconds will cause the factory-fitted boot loader to start in place of the application. The boot loader uses a minimal set of parameters. In case the application does not start correctly, the boot loader can be used as a fallback to download a new software version.
100–240 VAC 50/60 Hz	Electricity supply socket for mains power cable.



The mains supply *must* be secured with an external fuse or circuit-breaker, with a maximum tripping current of 16A.



Figure 14. SmartNode PMC interface cards

Interface cards descriptions

The following interface cards (see [figure 14](#)) are available for use with the SmartNode 2000 Series devices:

- IC-4FXS—Gateway interface card for 4 analog FXS ports (see page 32)
- IC-4BRV—8-channel gateway interface card for ISDN BRI (see page 33)
- IC-E1V—30-channel E1 gateway interface card for ISDN PRI (see page 40)
- IC-T1V—23-channel T1 gateway interface card for ISDN PRI (see page 41)

IC-4FXS Gateway interface card for 4 analog FXS ports

The IC-4FXS is a PMC standard compatible interface card for the SmartNode 2000 series. It provides 4 analog FXS ports and connects to the SmartNode base unit through a PCI packet and PCM circuit interface.

The IC-4FXS supports up to 4 simultaneous voice or fax calls. It is a flexible analog telephony card designed to meet the needs of small enterprises that want to connect their analog telephony equipment, such as an analog PBX or analog telephones, to a multi-service IP network.

The on-board dedicated micro-controller and DSPs off-load the CPU of the SmartNode 2000 series base unit enabling the conversion of voice/fax circuits into related IP-packets in real-time with minimal delay and jitter.

Front panel

The front view of the *IC-4FXS* interface card is depicted in [figure 15](#). The individual sockets are labeled on the bezel.

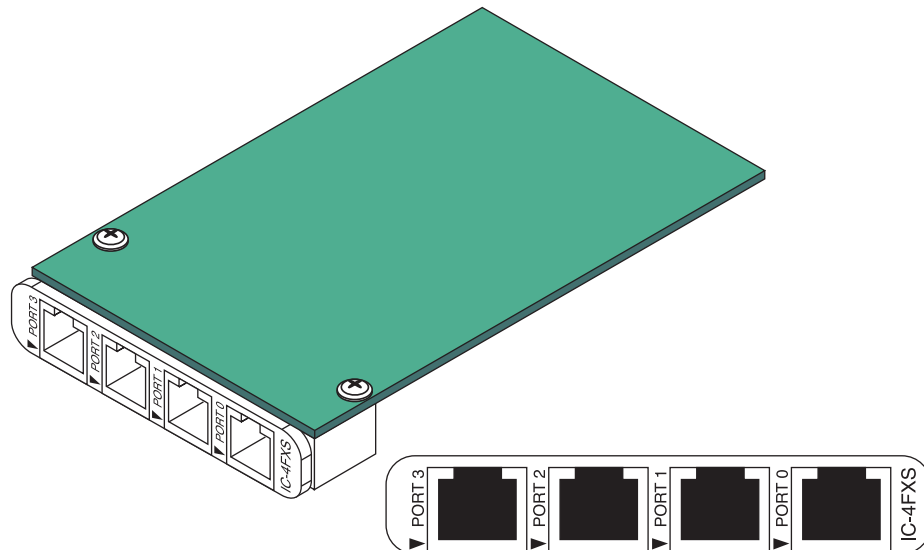

Figure 15. IC-4FXS

Ports

The card provides the four FXS ports whose details are tabulated in [table 11](#). Protector circuits protect the ports from high voltage surges. See appendix A, “[Specifications](#)” on page 145 for pin out data.

Table 11. IC-4FXS port description

Port	Description
0 ... 3	FXS RJ-11 socket to connect the SmartNode to an analog terminal (subscriber). Only two wires (Ring, Tip) are used. The 'Loop Start' method is used to signal whether the terminal is on- or off-hook (loop closed = on-hook).

Description

The IC-4FXS interface card provides four FXS ports, together allowing up to 4 analog voice channels to work in parallel.

Each ports provides the following the following:

- -48 VDC to the connected terminal
- Ring voltage to the connected terminal (normally 96 VAC at 25 Hz)
- On-hook transmission
- Caller identification (CLIP)
- Metering pulses
- Recognize dialed digits

The FXS ports must be connected to FXO ports.

Note When using the IC-4FXS, an internal line power module must be installed (see chapter 8, “[Line power module installation](#)” on page 115). This line power module provides the loop voltage (-48 VDC) and the input to the ring voltage generator.

IC-4BRV 8-channel gateway interface card for ISDN BRI

The IC-4BRV is a PMC standard compatible interface card for the SmartNode 2000 series. It provides 4 ISDN BRI interfaces and connects through a PCI packet and PCM circuit interface to the SmartNode base unit.

The IC-4BRV supports up to 8 simultaneous voice or fax calls. It is a flexible ISDN networking card designed to meet the needs of small enterprises that want to connect their ISDN equipment, such as an ISDN PBX, via multiple BRI interfaces to a multi-service IP network.

The ISDN interfaces can be configured as user or network side interfaces. Its on-board, dedicated micro-controller and DSPs off-load the CPU of the SmartNode 2000 base unit and hence guarantee the conversion of voice/fax circuits into related IP-packets in real-time with minimal delay and jitter values.

Front panel

The front view of the *IC-4BRV* interface card is depicted in [figure 16](#). The individual sockets are labeled on the bezel.

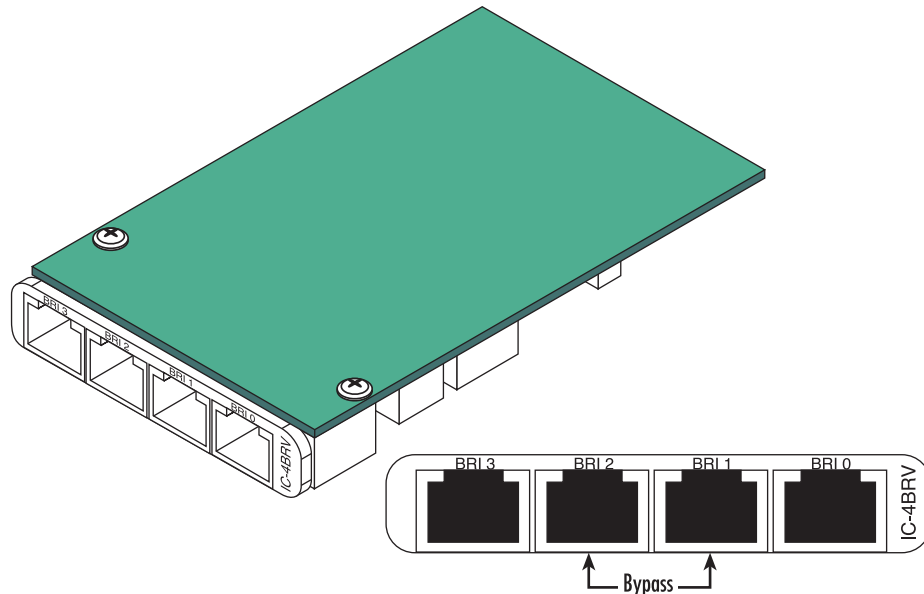

Figure 16. IC-4BRV

Ports

The card provides the four BRI ports whose details are tabulated in [table 12](#). Each one is terminated internally at 100 ohm. See appendix B, “[Cabling](#)” on page 149 for connection cable and appendix C, “[Port pin-outs](#)” on page 159 for pin-out data.

Table 12. IC-4BRV port description

Port	Description
BRI 0	ISDN BRI RJ-45 socket that connects the SmartNode with an ISDN terminal over an S or S/T interface.
BRI 1	ISDN BRI RJ-45 socket that connects the SmartNode with an ISDN terminal over an S or S/T interface. BRI 2 may be used as a fallback in conjunction with BRI 1. See ‘Hardware Bypass’ below.
BRI 2	ISDN BRI RJ-45 socket that connects the SmartNode with an ISDN device over an S or S/T interface. The pin out and protocol is software configurable. BRI 1 may be used as fallback in conjunction with BRI 2. See ‘Hardware Bypass’ below.
BRI 3	ISDN BRI RJ-45 socket that connects the SmartNode with an ISDN device over an S or S/T interface. The pin out and protocol mode is software configurable.

Description

The IC-4BRV interface card provides four ISDN basic rate interface (BRI) ports, together allowing up to 8 ISDN B-channels to work in parallel.

Operating modes

The four ports can be used in three different modes, which are tabulated in [table 13](#).

- An *X* in the *NET* column of the table means that the port performs network side signaling and that the pin out corresponds to an ISDN NT. A *NET* port is connected to an ISDN terminal, i.e. a telephone or a PBX.
- An *X* in the *USR* column means that the port performs user side signaling and the pin out corresponds to an ISDN terminal. The two ports (2, 3) have configurable pin outs.
- An *X* in the *HW Bypass* column refers to the fallback mode.

The possible BRI port configurations are listed in [table 13](#).

Table 13. BRI Port Configurations

Port	NET	USR	HW Bypass
BRI 0	X		
BRI 1	X		X
BRI 2	X	X	X
BRI 3	X	X	

Hardware bypass

BRI 1 and BRI 2 can be used to provide an emergency service. If a power failure occurs a relay connects these two interfaces with each other.

- BRI 1 must be connected with a telephone terminal or PBX if the bypass is active.
- BRI 2 must be connected to the ISDN network if the bypass is active.

Calls from an ISDN terminal are then automatically connected to the LE of the ISDN network. The bypass may also be activated manually. Figure 17 shows a typical fallback situation when the bypass is activated: the numbers in the boxes refer to the IC-4BRV's four BRI port numbers.

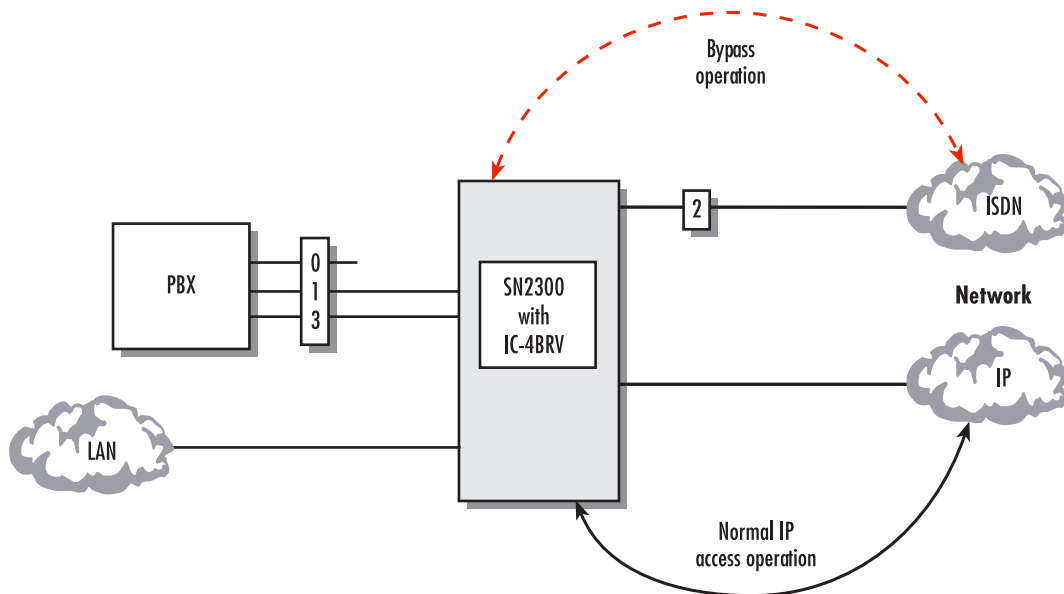

Figure 17. Bypass (fallback) mode

Network integration

With the configuration options tabulated above 4 BRI ports of the IC-4BRV can be connected in one of three network configurations:

- All four ports (ports 0–3) are connected to a subscriber PBX as shown in [figure 18](#) on page 37.
- Three ports (0, 1, 3) are connected to the PBX and one port (2) to the ISDN network (local breakout) as shown in [figure 19](#) on page 37. The local breakout port can be used to route calls from and to the ISDN network. This is the fallback situation described in section “[Hardware bypass](#)” on page 35. When power fails or the bypass is manually activated, ports 1 and 2 are inter-connected through the bypass relay, providing a lifeline to the ISDN network.
- Two ports (0, 1) are connected to the PBX and two ports (2, 3) to the ISDN network (see [figure 20](#) on page 38). In this case, both local breakout ports (four B-channels) can be used to route calls to the ISDN network. Only port 1 is protected by the bypass relay.

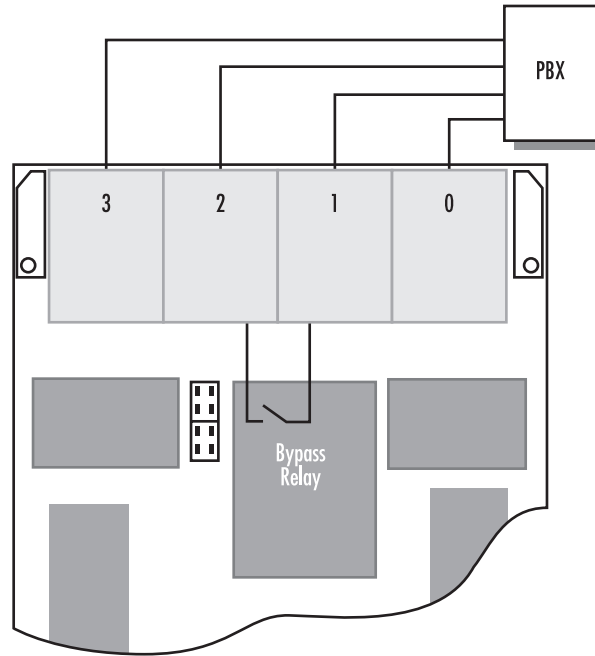

Figure 18. All four ports connected to PBX

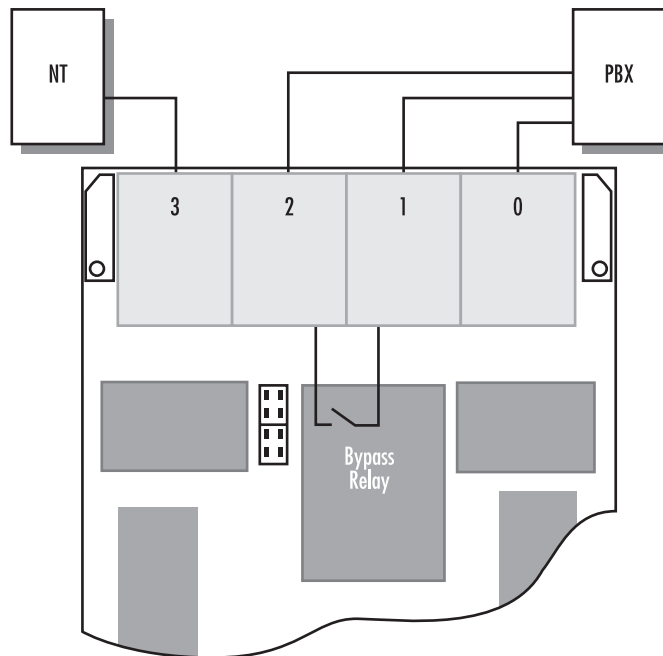

Figure 19. Three ports connected to the PBX and one port to the ISDN network

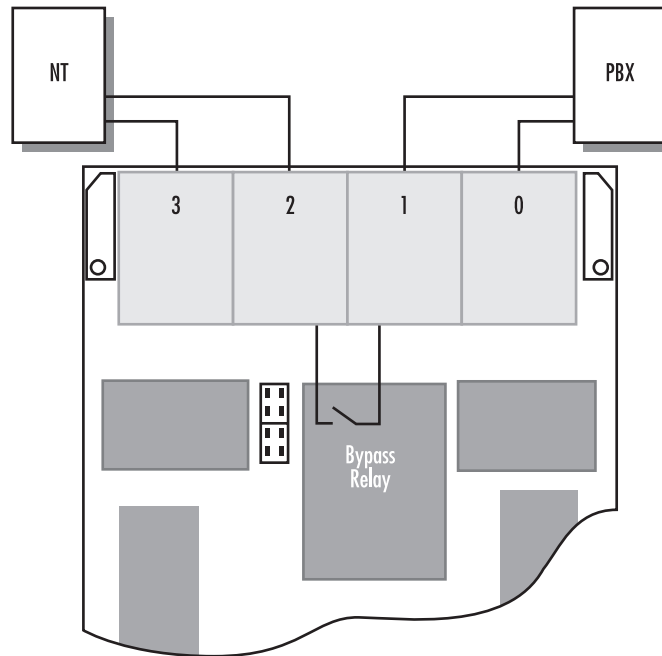

Figure 20. Two ports connected to the PBX and two ports to the ISDN network

S-Bus line power

Some ISDN terminals are powered through the S-Bus. This is usually the case for ISDN phones but not for PBXs. If you want to connect such a terminal directly to a port of the IC-4BRV, you must install a PM-48V-INT (or PM-40V-INT) power supply module. Two steps are required to provide S-Bus line power:

- Install an internal Line Power Module PM-48V-INT (or PM-40V-INT). This is described in section “[Internal PM-48V-INT or PM-40V-INT line power module installation](#)” on page 117.
- Configure the IC-4BRV card’s jumper settings. This procedure is described in the following paragraphs.

Line power jumper settings

A set of jumper pins determines how power is supplied to the BRI ports. The jumper pin block is located on the IC-4BRV interface card underside. See the series of illustrations, which follow.



When the line power module is installed and operating, ports 0 and 1 are always supplied with 40V power. Power output on ports 2 and 3 is configurable. You must not supply power to a port configured in *USR* mode, i.e. connected to an ISDN NT. Supply power only to those ports configured in *NET* mode where you want to connect line-powered terminals.

Note The jumpers are not accessible when the IC-4BRV card is installed, you must set the jumpers before installing the card in the SmartNode 2000 Series device.

Jumper settings for IC-4BRV and PM-48V-INT (or PM-40V-INT). The following are possible jumper settings for IC-4BRV and PM-48V-INT (or PM-40V-INT) fitted in SmartNode SmartNode 2000 Series:

- No jumpers are set: this setting is used with ports 2 and 3 configured in *USR* mode and connected to NTs as shown in [figure 21](#).
- Upper four jumper pins bridged: this setting is used with port 2 configured as fallback and connected to a NT as shown in [figure 22](#) on page 40.
- All eight jumper pins bridged: this setting is used with all four ports configured in *NET* mode and connected to line powered terminals as shown in [figure 23](#) on page 40.

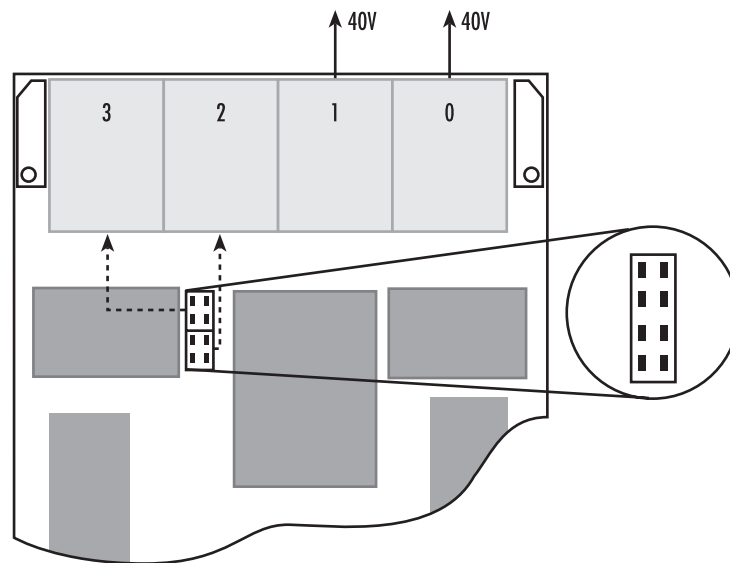

Figure 21. No jumpers set

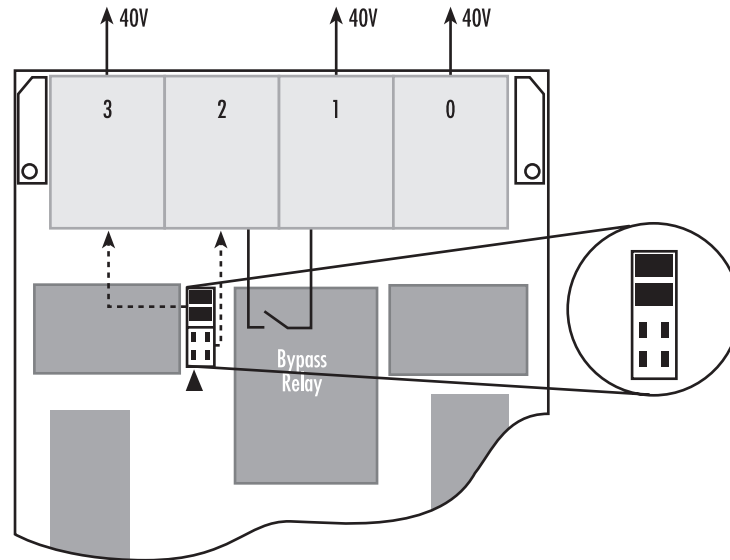

Figure 22. Upper four jumper pins bridged

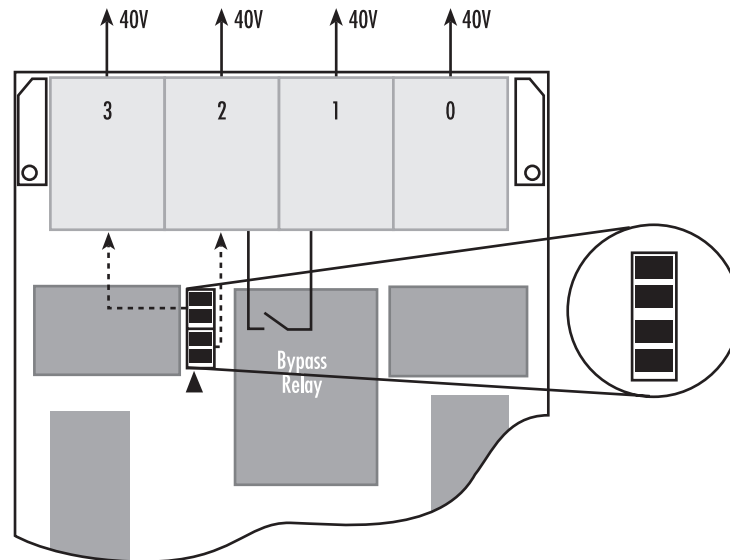

Figure 23. All eight jumper pins bridged

IC-E1V 30-channel E1 gateway interface card for ISDN PRI

The IC-E1V is a PMC standard compatible interface card for the SmartNode 2000 series. It provides one ISDN PRI interface and connects through a PCI packet and PCM circuit interface to the SmartNode base unit.

The IC-E1V is a high performance ISDN networking card that supports up to 30 simultaneous voice or fax calls. It meets the requirements of medium and large sized enterprises that want to connect their ISDN equipment, such as an ISDN PBX, via a PRI interface to a multi-service IP network.

The ISDN PRI interfaces can be configured as user or network side interfaces. Its on board dedicated micro-controller and DSPs off load the CPU of the SmartNode 2000 base unit and hence guarantee the conversion of voice/fax circuits into related IP-packets in real-time with minimal delay and jitter values

Front panel

The front view of the *IC-E1V* interface card is depicted in [figure 24](#). The *LINK* LED indicates the status of the interface. See chapter 11, “[Monitoring Status](#)” on page 137 on the LED states.

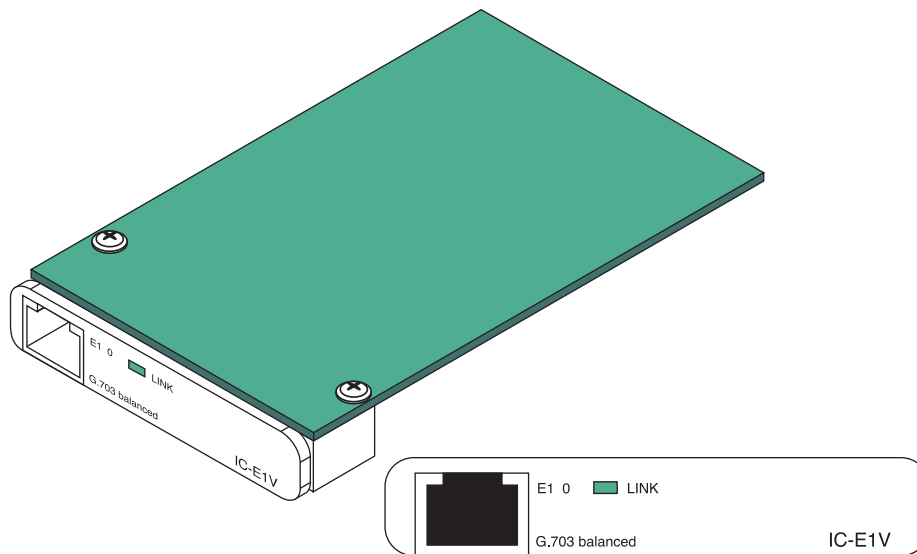

Figure 24. IC-E1V

Interface

The card provides one PRI port, described in [table 14](#). The connector is terminated at 120 ohm.

Table 14. IC-E1V port description

Port	Description
E1 0	RJ-45 connector providing E1 PRI (2.048 Mbps) interface, meeting all requirements of ITU-T recommendations for G.703. Use a shielded E1 interface cable for 120W balanced connections to connect the SmartNode with an NT or ET, e.g. a PBX or LE.

Description

The *IC-E1V* interface card provides an ISDN PRI interface allowing transfer of up to 30 ISDN voice channels in parallel.

Interface modes

The interface can be used in two different modes, namely NET or USR. The NET mode means the interface performs network-side signaling, whereas USR mode means user-side signaling as described in [table 15](#). For cabling, see [Appendix B on page 149](#).

Table 15. Interface modes

Task	NET Mode	USR Mode
Clocking Mode	Master: generates line clocking	Slave: accepts line clocking
Time Slot	Interface responsible for time slot selection	Interface accepts time slot selection

When changing the interface mode from *NET* to *USR*, or *USR* to *NET*, the clock source setting is automatically adjusted. For *NET* the clock becomes *master* and for *USR* the clock becomes *slave*.

You can manually override these default settings of the clock (refer to the *Software Configuration Guide*). The next time that the interface mode is changed the clock source changes back automatically to the default again.

IC-T1V 23-channel T1 gateway interface card for ISDN PRI

The IC-T1V is a PMC standard compatible interface card for the SmartNode 2000 series. It provides one ISDN PRI interface and connects through a PCI packet and PCM circuit interface to the SmartNode base unit.

The IC-T1V is a high performance ISDN networking card that supports up to 23 simultaneous voice or fax calls. It meets the requirements of medium and large sized enterprises that want to connect their ISDN equipment, such as an ISDN PBX, via a PRI interface to a multi-service IP network.

The ISDN PRI interfaces can be configured as user or network side interfaces. Its on board dedicated micro-controller and DSPs off load the CPU of the SmartNode 2000 base unit and hence guarantee the conversion of voice/fax circuits into related IP-packets in real-time with minimal delay and jitter values.

Front panel

The front view of the *IC-T1V* interface card is depicted in [figure 24](#). The *LINK* LED indicates the status of the interface. See chapter 11, “[Monitoring Status](#)” on page 137 for detailed information on the LED states.

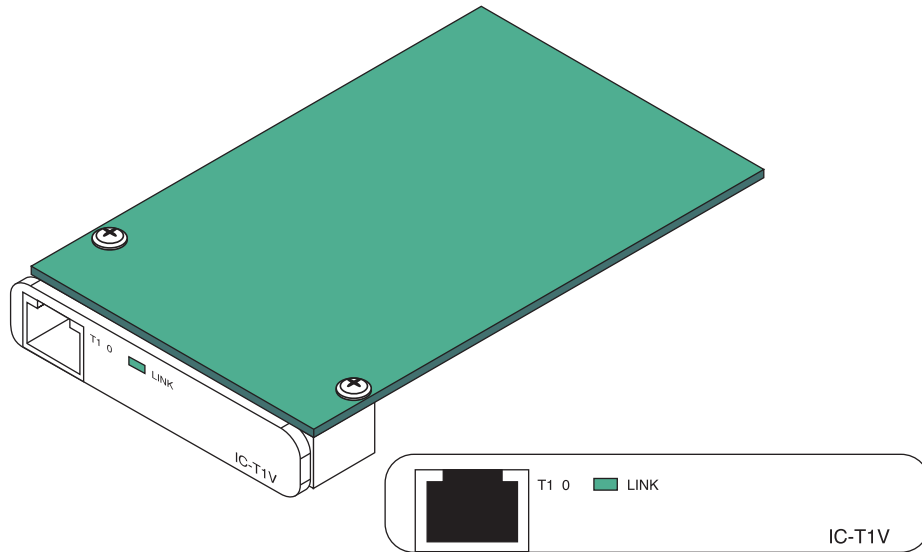

Figure 25. IC-T1V

Interface

The card provides one PRI port, described in [table 14](#). The connector is terminated at 120 ohm.

Table 16. IC-E1V port description

Port	Description
T1 0	RJ-45 connector providing T1 PRI (1.533 Mbps) interface, meeting all requirements of ITU-T recommendations for G.703. Use a shielded T1 interface cable for 120W balanced connections to connect the SmartNode with an NT or ET, e.g. a PBX or LE.

Description

The *IC-T1V* interface card provides an ISDN PRI interface allowing transfer of up to 23 ISDN voice channels in parallel.

Interface modes

The interface can be used in two different modes, namely *NET* or *USR*. The *NET* mode means the interface performs network-side signaling, whereas *USR* mode means user-side signaling as described in [table 15](#). For cabling, see [Appendix B on page 149](#).

Table 17. Interface modes

Task	NET Mode	USR Mode
Clocking Mode	Master: generates line clocking	Slave: accepts line clocking
Time Slot	Interface responsible for time slot selection	Interface accepts time slot selection

When changing the interface mode from *NET* to *USR*, or *USR* to *NET*, the clock source setting is automatically adjusted. For *NET* the clock becomes *master* and for *USR* the clock becomes *slave*.

You can manually override these default settings of the clock: see the documents *Software Configuration Guide*. The next time that the interface mode is changed the clock source changes back automatically to the default again.

Chapter 2 **Product Overview**

Chapter contents

Introduction	47
System model of the SmartNode 1000 and 2000 Series	48
Voice routing.....	48
SmartNode deployment.....	49
Customer premises gateway; multi-service providers	49
Small office or home office (SOHO)	49
Small and medium enterprise (SME)	50
Multi-service gateway/router for private enterprise networks	52
Company branch office	52
Company headquarters	53
IP access to the WAN	53
ISDN Gateway; LAN-based PBX or call center applications	54
LAN-based telephony gateways (GW)	54

Introduction

The SmartNode 1000 and 2000 series aggregate multiple channels of data and voice user-side traffic for transport over a single wide-area network (WAN) uplink. With one or more ISDN BRI or PRI interfaces, the SmartNode 1000 (see [figure 26](#)) and 2000 (see [figure 27](#)) series can be connected to an ISDN PBX or to a local exchange switch. Moreover, ISDN BRI interfaces can be used to attach ISDN telephones or to connect to an ISDN NT for voice call fallback or call routing to the PSTN.

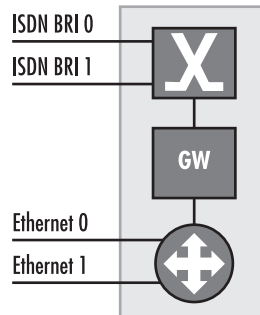

Figure 26. System model, SmartNode 1000 Series

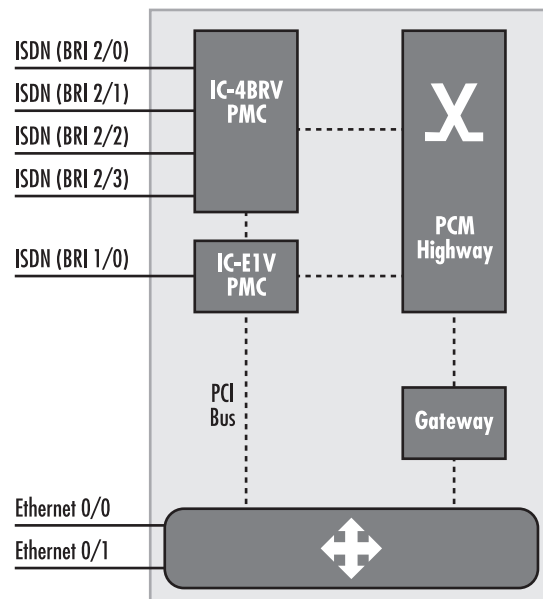

Figure 27. System model, SmartNode 2000 Series

Voice is transported as voice over Internet Protocol (VoIP) using the H.323 standards for sending and receiving audio and data or Patton Electronics' proprietary ISDN over Internet Protocol (ISoIP) on an IP-based network.

Since both of the Ethernet interfaces of a SmartNode 1000 and 2000 series are fully configurable, it is the application which defines whether an interface is used for WAN or LAN connections.

Depending of the deployment scenario, optional interface cards are available for the expansion slots of SmartNode 2000 series.

Note For information concerning hardware and interface card support see the SmartWare Software Release Notes for your Software Release and Build Number.

This chapter contains the following information about the SmartNode Series devices:

- System model of the SmartNode 1000 and 2000 Series
- Voice routing
- Overview of SmartNode deployment as a customer premises gateway supplied by a multi-service provider, a voice gateway and IP router, or a LAN voice gateway (see [page 49](#))

System model of the SmartNode 1000 and 2000 Series

The system model of Patton SmartNodes is depicted in [figure 26](#) and [figure 27](#) on page 47. The devices have three main components:

- ISDN switching, with two ISDN base rate interfaces (BRI).
- Gateway (GW), which converts ISDN voice data into Internet Protocol (IP) data streams or voice over IP (VoIP) and vice-versa. VoIP speech is supported according the H.323 standard and via Patton Networks' patented ISDN over IP (ISoIP) protocol.
- Router, with on-board Ethernet and other data interfaces which support *quality of service* (QoS) classes and *type of service* (TOS) bit setting. Quality of service enables the router to support multiple traffic classes.

Voice routing

Via its gateway, an Patton SmartNode 1000 and 2000 series device can carry voice data between the ISDN basic rate or primary rate interfaces and Ethernet or other data interfaces. This facility allows a wide variety of voice routing scenarios to be realized.

Small and medium enterprise (SME)

The SmartNode 1400 in [figure 29](#) is set up as a voice gateway and IP router in an SME situation. Both BRI ports are attached to a local PBX, offering up to four simultaneous voice channels to the IP access network that is connected to the Ethernet port ETH 0.

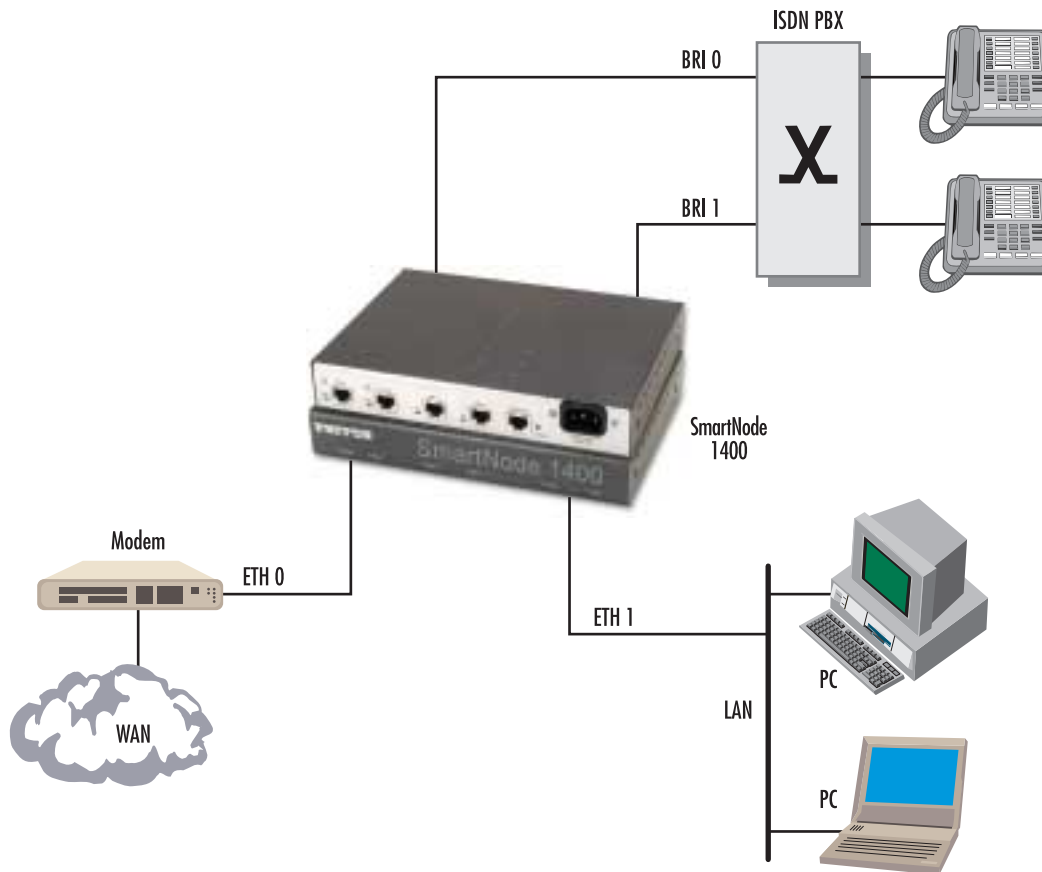

Figure 29. SmartNode 1400 attached to PBX via both ISDN BRIs in an SME environment

Figure 30 depicts a SmartNode 2000 series used as a voice gateway and IP router in an SME situation. The optional IC-4BRV interface card's BRI 2 port is used as an ISDN fallback interface. In case of a power failure, equipment connected to port BRI 1 is bypassed with a relay to interface BRI 2. It remains operational even if the SmartNode 2000 series is not powered. Three ports of the PBX are connected to the remaining BRI ports of the IC-4BRV interface card, providing up to six concurrent ISDN B-channels. The voice data is transferred via the integrated voice gateway in the SmartNode 2000 series over Ethernet port ETH 0/0. Depending on the call procedures defined by the software running in the SmartNode 2000 series, voice data is formatted as H.323 compliant or as ISoIP voice streams.

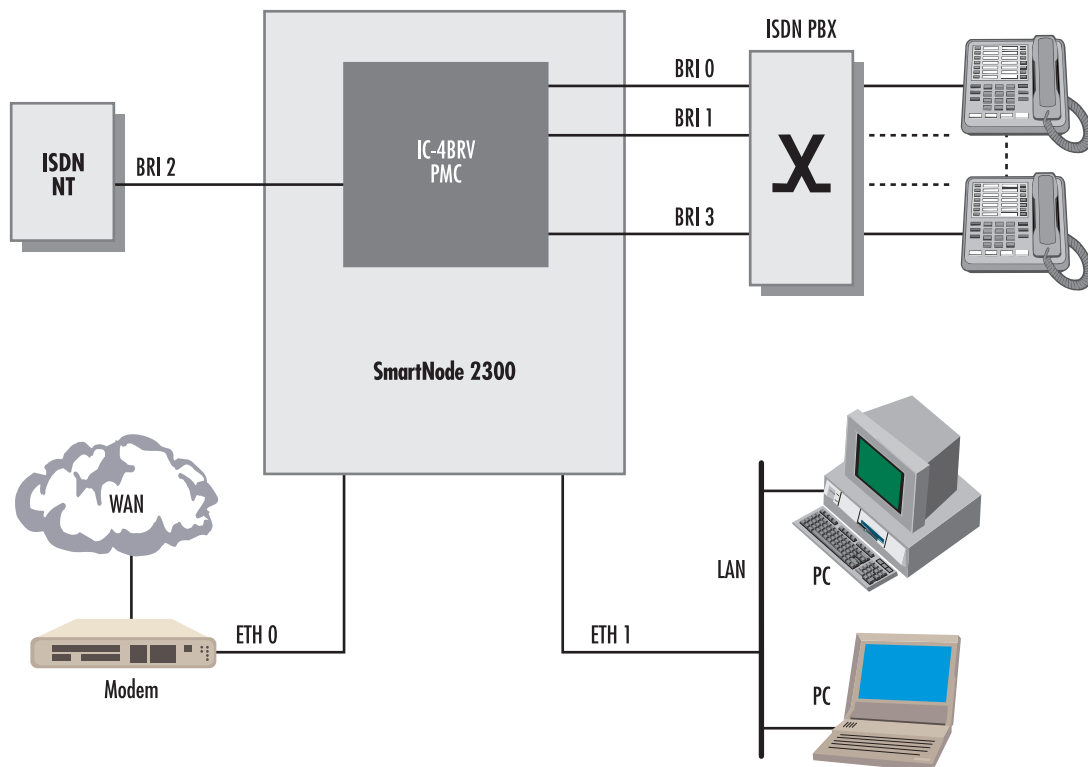

Figure 30. SmartNode 2000 Series device connected to a PBX via three BRI ports with fallback to PSTN with one BRI in an SME environment

Multi-service gateway/router for private enterprise networks

Company branch office

In figure 31 the SmartNode 2000 series with an optional IC-4BRV interface card installed is used as a voice gateway and IP router in a company branch office.

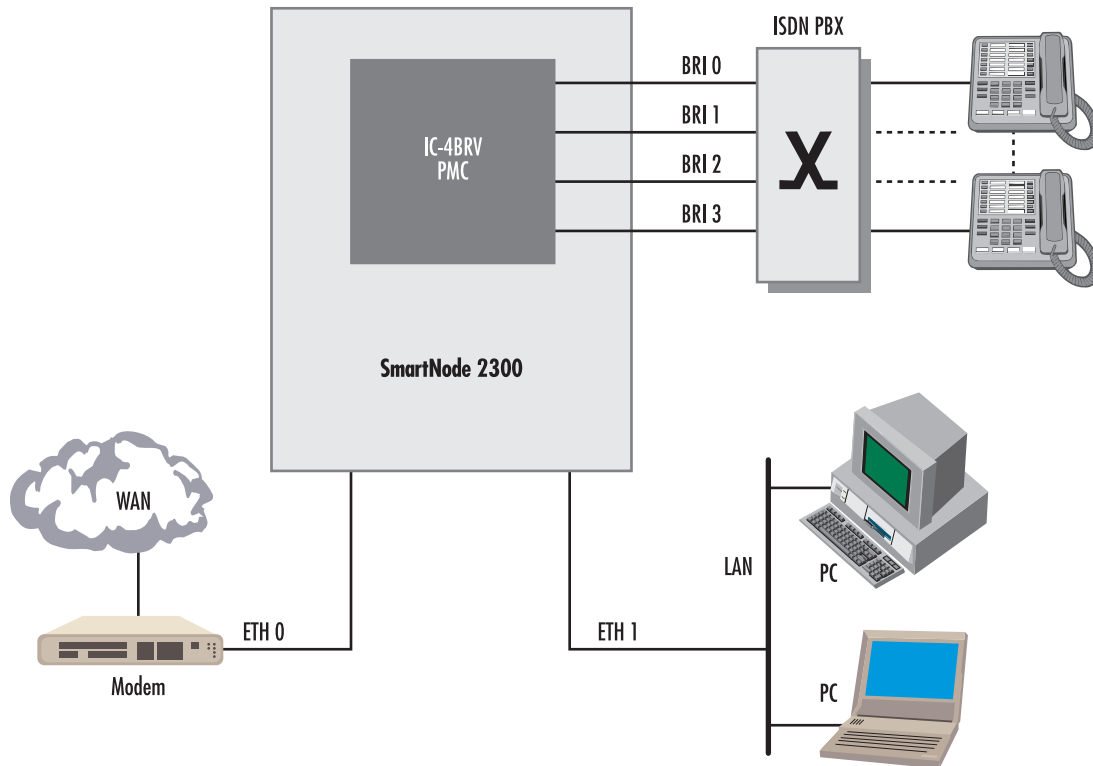

Figure 31. SmartNode 2000-Series device connected to a PBX via four BRI ports

The IC-4BRV interface card provides four ISDN BRI ports and is frequently used to interconnect existing ISDN PBXs over an IP network.

All four ports of the PBX are connected to the IC-4BRV interface card BRIs, providing a maximum of eight concurrent ISDN B-channels. The voice data is transferred via the integrated voice gateway in the SmartNode 2000 series via Ethernet port ETH 0/0. Depending on the call procedures defined by the software running in the SmartNode 2000 series, voice data is formatted as H.323 compliant or ISoIP voice streams.

Company headquarters

In [figure 32](#) the SmartNode 2000 series with an optional IC-E1V interface card installed is used as a voice gateway and IP router in a company headquarters.

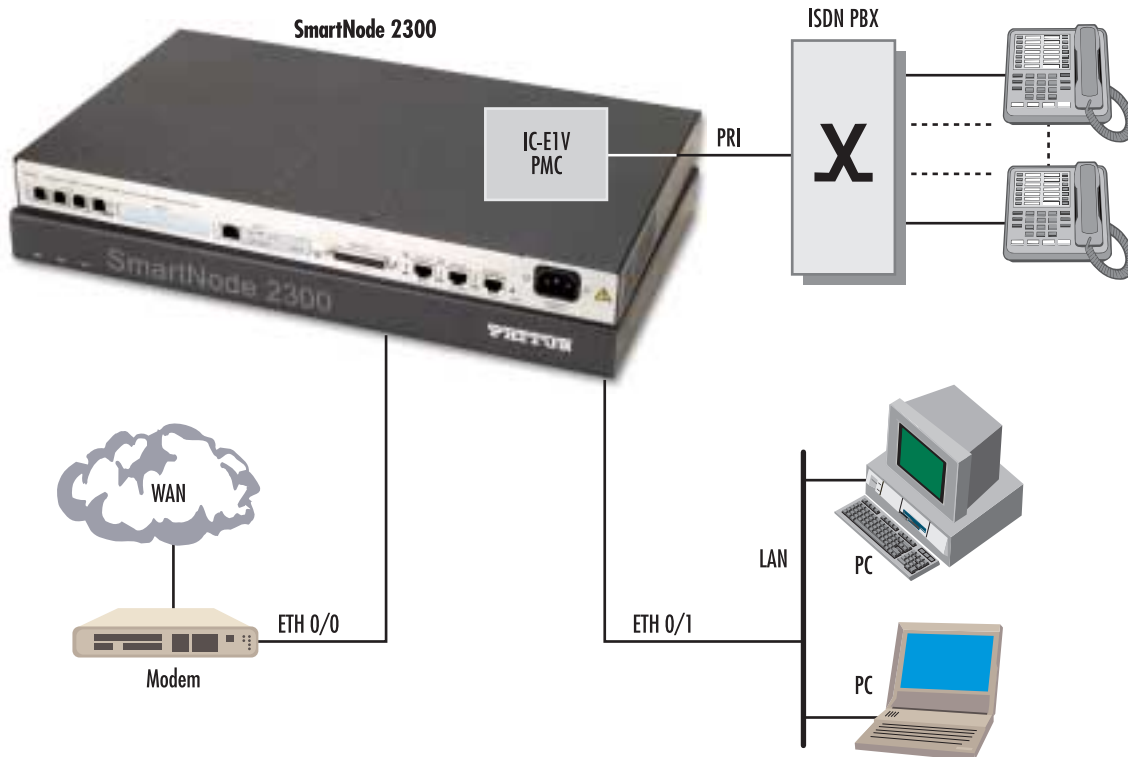

Figure 32. SmartNode 2000 Series device connected to a PBX via one PRI (with IC-E1V card) into an IP network

The PBX is connected to the PRI port of the IC-E1V interface card, providing up to 30 concurrent ISDN B-channels. The voice data is transferred via the integrated voice gateway in the SmartNode 2000 series over Ethernet interface ETH 0/0.

Depending on the call procedures defined by the software running in the SmartNode 2000 series, voice data is formatted as H.323 compliant or ISoIP voice streams.

IP access to the WAN

In the following figures, a wide-area transmission modem is shown as attached to the IP access network of the operator via Ethernet port ETH 0 for SmartNode 1000 series or ETH 0/0 for SmartNode 2000 series.

- [Figure 28](#) on page 49
- [Figure 29](#) on page 50
- [Figure 30](#) on page 51
- [Figure 31](#) on page 52
- [Figure 32](#) on page 53

Data traffic from the LAN attached to ETH 1 for SmartNode 1000 series or to ETH 0/1 for SmartNode 2000 series is routed to the WAN via Ethernet ports ETH 0 or ETH 0/0 respectively. Either standard IP routing or *network address port translation* (NAPT) can be configured on the SmartNode according to requirement.

ISDN Gateway; LAN-based PBX or call center applications

LAN-based telephony gateways (GW)

The SmartNode 1400 GW depicted in [figure 33](#) is utilized as a LAN voice gateway. On the local LAN that is shown connected to Ethernet port ETH 0, H.323 compliant voice applications are installed on hosts acting as H.323 terminals. An H.323 terminal is an endpoint in the network that provides for real-time, two-way communications with another H.323 terminal or gateway.

Outbound voice traffic is forwarded via the integrated voice gateway of the SmartNode 1400 to the PSTN. Inbound voice traffic from the PSTN is terminated on the respective host running the H.323 compliant client application according to the dialed calling number.

The H.323 gatekeeper is responsible for the translation of IP addresses into E.164 phone numbers (and phone numbers into IP addresses).

Note Hosts on the LAN need to be connected to Ethernet port ETH 0 using a hub.

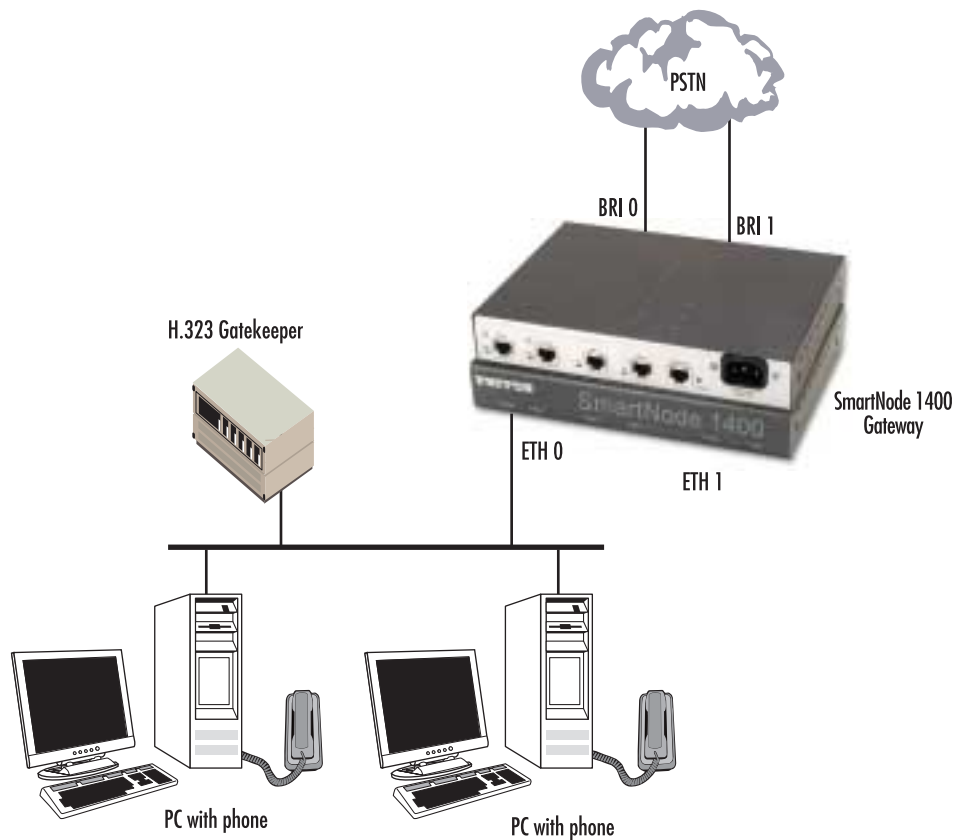

Figure 33. SmartNode 1400 GW used as LAN voice gateway with H.323 software clients on PCs and H.323 gatekeeper

Chapter 3 **Planning the installation**

Chapter contents

Introduction	57
Installation checklist	58
Site Log	58
Network information	59
Network diagram	59
IP related information	59
ISDN related information	59
S-Bus installation	59
SmartNode BRI port configured in USR mode and connected to an S-Bus	60
SmartNode BRI port configured in NET mode	60
Installing an S-Bus power supply	60
Synchronous serial interface	60
Software tools	61
Power source	61
Where to go next	61

Introduction

Before you start the actual installation, it is strongly recommended that you gather all the information needed to install and set-up the device. See section “[Installation checklist](#)” on page 58 for an example of what pre-installment checks you might need to carry out. Having carried out the pre-installation checks enables you to install and set up your SmartNode 1000 or 2000 series into an existing IP or an ISDN infrastructure with confidence.

Note The chapter covers a variety of SmartNode models that are similar in functionality but which differ in the number of interfaces that are supported. Therefore, some of the information provided may not apply to your particular SmartNode model.

Note When setting up your SmartNode consider cable length limitations, and potential electromagnetic interference (EMI) as defined by the applicable local and international regulations. Ensure that your site is properly prepared before beginning installation.

Before installing the SmartNode device, the following tasks should be completed:

- **Create a network diagram** (see section “[Network diagram](#)” on page 59)
- **Gather IP related information** (see section “[IP related information](#)” on page 59 for more information)
- **Collect ISDN related information** (see section “[ISDN related information](#)” on page 59)
- **Gather synchronous serial interface information** (SmartNode 2300 only) (see section “[Synchronous serial interface](#)” on page 60 for more information)
- **Install the hardware and software needed to configure the SmartNode.** (See section “[Synchronous serial interface](#)” on page 60)
- **Verify power source reliability** (see section “[Power source](#)” on page 61).

When you finish preparing for SmartNode installation, go to the appropriate section to install the device:

- Installing the SmartNode 1200 (see chapter 4, “[SmartNode 1200 installation](#)” on page 63)
- Installing the SmartNode 1400 (see chapter 5, “[SmartNode 1400 installation](#)” on page 75)
- Installing the SmartNode 2300 (see chapter 6, “[SmartNode 2300 installation](#)” on page 85)
- Installing the SmartNode 2400 (see chapter 7, “[SmartNode 2400 installation](#)” on page 101)

Installation checklist

The installation checklist in [table 18](#) lists the tasks for installing a SmartNode 1000 or 2000 series. Make a copy of this checklist and mark the entries as you complete each task. For each SmartNode 1000 or 2000 series, include a copy of the completed checklist in your site log.

Table 18. Installation checklist

Task	Verified by	Date
Network information available & recorded in site log		
Environmental specifications verified		
Site power voltages verified		
Installation site pre-power check completed		
Required tools available		
Additional equipment available		
All printed documents available		
SmartWare release & build number verified		
Rack, desktop, or wall mounting of chassis completed		
Initial electrical connections established		
ASCII terminal attached to console port		
Cable length limits verified		
Initial configuration performed		
Initial operation verified		

Site Log

Patton recommends that you maintain a site log to record all actions relevant to the system, if you do not already keep such a log. Site log entries might include information as listed in [table 19](#).

Table 19. Site log entries

Entry	Description
Installation	Make a copy of the installation checklist and insert it into the site log
Upgrades and maintenance	Use the site log to record ongoing maintenance and expansion history
Configuration changes	Record all changes and the reasons for them
Maintenance;	Schedules, requirements, and procedures performed
Comments	Notes, and problems
Software	Changes and updates to SmartWare software

Network information

Network connection considerations that you should take into account for planning are provided for several types of network interfaces are described in the following sections.

Network diagram

Draw a network overview diagram that displays all neighboring IP nodes, serial connected elements and ISDN components. It is recommended that you keep a copy in the site log (see “Site Log” on page 58 for more information on keeping a site log).

IP related information

Before you can set up the basic IP connectivity for your SmartNode 1000 or 2000 series you need to have the following information:

- IP addresses used for Ethernet LAN and WAN ports
- Subnet mask used for Ethernet LAN and WAN ports
- Lengths of Ethernet cables
- IP addresses of central H.323 gatekeeper
- IP addresses of central PSTN gateway for H.323 and/or ISoIP-based calls
- IP addresses of central TFTP server used for configuration upload and download

ISDN related information

To set up basic ISDN connectivity for your SmartNode 1000 or 2000 series you need to do or know the following:

- Check whether an additional line power is necessary and if an optional Phantom power supply or line power module needs to be installed
- Clock source for ISDN E1 interface
- Length of the ISDN S-Bus or E1 interface cables
- The block of sequential numbers assigned by your telecom operator that are used for the direct dial inwards (DDI) numbering plan to be used together with your PBX
- Define a multiple subscriber numbering (MSN) schema to give your individual endpoint a unique phone number that can be dialed directly
- Check whether an ISDN port is to be configured in USR (TE) or NET (NT) mode
- Check whether an ISDN port is to be configured as point-to-point or point-to-multipoint link

S-Bus installation

When installing an ISDN S-bus and up to eight connected devices, bear in mind that the relevant ITU-T, ETSI and ANSI standards for your equipment must be met. Your ISDN provider will help you to ensure that you comply with the relevant standards.

An S-Bus must be terminated at both ends with 100 ohm; such termination should be at the extreme ends of the bus.

Note Only the one device at the end should be terminated: SmartNode interfaces are internally terminated at 100 ohm.

It is recommended that a screened cable be used of a type that has been tested to at least ISO/IEC 11801 Category 3.

According to ITU-T the maximum length of flex connecting the bus with terminal equipment may not exceed 33 feet (10 meters). Some ISDN providers or devices may require a lesser distance, so consult your suppliers. In accordance with ITU-T the maximum length of the S-bus depends on the delay constant of the cable. If this is too great, the time sequence of the equipment signals attached to it may be corrupted. The maximum distance between NT1 and TE is theoretically 656 feet (200 meters), but in practice 492 feet (150 meters) is the usual maximum.

SmartNode BRI port configured in USR mode and connected to an S-Bus

The SmartNode acts as TE on the S-Bus: usually no other TE are connected on the S-Bus between the NT1 and the SmartNode. The general S-Bus conditions apply, the maximum recommended bus length is 492 feet (150 meters).

Note SmartNode BRI interfaces are internally terminated at 100 ohms.

SmartNode BRI port configured in NET mode

The SmartNode acts as NT1. The general S-Bus conditions apply, the maximum recommended bus length is 492 feet (150 meters).

Note SmartNode BRI interfaces are internally terminated at 100 ohms.

Installing an S-Bus power supply

If your SmartNode 2000 series needs to be equipped with an optional line power module refer to chapter 8, “[Line power module installation](#)” on page 115 for a more detailed description of this procedure. Check that the jumper pins are correctly set for your method of using the IC-4BRV interface card (see section “[IC-4BRV 8-channel gateway interface card for ISDN BRI](#)” on page 33).

Synchronous serial interface

The SmartNode 2300 supports the V.35 and X.21 standard for synchronous serial interfaces at speeds up to 2 Mbps. Devices that communicate over a serial interface are divided into two classes:

- Data terminal equipment (DTE): the device at the user end of the user-to-network interface. The DTE connects to a data network via data DCE, and typically uses clocking signals generated by the DCE.
- Data communications equipment (DCE): the device at the network end of the user-to-network interface. The DCE provides a physical connection to the network, forwards traffic, and provides a clocking signal used to synchronize data transmission between DCE and DTE devices.

The most important difference between these two types of device is that the DCE device supplies the clock signal that paces the communications on the interface.

Note A SmartNode 2300 functions as a DTE.

The synchronous serial port is labeled *SERIAL 0/0* on the SmartNode 2300. Before you connect a device to it you need to check the following:

- Confirm that the device that you are connecting the SmartNode to is a DCE that provides a clock signal on the synchronous serial port
- Type of connector, male or female, required when connecting to the device port
- Signaling protocol; the device requires X.21 or V.35

Software tools

You will need a PC computer with HyperTerminal or equivalent VT-100 emulation program, or an ASCII terminal (also called a *dumb terminal*) to configure the software on your SmartNode device.

Power source

If you suspect that your AC power is not reliable, for example if room lights flicker often or there is machinery with large motors nearby, have a qualified professional test the power. Install a power conditioner if necessary.

Where to go next

When you finish preparing for SmartNode installation, go to the appropriate section to install the device:

- Installing the SmartNode 1200 (see chapter 4, “[SmartNode 1200 installation](#)” on page 63)
- Installing the SmartNode 1400 installation (see chapter 5, “[SmartNode 1400 installation](#)” on page 75)
- Installing the SmartNode 2300 installation (see chapter 6, “[SmartNode 2300 installation](#)” on page 85)
- Installing the SmartNode 2400 installation (see chapter 7, “[SmartNode 2400 installation](#)” on page 101)

Chapter 4 **SmartNode 1200 installation**

Chapter contents

Hardware installation	65
Mounting the SmartNode 1200	65
Desktop installation	65
Wall-mounted installation	66
Connecting cables.....	67
Installing the Ethernet cables	67
Installing the BRI cables	68
External S-Bus power supply	70
Installing the power cord	73

Hardware installation

SmartNode 1200 installation consists of the following:

- Placing the device at the desired installation location (see section “Mounting the SmartNode 1200” on page 65)
- Installing the interface and power cables (see section “Connecting cables” on page 67)

When you finish installing the SmartNode 1200, go to chapter 10, “Getting Started with the SmartNode Device” on page 129.

Mounting the SmartNode 1200

The SmartNode 1200 should be placed in a dry environment with sufficient space to allow air circulation for cooling.

Note For proper ventilation, leave at least 2 inches (5 cm) to the left, right, front, and rear of the SmartNode 1200.

The SmartNode 1200 can be installed as follows:

- Placed on a desktop or similar sturdy, flat surface that offers easy access to the cables
- Mounted on a wall

Desktop installation

Do the following to install the SmartNode 1200:

1. Remove one of the rubber pads from the adhesive strip (included in the SmartNode installation kit pack) and place it on a corner on the bottom of the SmartNode 1200 (see [figure 34](#)).

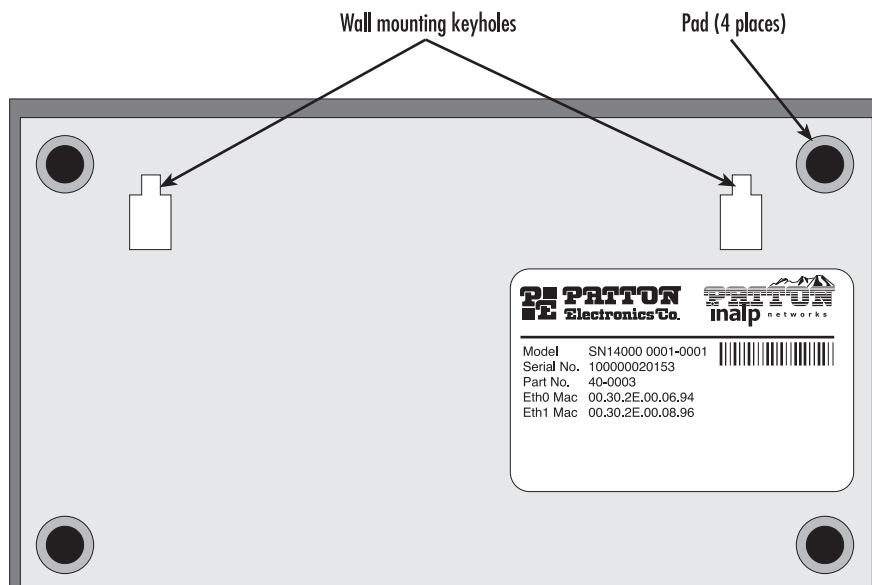

Figure 34. Pads and wall-mounting keyholes locations

- Repeat step 1 to install pads on the remaining three corners on the bottom of the SmartNode 1200.
- Place the unit on a desktop, shelf or other flat, hard, and secure surface.

Note Allow sufficient space at the rear of the chassis for cable connections. In addition you should consider the need to access the chassis for future upgrades, maintenance and troubleshooting. Multiple SmartNodes can be stacked one atop the other.

Wall-mounted installation

Do the following to install the SmartNode 1200:

- Using [figure 35](#) as a guide, determine the positions of the mounting holes on the wall and mark the locations of the mounting holes.

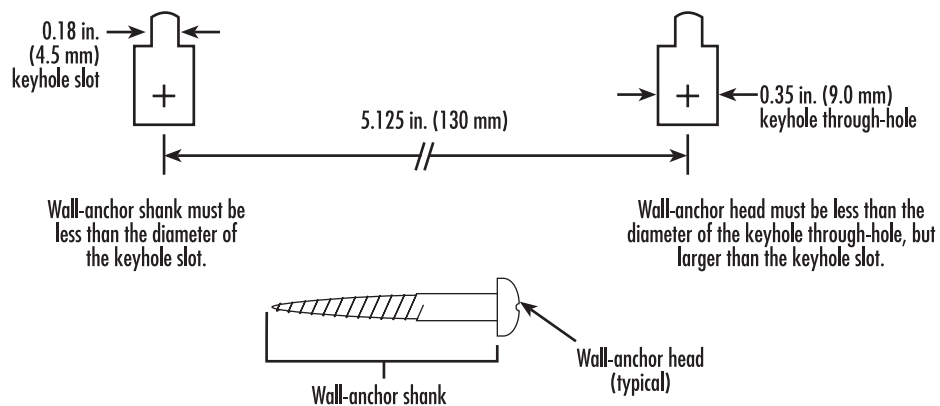

Figure 35. Wall-mounting hole dimensions

Note Mounting hardware is not provided. The installer must determine which fastener is appropriate for that particular application.

- Install the (user-provided) wall anchors. Any standard anchoring method may be used, such as wood screws; butterfly anchors/molly bolts (for installation into a sheetrock/drywall or plasterboard surface); or expansion bolts (for installation into a concrete or masonry surface). The anchor screw heads must have just enough clearance to allow the wall-mounting key holes (see [figure 34](#) on page 65) to slip onto them when hanging the SmartNode 1200.
- Hang the SmartNode 1200 on the wall-anchor mounting screws.

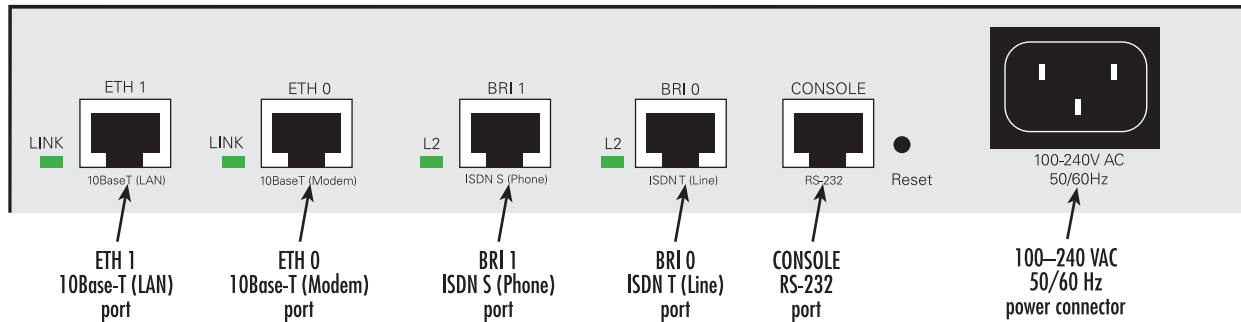

Figure 36. SmartNode 1200 connectors

Connecting cables

Installing SmartNode 1200 cables takes place in the following order:



Do not work on the system or connect or disconnect cables during periods of lightning activity.

1. Installing the 10Base-T Ethernet cable into ports *ETH 0* and *ETH 1* (see [figure 36](#)) (see “[Installing the Ethernet cables](#)” on page 67).
2. Installing the BRI 0 and BRI 1 cables (see “[Installing the BRI cables](#)” on page 68).
3. Installing the power cord (see “[Installing the power cord](#)” on page 73).

Installing the Ethernet cables

Ethernet devices (10Base-T) are connected to the SmartNode’s Ethernet ports (see [table 20](#) for port pin-out listing) via a cable terminated with RJ-45 plugs. Use a cross-over cable to connect to a host (see [figure 37](#) on page 68), or a straight-through cable to connect to a hub (see [figure 38](#) on page 68).

Table 20. Ethernet 10Base-T (RJ-45) port pin-outs

Pin	Signal
1	TX+
2	TX-
3	RX+
6	RX-

Note Pins not listed are not used.

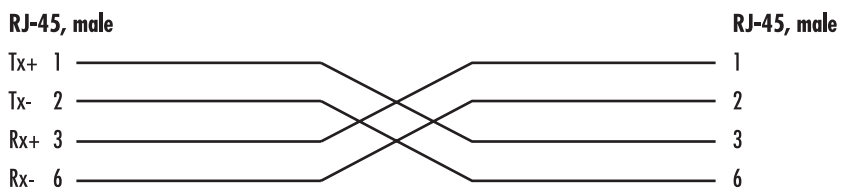
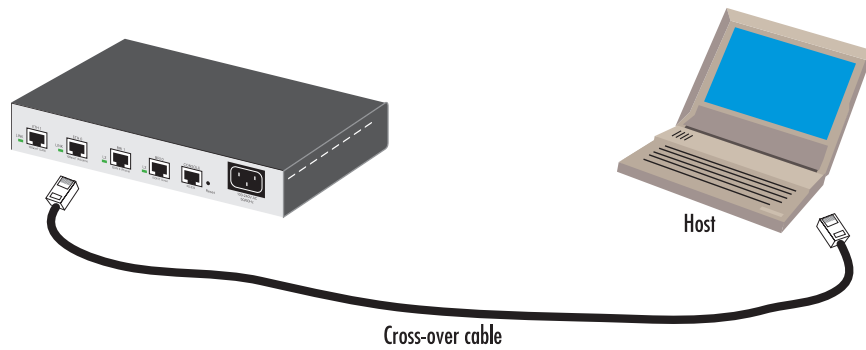

Figure 37. Connecting to a host

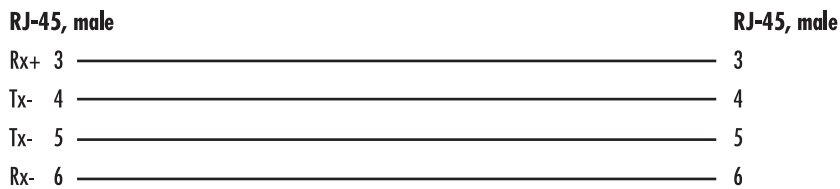
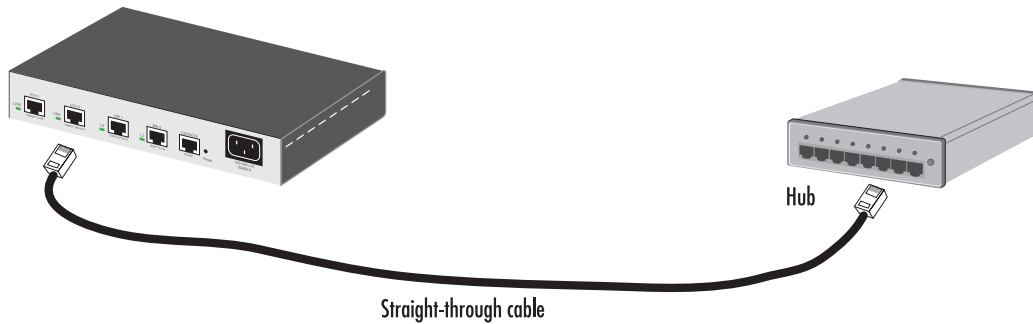

Figure 38. Connecting to a hub

Installing the BRI cables

A straight-through S-Bus cable terminated with RJ-45 plugs is used to connect an ISDN NT or TE to the SmartNode 1200 BRI ports (see [table 21](#) for port pin-out listing). If you are connecting a BRI to an ISDN

telephone, see [figure 39](#), or see [figure 40](#) on page 70 if you are connecting a BRI to an NT. For BRI ports with configurable pin outs ensure that the appropriate mode (NET or USR) is configured.

Table 21. BRI (RJ-45) port pin-outs

Pin	Signal (USR)	Signal (NET)
3	TX+	RX+
4	RX+	TX+
5	RX-	TX-
6	TX-	RX-

Note Pins not listed are not used.



Hazardous network voltages are present in the BRI cables. If you detach the cable, detach the end away from the SmartNode or interface card first to avoid possible electric shock. Network hazardous voltages may be present on the device in the area of the BRI port, regardless of when power is turned OFF.



To prevent damage to the system, make certain you connect the BRI cable to the BRI port only and not to any other RJ-45 socket.

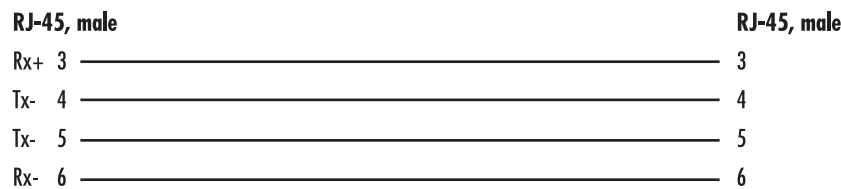
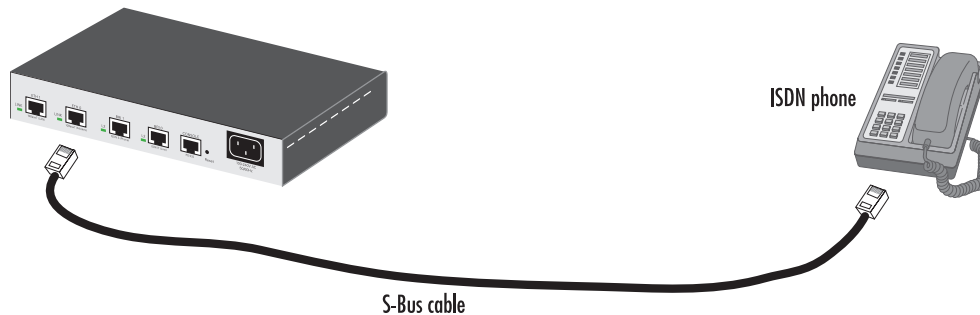

Figure 39. Connecting a BRI to an ISDN telephone

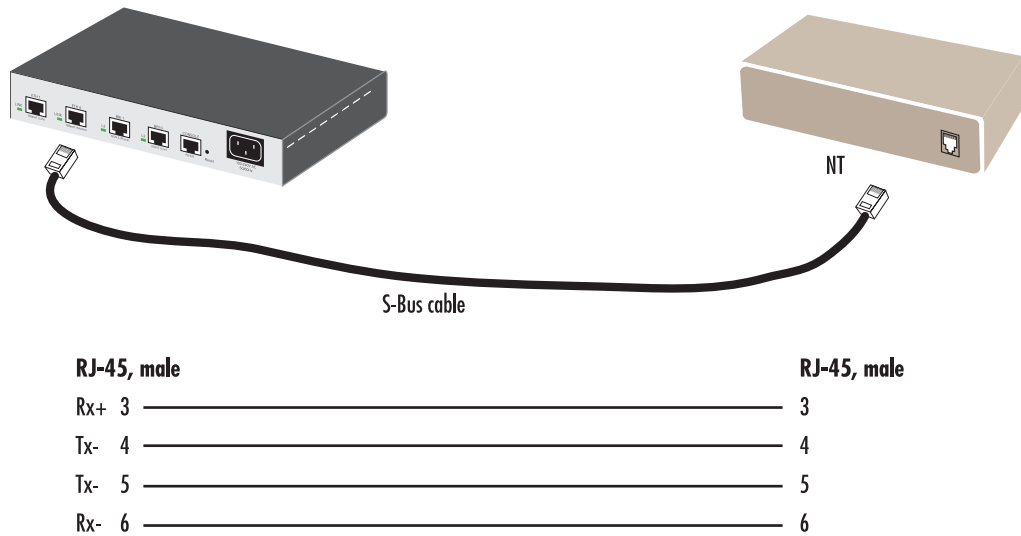

Figure 40. Connecting a BRI to an NT

External S-Bus power supply

Many ISDN telephone handsets require that 40-VDC power be supplied via the S-Bus connection. In other words, they have no separate or built-in power supply. In general, point-to-multipoint ISDN BRI NTs supply line power to the S-Bus. Point-to-point NTs connected to a PBX generally do not supply line power.

The SmartNode 1200 does not supply S-Bus line power on the BRI ports, however, there are two options to provide S-Bus line power:

- If one of the BRI ports is connected to an ISDN NT, the power supplied by the NT is fed through to the other BRI port.
- If line power is not available from the NT, but required for connected terminals, the PM-BRI-EXT S-Bus Phantom power supply can be used.

Table 22. PM-BRI-EXT S-Bus 40V power supply

Item	Phantom Power Supply; PM-BRI-EXT
Voltage Specifications	Input 230VAC, Output 40VDC



The PM-BRI-EXT power supply unit is equipped with a transformer that is specially designed for S-Bus line power. The use of a general purpose DC power transformer may cause equipment damage.



If you use a Phantom power supply other than that supplied by Patton Electronics Co., you must ensure that it conforms to ITU I.430 Section 9.7.3.2.2. which specifies that the maximum current delivered shall not exceed 200mA.

Note The following installation options are available:

- In the absence of an NT the PM-BRI-EXT may be connected directly to the BRI 0 port on the SmartNode (see [figure 41](#)). The terminals are connected to the BRI 1 port.
- The PM-BRI-EXT is connected to the S-Bus via an S-Bus multi-socket (see [figure 42](#) on page 72).



Do not plug the Phantom power supply directly into any other port than BRI 0. Installing it on the Ethernet ports or Console port could result in serious equipment damage.

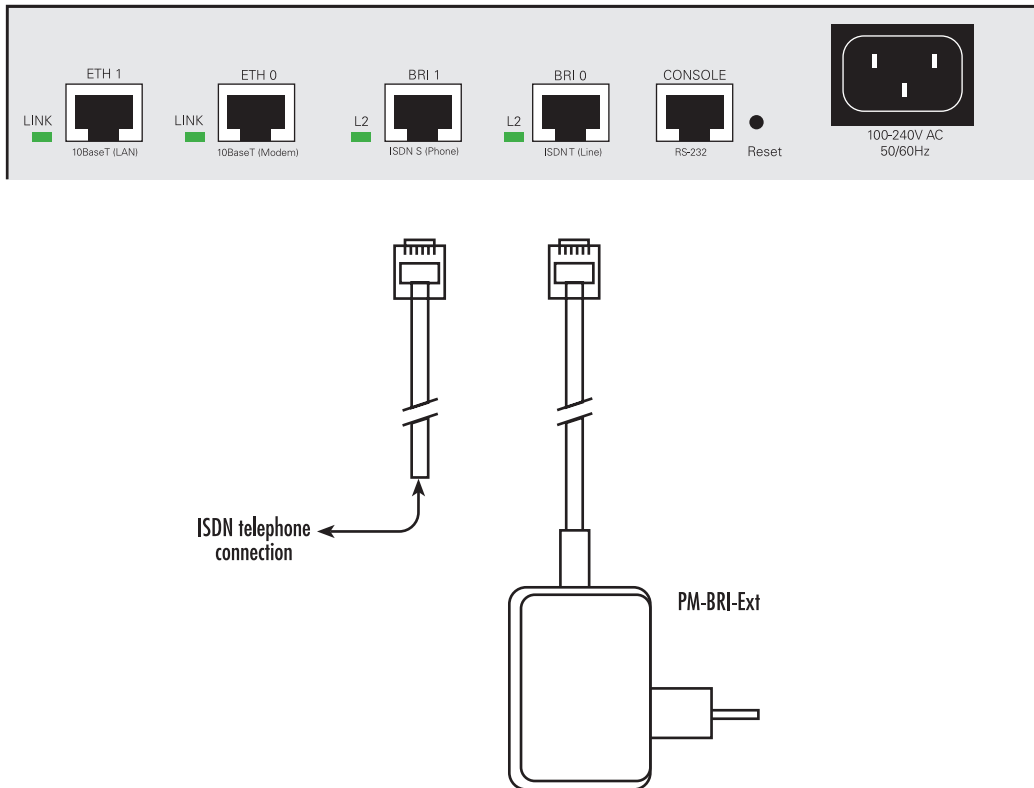

Figure 41. SmartNode 1200 external 40-VDC power supply

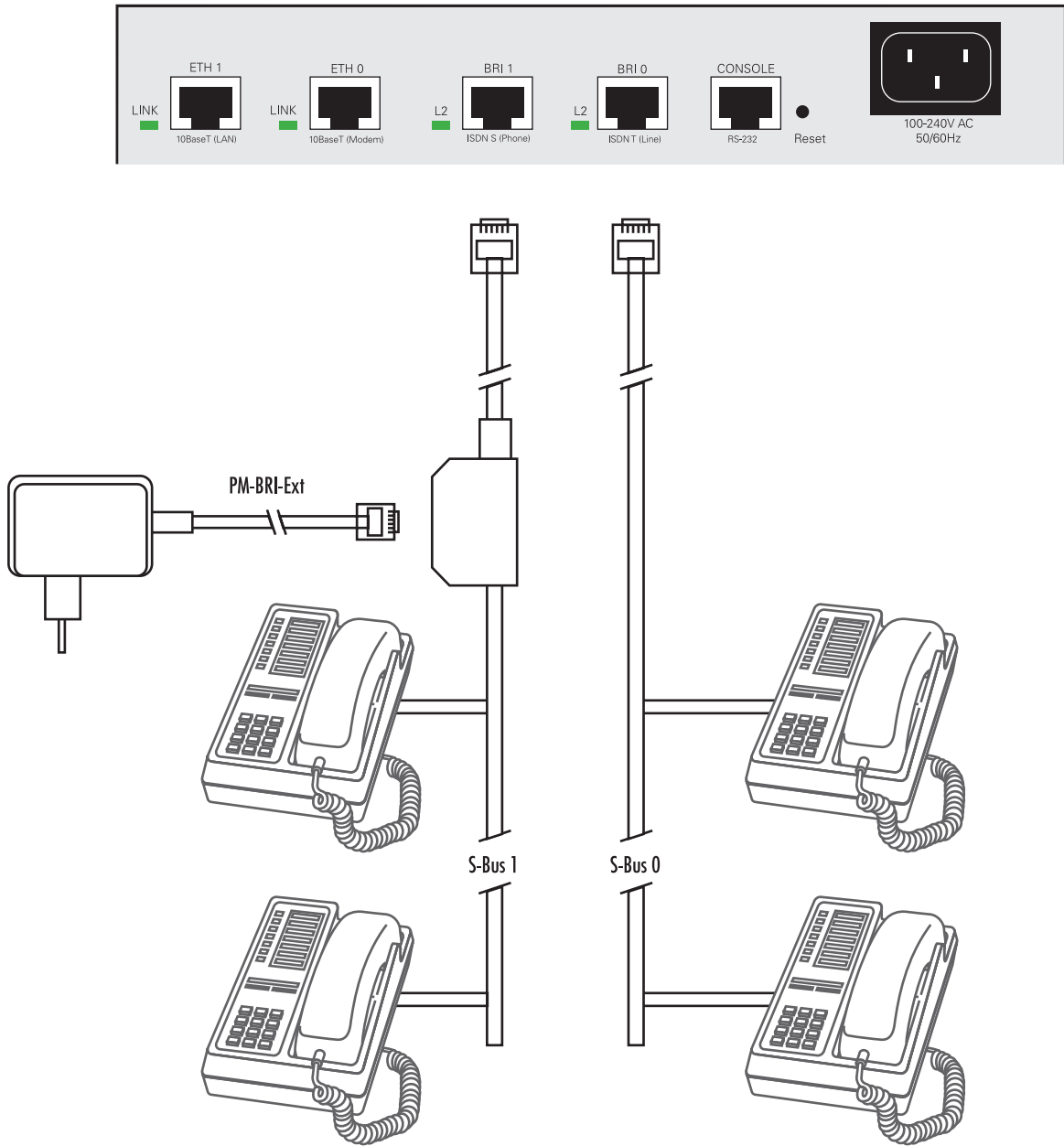

Figure 42. SmartNode 1200 external 40-VDC power supply

Installing the power cord

Do the following:

1. Insert the barrel type connector end of the AC power cord into the 100–240 VAC power connector (see [figure 36](#)).



The SmartNode 1200 power supply automatically adjusts to accept an input voltage from 100 to 240 VAC (50/60 Hz).

Verify that the proper voltage is present before plugging the power cord into the receptacle. Failure to do so could result in equipment damage.

Note *Do not connect the other end of the power cord to the power outlet at this time.*

2. Verify that the AC power cord included with your router is compatible with local standards. If it is not, refer to chapter 12, “[Contacting Patton for assistance](#)” on page 141 to find out how to replace it with a compatible power cord.
3. Connect the male end of the power cord to an appropriate power outlet.
4. Verify that the green *Power* LED is lit (see [figure 43](#)).
5. Unplug the power cord from the router to power down the unit.

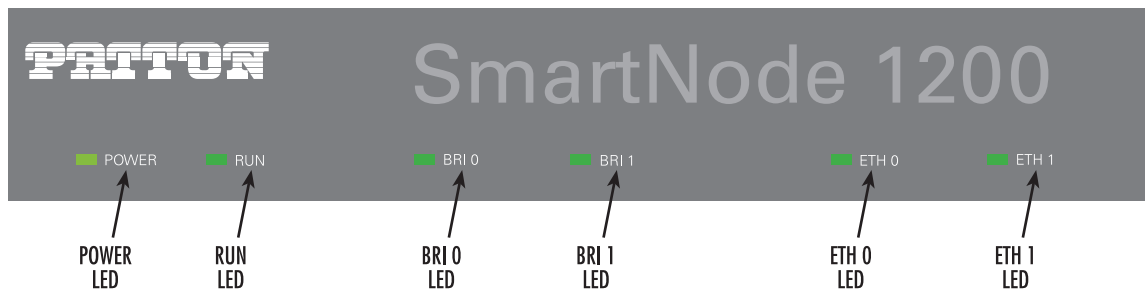

Figure 43. SmartNode 1200 front panel LEDs

Congratulations, you have finished installing the SmartNode 1200! Now go to chapter 10, “[Getting Started with the SmartNode Device](#)” on page 129.

Chapter 5 **SmartNode 1400 installation**

Chapter contents

Hardware installation	77
Mounting the SmartNode 1400	77
Desktop installation	77
Wall-mounted installation	78
Connecting cables.....	79
Installing the Ethernet cables	79
Installing the BRI cables	80
External S-Bus power supply	82
Installing the power cord	84

Hardware installation

SmartNode 1400 installation consists of the following:

- Placing the device at the desired installation location (see section “Mounting the SmartNode 1400” on page 77)
- Installing the interface and power cables (see section “Connecting cables” on page 79)

When you finish installing the SmartNode 1400, go to chapter 10, “Getting Started with the SmartNode Device” on page 129.

Mounting the SmartNode 1400

The SmartNode 1400 should be placed in a dry environment with sufficient space to allow air circulation for cooling.

Note For proper ventilation, leave at least 2 inches (5 cm) to the left, right, front, and rear of the SmartNode 1400.

The SmartNode 1400 can be installed as follows:

- Placed on a desktop or similar sturdy, flat surface that offers easy access to the cables
- Mounted on a wall

Desktop installation

Do the following to install the SmartNode 1400:

1. Remove one of the rubber pads from the adhesive strip (included in the SmartNode installation kit pack) and place it on a corner on the bottom of the SmartNode 1400 (see figure 44).

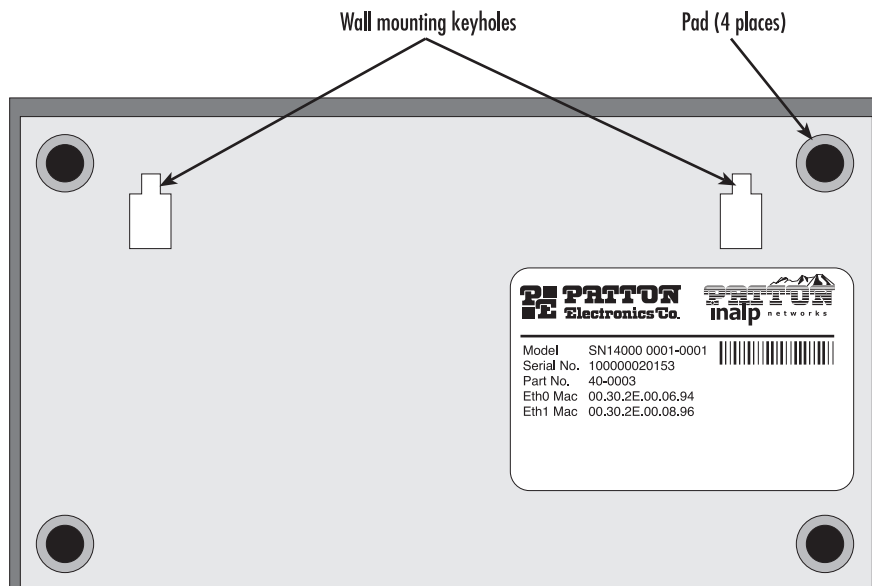

Figure 44. Pads and wall-mounting keyholes locations

2. Repeat step 1 to install pads on the remaining three corners on the bottom of the SmartNode 1400.
3. Place the unit on a desktop, shelf or other flat, hard, and secure surface.

Note Allow sufficient space at the rear of the chassis for cable connections. In addition you should consider the need to access the chassis for future upgrades, maintenance and troubleshooting. Multiple SmartNodes can be stacked one atop the other.

Wall-mounted installation

Do the following to install the SmartNode 1400:

1. Using [figure 45](#) as a guide, determine the positions of the mounting holes on the wall and mark the locations of the mounting holes.

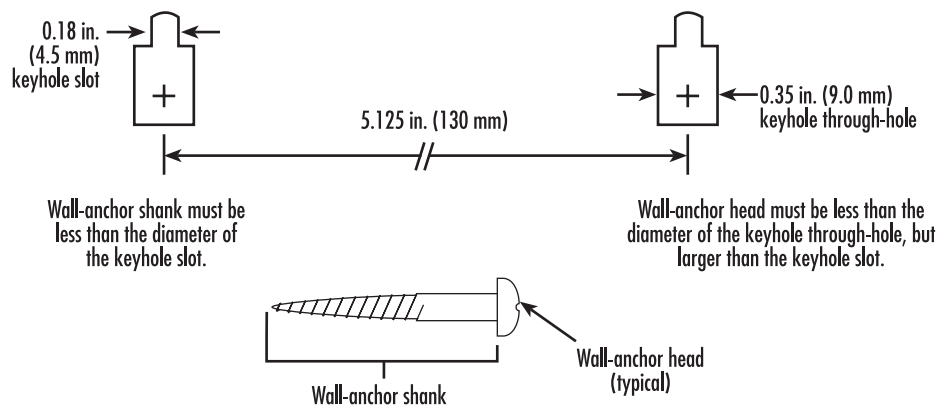

Figure 45. Wall-mounting hole dimensions

Note Mounting hardware is not provided. The installer must determine which fastener is appropriate for that particular application.

2. Install the (user-provided) wall anchors. Any standard anchoring method may be used, such as wood screws; butterfly anchors/molly bolts (for installation into a sheetrock/drywall or plasterboard surface); or expansion bolts (for installation into a concrete or masonry surface). The anchor screw heads must have just enough clearance to allow the wall-mounting key holes (see [figure 44](#) on page 77) to slip onto them when hanging the SmartNode 1400.
3. Hang the SmartNode 1400 on the wall-anchor mounting screws.

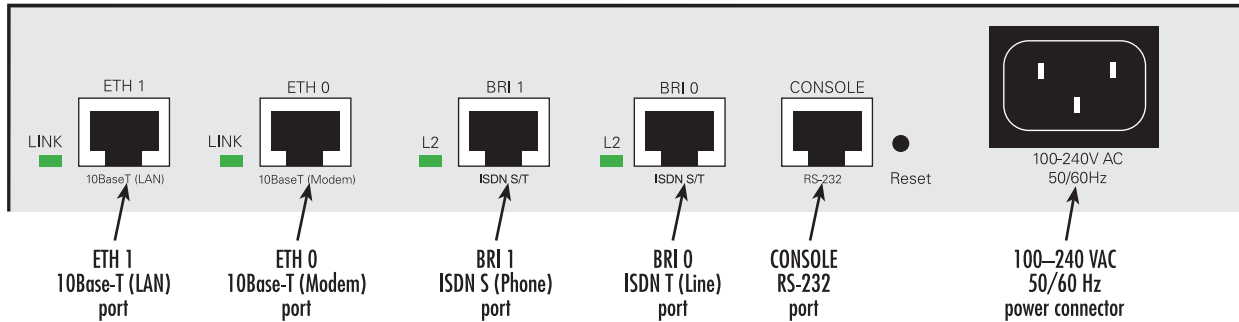

Figure 46. SmartNode 1400 connectors

Connecting cables

Installing SmartNode 1400 cables takes place in the following order:



Do not work on the system or connect or disconnect cables during periods of lightning activity.

1. Installing the 10Base-T Ethernet cable into ports *ETH 0* and *ETH 1* (see [figure 46](#)) (see “[Installing the Ethernet cables](#)” on page 79).
2. Installing the BRI 0 and BRI 1 cables (see “[Installing the BRI cables](#)” on page 80).
3. Installing the power cord (see “[Installing the power cord](#)” on page 84).

Installing the Ethernet cables

Ethernet devices (10Base-T) are connected to the SmartNode’s Ethernet ports (see [table 23](#) for port pin-out listing) via a cable terminated with RJ-45 plugs. Use a cross-over cable to connect to a host (see [figure 47](#) on page 80), or a straight-through cable to connect to a hub (see [figure 48](#) on page 80).

Table 23. Ethernet 10Base-T (RJ-45) port pin-outs

Pin	Signal
1	TX+
2	TX-
3	RX+
6	RX-

Note Pins not listed are not used.

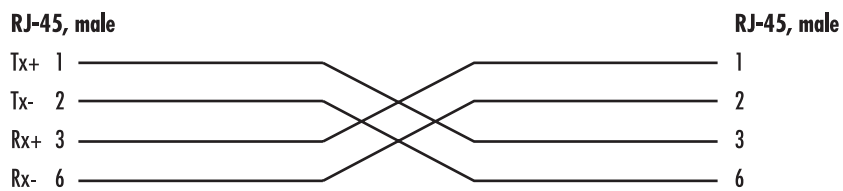
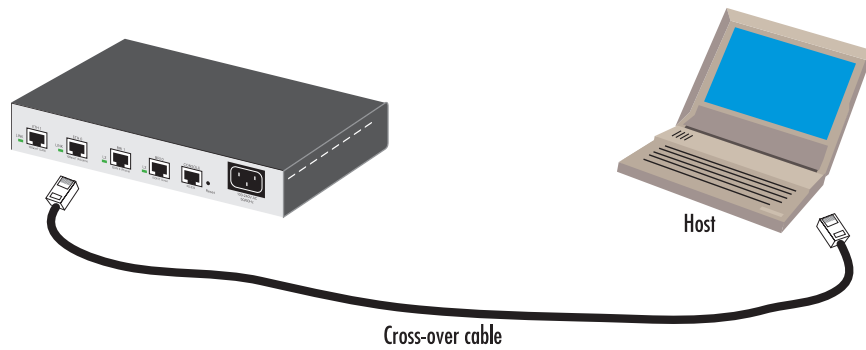

Figure 47. Connecting to a host

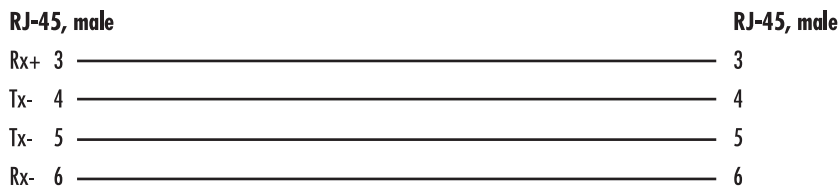
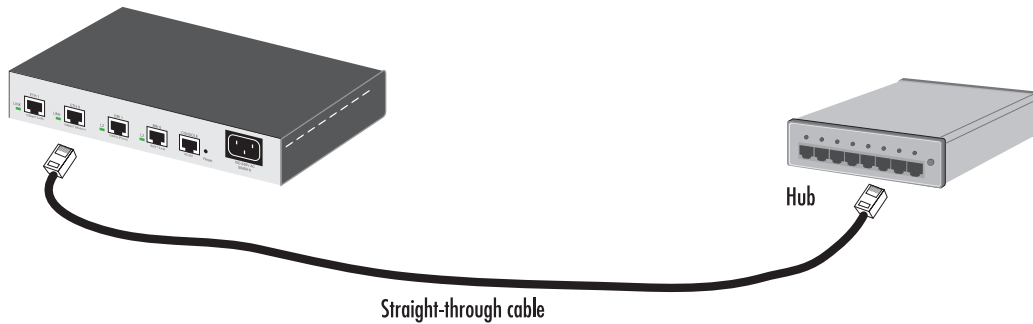

Figure 48. Connecting to a hub

Installing the BRI cables

A straight-through S-Bus cable terminated with RJ-45 plugs is used to connect an ISDN NT or TE to the SmartNode 1400 BRI ports (see [table 24](#) for port pin-out listing). If you are connecting a BRI to an ISDN

telephone, see [figure 49](#), or see [figure 50](#) on page 82 if you are connecting a BRI to an NT. For BRI ports with configurable pin outs ensure that the appropriate mode (NET or USR) is configured.

Table 24. BRI (RJ-45) port pin-outs

Pin	Signal (USR)	Signal (NET)
3	TX+	RX+
4	RX+	TX+
5	RX-	TX-
6	TX-	RX-

Note Pins not listed are not used.



Hazardous network voltages are present in the BRI cables. If you detach the cable, detach the end away from the SmartNode or interface card first to avoid possible electric shock. Network hazardous voltages may be present on the device in the area of the BRI port, regardless of when power is turned OFF.



To prevent damage to the system, make certain you connect the BRI cable to the BRI port only and not to any other RJ-45 socket.

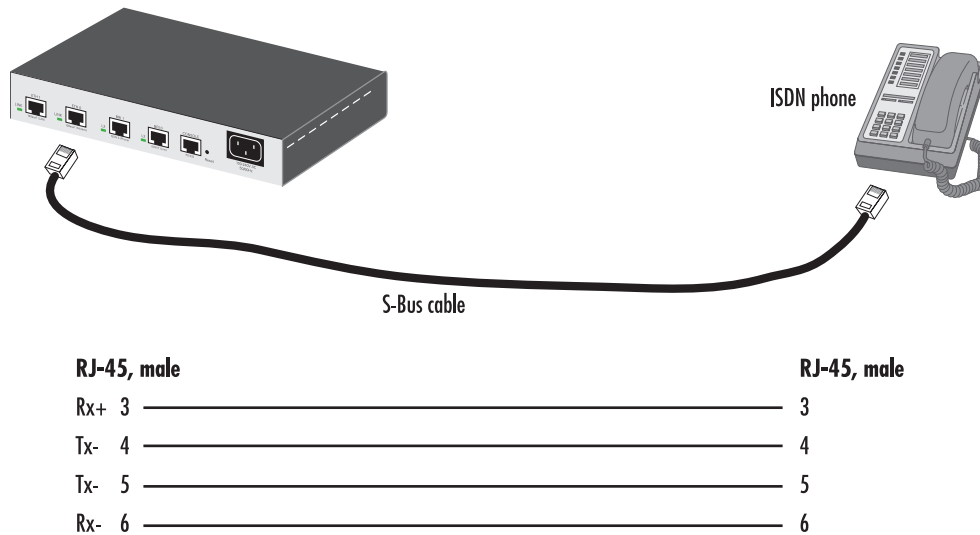

Figure 49. Connecting a BRI to an ISDN telephone

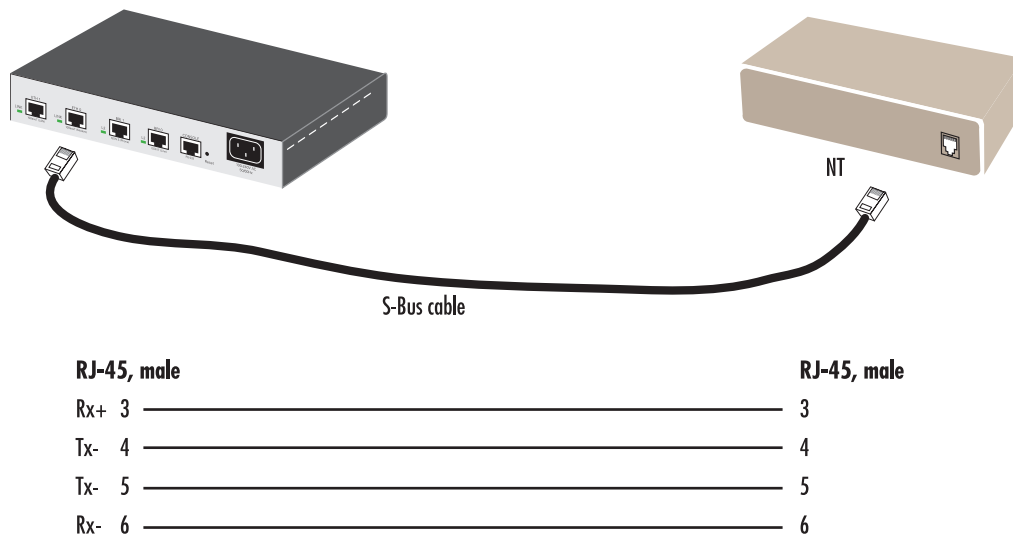

Figure 50. Connecting a BRI to an NT

External S-Bus power supply

Many ISDN telephone handsets require that 40-VDC power be supplied via the S-Bus connection. In other words, they have no separate or built-in power supply. In general, point-to-multipoint ISDN BRI NTs supply line power to the S-Bus. Point-to-point NTs connected to a PBX generally do not supply line power.

The SmartNode 1400 does not supply S-Bus line power on the BRI ports, however, there are two options to provide S-Bus line power:

- If one of the BRI ports is connected to an ISDN NT, the power supplied by the NT is fed through to the other BRI port.
- If line power is not available from the NT, but required for connected terminals, the PM-BRI-EXT S-Bus Phantom power supply can be used.

Table 25. PM-BRI-EXT S-Bus 40V power supply

Item	Phantom Power Supply; PM-BRI-EXT
Voltage Specifications	Input 230VAC, Output 40VDC



The PM-BRI-EXT power supply unit is equipped with a transformer that is specially designed for S-Bus line power. The use of a general purpose DC power transformer may cause equipment damage.



If you use a Phantom power supply other than that supplied by Patton Electronics Co., you must ensure that it conforms to ITU I.430 Section 9.7.3.2.2. which specifies that the maximum current delivered shall not exceed 200mA.

Note The PM-BRI-EXT is connected to the S-Bus via an S-Bus multi-socket.(see figure 51).



Do not plug the Phantom power supply directly into any other port than BRI 0. Installing it on the Ethernet ports or Console port could result in serious equipment damage.

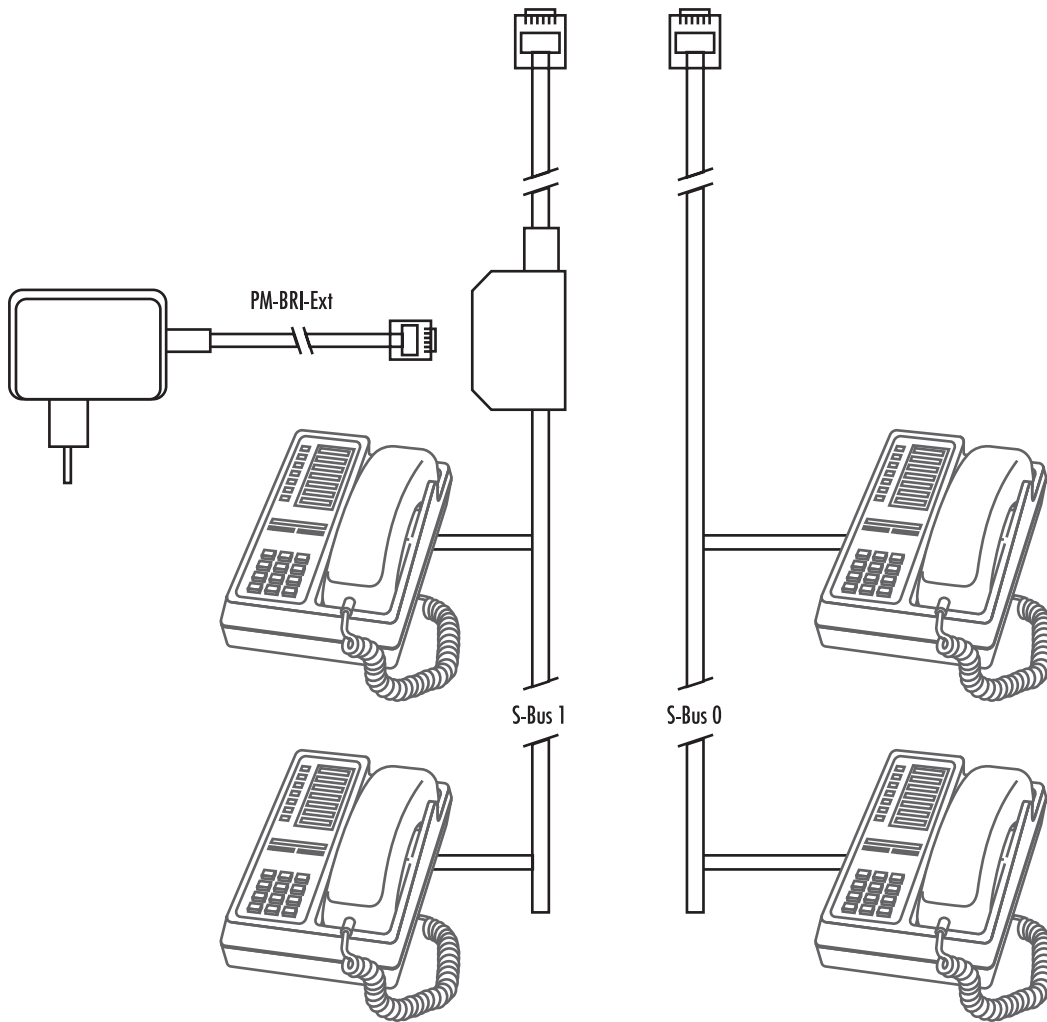
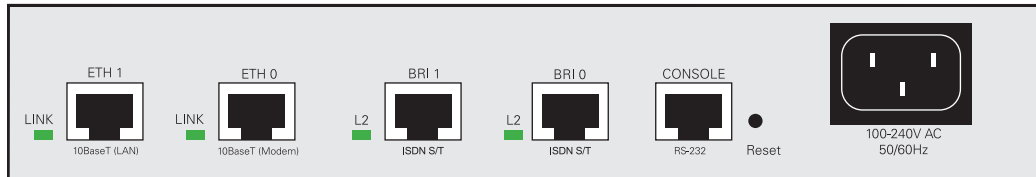

Figure 51. SmartNode 1400 external 40-VDC power supply

Installing the power cord

Do the following:

1. Insert the barrel type connector end of the AC power cord into the 100–240 VAC power connector (see [figure 46](#)).



The SmartNode 1400 power supply automatically adjusts to accept an input voltage from 100 to 240 VAC (50/60 Hz).

Verify that the proper voltage is present before plugging the power cord into the receptacle. Failure to do so could result in equipment damage.

Note *Do not connect the other end of the power cord to the power outlet at this time.*

2. Verify that the AC power cord included with your router is compatible with local standards. If it is not, refer to chapter 12, “[Contacting Patton for assistance](#)” on page 141 to find out how to replace it with a compatible power cord.
3. Connect the male end of the power cord to an appropriate power outlet.
4. Verify that the green *Power* LED is lit (see [figure 52](#)).
5. Unplug the power cord from the router to power down the unit.

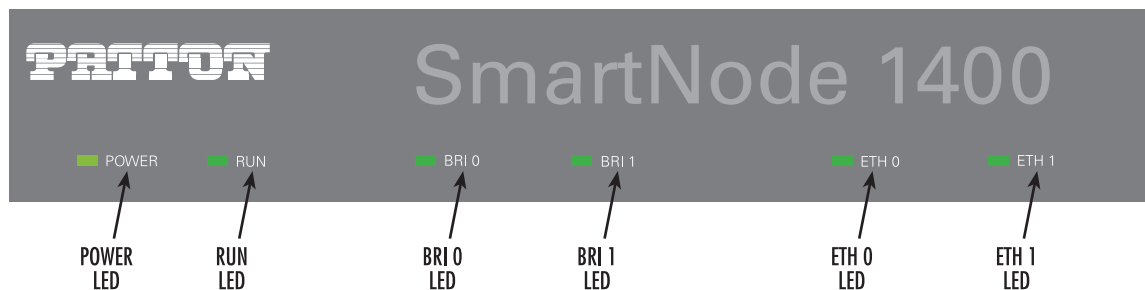

Figure 52. SmartNode 1400 front panel LEDs

Congratulations, you have finished installing the SmartNode 1400! Now go to chapter 10, “[Getting Started with the SmartNode Device](#)” on page 129.

Chapter 6 **SmartNode 2300 installation**

Chapter contents

Hardware installation	87
Mounting the SmartNode 2300	87
Desktop installation	88
Rack-mounted installation	88
Connecting cables.....	90
Installing the Ethernet cables	91
Installing the serial interface cable	92
Installing the interface card cables	94
Installing the IC-4FXS interface card cables	94
Installing the IC-4BRV interface card cables	95
Installing the IC-E1V interface card cables	97
Installing the IC-T1V interface card cables	98
Installing the power cord	99

Hardware installation

SmartNode 2300 installation consists of the following:

Note If you will be installing the 48V line power module prior to installing an interface card or ISDN S-Bus, refer to chapter 8, “[Line power module installation](#)” on page 115.

- Installing an interface card (if the card was not installed at the factory). Refer to chapter 9, “[Interface card installation](#)” on page 123 to install the card, then return to this chapter.
- Placing the device at the desired installation location (see section “[Mounting the SmartNode 2300](#)” on page 87)
- Installing the interface and power cables (see section “[Connecting cables](#)” on page 90)

When you finish installing the SmartNode 2300, go to chapter 10, “[Getting Started with the SmartNode Device](#)” on page 129.

Mounting the SmartNode 2300

The SmartNode 2300 should be placed in a dry environment with sufficient space to allow air circulation for cooling.

Note For proper ventilation, leave at least 2 inches (5 cm) to the left, right, front, and rear of the SmartNode 2300.

The SmartNode 2300 can be installed as follows:

- Placed on a desktop or similar sturdy, flat surface that offers easy access to the cables
- Mounted inside a 19-inch equipment rack

Note To prevent overheating we recommend that the SmartNode 2300 not be installed in a closed rack or in a room that is not properly ventilated or air-conditioned.

Desktop installation

Do the following to install the SmartNode 2300:

1. Remove one of the rubber pads from the adhesive strip (included in the SmartNode installation kit pack) and place it on a corner on the bottom of the SmartNode 2300 (see [figure 53](#)).

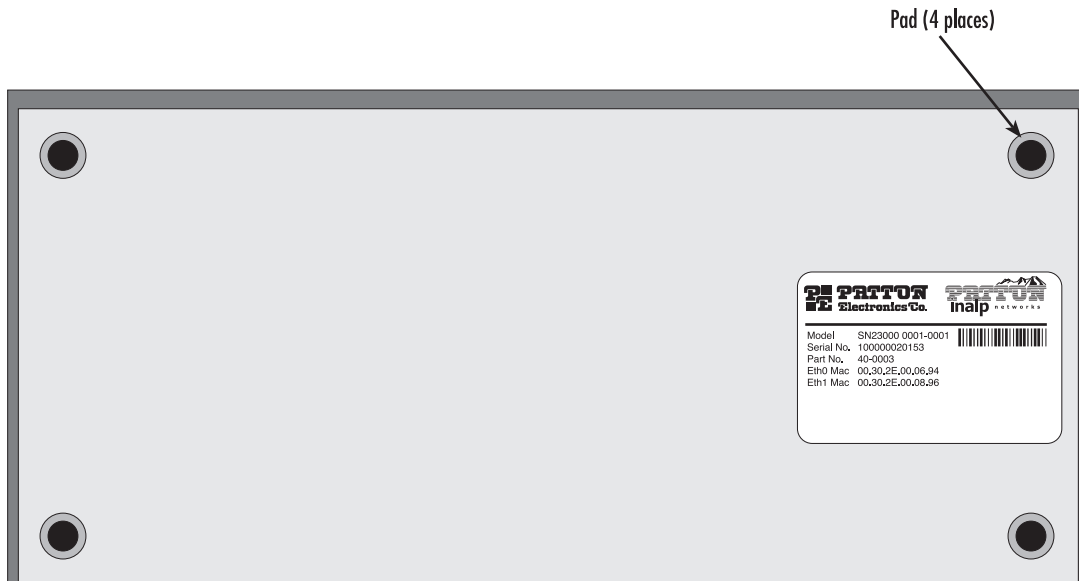

Figure 53. Pad locations

2. Repeat step 1 to install pads on the remaining three corners on the bottom of the SmartNode 2300.
3. Place the unit on a desktop, shelf or other flat, hard, and secure surface.

Note Allow sufficient space at the rear of the chassis for cable connections. In addition you should consider the need to access the chassis for future upgrades, maintenance and troubleshooting. Multiple SmartNodes can be stacked one atop the other.

Rack-mounted installation

For rack-mounting, screw holes are provided at standard mounting positions for industry-standard 19-inch equipment racks.

Note The SN2300 requires AC power 100–40V, 50/60Hz. Its power dissipation is 10W. It should be installed in an open rack wherever possible. If cabinet installation is unavoidable then ensure that the cabinet has adequate ventilation.

Install the rack-mount brackets before you install the SmartNode 2300 in the rack. When installing multiple SmartNode 2300s in one rack, we recommend that you leave one height unit (2.54 cm/1 inch) of clear space between two devices. Two rack mounting brackets and eight screws for attaching the brackets to the chassis are provided. The screws for installing the chassis in a rack are not included.

Do the following to mount a SmartNode 2300 in a 19-inch rack:

1. Locate the two angled mounting brackets included in the installation kit pack. The bracket (see [figure 54](#)) is designed so you can have the 1.5 cm flange facing to the front or to the rear. There are four holes for countersunk screws on the long side of the bracket.

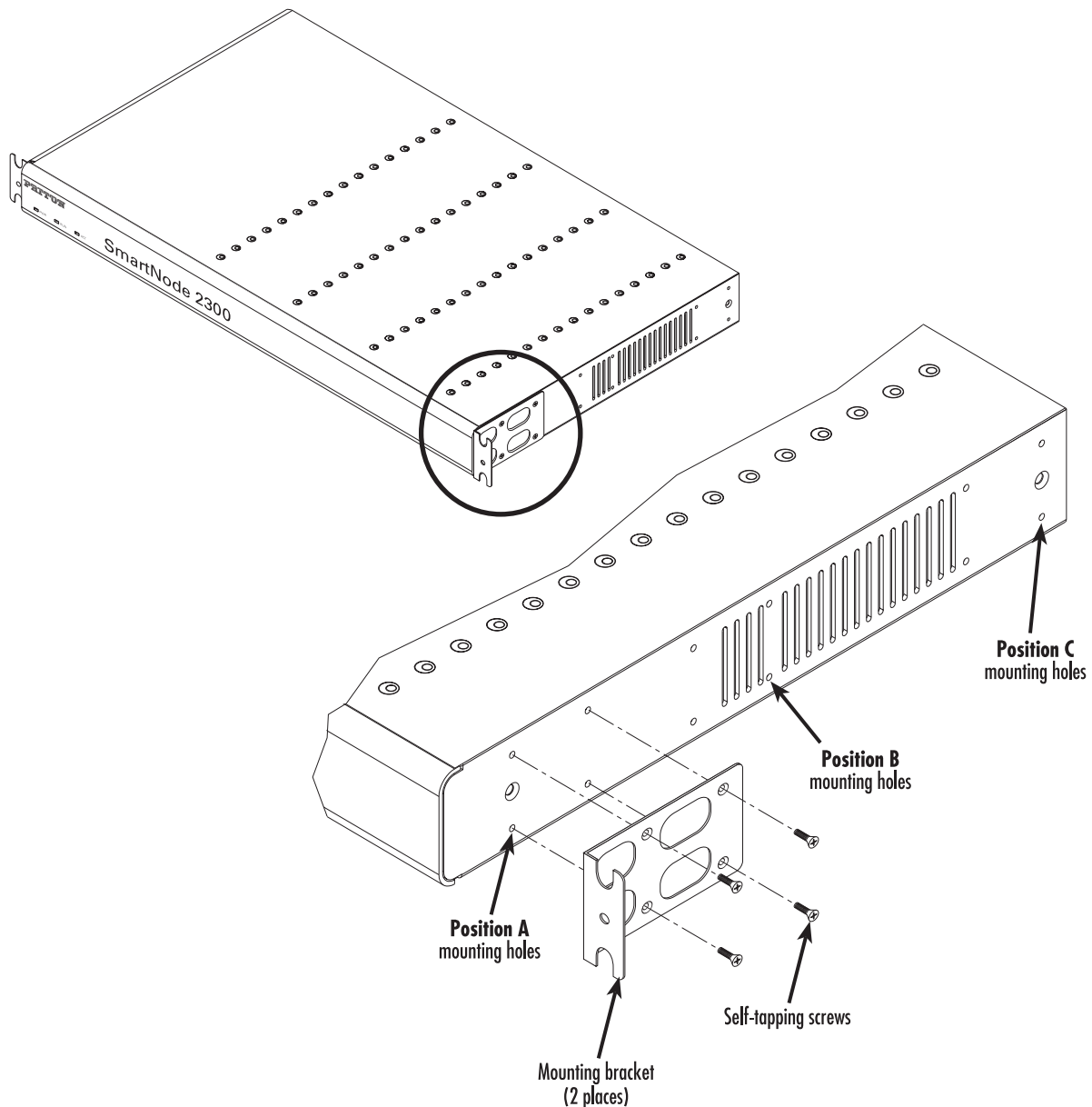

Figure 54. SmartNode 2300 rack mounting bracket location holes

2. Attach a bracket to each side of the SmartNode 2300 with the four self-tapping screws provided. There are three mounting positions for the brackets (positions A, B, and C as shown in [figure 54](#) on page 89), so choose the one that best suits your requirements.

3. Install the unit into the rack using the user-provided rack mounting hardware.

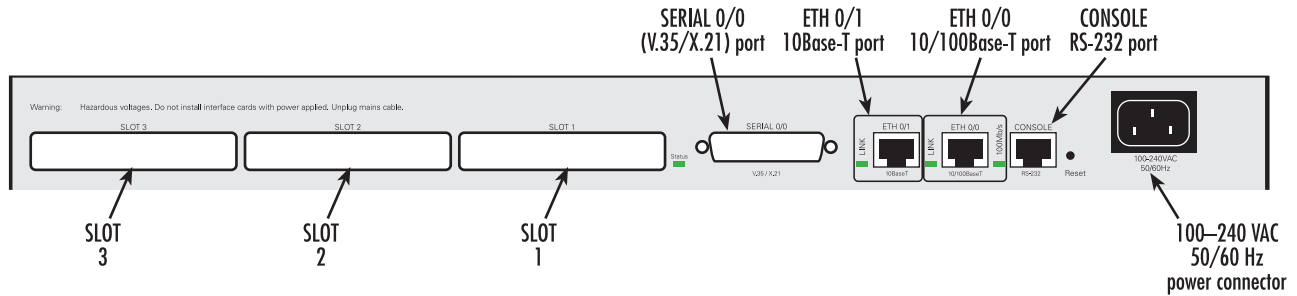

Figure 55. SmartNode 2300 connectors

Connecting cables

Installing SmartNode 2300 cables takes place in the following order:



Do not work on the system or connect or disconnect cables during periods of lightning activity.

1. Installing the 10Base-T Ethernet cable into port *ETH 0/1* or 10/100Base-T Ethernet cable into port *ETH 0/0* (see [figure 55](#)) (see “[Installing the Ethernet cables](#)” on page 91)
2. Installing the serial interface cable into port *SERIAL 0/0* (see “[Installing the serial interface cable](#)” on page 92)
3. Installing the interface card cables (see “[Installing the interface card cables](#)” on page 94)
4. Installing the power cord (see “[Installing the power cord](#)” on page 99)

Installing the Ethernet cables

Ethernet devices (10Base-T and 100Base-T) are connected to the SmartNode's Ethernet ports (see [table 26](#) for port pin-out listing) via a cable terminated with RJ-45 plugs. Use a cross-over cable to connect to a host (see [figure 56](#)), or a straight-through cable to connect to a hub (see [figure 57](#) on page 92).

Table 26. Ethernet 10Base-T (RJ-45) port pin-outs

Pin	Signal
1	TX+
2	TX-
3	RX+
6	RX-

Note Pins not listed are not used.

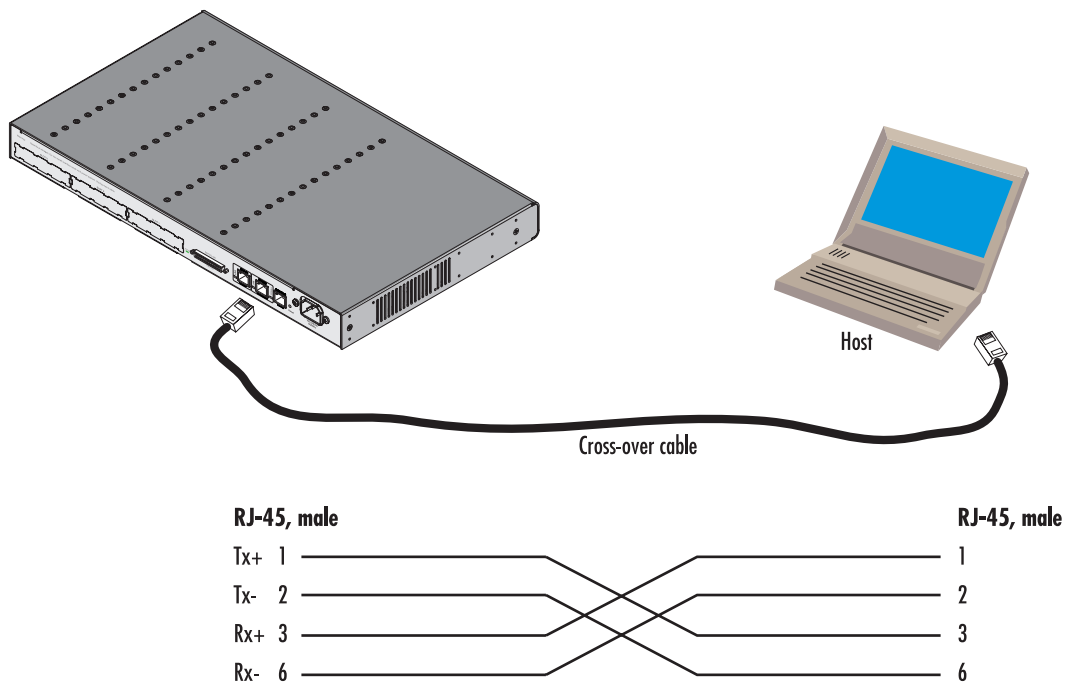

Figure 56. Connecting to a host

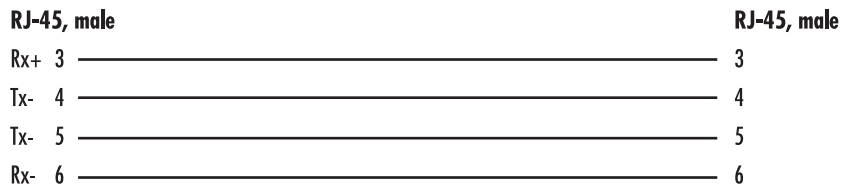
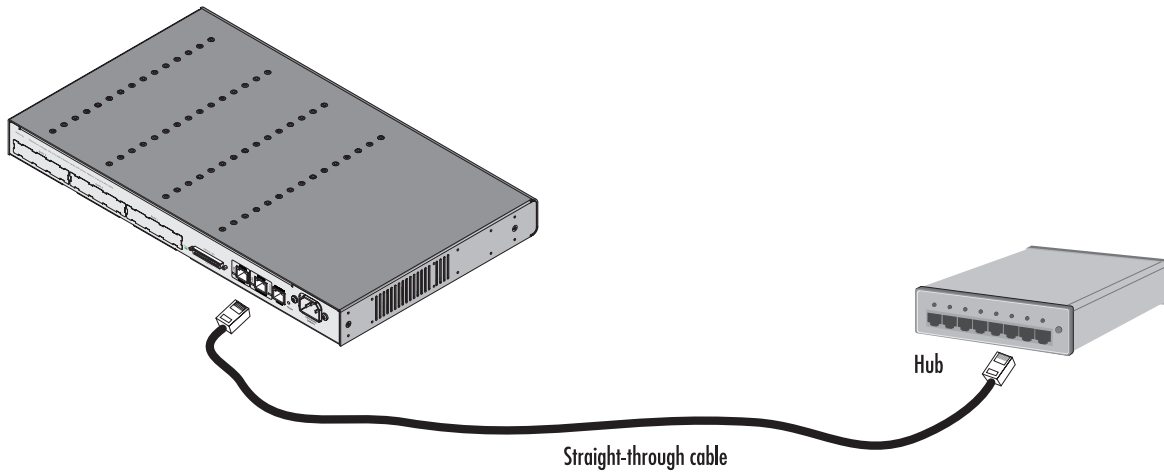

Figure 57. Connecting to a hub

Installing the serial interface cable

Serial devices (V.35 or X.21) are connected to the SmartNode’s serial ports (see [table 27](#) for port pin-out listing) via a cable terminated at the SmartNode 2300 with a DB-25 connector.

Table 27. Serial port V.35 and X.21 signals

Signal V.35		Signal X.21	
Pin	Description	Pin	Description
1	Frame Ground	7	Signal Ground
4	DCD	9	RXDa
6	DTR	10	RXD _b
7	Signal Ground	11	TXD _b
8	RTS	12	TXDa
9	RXD _a	13	CNT _b
10	RXD _b	14	CNT _a
11	TXD _b	16	IND _b
12	TXDa	21	SET _b
16	TXCb	22	SET _a
21	RXC _b	23	IND _a
22	RXC _a		
23	TXCa		
25	CTS		

Note Some NTUs have non-standard or mirrored connections and require special cables. Consult the NTU maker's product documentation.

Installing the interface card cables

The following interface cards are available for use with the SmartNode 2300:

- **IC-4FXS**—Gateway interface card for 4 analog FXS ports (see section “[Installing the IC-4FXS interface card cables](#)”)
- **IC-4BRV**—8-channel gateway interface card for ISDN BRI (see section “[Installing the IC-4BRV interface card cables](#)” on page 95)
- **IC-E1V**—30-channel E1 gateway interface card for ISDN PRI (see section “[Installing the IC-E1V interface card cables](#)” on page 97)
- **IC-T1V**—23-channel T1 gateway interface card for ISDN PRI (see section “[Installing the IC-T1V interface card cables](#)” on page 98)

Determine which cards are installed in your SmartNode 2300, then go to the appropriate section to install the device.

Installing the IC-4FXS interface card cables

The IC-4FXS supports up to four analog connections (see [table 27](#) for port pin-out listing) via cables terminated with RJ-12 plugs (see [figure 59](#) on page 95).

Table 28. RJ-12 socket

Pin	Signal
3	Ring (-)
4	Tip (+)

Note The IC-4FXS is actually equipped with RJ-11 sockets. An RJ-11 socket is similar to an RJ-12 socket but pins 1 and 6 are omitted.

Note Pins not listed are not used.

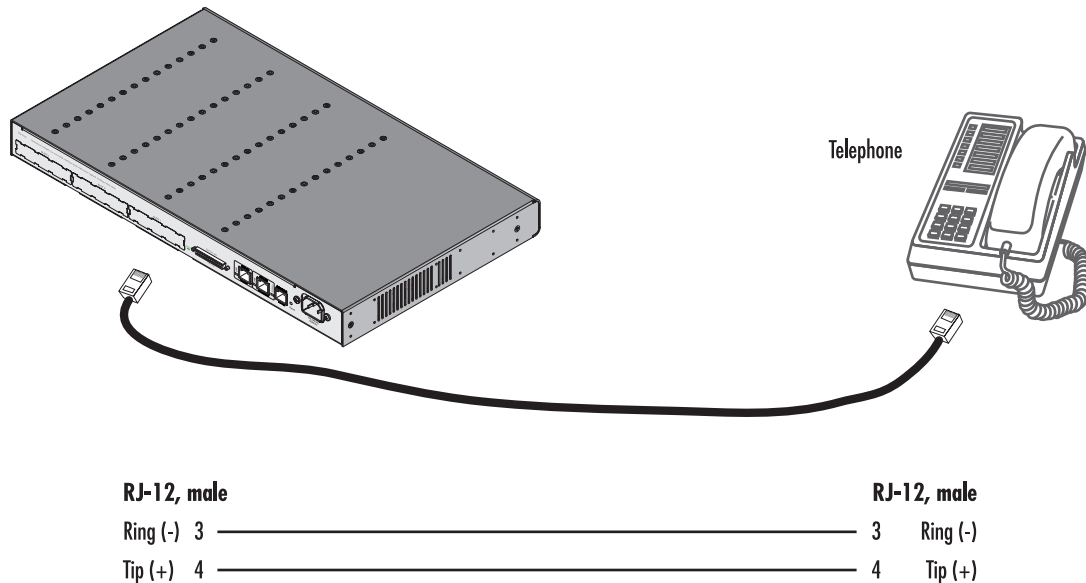

Figure 59. Analog FXS connection

Installing the IC-4BRV interface card cables

A straight-through S-Bus cable terminated with RJ-45 plugs is used to connect an ISDN NT or TE to the interface card ports (see [table 29](#) for port pin-out listing). If you are connecting a BRI to an ISDN telephone, see [figure 60](#); or see [figure 61](#) on page 96 if you are connecting a BRI to an NT. For BRI ports with configurable pin-outs ensure that the appropriate mode (NET or USR) is configured.

Table 29. BRI (RJ-45) port pin-outs

Pin	Signal (USR)	Signal (NET)
3	TX+	RX+
4	RX+	TX+
5	RX-	TX-
6	TX-	RX-

Note Pins not listed are not used.



Hazardous network voltages are present in the BRI cables. If you detach the cable, detach the end away from the SmartNode or interface card first to avoid possible electric shock. Network hazardous voltages may be present on the device in the area of the BRI port, regardless of when power is turned OFF.



To prevent damage to the system, make certain you connect the BRI cable to the BRI port only and not to any other RJ-45 socket.

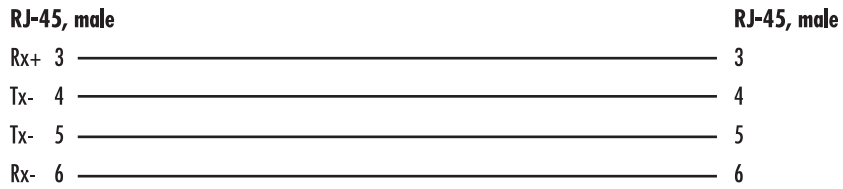

Figure 60. Connecting a BRI to an ISDN telephone

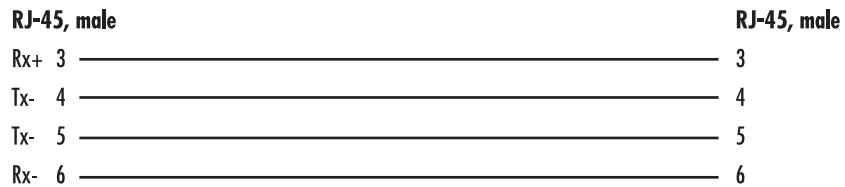
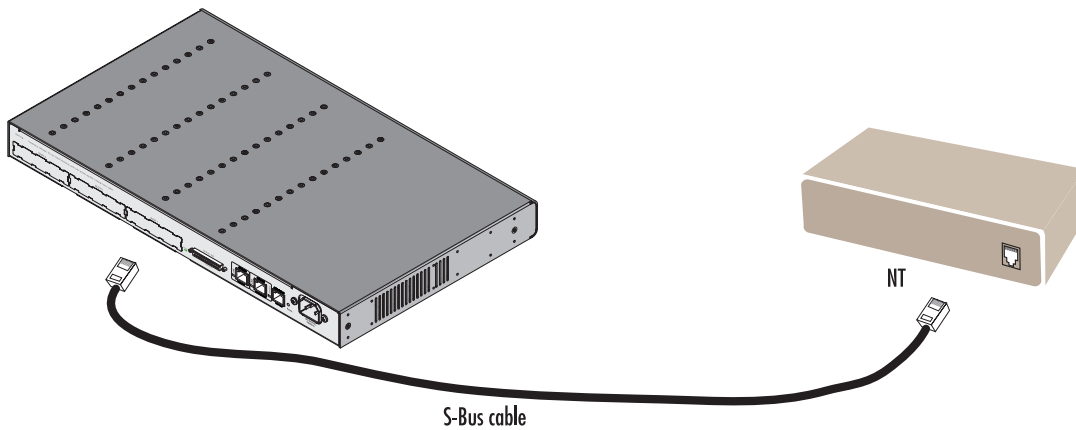

Figure 61. Connecting a BRI to an NT

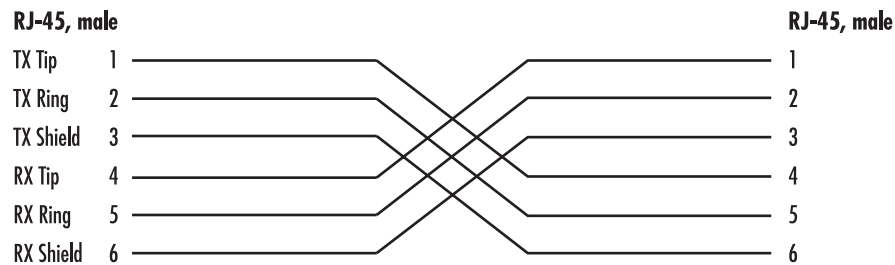
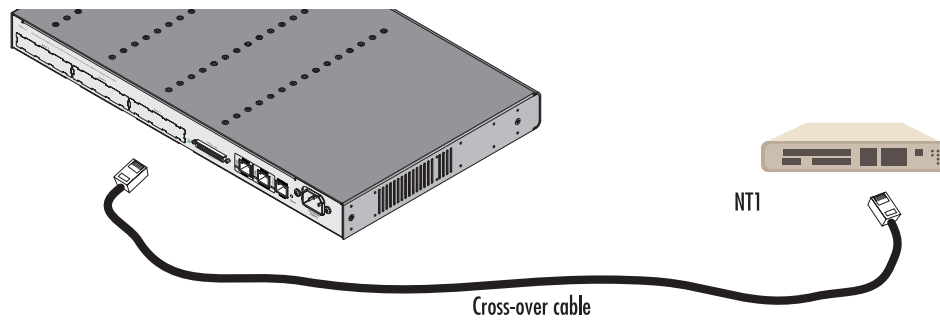

Figure 62. Connecting a PRI port to an NT1

Installing the IC-E1V interface card cables

The PRI is usually connected to a PBX or switch (local exchange (LE)). Type and pin-outs of these devices vary depending on the manufacturer. In most cases, a straight-through RJ-45 to RJ-45 can be used to connect the PRI (see [table 30](#) for IC-E1V card port pin-out listing) with a PBX. A cross-over cable is required to connect to an NT1, as illustrated in [figure 62](#).

Table 30. RJ-45 socket

Pin	USR
1	TX Tip
2	TX Ring
3	TX Shield
4	RX Tip
5	RX Ring
6	RX Shield

Note Pins not listed are not used.



Hazardous network voltages are present in the PRI cables. If you detach the cable, detach the end away from the SmartNode or interface card first to avoid possible electric shock. Network hazardous voltages may be present on the device in the area of the PRI port, regardless of when power is turned OFF.



To prevent damage to the system, make certain you connect the PRI cable to the PRI port only and not to any other RJ-45 socket.

Installing the IC-T1V interface card cables

The PRI is usually connected to a PBX or switch—local exchange (LE). Type and pin outs of these devices vary depending on the manufacturer. In most cases, a straight-through RJ-45 to RJ-45 can be used to connect the PRI (see [table 31](#) for IC-T1V card port pin-out listing) with a PBX. A cross-over cable is required to connect to an NT2, as illustrated in [figure 63](#).

Table 31. RJ-45 socket

Pin	USR
1	TX Tip
2	TX Ring
3	TX Shield
4	RX Tip
5	RX Ring
6	RX Shield

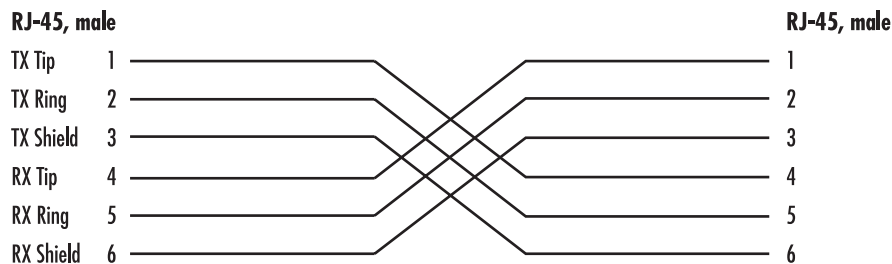
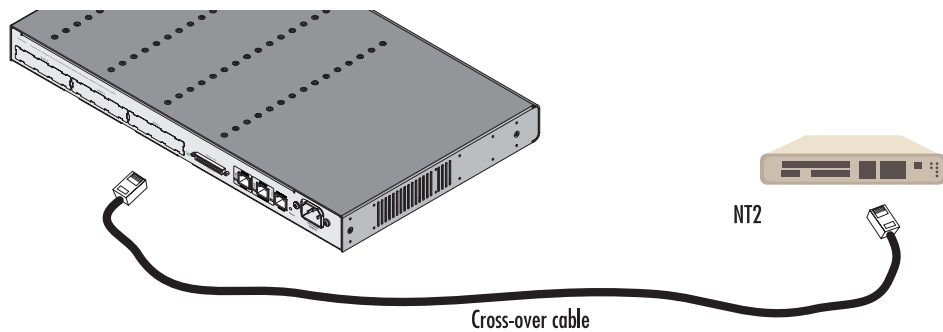

Figure 63. Connecting a PRI port to an NT2

Note Pins not listed are not used.



Hazardous network voltages are present in the PRI cables. If you detach the cable, detach the end away from the SmartNode or interface card first to avoid possible electric shock. Network hazardous voltages may be present on the device in the area of the PRI port, regardless of when power is turned OFF.



To prevent damage to the system, make certain you connect the PRI cable to the PRI port only and not to any other RJ-45 socket.

Installing the power cord

Do the following:

1. Insert the barrel type connector end of the AC power cord into the 100–240 VAC power connector (see [figure 55](#)).



The SmartNode 2300 power supply automatically adjusts to accept an input voltage from 100 to 240 VAC (50/60 Hz).

Verify that the proper voltage is present before plugging the power cord into the receptacle. Failure to do so could result in equipment damage.

Note *Do not connect the other end of the power cord to the power outlet at this time.*

2. Verify that the AC power cord included with your router is compatible with local standards. If it is not, refer to chapter 12, “[Contacting Patton for assistance](#)” on page 141 to find out how to replace it with a compatible power cord.
3. Connect the male end of the power cord to an appropriate power outlet.
4. Verify that the green *PWR* LED is lit (see [figure 64](#)).
5. Unplug the power cord from the router to power down the unit.



Figure 64. SmartNode 2300 front panel LEDs

Congratulations, you have finished installing the SmartNode 2300! Now go to chapter 10, “[Getting Started with the SmartNode Device](#)” on page 129.

Chapter 7 **SmartNode 2400 installation**

Chapter contents

Hardware installation	103
Mounting the SmartNode 2400	103
Desktop installation	104
Rack-mounted installation	104
Connecting cables.....	106
Installing the Ethernet cables	107
Installing the interface card cables	108
Installing the IC-4FXS interface card cables	109
Installing the IC-4BRV interface card cables	110
Installing the IC-E1V interface card cables	111
Installing the IC-T1V interface card cables	113
Installing the power cord	114

Hardware installation

SmartNode 2400 installation consists of the following:

Note If you will be installing the 40V line power module prior to installing an interface card or ISDN S-Bus, refer to chapter 8, “[Line power module installation](#)” on page 115.

- Installing an interface card (if the card was not installed at the factory). Refer to chapter 9, “[Interface card installation](#)” on page 123 to install the card, then return to this chapter.
- Placing the device at the desired installation location (see section “[Mounting the SmartNode 2400](#)” on page 103)
- Installing the interface and power cables (see section “[Connecting cables](#)” on page 106)

When you finish installing the SmartNode 2400, go to chapter 10, “[Getting Started with the SmartNode Device](#)” on page 129.

Mounting the SmartNode 2400

The SmartNode 2400 should be placed in a dry environment with sufficient space to allow air circulation for cooling.

Note For proper ventilation, leave at least 2 inches (5 cm) to the left, right, front, and rear of the SmartNode 2400.

The SmartNode 2400 can be installed as follows:

- Placed on a desktop or similar sturdy, flat surface that offers easy access to the cables
- Mounted inside a 19-inch equipment rack

Note To prevent overheating we recommend that the SmartNode 2400 not be installed in a closed rack or in a room that is not properly ventilated or air-conditioned.

Desktop installation

Do the following to install the SmartNode 2400:

1. Remove one of the rubber pads from the adhesive strip (included in the SmartNode installation kit pack) and place it on a corner on the bottom of the SmartNode 2400 (see [figure 65](#)).



Figure 65. Pad locations

2. Repeat step 1 to install pads on the remaining three corners on the bottom of the SmartNode 2400.
3. Place the unit on a desktop, shelf or other flat, hard, and secure surface.

Note Allow sufficient space at the rear of the chassis for cable connections. In addition you should consider the need to access the chassis for future upgrades, maintenance and troubleshooting. Multiple SmartNodes can be stacked one atop the other.

Rack-mounted installation

For rack-mounting, screw holes are provided at standard mounting positions for industry-standard 19-inch equipment racks.

Note The SmartNode 2400 requires AC power 100–40V, 50/60Hz. Its power dissipation is 10W. It should be installed in an open rack whenever possible. If cabinet installation is unavoidable then ensure that the cabinet has adequate ventilation.

Install the rack-mount brackets before you install the SmartNode 2400 in the rack. When installing multiple SmartNode 2400s in one rack, we recommend that you leave one height unit (2.54 cm/1 inch) of clear space between two devices. Two rack mounting brackets and eight screws for attaching the brackets to the chassis are provided. The screws for installing the chassis in a rack are not included.

Do the following to mount a SmartNode 2400 in a 19-inch rack:

1. Locate the two angled mounting brackets included in the installation kit pack. The bracket (see [figure 66](#)) is designed so you can have the 1.5 cm flange facing to the front or to the rear. There are four holes for countersunk screws on the long side of the bracket.

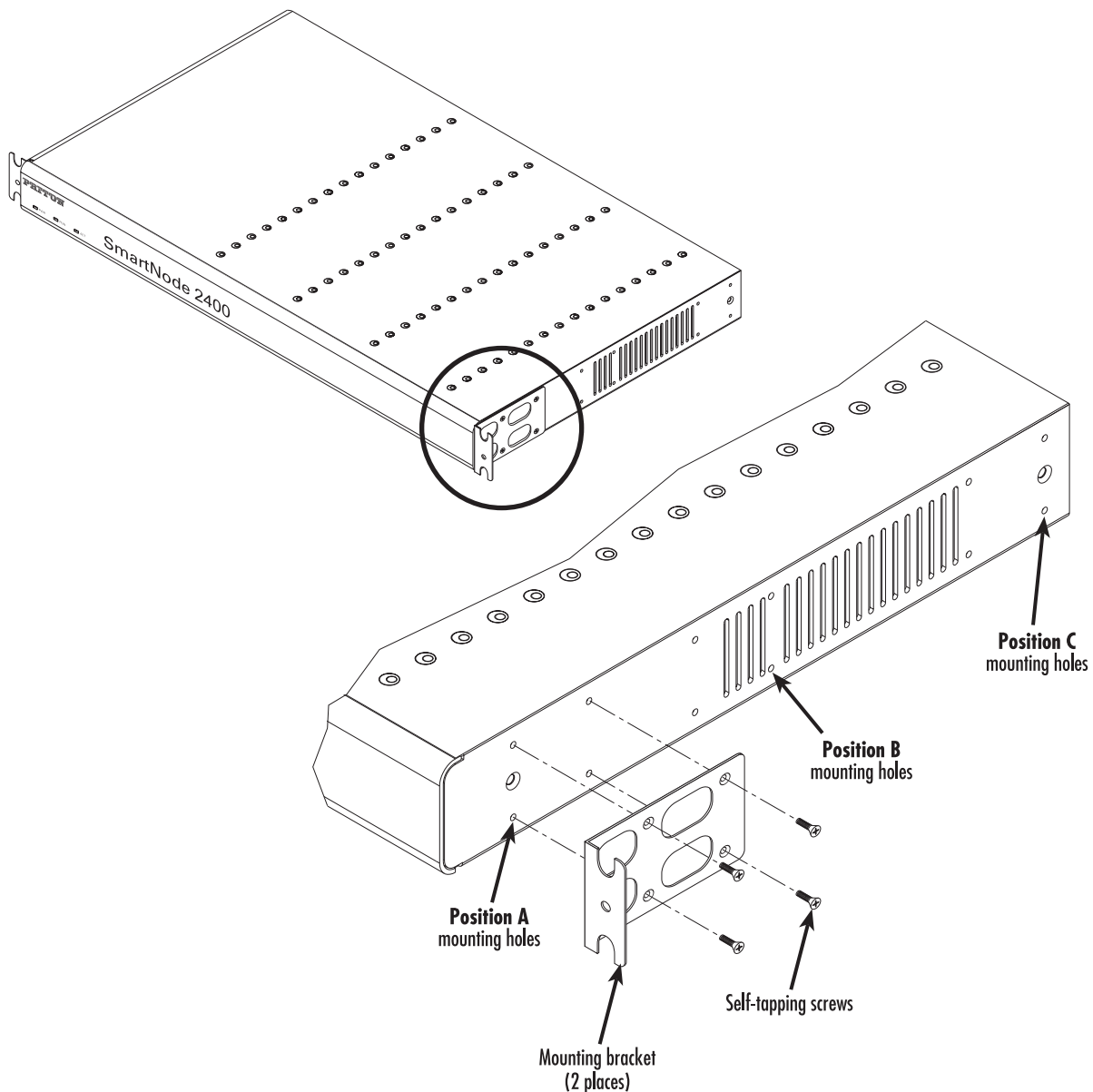

Figure 66. SmartNode 2400 rack mounting bracket location holes

2. Attach a bracket to each side of the SmartNode 2400 with the four self-tapping screws provided. There are three mounting positions for the brackets (positions A, B, and C as shown in [figure 66](#) on page 105), so choose the one that best suits your requirements.
3. Install the unit into the rack using the user-provided rack mounting hardware.

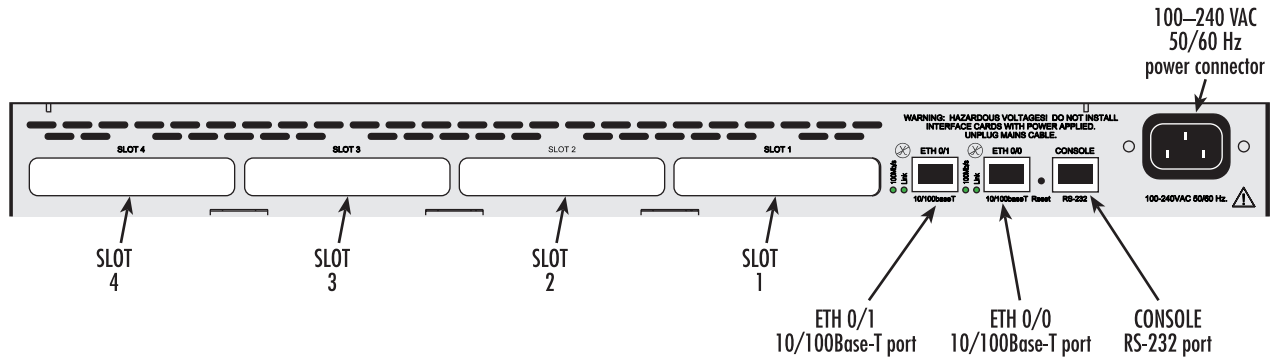

Figure 67. SmartNode 2400 connectors

Connecting cables

Installing SmartNode 2400 cables takes place in the following order:



Do not work on the system or connect or disconnect cables during periods of lightning activity.

1. Installing the 10Base-T or 100Base-T Ethernet cables into ports *ETH 0/1* and *ETH 0/0* (see [figure 67](#)) (see “[Installing the Ethernet cables](#)” on page 107).
2. Installing the interface card cables (see “[Installing the interface card cables](#)” on page 108).
3. Installing the power cord (see “[Installing the power cord](#)” on page 114).

Installing the Ethernet cables

Ethernet devices (10Base-T and 100Base-T) are connected to the SmartNode's Ethernet ports (see [table 32](#) for port pin-out listing) via a cable terminated with RJ-45 plugs. Use a cross-over cable to connect to a host (see [figure 68](#)), or a straight-through cable to connect to a hub (see [figure 69](#) on page 108).

Table 32. Ethernet 10Base-T (RJ-45) port pin-outs

Pin	Signal
1	TX+
2	TX-
3	RX+
6	RX-

Note Pins not listed are not used.

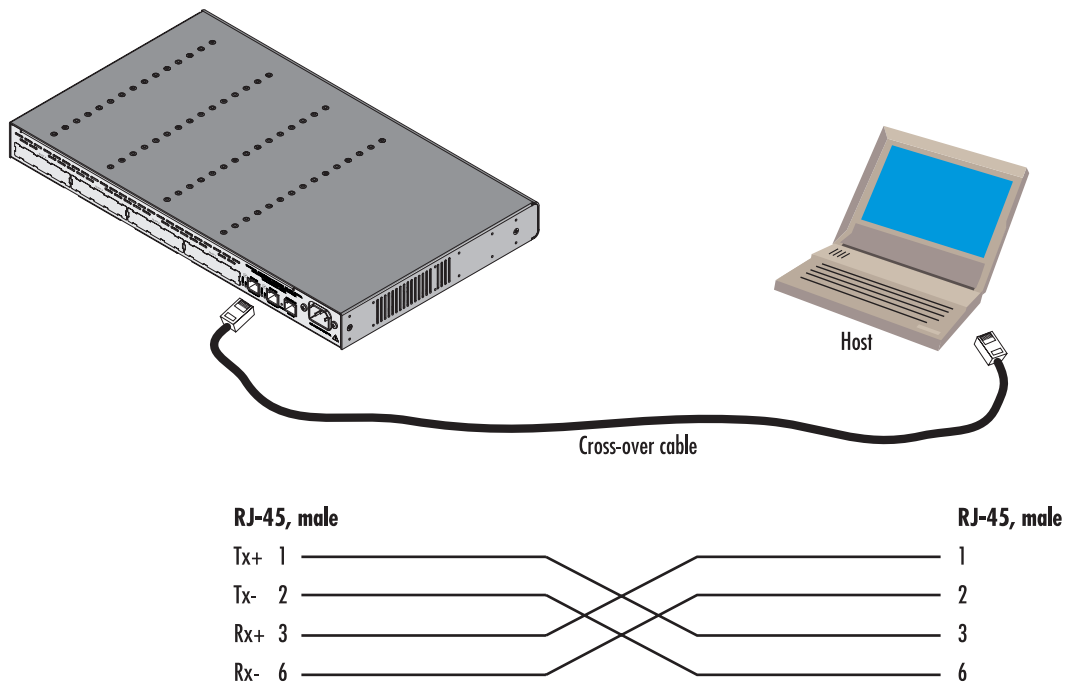

Figure 68. Connecting to a host

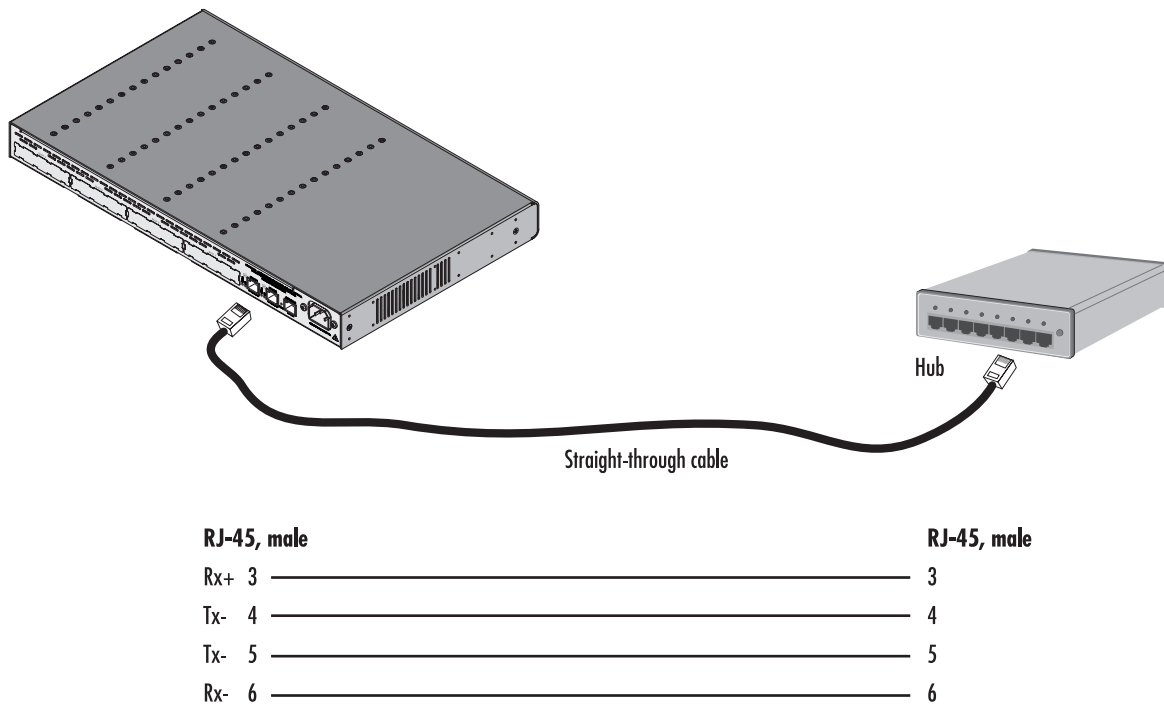

Figure 69. Connecting to a hub

Installing the interface card cables

The following interface cards are available for use with the SmartNode 2400:

- **IC-4FXS**—Gateway interface card for 4 analog FXS ports (see section “Installing the IC-4FXS interface card cables”)
- **IC-4BRV**—8-channel gateway interface card for ISDN BRI (see section “Installing the IC-4BRV interface card cables” on page 110)
- **IC-E1V**—30-channel E1 gateway interface card for ISDN PRI (see section “Installing the IC-E1V interface card cables” on page 111)
- **IC-T1V**—23-channel T1 gateway interface card for ISDN PRI (see section “Installing the IC-T1V interface card cables” on page 113)

Determine which cards are installed in your SmartNode 2400, then go to the appropriate section to install the device.

Installing the IC-4FXS interface card cables

The IC-4FXS supports up to four analog connections (see [table 33](#) for port pin-out listing) via cables terminated with RJ-12 plugs (see [figure 70](#) on page 109).

Table 33. RJ-12 socket

Pin	Signal
3	Ring (-)
4	Tip (+)

Note The IC-4FXS is actually equipped with RJ-11 sockets. An RJ-11 socket is similar to an RJ-12 socket but pins 1 and 6 are omitted.

Note Pins not listed are not used.

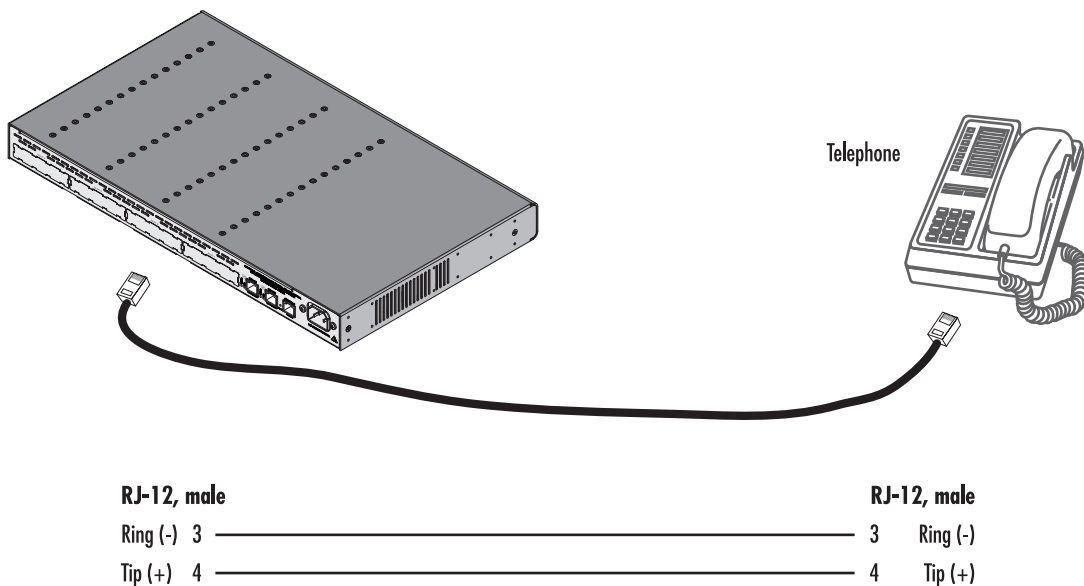

Figure 70. Analog FXS connection

Installing the IC-4BRV interface card cables

A straight-through S-Bus cable terminated with RJ-45 plugs is used to connect an ISDN NT or TE to the interface card ports (see [table 34](#) for port pin-out listing). If you are connecting a BRI to an ISDN telephone, see [figure 71](#); or see [figure 72](#) on page 111 if you are connecting a BRI to an NT. For BRI ports with configurable pin-outs ensure that the appropriate mode (NET or USR) is configured.

Table 34. BRI (RJ-45) port pin-outs

Pin	Signal (USR)	Signal (NET)
3	TX+	RX+
4	RX+	TX+
5	RX-	TX-
6	TX-	RX-

Note Pins not listed are not used.



Hazardous network voltages are present in the BRI cables. If you detach the cable, detach the end away from the SmartNode or interface card first to avoid possible electric shock. Network hazardous voltages may be present on the device in the area of the BRI port, regardless of when power is turned OFF.



To prevent damage to the system, make certain you connect the BRI cable to the BRI port only and not to any other RJ-45 socket.

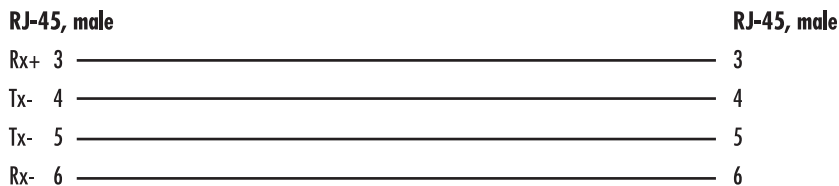
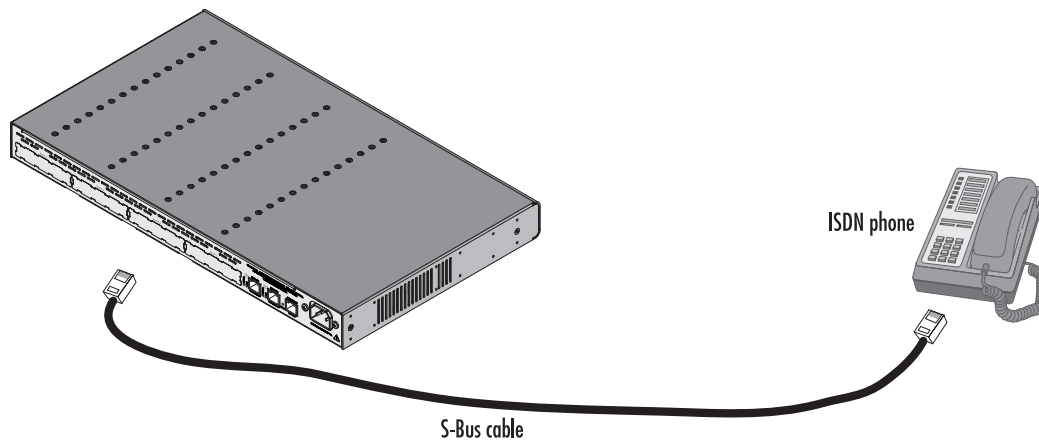

Figure 71. Connecting a BRI to an ISDN telephone

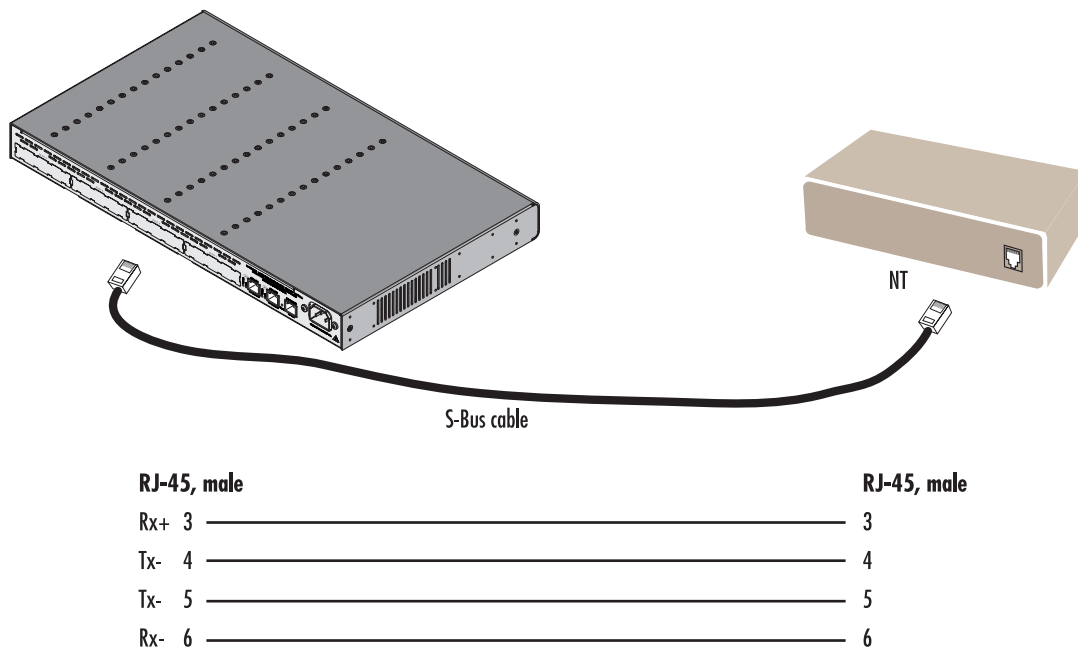

Figure 72. Connecting a BRI to an NT

Installing the IC-E1V interface card cables

The PRI is usually connected to a PBX or switch (local exchange (LE)). Type and pin-outs of these devices vary depending on the manufacturer. In most cases, a straight-through RJ-45 to RJ-45 can be used to connect the PRI (see [table 35](#) for IC-E1V card port pin-out listing) with a PBX. A cross-over cable is required to connect to a NT1, as illustrated in [figure 73](#) on page 112.

Table 35. RJ-45 socket

Pin	USR
1	TX Tip
2	TX Ring
3	TX Shield
4	RX Tip
5	RX Ring
6	RX Shield

Note Pins not listed are not used.



Hazardous network voltages are present in the PRI cables. If you detach the cable, detach the end away from the SmartNode or interface card first to avoid possible electric shock. Network hazardous voltages may be present on the device in the area of the PRI port, regardless of when power is turned OFF.



To prevent damage to the system, make certain you connect the PRI cable to the PRI port only and not to any other RJ-45 socket.

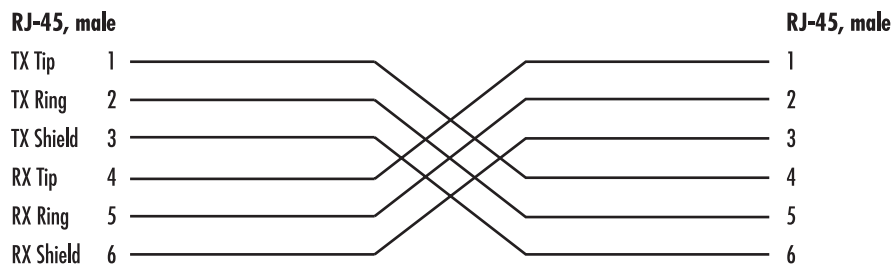
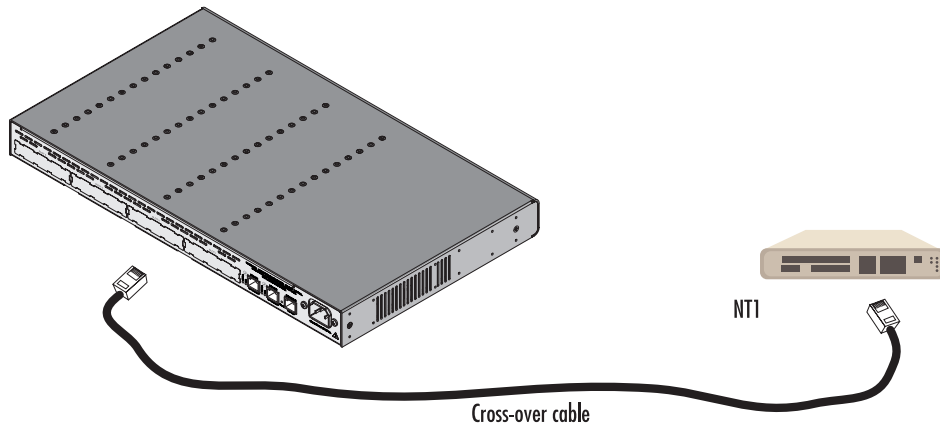

Figure 73. Connecting a PRI port to an NT1

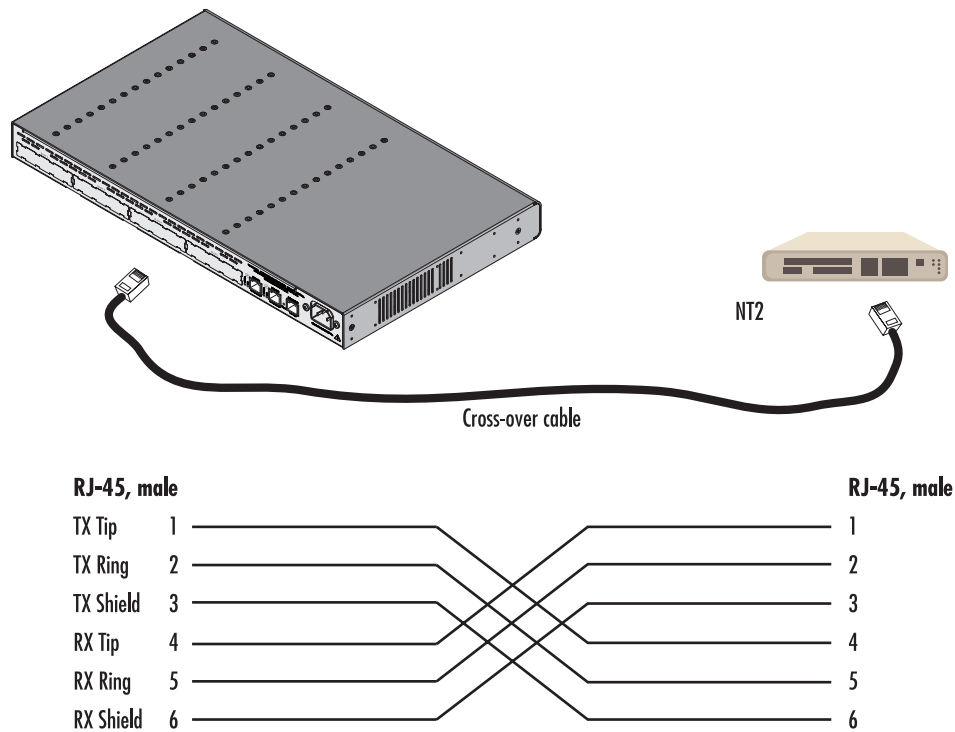

Figure 74. Connecting a PRI port to an NT2

Installing the IC-T1V interface card cables

The PRI is usually connected to a PBX or switch—local exchange (LE). Type and pin outs of these devices vary depending on the manufacturer. In most cases, a straight-through RJ-45 to RJ-45 can be used to connect the PRI (see [table 36](#) for IC-T1V card port pin-out listing) with a PBX. A cross-over cable is required to connect to a NT2, as illustrated in [figure 74](#).

Table 36. RJ-45 socket

Pin	USR
1	TX Tip
2	TX Ring
3	TX Shield
4	RX Tip
5	RX Ring
6	RX Shield

Note Pins not listed are not used.



Hazardous network voltages are present in the PRI cables. If you detach the cable, detach the end away from the SmartNode or interface card first to avoid possible electric shock. Network hazardous voltages may be present on the device in the area of the PRI port, regardless of when power is turned OFF.



To prevent damage to the system, make certain you connect the PRI cable to the PRI port only and not to any other RJ-45 socket.

Installing the power cord

Do the following:

1. Insert the barrel type connector end of the AC power cord into the 100–240 VAC power connector (see [figure 67](#)).



The SmartNode 2400 power supply automatically adjusts to accept an input voltage from 100 to 240 VAC (50/60 Hz).

Verify that the proper voltage is present before plugging the power cord into the receptacle. Failure to do so could result in equipment damage.

Note *Do not connect the other end of the power cord to the power outlet at this time.*

2. Verify that the AC power cord included with your router is compatible with local standards. If it is not, refer to chapter 12, “[Contacting Patton for assistance](#)” on page 141 to find out how to replace it with a compatible power cord.
3. Connect the male end of the power cord to an appropriate power outlet.
4. Verify that the green *PWR* LED is lit (see [figure 75](#)).
5. Unplug the power cord from the router to power down the unit.



Figure 75. SmartNode 2400 front panel LEDs

Congratulations, you have finished installing the SmartNode 2400! Now go to chapter 10, “[Getting Started with the SmartNode Device](#)” on page 129.

Chapter 8 **Line power module installation**

Chapter contents

Introduction	117
Safety Recommendation	117
Internal PM-48V-INT or PM-40V-INT line power module installation.....	117
SmartNode 2300 line power module installation	118
SmartNode 2400 line power module installation	120
Completing the installation	121
External S-Bus power supply	122

Introduction

This chapter tells you how to install an optional internal 48V (or 40V) line power module in a SmartNode 2000 series device. It also describes the installation of the optional external S-Bus 40V power supply units.

Safety Recommendation

Follow these guidelines to ensure general safety:

- Keep the chassis area clear and dust-free during and after installation.
- Put the removed chassis cover in a safe place.
- Keep tools away from walk areas where you or others could fall over them.
- Do not wear loose clothing that could get caught in the electronic device or chassis.
- Do not perform any action that creates a potential hazard to people or that makes equipment unsafe.
- Before opening the chassis, disconnect all cables to avoid contact with hazardous voltages.



Mains Voltage: Do not open the case when the power cord is connected. Hazardous voltages exist in mains-connected cables. Do not touch power supply when the power cord is connected. Line voltages are present within the power supply when the power cord is connected.



Hazardous network voltages are present in WAN and telephone networks ports regardless of whether power to the device is OFF or ON. Use caution when working near these ports to avoid electric shock. When detaching cables, detach the end away from the SmartNode first.



Electrostatic Discharge: Always follow electrostatic discharge (ESD) prevention procedures when removing and replacing interface cards. Ensure that the SmartNode chassis is electrically connected to earth ground. Wear an ESD-preventive wrist strap, ensuring that it makes good skin contact. Connect the clip to earth ground to channel unwanted ESD voltages to ground safely. If no ESD wrist strap is available, ground yourself by touching the metal part of the chassis.

If you place an electronic component down on your bench, lay it on its shielded plastic bag.

Internal PM-48V-INT or PM-40V-INT line power module installation

Refer to the following and select the appropriate procedure based on whether you are installing a line power module into a SmartNode 2300 or SmartNode 2400:

- Installing the PM-48V-INT 48V power supply module into the SmartNode 2300 (see section “[SmartNode 2300 line power module installation](#)” on page 118)
- Installing the PM-40V-INT 40V power supply module into the SmartNode 2400 (see section “[SmartNode 2400 line power module installation](#)” on page 120)

SmartNode 2300 line power module installation

The 48V line power module is mounted inside the SmartNode 2300, next to the existing 12V power supply. You should not move the 12V power supply module from its installed location (see [figure 76](#) for 12V power supply location).

Note The 12V and the 48V line power modules are very similar in appearance. The 48V module is labeled *ZWS30-48* on the large electrolytic capacitor (see [figure 76](#)).



Connecting the 48V line power supply to the 12V socket instead of the 48V socket may result in permanent damage to the main board.

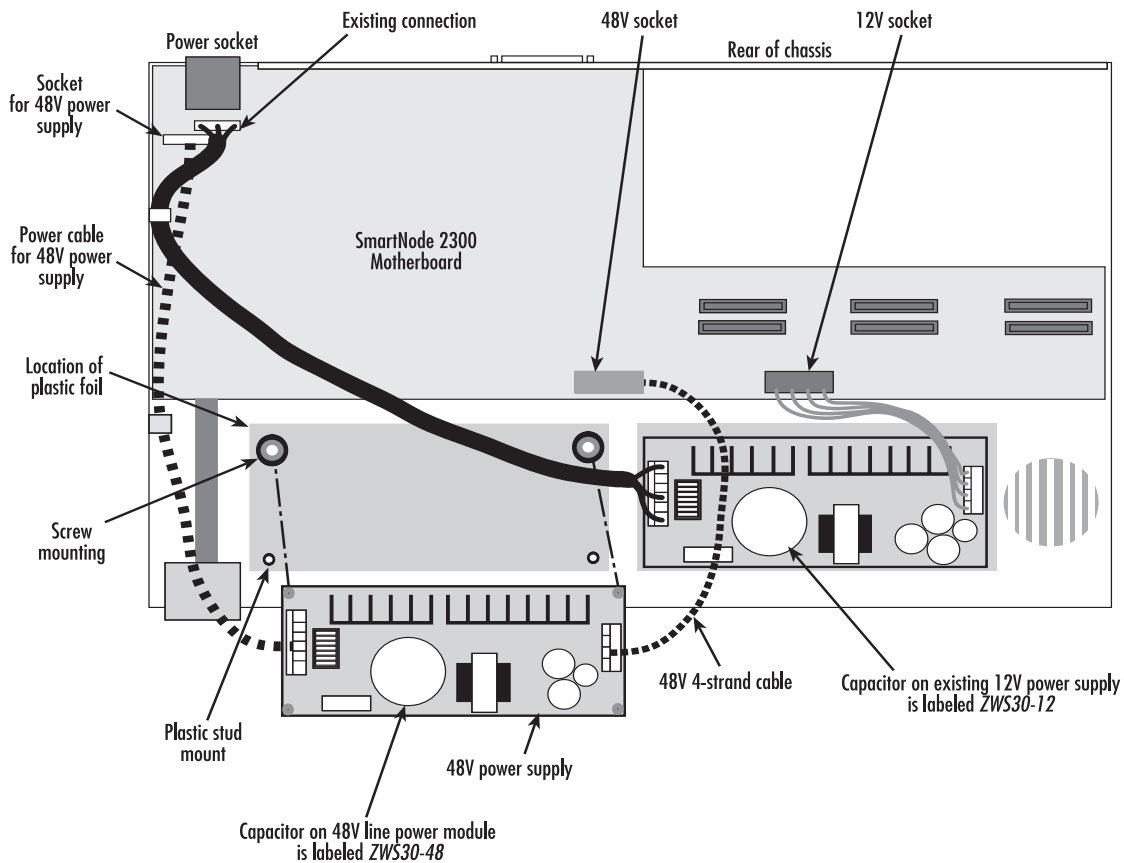

Figure 76. Internal 48V line power module and 12V power supply module locations in SmartNode 2300

If you look at the exposed SN2300 chassis, you will see the motherboard and the 12V power module that is already installed (see [figure 76](#)). (The figure shows the general arrangement of the chassis-mounted components only, with little or no component details. The IC-4BRV card is omitted for clarity). To the left of the existing 12V power module are two screw holes tapped into dimples, and two smaller holes. These four holes are for mounting the 48V line power module (see [figure 77](#)).

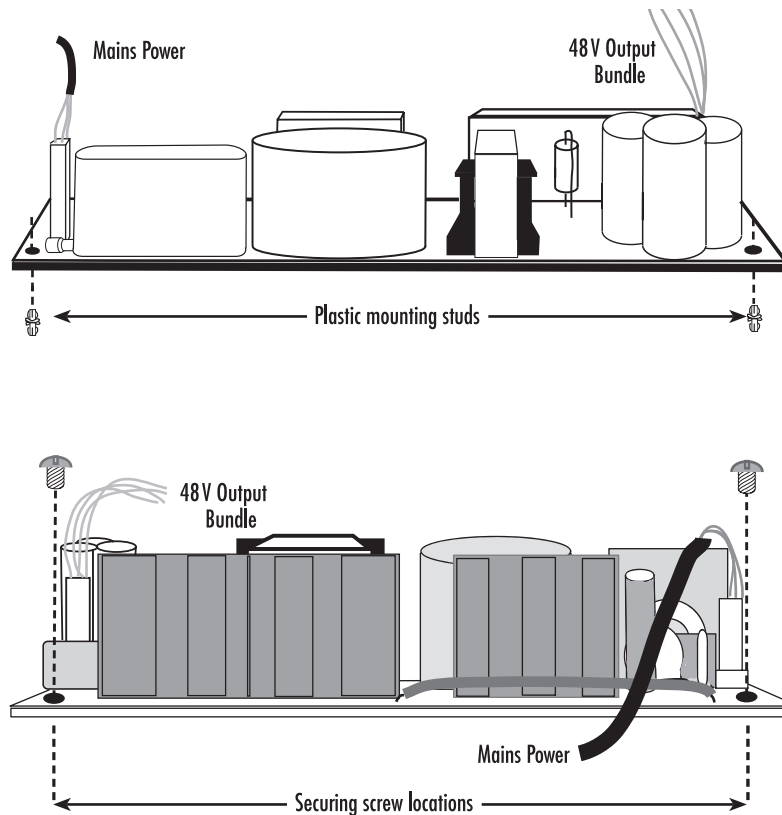

Figure 77. Fixing points: internal 48V (or 40V) line power module

Follow the steps below to mount a 48V internal line power module.

1. Remove the 48V line power module from its packing. Verify that the side of the largest electrolytic capacitor has the label ZWS30-48.
2. Position the plastic insulating foil over the four mounting holes in the SmartNode 2300 chassis.
3. Insert the plastic mounting studs into the line power module, one into each of the two corner holes that are on the opposite side to the finned heat sinks (see [figure 76](#) on page 118). Insert them from below.
4. Position the line power module so that the studs pass through the holes in the plastic foil and engage in the two chassis holes that are nearest to the front (LED) side of the SmartNode. Press down gently to secure.
5. From above, insert the screws into the module, one into each of the two holes at the corners of the heat-sink side. Screw them home so that the screws pass through the foil and secure the module onto the SmartNode chassis dimples. See the lower picture in [figure 77](#) on page 119.
6. First insert the white 4-lead 48V supply cable in the line power module's socket. Then connect it to the 48V socket on the motherboard. The plug is polarized so you cannot insert the sockets the wrong way round. See [figure 77](#) on page 119.
7. Take the mains lead and insert the plug into the motherboard socket. This is adjacent to the 230V external power socket. Insert the other end in the line power module's socket. All plugs are polarized so that they cannot be inserted the wrong way round. Clip the cable to the side of the chassis.

Go to section “[Completing the installation](#)” on page 121.

SmartNode 2400 line power module installation

The 40V line power module is mounted inside the SmartNode 2400, next to the existing 12V power supply. You should not move the 12V power supply module from its installed location (see [figure 78](#) for 12V power supply location).

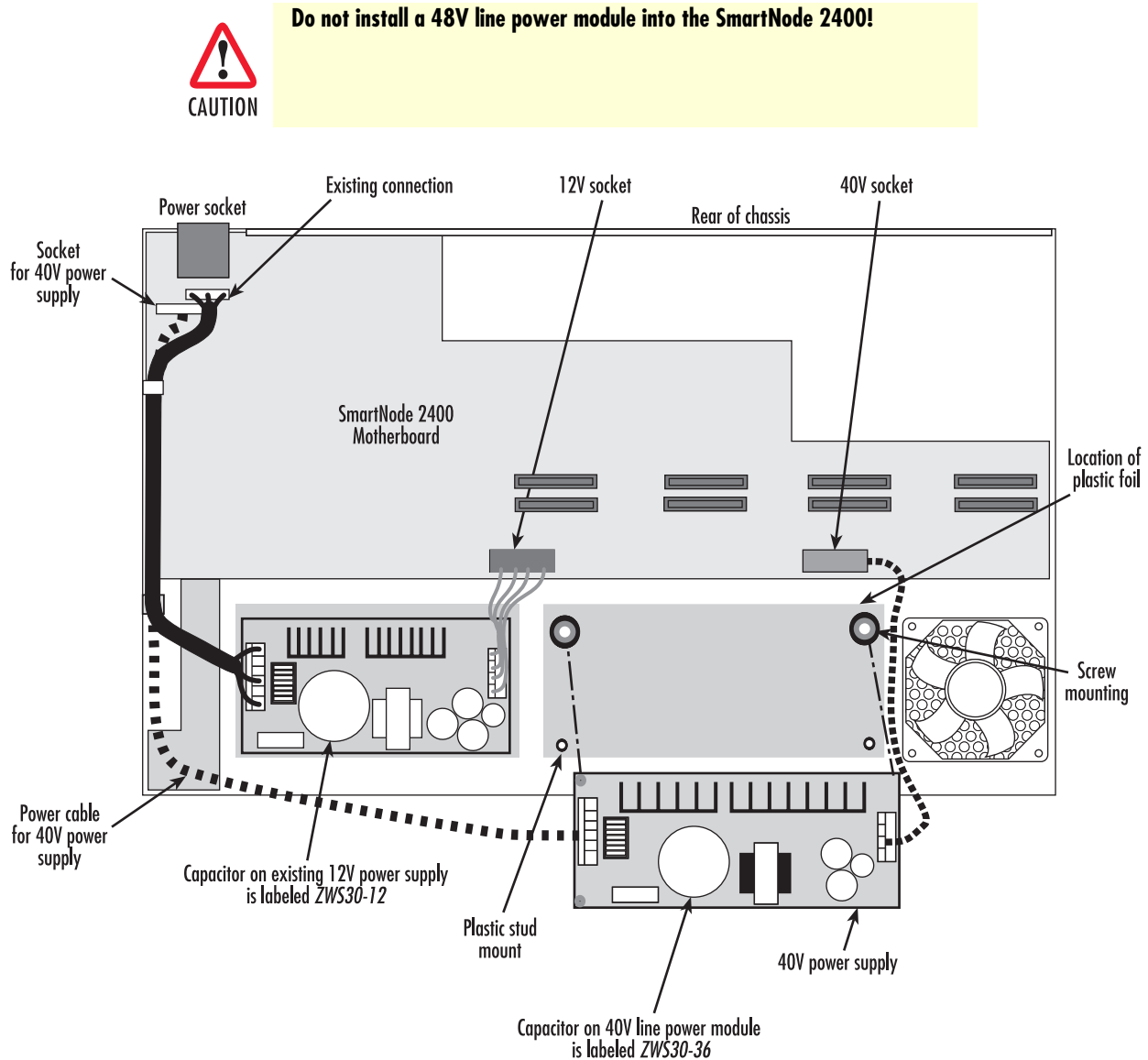

Figure 78. Internal 40V line power module and 12V power supply module locations in SmartNode 2400

Note The 12V and the 40V line power modules are very similar in appearance. The 40V module is labeled *ZWS30-36* on the large electrolytic capacitor (see [figure 78](#)).



Connecting the 40V line power supply to the 12V socket instead of the 40V socket may result in permanent damage to the main board.

If you look at the exposed SN2400 chassis, you will see the motherboard and the 12V power module that is already installed (see [figure 78](#)). (The figure shows the general arrangement of the chassis-mounted components only, with little or no component details.). To the right of the existing 12V power module are two screw holes tapped into dimples, and two smaller holes. These four holes are for mounting the 40V line power module (see [figure 77](#) on page 119).

Follow the steps below to mount a 40V internal line power module.

1. Remove the 40V line power module from its packing. Verify that the side of the largest electrolytic capacitor has the label *ZWS30-36*.
2. Position the plastic insulating foil over the four mounting holes in the SmartNode 2400 chassis.
3. Insert the plastic mounting studs into the line power module, one into each of the two corner holes that are on the opposite side to the finned heat sinks (see [figure 78](#) on page 120). Insert them from below.
4. Position the line power module so that the studs pass through the holes in the plastic foil and engage in the two chassis holes that are nearest to the front (LED) side of the SmartNode. Press down gently to secure.
5. From above, insert the screws into the module, one into each of the two holes at the corners of the heat-sink side. Screw them home so that the screws pass through the foil and secure the module onto the SmartNode chassis dimples. See the lower picture in [figure 77](#) on page 119.
6. First insert the white 4-lead 40V supply cable in the line power module's socket. Then connect it to the 40V socket on the motherboard. The plug is polarized so you cannot insert the sockets the wrong way round. See [figure 77](#) on page 119.
7. Take the mains lead and insert the plug into the motherboard socket. This is adjacent to the 230V external power socket. Insert the other end in the line power module's socket. All plugs are polarized so that they cannot be inserted the wrong way round. Clip the cable to the side of the chassis.

Go to section [“Completing the installation”](#).

Completing the installation

Once you have installed the 48V (or 40V) line power module and set the jumper pins, do the following:

1. Install the interface card in its expansion slot (see chapter 9, [“Interface card installation”](#) on page 123).
2. Close the case and insert the mains power supply lead.
3. Insert the network cables and observe the LED indications (see chapter 11, [“Monitoring Status”](#) on page 137). Test the correct functioning of the connections.

The maximum total power consumption of all ISDN devices connected to internally powered S0 ports is limited to 30W. If your connected devices need more power switch off the internal power connection for some ports by removing the corresponding jumpers, and use the external Phantom power supply (PM-BRI-EXT) unit on these ports. The external Phantom power supply and its connection is described in section [“External S-Bus power supply”](#). Jumper settings are described in section [“S-Bus line power”](#) on page 38.

External S-Bus power supply

Many ISDN telephone handsets require that 40 VDC power be supplied via the S-Bus connection. In other words, they have no separate or built-in power supply. In general point-to-multipoint ISDN BRI NTs supply line power to the S-Bus. Point-to-point NTs connected to a PBX in general do not supply line power.

If line power is not available from the NT, but required for connected terminals, the PM-BRI-EXT S-Bus Phantom power supply can be used.

Table 37. PM-BRI-EXT S-Bus 40V power supply

Item:	Phantom Power Supply; PM-BRI-EXT
Voltage Specifications:	Input 230VAC, Output 40VDC



The PM-BRI-EXT power supply unit is equipped with a transformer that is specially designed for S-Bus line power. The use of a general purpose DC power transformer may cause equipment damage.



If you use a Phantom power supply other than that supplied by Patton Electronics Co., you must ensure that it conforms to ITU I.430 Section 9.7.3.2.2. which specifies that the maximum current delivered shall not exceed 200mA.

Chapter 9 **Interface card installation**

Chapter contents

Introduction	125
Safety Recommendation	125
Installing interface cards	126
Card locating screws	127

Introduction

This chapter describes how to install interface cards in a SmartNode 2000 Series device.

Safety Recommendation

Follow these guidelines to ensure general safety:

- Keep the chassis area clear and dust-free during and after installation.
- Put the removed chassis cover in a safe place.
- Keep tools away from walk areas where you or others could fall over them.
- Do not wear loose clothing that could get caught in the electronic device or chassis.
- Do not perform any action that creates a potential hazard to people or that makes equipment unsafe.
- Before opening the chassis, disconnect all cables to avoid contact with hazardous voltages.



Mains Voltage: Do not open the case when the power cord is connected. Hazardous voltages exist in mains-connected cables. Do not touch power supply when the power cord is connected. Line voltages are present within the power supply when the power cord is connected.



Hazardous network voltages are present in WAN and telephone networks ports regardless of whether power to the device is OFF or ON. Use caution when working near these ports to avoid electric shock. When detaching cables, detach the end away from the SmartNode first.



Electrostatic Discharge: Always follow electrostatic discharge (ESD) prevention procedures when removing and replacing interface cards. Ensure that the SmartNode chassis is electrically connected to earth ground. Wear an ESD-preventive wrist strap, ensuring that it makes good skin contact. Connect the clip to earth ground to channel unwanted ESD voltages to ground safely. If no ESD wrist strap is available, ground yourself by touching the metal part of the chassis.

If you place an electronic component down on your bench, lay it on its shielded plastic bag.

Installing interface cards

Figure 79 depicts an example of a card installation in *SLOT 2* of a SmartNode 2000 Series device.

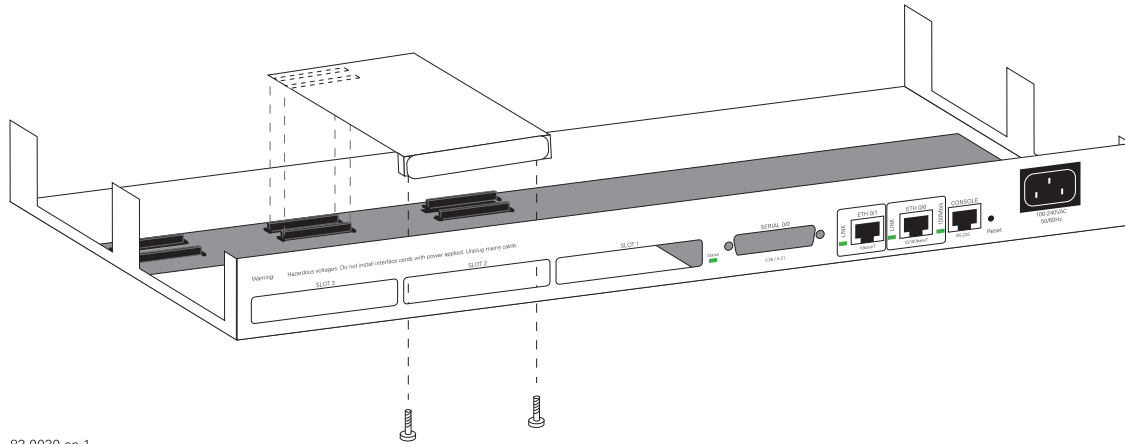

83-0030-en-1

Figure 79. Example card installation in SLOT 2

To install interface cards, do the following:

1. Remove all cables, including mains power cord, Ethernet and telephone network interface cables.
2. Put on an ESD wrist wrap to prevent electrostatic discharge.
3. Use a Phillips screwdriver to remove the cover of the SmartNode. There are a total of nine screws on a SmartNode 2300: three on each side, two on the top at the rear (connector-side) and one underneath at the front (LED) side. The SmartNode 2400 has six screws, two on each side, one on the top at the rear (connector-side) and one underneath at the front (LED) side.
4. Use a Phillips screwdriver to remove the blank filler panel from the expansion slot in which the interface card is to be installed. Save the blank panel for future use.
5. Move the front panel of the interface card into the expansion slot opening of the SmartNode until it fits correctly.
6. Press the interface card gently down until you feel its connector mate securely with the socket on the motherboard. Take great care to ensure that the card fits correctly in the connector and is pressed fully home.
7. Secure the interface card by replacing the 2 screws into the holes on the bottom of the SmartNode, using the Phillips screwdriver (see section “[Card locating screws](#)” on page 127).
8. Replace the cover and secure it to the side panels of the SmartNode chassis by the screws that you removed in step 3.
9. Install the cables you removed in step 1, then connect the installed interface card cables.

Card locating screws

Figure 80 shows part of the under side of the SmartNode 2300 with the arrangement of securing screws for two of the three interface cards. The two outer expansion slots (*SLOT 1*, *SLOT 3*) have each a single securing screw towards the inner sides. *SLOT 2* has two securing screws. (SLOT 1 is similar to SLOT 3 and so is not shown). You can see the location of an extension card's screw holes in the metal blocks on either side of the group of four sockets in the jumper pin setting diagrams, which depict the underside of the IC-4BRV interface card and can be seen in the IC-4BRV chapter.

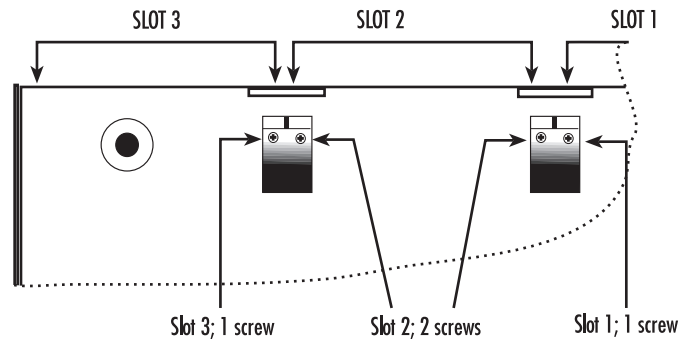

Figure 80. SmartNode 2300 expansion slots: securing screws for interface cards

Chapter 10 **Getting Started with the SmartNode Device**

Chapter contents

Introduction	131
1. Configure IP address	132
Power connection and default configuration	132
Connect with the serial interface	132
Login	133
Changing the IP address	133
2. Connect the SmartNode to the network	134
3. Load configuration	134
Additional information	135

Introduction

This chapter leads you through the basic steps to set up a new SmartNode and to download a configuration.

Patton SmartNodes can be used for a wide variety of IP-based network applications. To support and ease the configuration of the SmartNodes configuration, templates for the most important applications are available on the Patton server at www.patton.com/voip.

The main steps for setting up a new SmartNode (as of release 2.00 or 2.10) are shown in [figure 81](#).

1 Configure IP address

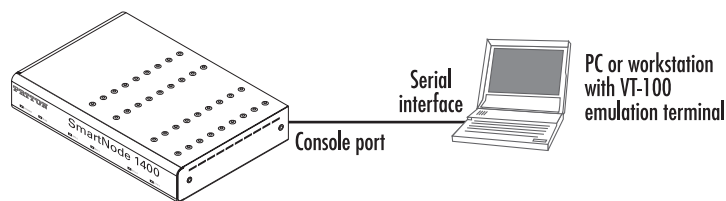

2 Connect the SmartNode to the network

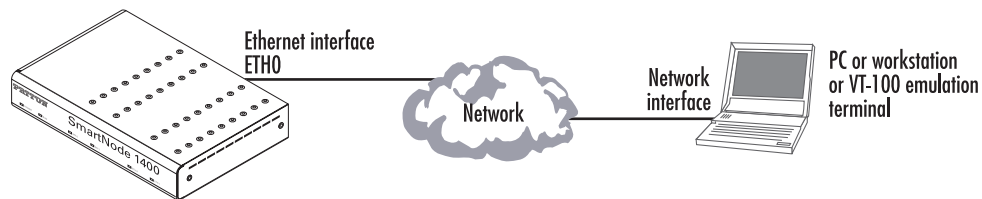

3 Load configuration

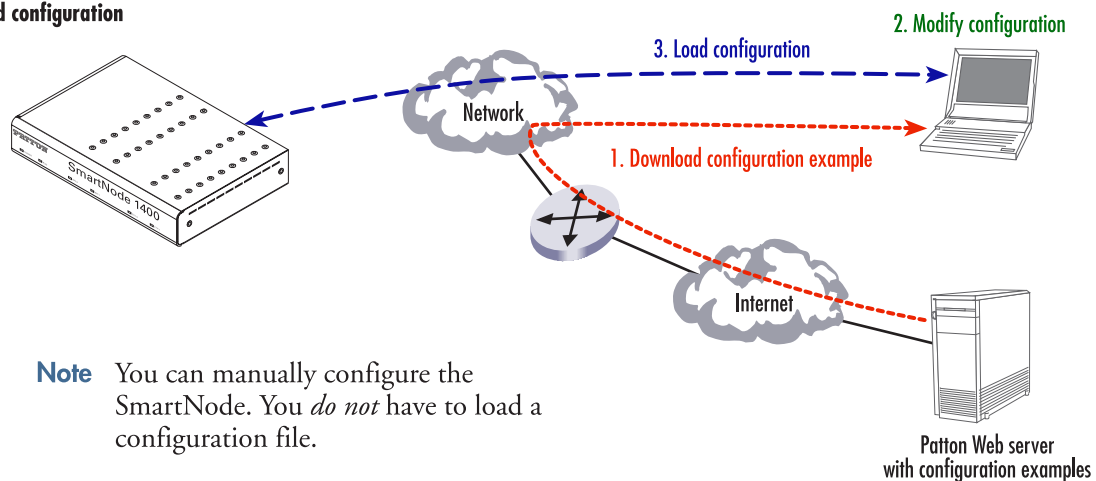

Note You can manually configure the SmartNode. You *do not* have to load a configuration file.

Figure 81. Steps for setting up a new SmartNode

1. Configure IP address

Power connection and default configuration

First the SmartNode must be connected to the mains power supply with the power cable. Wait until the *Run* LED stops blinking and lights constantly. Now the SmartNode is ready.

The factory default configuration for the Ethernet interface IP addresses and network masks are listed in [table 38](#).

Table 38. Factory default IP address and network mask configuration

	IP Address	Network Mask
Interface Ethernet 0 (ETH0)	172.16.40.1	255.255.0.0
Interface Ethernet 1 (ETH1)	192.168.1.1	255.255.255.0

Both Ethernet interfaces are activated upon power-up.

If these addresses match with those of your network, go to section “2. Connect the SmartNode to the network” on page 134. Otherwise, refer to the following sections to change the addresses and network masks.

Connect with the serial interface

The *Console* port is wired as an EIA-561, RS-232 port. Use the included Model 16F-561 adapter and cable (see [figure 82](#)) between the SmartNode’s *Console* port and a PC or workstation’s RS-232 serial interface. Activate the terminal emulation program on the PC or workstation that supports the serial interface (e.g. HyperTerm).

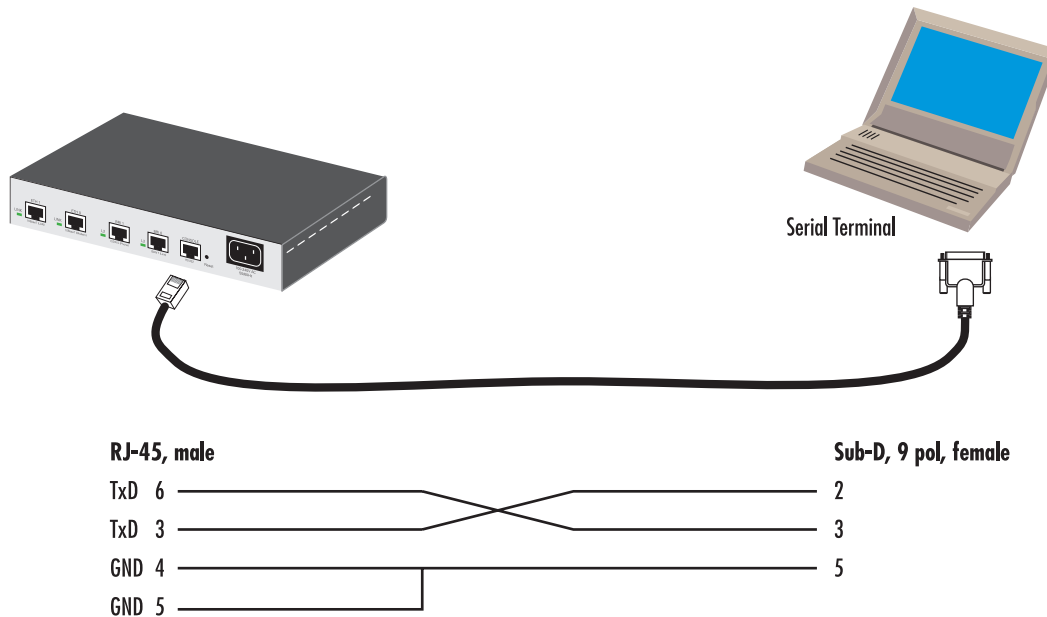

Figure 82. Connecting to the terminal

Terminal emulation program settings:

- 9600 baud
- no parity

- 8 bit
- 1 stop bit
- 1 start bit
- No flow control

Login

Accessing your SmartNode via the local console port (or via a Telnet session) causes the login screen to display. Type the factory default login: *administrator* and leave the password empty. Press the *Enter* key after the password prompt.

```
login:administrator
password: <Enter>
172.16.40.1>
```

After you have successfully logged in you are in the operator execution mode, indicated by > as command line prompt. With the commands *enable* and *configure* you enter the configuration mode.

```
172.16.40.1>enable
172.16.40.1#configure
172.16.40.1(cfg)#
```

Changing the IP address

Select the context IP mode to configure an IP interface.

```
172.16.40.1(cfg)#context ip router
172.16.40.1(ctx-ip)[router]#
```

Now you can set your IP address and network mask for the interface *eth0*. Within this example a class C network (172.16.1.0/24) is assumed. The IP address in this example is set to *172.16.1.99* (you should set this to an unused IP address on your network).

```
172.16.40.1(ctx-ip)[router]#interface eth0
172.16.40.1(if-ip)[eth0]#ipaddress 172.16.1.99 255.255.255.0
2002-10-29T00:09:40 : LOGINFO    : Link down on interface eth0.
2002-10-29T00:09:40 : LOGINFO    : Link up on interface eth0.
172.16.1.99(if-ip)[eth0]#
```

Copy this modified configuration to your new start-up configuration. Upon the next start-up the system will initialize itself using the modified configuration.

```
172.16.1.99(if-ip)[eth0]#copy running-config startup-config
172.16.1.99(if-ip)[eth0]#
```

The SmartNode can now be connected with your network.

2. Connect the SmartNode to the network

Depending whether you connect the SmartNode to a host directly or via a hub or switch either straight-through wired or cross-over cables must be used (see figure 83).

Note The SmartNode 4520 Series is equipped with Auto-MDX Ethernet ports. Use straight-through or cross-over cables for host or hub/switch connections. The SmartNode 4110 will require the proper cable as it does not have the MDX feature.

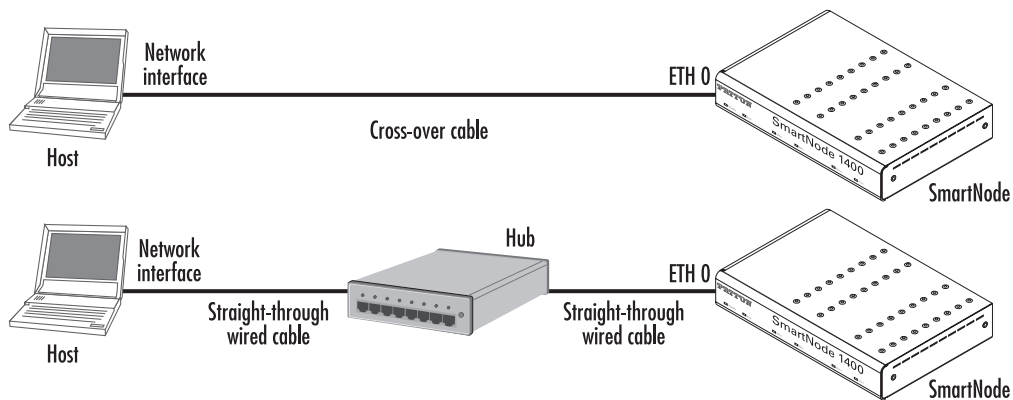

Figure 83. Connecting the SmartNode to the network

You can check the connection with the ping command to another host on the local LAN.

```
172.16.1.99(if-ip)[eth0]#ping <IP Address of the host>
```

Respectively from the host: *ping 172.16.1.99*

Note To ping outside your local LAN, you will need to configure the default gateway.

3. Load configuration

Download a configuration note to your PC from the support page of the Patton-Inalp web server (<http://www.inalp.ch/en/support/confignotes/>), which matches your application. Adapt the configuration as described in the configuration note to your network (do not forget to modify the IP address) and copy the modified configuration to a TFTP server. The SmartNode can now load its configuration from this server.

In this example we assume the TFTP server on the host with the IP address 172.16.1.11 and the configuration named *SN.cfg* in the root directory of the TFTP server.

```
172.16.1.99(if-ip)[eth0]#copy tftp://172.16.1.11/SN.cfg startup-config
Download...100%
172.16.1.99(if-ip)[eth0]#
```

After the SmartNode has been rebooted the new start up configuration will be activated.

```
172.16.1.99(if-ip)[eth0]#reload
Running configuration has been changed.
Do you want to copy the 'running-config' to the 'startup-config'?
Press 'yes' to store, 'no' to drop changes : no
```

Press 'yes' to restart, 'no' to cancel : yes

The system is going down

Additional information

For detailed information about configuring and operating guidance, set up procedures, and troubleshooting, refer to the *Software Configuration Guide* on the enclosed CD-ROM. On the CD you will also find a freeware TFTP server, which is also available from the <http://solarwinds.net/> web site.

Chapter 11 **Monitoring Status**

Chapter contents

Status LEDs.....139

Status LEDs

The LEDs on the SmartNode provide information about the status of the device and its interfaces. They are located on both the front and the rear of the device. Indication is conveyed by [on / off] and [steady / blinking] states, not by color change. Depending on the type of SmartNode that you have installed, some LEDs may not be available.

There are five possible states for a SmartNode:

- Normal boot process (Normal Boot). The SmartNode starts the normal application, that is the configuration stored in the flash memory.
- Normal operating behavior (Normal Run). The SmartNode is running the normal application that is the configuration stored in the flash memory.
- Boot loader started (Boot Loader). The boot loader started instead of the normal application. Refer to the Software Configuration Guide for more details of the boot loader.
- Default download in progress (Default Download). A configuration file is downloaded for the first time to the flash memory, i.e. the configuration file default-config in the storing location nvram: does not exist yet. It means that a configuration file is being downloaded.
- Error state (Error State)

If neither the normal application nor the boot loader are running, the device may have a more serious problem. The error state is indicated by the LEDs as described in [table 39](#).

Table 39. SmartNode LED Indications

LED	Normal Boot	Normal Run	Boot Loader	Default Download	Error State
PWR (Power)	On	On	On	On	On
RUN	On–Off ^a	On	Off	Off	Blinking ^b
ACT	On–Off ^a	Blinking ^c	Blinking ^b	On	Off
BRI x	On–Off ^a	On ^d	Blinking ^b	On	Off
ETH x^e	On–Off ^a	Blinking ^f	Off	Blinking ^e	Off
LINK	Off	On ^g	Off	On ^f	Off
L2	Off	On ^f	Off	Off	Off
100Mbps	Off	On ^h	Off	Off	Off
STATUS	Not Used	Not Used	Not Used	Not Used	Not Used

- 1 sec ON, then OFF
- 500ms ON, 500ms OFF
- Blinks according to CPU load
- ON if one or more B-Channels are active on the BRI interface
- BRI 1 and BRI 2 blink when interconnected (fallback) on interface card IC-4BRV
- Blinks according to IP activity
- ON if correctly connected to an active ISDN device
- ON if connected to a 100Mbps Ethernet device, OFF otherwise

Chapter 12 **Contacting Patton for assistance**

Chapter contents

- Introduction143
- Contact information143
- Warranty Service and Returned Merchandise Authorizations (RMAs)143
 - Warranty coverage143
 - Out-of-warranty service143
 - Returns for credit143
 - Return for credit policy144
- RMA numbers144
 - Shipping instructions144

Introduction

This chapter contains the following information:

- “[Contact information](#)”—describes how to contact PATTON technical support for assistance.
- “[Warranty Service and Returned Merchandise Authorizations \(RMAs\)](#)”—contains information about the RAS warranty and obtaining a return merchandise authorization (RMA).

Contact information

Patton Electronics offers a wide array of free technical services. If you have questions about any of our other products we recommend you begin your search for answers by using our technical knowledge base. Here, we have gathered together many of the more commonly asked questions and compiled them into a searchable database to help you quickly solve your problems:

- Online support—available at www.patton.com
- E-mail support—e-mail sent to support@patton.com will be answered within 1 business day
- Telephone support—standard telephone support is available 5 days a week, from 8:00 am to 5:00 pm EST (1300 to 2200 UTC) by calling +1 (301) 975-1007

Warranty Service and Returned Merchandise Authorizations (RMAs)

Patton Electronics is an ISO-9001 certified manufacturer and our products are carefully tested before shipment. All of our products are backed by a comprehensive warranty program.

Note If you purchased your equipment from a Patton Electronics reseller, ask your reseller how you should proceed with warranty service. It is often more convenient for you to work with your local reseller to obtain a replacement. Patton services our products no matter how you acquired them.

Warranty coverage

Our products are under warranty to be free from defects, and we will, at our option, repair or replace the product should it fail within one year from the first date of shipment. Our warranty is limited to defects in workmanship or materials, and does not cover customer damage, lightning or power surge damage, abuse, or unauthorized modification.

Out-of-warranty service

Patton services what we sell, no matter how you acquired it, including malfunctioning products that are no longer under warranty. Our products have a flat fee for repairs. Units damaged by lightning or other catastrophes may require replacement.

Returns for credit

Customer satisfaction is important to us, therefore any product may be returned with authorization within 30 days from the shipment date for a full credit of the purchase price. If you have ordered the wrong equipment or you are dissatisfied in any way, please contact us to request an RMA number to accept your return. Patton is not responsible for equipment returned without a Return Authorization.

Return for credit policy

- Less than 30 days: No Charge. Your credit will be issued upon receipt and inspection of the equipment.
- 30 to 60 days: We will add a 20% restocking charge (crediting your account with 80% of the purchase price).
- Over 60 days: Products will be accepted for repairs only.

RMA numbers

RMA numbers are required for all product returns. You can obtain an RMA by doing one of the following:

- Completing a request on the RMA Request page in the *Support* section at www.patton.com
- By calling +1 (301) 975-1000 and speaking to a Technical Support Engineer
- By sending an e-mail to returns@patton.com

All returned units must have the RMA number clearly visible on the outside of the shipping container. Please use the original packing material that the device came in or pack the unit securely to avoid damage during shipping.

Shipping instructions

The RMA number should be clearly visible on the address label. Our shipping address is as follows:

Patton Electronics Company

RMA#: xxxx

7622 Rickenbacker Dr.

Gaithersburg, MD 20879-4773 USA

Patton will ship the equipment back to you in the same manner you ship it to us. Patton will pay the return shipping costs.

Appendix A **Specifications**

Chapter contents

Physical description	147
SN1200	147
SN1400	147
SN2300	147
SN2400	147
IC-4BRV	148
IC-E1V	148
IC-4FXS	148
Line power module	148

Physical description

SN1200

- Chassis dimensions: 8.7W x 1.6H x 6.3D in. (220W x 40H x 160D mm)
- Weight: 600 g
- CPU Motorola MPC850 @ 50MHz
- Memory 16 Mb SDRAM
- Flash memory 4 Mb
- 2-channel DSP
- Power dissipation 4 W
- Power supply AC 100–240 VAC, 50/60 Hz, 70 mA

SN1400

- Chassis W / H / D: 220 / 40 / 160 mm
- Weight: 600 g
- CPU Motorola MPC850 @ 50MHz
- Memory 16 Mb SDRAM
- Flash 4 Mb
- 4-channel DSP
- Power dissipation 4 W
- Power supply AC 100–240 VAC, 50/60 Hz, 70 mA

SN2300

- Chassis W/H/D 440 / 42 / 265 mm
- Weight 1650g
- CPU Motorola MPC860 @ 50 MHz
- Memory 16 MB SDRAM
- Flash 4 MB
- Power dissipation 30 W, fully loaded interface card (IC) slots, without internal 48V (or 40V) Line Power Module PM-48V-INT (or PM-40V-INT)
- Power supply AC 100 - 240 V, 50/60 Hz , max. 1.0 A

SN2400

- Chassis W/H/D 440 / 42 / 265 mm
- Weight 1650g
- CPU Motorola MPC750 @ 333 MHz

- Memory 32 MB SDRAM, up to 128MB SO-DIMM
- Flash 8 MB
- Power dissipation 30 W, fully loaded interface card (IC) slots, without internal 48V (or 40V) Line Power Module PM-48V-INT (or PM-40V-INT)
- Power supply AC 100 - 240 V, 50/60 Hz, max. 1.0A or DC 48V, max. 2A

IC-4BRV

W / H / D: 149 / 13.5 / 74 mm

Weight: 100 g

PMC card with 32bit PCI bus

CPU Motorola MPC850 @ 50 MHz

Memory 8MB SDRAM

Power dissipation < 3W

Optional internal Line Power Module PM-48V-INT (or PM-40V-INT): up to 2.5W per BRI port

IC-E1V

- Size W / H / D: 149 / 13.5 / 74 mm
- Weight: 80 g
- PMC card with 32bit PCI bus
- CPU Motorola MPC850 @ 50 MHz
- Memory 8MB SDRAM
- Power dissipation 2,5W

IC-4FXS

- W / H / D: 149 / 13.5 / 74 mm
- Weight: 100 g
- PMC card with 32bit PCI bus
- CPU Motorola MPC850 @ 50 MHz
- Memory 8MB SDRAM
- Power dissipation < 3W
- Requires internal Line Power Module PM-48V-INT (or PM-40V-INT) to generate ringing and loop voltages

Line power module

- Input: 230VAC
- Output: 48V (or 40V) DC 30W

Appendix B **Cabling**

Chapter contents

Introduction	151
Serial console	151
Ethernet 10Base-T and 100Base-T	152
V.35 and X.21	152
BRI	154
E1 PRI	156
T1 PRI	157

Introduction

This section provides information on the cables used to connect the SmartNode and the interface cards to the existing network infrastructure and to third party products.

Serial console

The SmartNode can be connected to a serial terminal over its serial console port, as depicted in [figure 84](#).

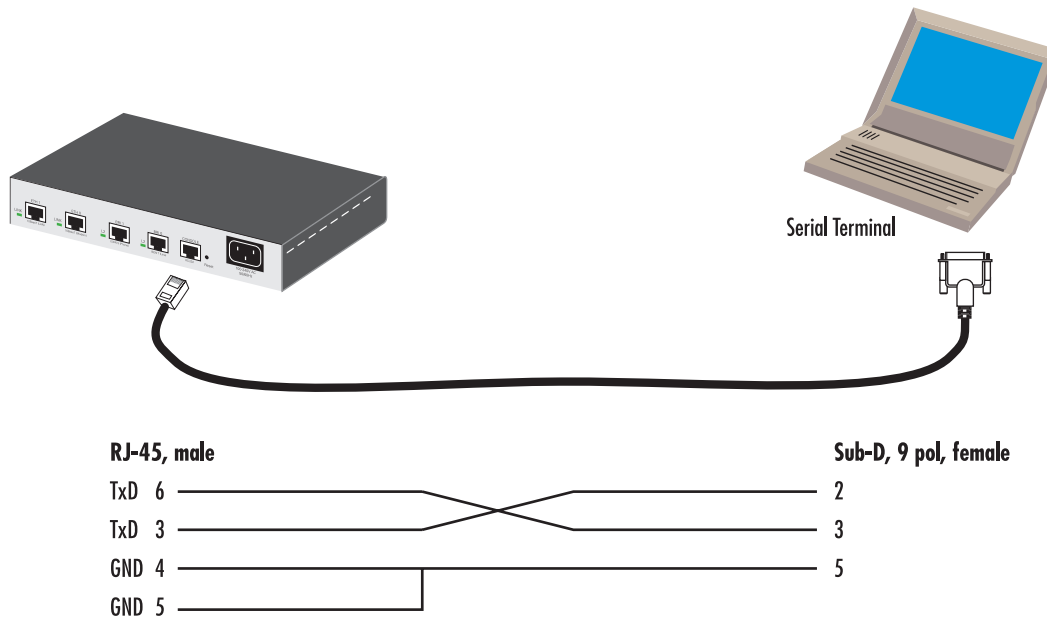

Figure 84. Connecting a serial terminal

Ethernet 10Base-T and 100Base-T

Ethernet devices (10Base-T/100Base-T) are connected to the SmartNode or to an interface card over a cable with RJ-45 plugs. Use a cross-over cable to a host, or a straight cable to a hub. See [figure 85](#) (host) and [figure 86](#) (hub) for the different connections.

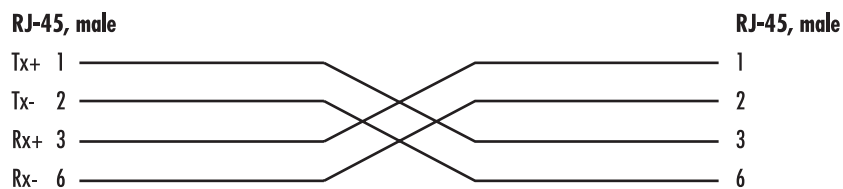
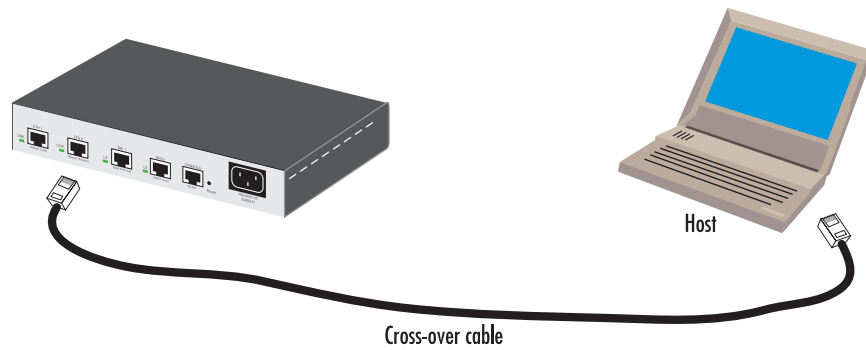

Figure 85. Connecting a host

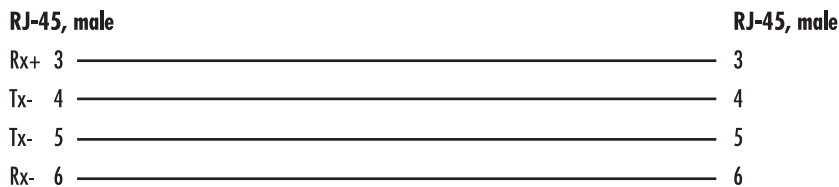
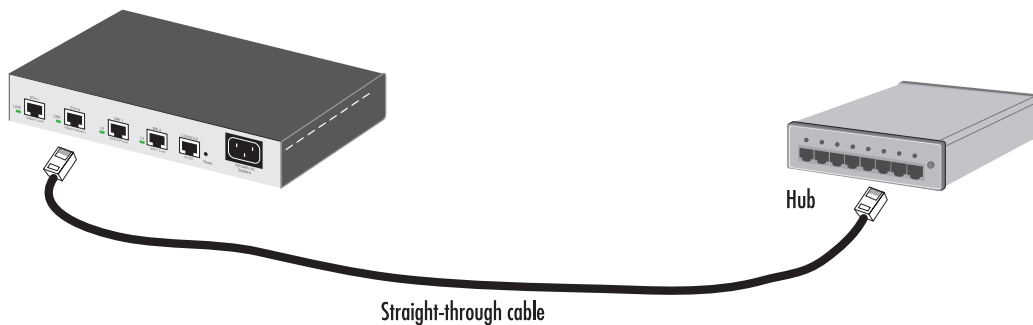

Figure 86. Connecting a hub

V.35 and X.21

[Figure 87](#) on page 153 shows the cables that are required to connect the serial port of a SmartNode to a standard X.21 or V.35 network termination unit (NTU).

Note Some NTUs have non-standard or mirrored connections and require special cables. Consult the NTU maker's product documentation.

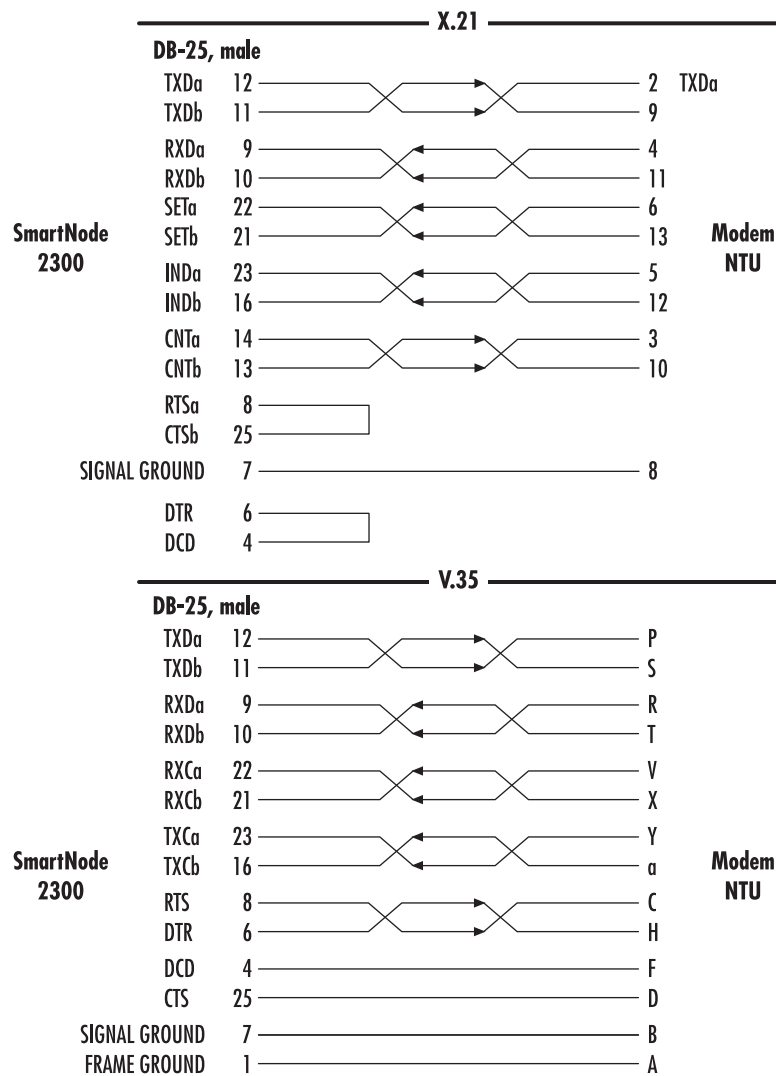
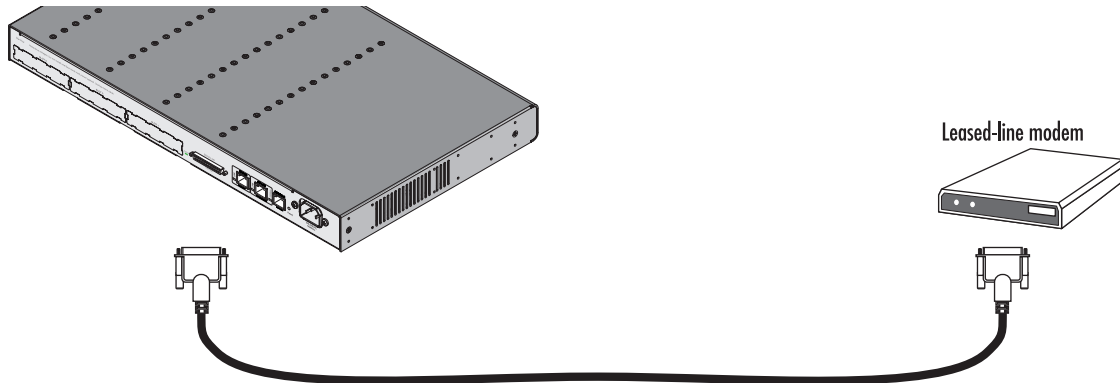

Figure 87. V.35 and X.21 modem connection

BRI

A straight-through S-Bus cable with RJ-45 plugs is used to connect an ISDN NT or TE to the SmartNode or interface card. See [figure 88](#) (telephone connection) and [figure 89](#) on page 155 (NT connection) for the appropriate information. For BRI ports with configurable pin outs ensure that the appropriate mode (NET or USR) is configured.



Hazardous network voltages are present in the BRI cables. If you detach the cable, detach the end away from the SmartNode or interface card first to avoid possible electric shock. Network hazardous voltages may be present on the device in the area of the BRI port, regardless of when power is turned OFF.



To prevent damage to the system, make certain you connect the BRI cable to the BRI port only and not to any other RJ-45 socket.

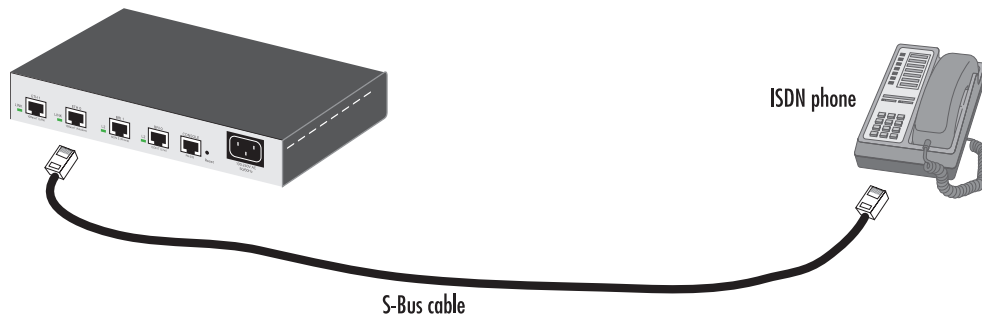

RJ-45, male		RJ-45, male
Rx+ 3	_____	3
Tx- 4	_____	4
Tx- 5	_____	5
Rx- 6	_____	6

Figure 88. Connecting a BRI to an ISDN telephone

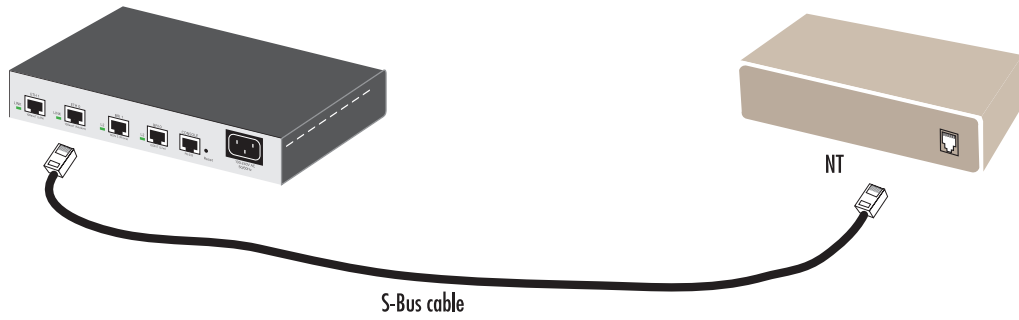

RJ-45, male		RJ-45, male	
Rx+	3	3	3
Tx-	4	4	4
Tx-	5	5	5
Rx-	6	6	6

Figure 89. Connecting a BRI to an NT

E1 PRI

The E1 PRI is usually connected to a PBX or switch—local exchange (LE). Type and pin outs of these devices vary depending on the manufacturer. In most cases, a straight-through RJ-45 to RJ-45 can be used to connect the PRI with a PBX. A cross-over cable is required to connect to a NT1, as illustrated in [figure 90](#) on page 156.



Hazardous network voltages are present in the PRI cables. If you detach the cable, detach the end away from the SmartNode or interface card first to avoid possible electric shock. Network hazardous voltages may be present on the device in the area of the PRI port, regardless of when power is turned OFF.



To prevent damage to the system, make certain you connect the PRI cable to the PRI port only and not to any other RJ-45 socket.

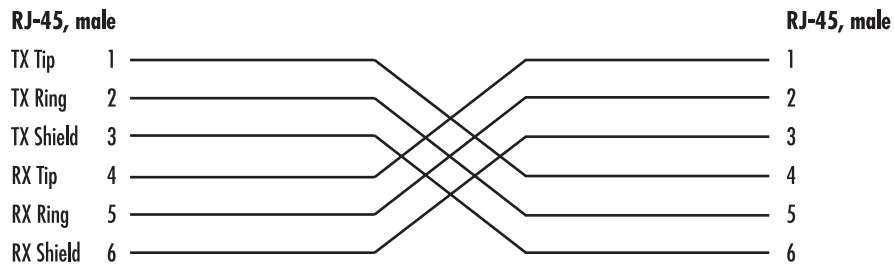
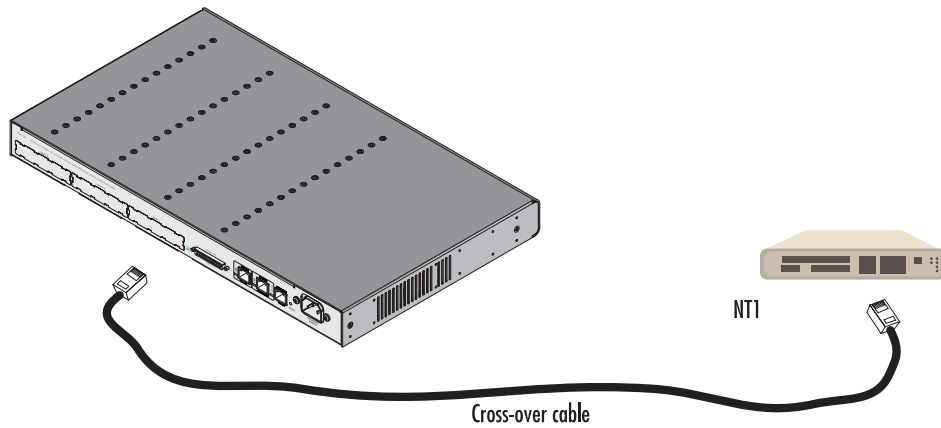

Figure 90. Connecting an E1 PRI port to an NT1

T1 PRI

The T1 PRI is usually connected to a PBX or switch—local exchange (LE). Type and pin outs of these devices vary depending on the manufacturer. In most cases, a straight-through RJ-45 to RJ-45 can be used to connect the PRI with a PBX. A cross-over cable is required to connect to a NT2, as illustrated in [figure 91](#) on page 157.



WARNING

Hazardous network voltages are present in the PRI cables. If you detach the cable, detach the end away from the SmartNode or interface card first to avoid possible electric shock. Network hazardous voltages may be present on the device in the area of the PRI port, regardless of when power is turned OFF.



WARNING

To prevent damage to the system, make certain you connect the PRI cable to the PRI port only and not to any other RJ-45 socket.

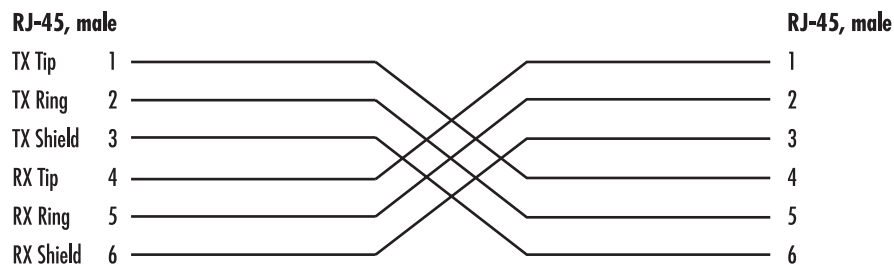
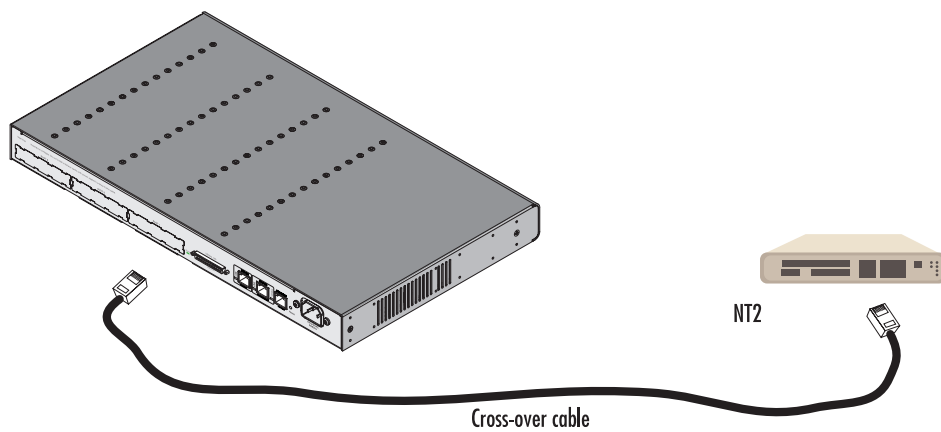

Figure 91. Connecting an T1 PRI port to an NT2

Appendix C **Port pin-outs**

Chapter contents

Introduction.....	161
Console port.....	161
Ethernet 10Base-T and 100Base-T port.....	161
BRI port.....	161
FXS port.....	162
PRI port.....	162
Serial port.....	163

Introduction

This section provides pin out information for the ports of the SmartNode and its interface cards.

Console port

Table 40. RJ-45 socket

Pin	Signal
3	TxD
4	GND
5	GND
6	RxD

Note Pins not listed are not used.

Ethernet 10Base-T and 100Base-T port

Table 41. RJ-45 socket

Pin	Signal
1	TX+
2	TX-
3	RX+
6	RX-

Note Pins not listed are not used.

BRI port

Table 42. RJ-45 socket

Pin	Signal (USR)	Signal (NET)
3	TX+	RX+
4	RX+	TX+
5	RX-	TX-
6	TX-	RX-

Note Pins not listed are not used.

FXS port

Table 43. RJ-12 socket

Pin	Signal
3	Ring (-)
4	Tip (+)

Note The IC-4FXS is actually equipped with RJ-11 sockets. An RJ-11 socket is similar to an RJ-12 socket but pins 1 and 6 are omitted.

Note Pins not listed are not used.

PRI port

Table 44. RJ-45 socket

Pin	USR
1	TX Tip
2	TX Ring
3	TX Shield
4	RX Tip
5	RX Ring
6	RX Shield

Note Pins not listed are not used.

Serial port

The serial port is configurable to work in either V.35 or in X.21 mode. A standard D-subminiature female socket with 25 positions is used.

Table 45. Serial port V.35 signals

Pin	Signal V.35
1	Frame Ground
4	DCD
6	DTR
7	Signal Ground
8	RTS
9	RXD _a
10	RXD _b
11	TXD _b
12	TXD _a
16	TXC _b
21	RXC _b
22	RXC _a
23	TXC _a
25	CTS

Note Pins not listed are not used.

Table 46. Serial port X.21 signals

Pin	Signal X.21
7	Signal Ground
9	RXD _a
10	RXD _b
11	TXD _b
12	TXD _a
13	CNT _b
14	CNT _a
16	IND _b
21	SET _b
22	SET _a
23	IND _a

Note Pins not listed are not used.