

# SmartNode 4400 IpChannel Bank

## Getting Started Guide



### Important

This is a Class A device and is intended for use in a light industrial environment. It is not intended nor approved for use in an industrial or residential environment.

Sales Office: +1 (301) 975-1000  
Technical Support: +1 (301) 975-1007  
E-mail: [support@patton.com](mailto:support@patton.com)  
WWW: [www.patton.com](http://www.patton.com)

Part Number: **07MSN4400-GS, Rev. D**  
Revised: **December 9, 2011**

**Patton Electronics Company, Inc.**

7622 Rickenbacker Drive  
Gaithersburg, MD 20879 USA  
Tel: +1 (301) 975-1000  
Fax: +1 (301) 869-9293  
Support: +1 (301) 975-1007  
Web: [www.patton.com](http://www.patton.com)  
E-mail: [support@patton.com](mailto:support@patton.com)

**Trademark Statement**

The terms *SmartNode*, *SmartWare*, and *SmartView* are trademarks of Patton Electronics Company. All other trademarks presented in this document are the property of their respective owners.

**Copyright © 2010-2011, Patton Electronics Company. All rights reserved.**

The information in this document is subject to change without notice. Patton Electronics assumes no liability for errors that may appear in this document.

**Important Information**

To use virtual private network (VPN) and/or AES/DES/3DES encryption capabilities with the SmartNode 4400, you may need to purchase additional licenses, hardware, software, network connection, and/or service. Contact [sales@patton.com](mailto:sales@patton.com) or +1 (301) 975-1000 for assistance.

**Warranty Information**

The software described in this document is furnished under a license and may be used or copied only in accordance with the terms of such license. For information about the license, see [Appendix E, "End user license agreement"](#) on page 63 or go to [www.patton.com](http://www.patton.com).

Patton Electronics warrants all SmartNode router components to be free from defects, and will—at our option—repair or replace the product should it fail within one year from the first date of the shipment.

This warranty is limited to defects in workmanship or materials, and does not cover customer damage, abuse or unauthorized modification. If the product fails to perform as warranted, your sole recourse shall be repair or replacement as described above. Under no condition shall Patton Electronics be liable for any damages incurred by the use of this product. These damages include, but are not limited to, the following: lost profits, lost savings and incidental or consequential damages arising from the use of or inability to use this product. Patton Electronics specifically disclaims all other warranties, expressed or implied, and the installation or use of this product shall be deemed an acceptance of these terms by the user.

# Summary Table of Contents

- 1 General information ..... 14
- 2 Applications overview..... 20
- 3 Hardware installation..... 23
- 4 Getting started with the SmartNode 4400 Series..... 34
- 5 Contacting Patton for assistance ..... 44
- A Compliance information ..... 47
- B Specifications ..... 49
- C Port pin-outs ..... 55
- D Factory Configuration ..... 61
- E End user license agreement ..... 63
- F Installation checklist ..... 66
- G Accessories ..... 68

# Table of Contents

<b>Summary Table of Contents .....</b>	<b>3</b>
<b>Table of Contents .....</b>	<b>4</b>
<b>List of Figures .....</b>	<b>7</b>
<b>List of Tables .....</b>	<b>8</b>
<b>About this guide .....</b>	<b>9</b>
Audience.....	9
Structure.....	9
Precautions .....	10
Safety when working with electricity .....	11
Preventing Electrostatic Discharge Damage .....	12
General observations .....	12
Typographical conventions used in this document.....	13
General conventions .....	13
<b>1 General information .....</b>	<b>14</b>
SmartNode 4400 Series overview.....	15
SmartNode 4400 Series detailed description.....	16
SmartNode 4400 Series front panel .....	17
SmartNode 4400 Series rear panels .....	18
Reset button behavior .....	19
<b>2 Applications overview.....</b>	<b>20</b>
Introduction.....	21
SmartNode 4400 Series applications.....	21
Enterprise FXS concentration and extension over IP and T1/E1 .....	21
Bulk analog line extensions .....	22
Legacy MTU/MDU migration to VoIP based networks .....	22
<b>3 Hardware installation.....</b>	<b>23</b>
Introduction.....	24
Planning the installation.....	24
Installation checklist .....	25
Site log .....	25
Network information .....	26
Network diagram .....	26
IP related information .....	26
Configuration tools .....	26
AC Power Mains .....	26
Location and mounting requirements .....	27
Installing the IpChannel Bank.....	27
Unpacking the Model SN4400 series IpChannel Bank .....	27
IpChannel Bank chassis installation .....	27

Connecting cables .....	28
Connecting the FXS ports .....	28
Connecting the Ethernet ports .....	28
Connecting the 10/100Base-T Ethernet ports to an Ethernet switch or hub .....	29
Connecting a 10/100Base-T Ethernet port to an Ethernet-capable workstation .....	29
Connecting the EIA-561 RS-232 configuration port (DCE configured) .....	30
Connecting power .....	30
Grounding the Model SN4400—AC and DC units .....	30
Installing the power cables—AC units .....	31
Installing the power cables—DC units .....	32
<b>4 Getting started with the SmartNode 4400 Series.....</b>	<b>34</b>
Introduction.....	35
1. Configure IP address .....	36
Factory-default IP settings .....	36
Connect to the RS-232 console port .....	37
Login .....	38
Changing the WAN IP address .....	38
2. Connecting the SmartNode to the network.....	39
3. Loading the configuration (optional).....	39
Bootloader.....	40
Start Bootloader .....	40
Start-up with factory configuration .....	41
Load a new application image (SmartWare) via TFTP .....	41
Load a new application image (SmartWare) via the serial link .....	43
Additional information.....	43
<b>5 Contacting Patton for assistance .....</b>	<b>44</b>
Introduction.....	45
Contact information.....	45
Warranty Service and Returned Merchandise Authorizations (RMAs).....	45
Warranty coverage .....	45
Out-of-warranty service .....	46
Returns for credit .....	46
Return for credit policy .....	46
RMA numbers .....	46
Shipping instructions .....	46
<b>A Compliance information .....</b>	<b>47</b>
Compliance.....	48
EMC compliance: .....	48
Safety compliance: .....	48
CE Declaration of Conformity.....	48
Authorized European Representative.....	48
<b>B Specifications .....</b>	<b>49</b>

Voice connectivity - FXS .....	50
Ethernet interface .....	50
Console port.....	50
FXS ports .....	50
PPP and Frame-Relay support .....	50
Voice processing (signaling dependent) .....	50
Fax and modem support.....	51
Voice signaling .....	51
Voice routing-session router .....	52
IP services.....	52
Management .....	52
Operating environment .....	52
Temperature .....	52
Humidity .....	52
Altitude .....	53
System.....	53
Dimensions .....	53
Weight and power dissipation .....	53
Power supply.....	53
Universal AC version .....	53
DC version .....	53
Identification of the SmartNode devices via SNMP.....	54
<b>C Port pin-outs .....</b>	<b>55</b>
Introduction.....	56
Console port.....	56
Ethernet 10Base-T and 100Base-T port .....	56
FXS ports .....	57
<b>D Factory Configuration .....</b>	<b>61</b>
Introduction.....	62
<b>E End user license agreement .....</b>	<b>63</b>
End User License Agreement.....	64
1. Definitions .....	64
2. Title .....	64
3. Term .....	64
4. Grant of License .....	64
5. Warranty .....	64
6. Termination .....	65
7. Other licenses .....	65
<b>F Installation checklist .....</b>	<b>66</b>
Introduction.....	67
<b>G Accessories .....</b>	<b>68</b>
Introduction.....	69

## List of Figures

1	Model SN4432 IpChannel Bank	15
2	Model SN4432 IpChannel Bank front panel LEDs.	17
3	SmartNode 4400 rear panels	18
4	Enterprise FXS concentration and extension over IP and T1/E1	21
5	Bulk analog line extensions application	22
6	Legacy MTU/MDU migration to VoIP-based networks application	22
7	Model SN4400 Ethernet port	29
8	Straight-through RJ-45-to-RJ-45 Ethernet cable diagram	29
9	Cross-over RJ-45-to-RJ-45 Ethernet cable diagram	29
10	DB-9-to-RJ-45 cable diagram	30
11	IEC-320 connector and grounding stud locations	31
12	Grounding stud and power cable retainer clip	32
13	DC connector, -DC and +DC input view	33
14	Connecting the SmartNode to your laptop PC	35
15	Connecting the SmartNode to the network	35
16	Loading the configuration	36
17	Connecting to the RS-232 Console port	37
18	Connecting the SmartNode to the network	39
19	EIA-561 (RJ-45 8-pin) port	56
20	Model SN4400 Ethernet port	56

## List of Tables

1	General conventions .....	13
2	Front panel LEDs .....	17
3	Port descriptions .....	18
4	Installation checklist .....	25
5	Sample site log entries .....	25
6	IP addresses/subnets for SN4400 .....	26
7	Factory default IP address and network mask configuration .....	36
8	SmartNode weight and maximum power specifications .....	53
9	SmartNode Models and their Unique sysObjectID .....	54
10	Band marked color-codes for the 64-pin RJ-21X connector .....	57
11	Band marked color-codes for the 50-pin RJ-21X connector .....	59
12	Installation checklist .....	67
13	Accessory cables .....	69

# About this guide

---

This guide describes the SmartNode 4400 Series IpChannel Bank hardware, installation and basic configuration. For detailed software configuration information refer to the *SmartWare Software Configuration Guide* and the available Configuration Notes.

## Audience

---

This guide is intended for the following users:

- Operators
- Installers
- Maintenance technicians

## Structure

---

This guide contains the following chapters and appendices:

- Chapter 1, “[General information](#)” on page 14 provides information about router features and capabilities
- Chapter 2, “[Applications overview](#)” on page 20 contains an overview describing router operation and applications
- Chapter 3, “[Hardware installation](#)” on page 23 provides quick start hardware installation procedures
- Chapter 4, “[Getting started with the SmartNode 4400 Series](#)” on page 34 describes getting started with the SmartNode IpChannel Bank
- Chapter 5, “[Contacting Patton for assistance](#)” on page 44 contains information on contacting Patton technical support for assistance
- Appendix A, “[Compliance information](#)” on page 47 contains compliance information for the SmartNode
- Appendix B, “[Specifications](#)” on page 49 contains for the specifications for the IpChannel Bank
- Appendix C, “[Port pin-outs](#)” on page 55 provides cable pinouts for the various interface ports
- Appendix D, “[Factory Configuration](#)” on page 61 lists the factory configuration settings for the SmartNode 4400 Series devices
- Appendix E, “[End user license agreement](#)” on page 63 provides detailed information on the EULA
- Appendix F, “[Installation checklist](#)” on page 66 lists the tasks for installing the SmartNode 4400 IP Channel Bank

For best results, read the contents of this guide before you install the IpChannel Bank.

## Precautions

Notes, cautions, and warnings, which have the following meanings, are used throughout this guide to help you become aware of potential problems. **Warnings** are intended to prevent safety hazards that could result in personal injury. **Cautions** are intended to prevent situations that could result in property damage or impaired functioning.

**Note** A note presents additional information or interesting sidelights.



IMPORTANT

The alert symbol and IMPORTANT heading calls attention to important information.



CAUTION

The alert symbol and CAUTION heading indicate a potential hazard. Strictly follow the instructions to avoid property damage.



CAUTION

The shock hazard symbol and CAUTION heading indicate a potential electric shock hazard. Strictly follow the instructions to avoid property damage caused by electric shock.



WARNING

The alert symbol and WARNING heading indicate a potential safety hazard. Strictly follow the warning instructions to avoid personal injury.



WARNING

The shock hazard symbol and WARNING heading indicate a potential electric shock hazard. Strictly follow the warning instructions to avoid injury caused by electric shock.

## Safety when working with electricity



- Do not open the device when the power cord is connected. For systems without a power switch and without an external power adapter, line voltages are present within the device when the power cord is connected.
- For devices with an external power adapter, the power adapter shall be a listed *Limited Power Source*. The mains outlet that is utilized to power the device shall be within 10 feet (3 meters) of the device, shall be easily accessible, and protected by a circuit breaker in compliance with local regulatory requirements.
- For AC powered devices, ensure that the power cable used meets all applicable standards for the country in which it is to be installed.
- For AC powered devices which have 3 conductor power plugs (L1, L2 & GND or Hot, Neutral & Safety/Protective Ground), the wall outlet (or socket) must have an earth ground.
- For DC powered devices, ensure that the interconnecting cables are rated for proper voltage, current, anticipated temperature, flammability, and mechanical serviceability.
- WAN, LAN & PSTN ports (connections) may have hazardous voltages present regardless of whether the device is powered ON or OFF. PSTN relates to interfaces such as telephone lines, FXS, FXO, DSL, xDSL, T1, E1, ISDN, Voice, etc. These are known as "hazardous network voltages" and to avoid electric shock use caution when working near these ports. When disconnecting cables for these ports, detach the far end connection first.
- Do not work on the device or connect or disconnect cables during periods of lightning activity



When connecting to a TNV circuit, the unit **MUST BE CONNECTED TO GROUND** via the external ground stud at the rear of the unit.



This device contains no user serviceable parts. This device can only be repaired by qualified service personnel.



In accordance with the requirements of council directive 2002/96/EC on Waste of Electrical and Electronic Equipment (WEEE), ensure that at end-of-life you separate this product from other waste and scrap and deliver to the WEEE collection system in your country for recycling.

### **Preventing Electrostatic Discharge Damage**

When starting to install interface cards place the interface card on its shielded plastic bag if you lay it on your bench.

Electrostatic Discharge (ESD) can damage equipment and impair electrical circuitry. It occurs when electronic printed circuit cards are improperly handled and can result in complete or intermittent failures.



Always follow ESD prevention procedures when removing and replacing cards.

Wear an ESD-preventive wrist strap, ensuring that it makes good skin contact. Connect the clip to an unpainted surface of the chassis frame to safely channel unwanted ESD voltages to ground.

To properly guard against ESD damage and shocks, the wrist strap and cord must operate effectively. If no wrist strap is available, ground yourself by touching the metal part of the chassis.

### **General observations**

- Clean the case with a soft slightly moist anti-static cloth
- Place the unit on a flat surface and ensure free air circulation
- Avoid exposing the unit to direct sunlight and other heat sources
- Protect the unit from moisture, vapors, and corrosive liquids

## Typographical conventions used in this document

This section describes the typographical conventions and terms used in this guide.

### General conventions

The procedures described in this manual use the following text conventions:

Table 1. General conventions

Convention	Meaning
Garamond blue type	Indicates a cross-reference hyperlink that points to a figure, graphic, table, or section heading. Clicking on the hyperlink jumps you to the reference. When you have finished reviewing the reference, click on the <b>Go to Previous View</b> button  in the Adobe® Acrobat® Reader toolbar to return to your starting point.
Futura bold type	Commands and keywords are in <b>boldface</b> font.
Futura bold-italic type	Parts of commands, which are related to elements already named by the user, are in <b>boldface italic</b> font.
<i>Italicized Futura type</i>	Variables for which you supply values are in <i>italic</i> font
Futura type	Indicates the names of fields or windows.
Garamond bold type	Indicates the names of command buttons that execute an action.
< >	Angle brackets indicate function and keyboard keys, such as <SHIFT>, <CTRL>, <C>, and so on.
[ ]	Elements in square brackets are optional.
{ a   b   c }	Alternative but required keywords are grouped in braces ( { } ) and are separated by vertical bars (   )
blue screen	Information you enter is in <b>blue screen</b> font.
screen	Terminal sessions and information the system displays are in <b>screen</b> font.
node	The leading IP address or nodename of a SmartNode is substituted with <b>node</b> in <b>boldface italic</b> font.
SN	The leading <b>SN</b> on a command line represents the nodename of the SmartNode
#	An hash sign at the beginning of a line indicates a comment line.

# Chapter 1 **General information**

## **Chapter contents**

- SmartNode 4400 Series overview.....15
- SmartNode 4400 Series detailed description.....16
  - SmartNode 4400 Series front panel .....17
  - SmartNode 4400 Series rear panels .....18
  - Reset button behavior .....19

## SmartNode 4400 Series overview

The IpChannel Bank 4400 Series are Analog Access Routers that support 12 to 32 VoIP calls. Filling the gap between small media gateways and T1/E1 gateway equipment, the SN4400 Series IpChannel Bank fits your needs cost effectively—so you won't have to “stack” multiple smaller units or buy an over-designed product.



Figure 1. Model SN4432 IpChannel Bank

The following base models are available:

- IpChannel Bank 4412 (12 VoIP calls)
- IpChannel Bank 4416 (16 VoIP calls)
- IpChannel Bank 4424 (24 VoIP calls)
- IpChannel Bank 4432 (32 VoIP calls)

Refer to appendix B, “Specifications” on page 49 for a complete feature description of the SN4400 Series.

The SmartNode 4400 Series comes equipped with two 10/100Base-T Ethernet ports and from 12 to 32 FXS ports. This provides voice-over-IP (VoIP) and Internet telephony integrated with routed serial-WAN access. The SN4400 IpChannel Bank supports Frame-Relay and PPP networking with VPN and firewall functions and provides extensive quality of service (QoS) features for best-possible voice quality over any broadband IP network.

The SmartNode IpChannel Bank performs the following major functions:

- Voice over IP and local switching via a combination of 12, 16, 24, or 32 analog phone ports (FXS).
- Standards-compliant conversion between analog voice and digital VoIP in accordance with SIP and H.323 protocols.
- Internet access and IP Routing with IP QoS support for mixed voice and data traffic.
- Routed LAN-to-WAN connectivity between two 10/100 Ethernet LAN ports

## SmartNode 4400 Series detailed description

---

The SmartNode 4400 Series IpChannel Bank provides VoIP calling from 12 to 32 analog phone lines. Integrated within the IpChannel Bank are 2 Ethernet ports, one for LAN, the other for WAN connectivity. The front panel contains LED indicators for system status-at-a-glance, and the rear panel provides connectivity for the FXS analog ports, the ENET ports, a WAN port, and an RS-232 control port.

Each model in the SN4400 series comes equipped with two 10/100Base-T Ethernet ports. Ethernet port *ETH0/1* is commonly used for the LAN connection. *ETH0/0* can be used for WAN access or as a second LAN connection. The following base model numbers are available:

- SN4412/JS/UI (12 FXS ports, UI power supply)
- SN4416/JS/UI (16 FXS ports, UI power supply)
- SN4424/JS/UI (24 FXS ports, UI power supply)
- SN4432/JS/UI (32 FXS ports, UI power supply)
- SN4412/JS/48 (12 FXS ports, 48V DC power supply)
- SN4416/JS/48 (16 FXS ports, 48V DC power supply)
- SN4424/JS/48 (24 FXS ports, 48V DC power supply)
- SN4432/JS/48 (32 FXS ports, 48V DC power supply)

**Note** The model-code suffixes indicate the following features according to the following conventions:

- *JS* indicates FXS ports are present
- *UI* indicates universal input (UI) power supply
- *48* indicates internal 48V DC power supply

### SmartNode 4400 Series front panel

The front panel LEDs display the status of the power, system, VOIP channels, Ethernet ports, and call load. The front panel includes the following LEDs. Figure 2 shows the front panel LED indicators and table 2 provides a description of the LED indicators' behavior.

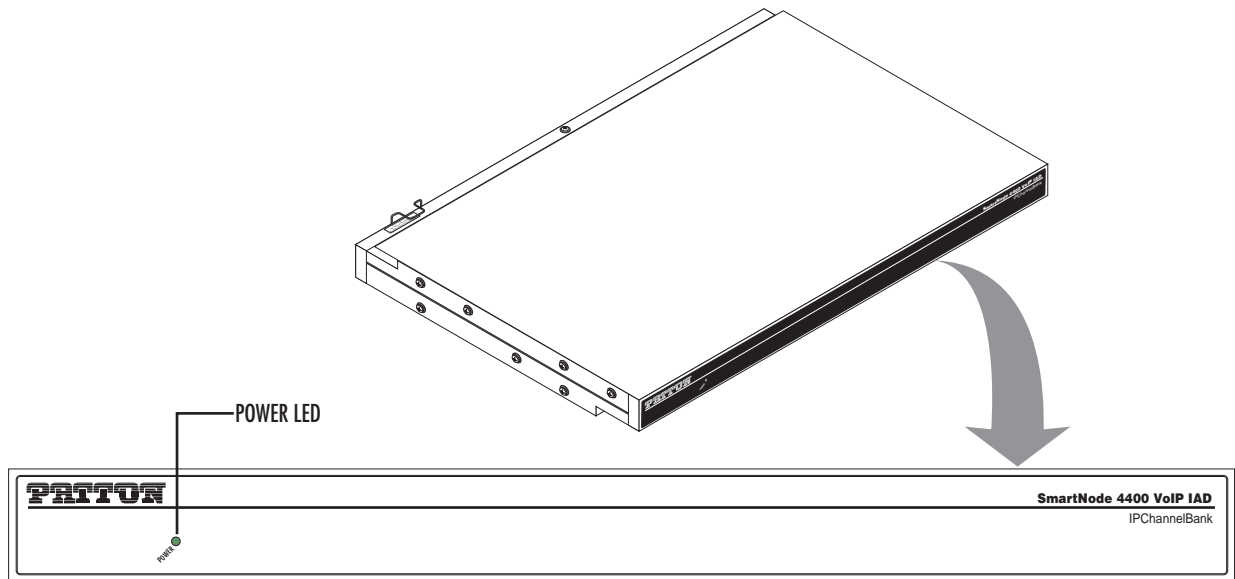

Figure 2. Model SN4432 IpChannel Bank front panel LEDs.

Table 2. Front panel LEDs

LED	LED Condition	Description
Power	Solid Green	Power is applied

### SmartNode 4400 Series rear panels

The SmartNode 4400 rear panel ports are shown in [figure 3](#) and described in [table 3](#) on page 18.

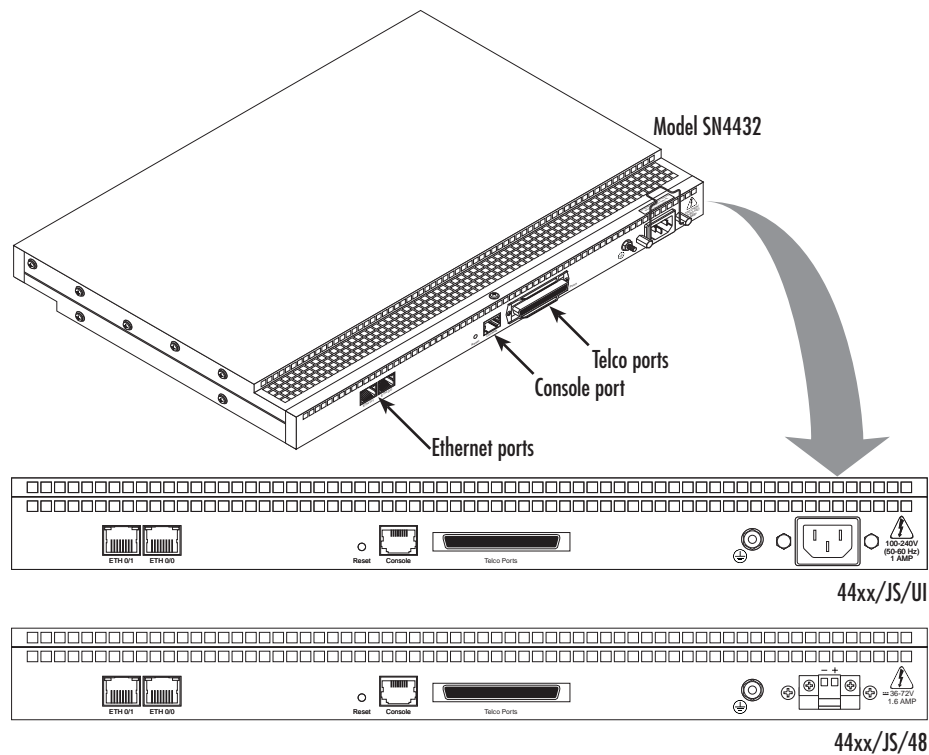

Figure 3. SmartNode 4400 rear panels

Table 3. Port descriptions

Port	Description
<b>ETH 0/0</b> (WAN Ethernet 0/0 port)	10/100Base-Tx full-/half-duplex, RJ-45, auto detection and auto-MDI-X connects the unit to an Ethernet WAN device (for example, a cable modem, DSL modem, or fiber modem).
<b>ETH 0/1</b> (LAN Ethernet 0/1 port)	10/100Base-Tx full-/half-duplex, RJ-45, auto detection and fall-back, connects the unit to an Ethernet LAN.
<b>Console</b> (RS-232 control port)	Used for service and maintenance, the Console port, an RS-232 RJ-45 connector with EIA-561 pinout, connects the router to a serial terminal such as a PC or ASCII terminal (also called a dumb terminal). Asynchronous default data rate 9600 bps, hardware DSR and DTR signals for external modems are wired directly together internally
<b>FXS Ports</b> (4400/JS models)	For connection of up to 32 analog FXS devices (selectable for 12, 16, 24, or 32). Either a 50-pin or 64-pin RJ21X connector that connects the router to an analog terminal (a telephone, for example) FXO port. EuroPOTS support (ETSI EG201 188).

### *Reset button behavior*

For those SmartNode devices that have a *Reset* button on the rear panel, its behavior is as follows:

- To restart the unit with the current startup configuration—Press for less than 1 second and release the *Reset* button. The SmartNode will restart with the current startup configuration.
- To restart the unit with factory default configuration—Press the *Reset* button for 5 seconds until the Power LED starts blinking. The unit will restart with factory default configuration.
- To restart the unit in bootloader mode (to be used only by trained SmartNode technicians)—Start with the unit powered off. Press and hold the *Reset* button while applying power to the unit. Release the *Reset* button when the *Power* LED starts blinking so the unit will enter bootloader mode.

## Chapter 2 **Applications overview**

### **Chapter contents**

Introduction.....	21
SmartNode 4400 Series applications.....	21
Enterprise FXS concentration and extension over IP and T1/E1 .....	21
Bulk analog line extensions .....	22
Legacy MTU/MDU migration to VoIP based networks .....	22

## Introduction

Patton's SmartNode 4400 Series deliver the features you need for advanced multiservice voice and data networking. SmartNode 4400 Series combine high-quality voice-over-IP with powerful quality of service routing features to deliver seamlessly integrated VoIP and data access over leased lines. This chapter describes typical applications for which the SmartNode 4400 Series series is uniquely suited.

**Note** Detailed configuration information for the applications can be found on the CD-ROM that was included with your SmartNode device or online from the Patton webserver.

## SmartNode 4400 Series applications

SmartNode 4400 Series devices have dual 10/100Base-T Ethernet ports. The two Ethernet ports provide full featured IP routing plus Ethernet and IP layer QoS services. Voice prioritization and traffic management avoid network congestion and provide optimal voice quality. The following sections show two typical converged voice-and-data applications.

Like all members of the SmartNode family of VoIP solutions, the SmartNode 4400 Series supports all industry-standard VoIP signaling protocols, including SIP, H.323, T.38 fax-relay, plus fax- and modem-bypass. The SmartNode 4400 is interoperable with leading softswitches and VoIP servers

### Enterprise FXS concentration and extension over IP and T1/E1

The SN4400 Series IpChannel Bank can be used with a T1/E1 gateway to extend a T1 or E1 line over IP and split it into FXS ports—providing operators and enterprise network administrators with a simple and cost-effective option to provide a large number of FXS ports in a remote location (see [figure 4](#)).

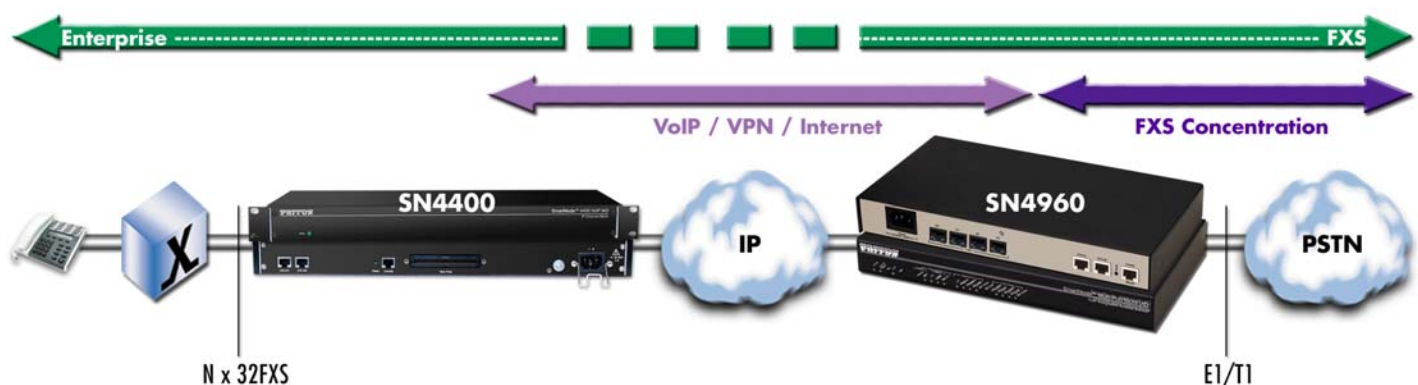

Figure 4. Enterprise FXS concentration and extension over IP and T1/E1

### Bulk analog line extensions

The SN4400 FXS models used in combination enable enterprises to extend up to 32 analog phone lines over any IP link – be it the public Internet, a leased line or a WiMax link. 600kBit/s bandwidth are enough for 32 simultaneous voice or fax conversations, using G.723 compressed voice transmission.

Advanced quality of service (QoS) features ensure optimal bandwidth usage and voice quality, even on small bandwidth links and with simultaneous transport of data or VPN traffic between the SmartNodes.



Figure 5. Bulk analog line extensions application

### Legacy MTU/MDU migration to VoIP based networks

The SN4400 IPChannel Bank offers an ideal way for Service Providers (SP) to migrate their existing networks to standards based VoIP networks. By using the Telco Connector port, the existing closet wiring in the MTU/MDU can be utilized and the customer's analog devices can now be connected to feature rich VOIP based networks. This protects the investments that have been made in Analog equipment and wiring by various MTU/MDU facilities and leverages it further by connecting these facilities to the Service Provider's VoIP based networks.

Above all, it allows simple and transparent migration process for enterprise and residential customers in the MTU/MDU facilities.



Figure 6. Legacy MTU/MDU migration to VoIP-based networks application

## Chapter 3 **Hardware installation**

### **Chapter contents**

Introduction .....	24
Planning the installation .....	24
Installation checklist .....	25
Site log .....	25
Network information .....	26
Network diagram .....	26
IP related information .....	26
Configuration tools .....	26
AC Power Mains .....	26
Location and mounting requirements .....	27
Installing the IpChannel Bank .....	27
Unpacking the Model SN4400 series IpChannel Bank .....	27
IpChannel Bank chassis installation .....	27
Connecting cables .....	28
Connecting the FXS ports .....	28
Connecting the Ethernet ports .....	28
Connecting the 10/100Base-T Ethernet ports to an Ethernet switch or hub.....	29
Connecting a 10/100Base-T Ethernet port to an Ethernet-capable workstation .....	29
Connecting the EIA-561 RS-232 configuration port (DCE configured) .....	30
Connecting power .....	30
Grounding the Model SN4400—AC and DC units .....	30
Installing the power cables—AC units .....	31
Installing the power cables—DC units .....	32

## Introduction

---

This chapter contains information for planning the installation of the SmartNode 4400 IpChannel Bank with the following installation procedures:

- Section “[Unpacking the Model SN4400 series IpChannel Bank](#)” on page 27 lists the contents of the shipping box
- Section “[IpChannel Bank chassis installation](#)” on page 27 describes installing the IpChannel Bank on a flat surface or in a 19-inch rack
- Section “[Connecting cables](#)” on page 28 describes installing the power and port cables
- Section “[Connecting power](#)” on page 30 describes how to verify that the IpChannel Bank is ready for configuration

## Planning the installation

---

Before beginning the actual installation, we strongly recommend that you gather all the information you will need to install and set up the device. See [table 4](#) for an example of installment checklist that may be necessary for a smoother installation. Completing the pre-installation checks enables you to install and set up your IpChannel Bank within an existing network infrastructure with confidence.

Before installing the IpChannel Bank device, the following tasks should be completed:

- **Prepare an installation checklist** using the list provided in section “[Installation checklist](#)” on page 25
- **Initiate and maintain a site log** using the information in section “[Site log](#)” on page 25 as a guide
- **Create a network diagram** (see section “[Network information](#)” on page 26)
- **Gather IP related information** (see section “[IP related information](#)” on page 26 for more information)
- **Install the hardware and software needed to configure the SmartNode.** (See section “[Configuration tools](#)” on page 26)
- **Verify power source reliability** (see section “[AC Power Mains](#)” on page 26).

When you finish preparing for your VoIP installation, go to section “[Installing the IpChannel Bank](#)” on page 27 to install the device.

### Installation checklist

The installation checklist (see [table 4](#)) lists the tasks for installing a SmartNode 4400 Series IpChannel Bank. Make a copy of this checklist and mark the entries as you complete each task. For each SmartNode 4400, include a copy of the completed checklist in your site log. This installation checklist is also available in appendix F, “[Installation checklist](#)” on page 66.

Table 4. Installation checklist

Task	Verified by	Date
Network information available & recorded in site log		
Environmental specifications verified		
Site power voltages verified		
Installation site pre-power check completed		
Required tools available		
Additional equipment available		
All printed documents available		
SmartWare release & build number verified		
Rack, desktop, or wall mounting of chassis completed		
Initial electrical connections established		
ASCII terminal attached to console port		
Cable length limits verified		
Initial configuration performed		
Initial operation verified		

### Site log

Patton recommends that you maintain a site log to record all actions relevant to the system, if you do not already keep such a log. Site log entries should include information such as listed in [table 5](#).

Table 5. Sample site log entries

Entry	Description
Installation	Make a copy of the installation checklist and insert it into the site log. (See appendix F, “ <a href="#">Installation checklist</a> ” on page 66.)
Upgrades & maintenance	Use the site log to record ongoing maintenance and history
Configuration changes	Record all changes and the reasons for them
Maintenance	Schedules, requirements and procedures performed
Comments	Notes and problems
Software	Changes and updates to SmartWare software

## Network information

When planning your installation there are certain critical considerations for the network connections. The following sections describe such considerations for several types of network interfaces.

### Network diagram

Draw a network overview diagram that displays all neighboring IP nodes, connected elements and telephony components.

### IP related information

Before you can set up the basic IP connectivity for your SmartNode 4400 series you should have the following information (see [table 6](#)):

- IP addresses used for Ethernet LAN and WAN ports
- Subnet mask used for Ethernet LAN and WAN ports
- IP addresses of central H.323 Gatekeeper (if used)
- IP addresses of central PSTN Gateway for H.323 based calls
- IP addresses of central TFTP Server used for configuration upload and download

Table 6. IP addresses/subnets for SN4400

Port/Device	IP Address	IP Subnet
Ethernet LAN (ETH 0/1)		
Ethernet WAN (ETH 0/0)		
H.323 Gatekeeper (if used)		
IP address of central PSTN gateway (H.323-based calls)		
IP address of central TFTP server for configuration upload/downloads		

## Configuration tools

You will need a PC (or equivalent) with a VT-100 emulation program (e.g. HyperTerminal) to configure the software on your SmartNode 4400.

## AC Power Mains

If you suspect that your AC power is not reliable, for example if room lights flicker often or there is machinery with large motors nearby, have a qualified professional test the power. Install a power conditioner if necessary. Refer to “[Connecting power](#)” on page 30.



**The mains outlet that is utilized to power the equipment must be within 1 foot (3 meters) of the device and shall be easily accessible.**

**Note** When setting up your SmartNode you must consider cable-length limitations and potential electromagnetic interference (EMI) as defined by the applicable local and international regulations. Ensure that your site is properly prepared before beginning installation.

### Location and mounting requirements

The SmartNode 4400 is intended to be placed on a desktop or similar sturdy, flat surface that offers easy access to the cables or be installed in a standard 19-inch rack chassis. Allow sufficient space at the rear of the chassis for cable connections. Additionally, you should consider the need to access the unit for future upgrades and maintenance.

**Airflow requirements** – To ensure proper airflow through the SmartNode, follow these recommendations when you are installing your unit:

- If placed on a desktop, leave 7.62 cm (3 inches) of minimum clearance on both the left and right sides of the unit.
- If mounted in a rack, leave a one-rack unit (1U) of minimum clearance above and below the unit for proper airflow.

**Note** The SmartNode 4900 model is available for racks that require tighter spacing requirements than what the SN4400 model allows for minimum clearance.

This completes the planning phase for installation. The next section begins the installation procedures.

## Installing the IpChannel Bank

---

### Unpacking the Model SN4400 series IpChannel Bank

Inspect the shipping carton for external damage. Note any damage before removing the container contents. Report any equipment damage to the shipping carrier immediately for claim purposes. Save all packing material in case you need to return an item to the factory for servicing.

The IpChannel Bank comes with the following items:

- *Model SN4400 Series IpChannel Bank Quick Start Guide*
- Model SN4400 Series IpChannel Bank
- An RJ-45-to-RJ-45 cable for use with the console and Ethernet ports
- A DB-9-to-RJ-45 (EIA-561) adapter for connecting a PC's serial port to the IpChannel Bank console port
- Rack mounting kit with rack ears and mounting hardware
- CD-ROM containing product literature, the *Model SN4400 IpChannel Bank Getting Started Guide* and the *Smartware Software Configuration Guide*

**Note** Power cables are shipped separately from the Model SN4400 Series IpChannel Bank

**Note** Contact Patton Electronics for the proper RJ-21X cable for the FSX ports

### IpChannel Bank chassis installation

Do the following:

1. If you have not done so already, remove the IpChannel Bank from its shipping container.

2. If you are installing the IpChannel Bank in a 19-inch rack, go to step 4. Otherwise, place the IpChannel Bank at the desired location.
3. Go to section “[Connecting cables](#)” on page 28
4. Install the rack mounting ears onto the IpChannel Bank using the mounting hardware provided.
5. Place the IpChannel Bank at the desired position in the rack.
6. Secure the IpChannel Bank in position with the mounting screws.
7. Go to section “[Connecting cables](#)” on page 28

### Connecting cables

This section describes installing the interface, power, and ground cables in the following order:



The Interconnecting cables must be acceptable for external use and must be rated for the proper application with respect to voltage, current, anticipated temperature, flammability, and mechanical serviceability.

1. Installing the RJ-11 voice port (FXS) cable or cables (see section “[Connecting the FXS ports](#)” on page 28)
2. Installing the 10/100 Ethernet port cable (see section “[Connecting the Ethernet ports](#)” on page 28)
3. Installing the RS-232 console cable (see section “[Connecting the EIA-561 RS-232 configuration port \(DCE configured\)](#)” on page 30)
4. Installing the power input (see section “[Connecting power](#)” on page 30)



**Do not work on the system or connect or disconnect cables during periods of lightning activity.**

#### Connecting the FXS ports

The remote FXO devices are connected to the IpChannel Bank via the RJ-21X cable. Consult [Appendix C on page 55](#) in order to connect the FXO devices to the selected FXS port on the IpChannel Bank.

1. Connect the RJ-21X connector of the cable into the 64-pin or 50-pin RJ-21X receptacle on the IpChannel Bank. The pin count will depend on the IpChannel Bank that you ordered.
2. The other end of the cable has 25 non-terminated twisted-pairs for connection to punch-down blocks. Select the twisted-pairs which will be used for
3. Select and attach the appropriate twisted-pair from each FXO device on punch-down blocks for connection to the chosen port on the IpChannel Bank.

#### Connecting the Ethernet ports

The IpChannel Bank has dual 10/100 Ethernet interfaces. One is for the WAN connection. The other is for connecting to your Ethernet LAN. The Ethernet ports will auto-sense the correct speed of the local LAN and

automatically negotiate to half- or full-duplex operation. This section describes connecting the IpChannel Bank to the Ethernet LAN via an Ethernet hub or switch.

**Connecting the 10/100Base-T Ethernet ports to an Ethernet switch or hub.** The 10/100Base-T Ethernet port is designed to connect to an Ethernet switch or hub with a straight-through or cross-over Ethernet cable. The Ethernet RJ-45 pin and signal definitions for the SN4400 or for a NIC card in a workstation/PC are shown in figure 7. Connect a CAT-5 cable (one wired as shown in figure 8 or figure 9) between the SN4400 and the hub/switch.

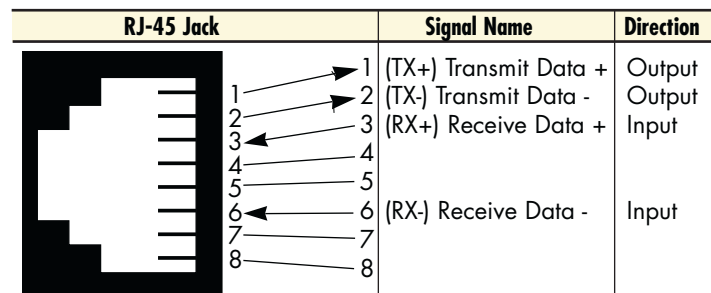

Figure 7. Model SN4400 Ethernet port

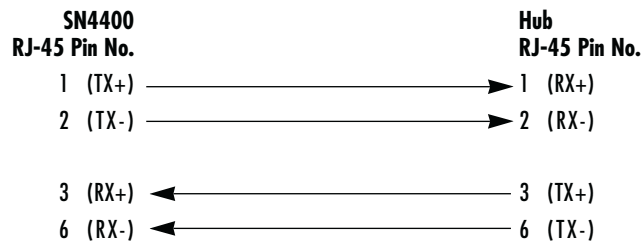

Figure 8. Straight-through RJ-45-to-RJ-45 Ethernet cable diagram

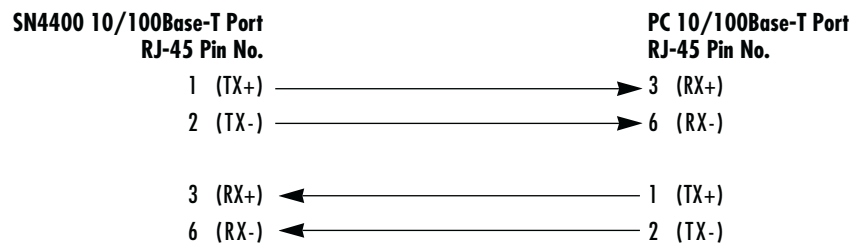

Figure 9. Cross-over RJ-45-to-RJ-45 Ethernet cable diagram

**Connecting a 10/100Base-T Ethernet port to an Ethernet-capable workstation.** The 10/100Base-T Ethernet ports can connect to a single Ethernet-capable workstation or PC by means of any Ethernet cable.

**Connecting the EIA-561 RS-232 configuration port (DCE configured)**

Install the supplied RJ-45-to-RJ-45 cable with the DB9-RJ45 adapter between the SN4400 IpChannel Bank RS-232 console port (figure 10) and an open serial port on your computer. If you need to assemble your own cable, refer to the pinout diagram in figure 10.

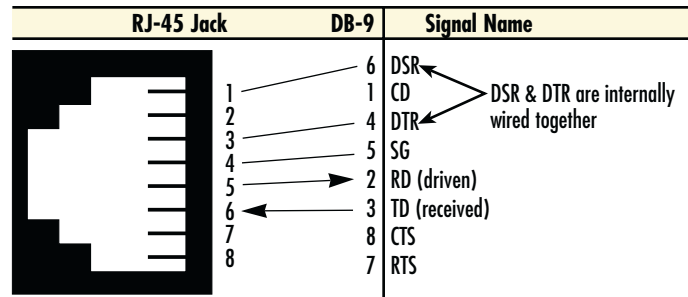

Figure 10. DB-9-to-RJ-45 cable diagram

**Connecting power**

In connecting to the power source, it is important to establish a good grounding connection first, then the power connection. This section explains:

- Making the ground connection for either AC or DC units (see section “Grounding the Model SN4400—AC and DC units”)
- Connecting to an AC power source (see “Installing the power cables—AC units” on page 31)
- Connecting to a DC power source (see “Installing the power cables—DC units” on page 32)

**Grounding the Model SN4400—AC and DC units**

Do the following:

1. Assemble a ground wire using #10 AWG wire with green-colored insulation and two ring terminals. Make the wire long enough to reach one of the following earth ground sources:
  - The building ground rod (generally located at the site’s main service entrance)
  - A sprinkler system pipe
  - A cold-water pipe
  - Building structural steel

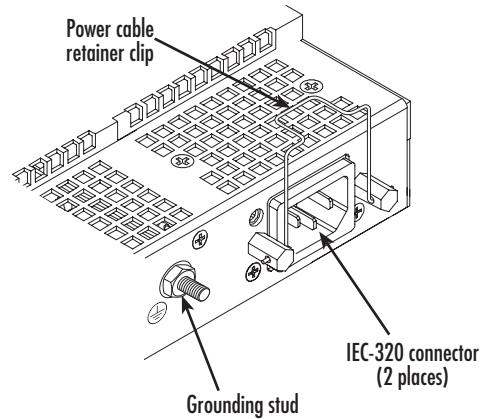

Figure 11. IEC-320 connector and grounding stud locations

2. Install the grounding wire between the grounding stud (see [figure 11](#)) and the grounding source.



**Mains Voltage: Do not open the case the when the power cord is attached. Line voltages are present within the power supply when the power cords are connected. The mains outlet that is utilized to power the device shall be within 10 feet (3 meters) of the device, shall be easily accessible, and protected by a circuit breaker.**



**The Model SN4400 is not shipped with power cables. For AC powered units, ensure that the power cable used meets all applicable standards for the country in which it is to be installed, and that it is connected to a wall outlet which has earth ground.**



**The router power supply automatically adjusts to accept an input voltage from 100 to 240 VAC(50/60 Hz).**

#### *Installing the power cables—AC units*

This section describes installing the power cables into the IEC-320 connectors on the IpChannel Bank. Do not connect the remaining end of the power cables to the power outlet at this time. Do the following:

1. Install the power cable into an IEC-320 connector (see [figure 11](#) on page 31). The AC mains socket outlet shall be within 1 foot (3 meters) of the equipment and shall be easily accessible.

2. Rotate the power cable retainer clip so it secures the power cable plug in the IEC-320 connector as shown in [figure 12](#).

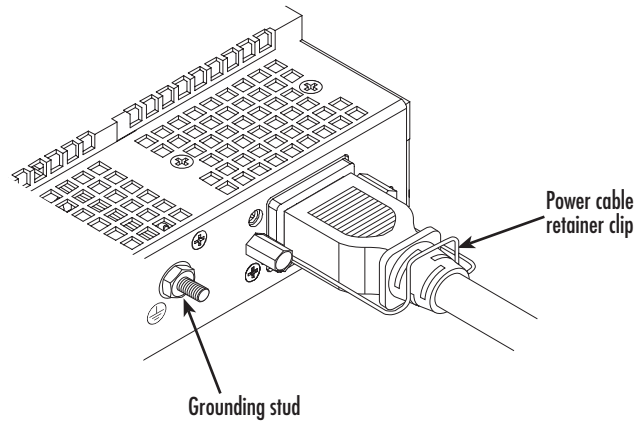

Figure 12. Grounding stud and power cable retainer clip

3. Repeat steps 1 and 2 to install the remaining power cable.
4. Verify that the AC power cord included with your IpChannel Bank is compatible with local standards. If it is not, refer to chapter 5, “[Contacting Patton for assistance](#)” on page 44 to find out how to replace it with compatible power cord.
5. Connect the male end of the power cord to an appropriate power outlet.
6. Verify that the green *POWER* LED is lit.

Hardware installation is complete. Refer to chapter 4, “[Getting started with the SmartNode 4400 Series](#)” on page 34.

#### *Installing the power cables—DC units*



**Mains Voltage: Do not open the case the when the power cord is attached. Line voltages are present within the power supply when the power cords are connected. The mains outlet that is utilized to power the devise shall be within 10 feet (3 meters) of the device, shall be easily accessible, and protected by a circuit breaker.**

**Do not connect the power cables to the DC power source at this time.** For the DC power source, the IpChannel Bank is equipped with a two-position, screw-down terminal block (see [figure 13](#)).

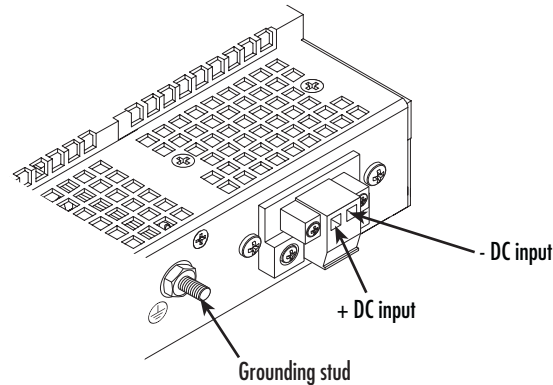

Figure 13. DC connector, -DC and +DC input view

1. Connect the earth ground of the DC source to the grounding stud on the DACS as described in the previous section entitled “Grounding the Model SN4400—AC and DC units.”
2. Strip back the insulation on each of the wires approximately 1/4-inch.
3. Insert the stripped end of the positive lead into the *+DC input* of the terminal block. Tighten the screw until the power lead is firmly fastened. Repeat the procedure for the negative lead, using the *-DC input* of the terminal block. Make sure that all strands of the wire are captured and that there are no exposed wires.
4. Repeat steps 1 through 3 to install the remaining DC power connection.



CAUTION

An approved power supply that incorporates a disconnect device must be used and positioned within easy reach of the operator’s position.

5. Connect the equipment to a 36–72 VDC, 2.5A supply source that is electrically isolated from the AC source. The 36–72 VDC source is to be reliably connected to earth ground.
6. Verify that the green *POWER* LED is lit.

Hardware installation is complete. Refer to chapter 4, “[Getting started with the SmartNode 4400 Series](#)” on page 34.

# Chapter 4 **Getting started with the SmartNode 4400 Series**

## **Chapter contents**

Introduction .....	35
1. Configure IP address .....	36
Factory-default IP settings .....	36
Connect to the RS-232 console port .....	37
Login .....	38
Changing the WAN IP address .....	38
2. Connecting the SmartNode to the network .....	39
3. Loading the configuration (optional) .....	39
Bootloader .....	40
Start Bootloader .....	40
Start-up with factory configuration .....	41
Load a new application image (SmartWare) via TFTP .....	41
Load a new application image (SmartWare) via the serial link .....	43
Additional information .....	43

## Introduction

This chapter leads you through the basic steps to set up a new SmartNode and to download a configuration. Setting up a new SmartNode consists of the following main steps:

**Note** If you have not already installed the SmartNode, refer to chapter 3, “Hardware installation” on page 23.

1. **Configuring the desired IP address** (see figure 14). Refer to section “2. Connecting the SmartNode to the network” on page 39 for details.

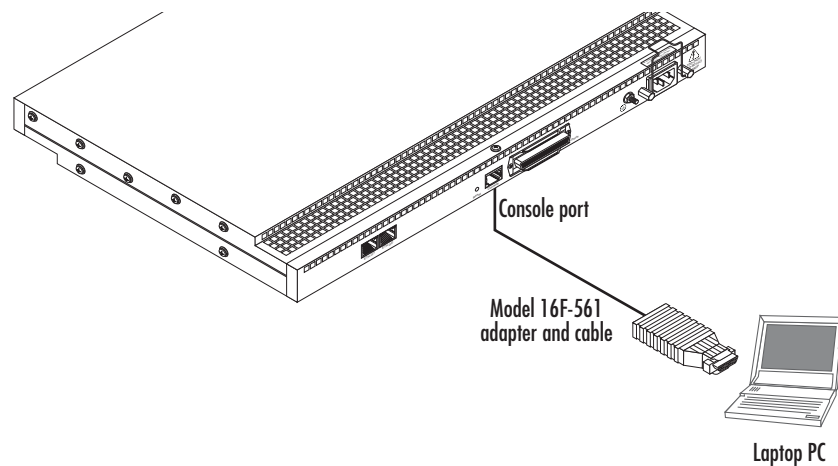

Figure 14. Connecting the SmartNode to your laptop PC

2. **Connecting the SmartNode to the network** (see figure 15). Refer to section “1. Configure IP address” on page 36 for details).

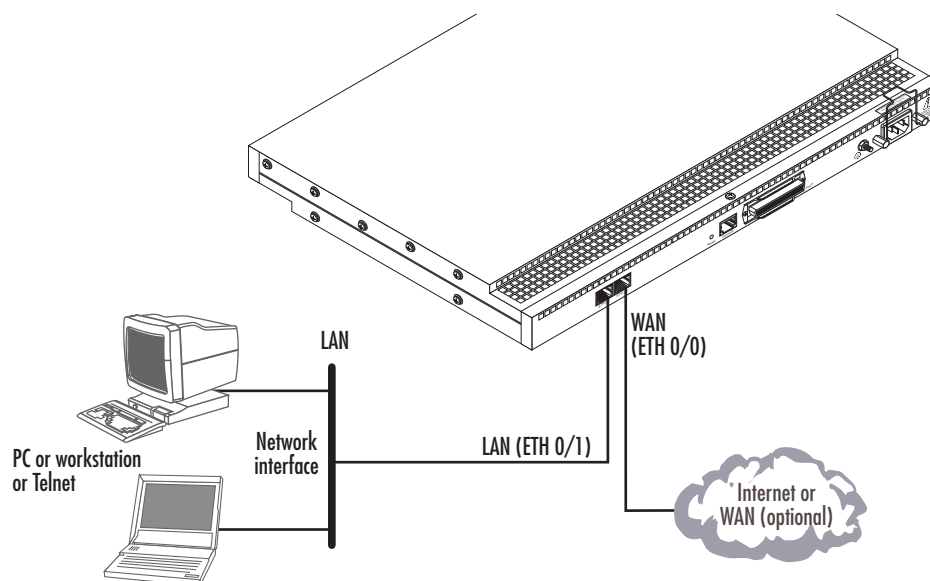

Figure 15. Connecting the SmartNode to the network

3. **Loading the configuration** (see figure 16). Refer to section “2. Connecting the SmartNode to the network” on page 39 for details.

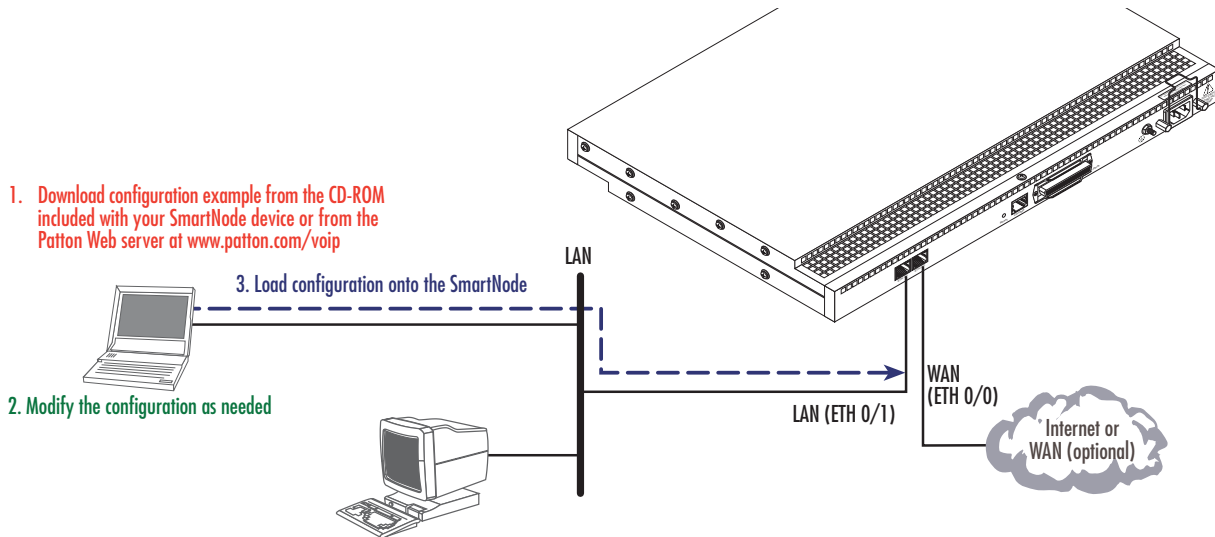

Figure 16. Loading the configuration

**Note** You can manually configure the SmartNode. You do not have to load a configuration file.

**Note** The SmartNode CD-ROM contains a collection of third party software tools (including TFTP servers and Telnet utilities) to help you configure, operate and monitor the SmartNode device.

## 1. Configure IP address

### Factory-default IP settings

Both Ethernet interfaces are activated upon power-up. The LAN interface ETH 0/1 (LAN) provides a default DHCP server. The factory default configuration for the Ethernet interface IP addresses and network masks are listed in table 7. Both Ethernet interfaces are activated upon power-up. LAN interface ETH 0/1 (LAN) provides a default DHCP server.

Table 7. Factory default IP address and network mask configuration

	IP Address	Network Mask
WAN interface Ethernet 0 (ETH 0/0)	DHCP	DHCP
LAN interface Ethernet 1 (ETH 0/1)	192.168.1.1	255.255.255.0(/24)
DHCP IP address range	192.168.1.10 - 192.168.1.19	255.255.255.0(/24)

If these addresses match with those of your network, go to section “2. Connecting the SmartNode to the network” on page 39. Otherwise, refer to the following sections to change the addresses and network masks.

**Note** The SmartNode CD-ROM contains a collection of third party software tools (including TFTP servers and Telnet utilities) to help you configure, operate and monitor the SmartNode device.

### Connect to the RS-232 console port

The RJ-45 *Console* port is wired as an EIA-561, RS-232 port. Use the included Model 16F-561 adapter and cable (see [figure 17](#)) between the SmartNode's Console port and a PC or workstation's RS-232 serial interface. Activate the terminal emulation program on the PC or workstation that supports the serial interface (e.g. HyperTerm).

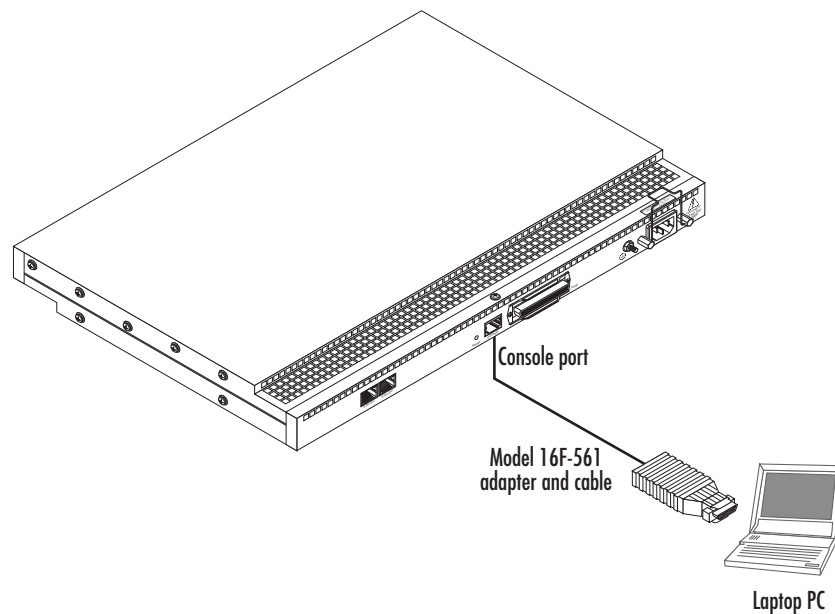

Figure 17. Connecting to the RS-232 Console port

Terminal emulation program settings:

- Asynchronous
- 9600 bps
- No parity
- 8 bit
- 1 stop bit
- No flow control

## Login

To access the SmartNode, start the Telnet application. Type the default IP address for the router into the address field: *192.168.1.1*. Accessing your SmartNode via a Telnet session displays the login screen. Type the factory default login: *administrator* and leave the password empty. Press the <Enter> key after the password prompt.

```
login:administrator
password: <Enter>
192.168.1.1>
```

After you have successfully logged in you are in the operator execution mode, indicated by > as command line prompt. With the commands enable and configure you enter the configuration mode.

```
192.168.1.1>enable
192.168.1.1#configure
192.168.1.1(cfg)#
```

## Changing the WAN IP address

Select the context IP mode to configure an IP interface.

```
192.168.1.1(cfg)#context ip router
192.168.1.1(ctx-ip)[router]#
```

Now you can set your IP address and network mask for the interface ETH 0/0 (WAN). Within this example a network 172.16.1.0/24 address is assumed. The IP address in this example is set to 172.16.1.99 (you should set this the IP address given to you by your network provider).

```
172.16.1.99(ctx-ip)[router]#interface eth0
172.16.1.99(if-ip)[eth0]#ipaddress 172.16.1.99 255.255.255.0
2002-10-29T00:09:40 : LOGINFO : Link down on interface eth0.
2002-10-29T00:09:40 : LOGINFO : Link up on interface eth0.
172.16.1.99(if-ip)[eth0]#
```

**Note** If your WAN connection's IP address is assigned via DHCP, refer to Chapter 21, "DHCP configuration" in the SmartNode Series SmartWare Software Configuration Guide for information on configuring DHCP. Copy this modified configuration to your new start-up configuration. Upon the next start-up the system will initialize itself using the modified configuration.

```
172.16.1.99(if-ip)[eth0]#copy running-config startup-config
172.16.1.99(if-ip)[eth0]#
```

The SmartNode can now be connected to your network.

## 2. Connecting the SmartNode to the network

In general, the SmartNode will connect to the network via the ETH 0/0 (WAN) port. This enables the SmartNode to offer routing services to the PC hosts on the ETH 0/1 (LAN) port. The SmartNode 4400 Series is equipped with Auto-MDI-X Ethernet ports, so you can use straight-through or crossover cables for host or hub/switch connections (see figure 17).

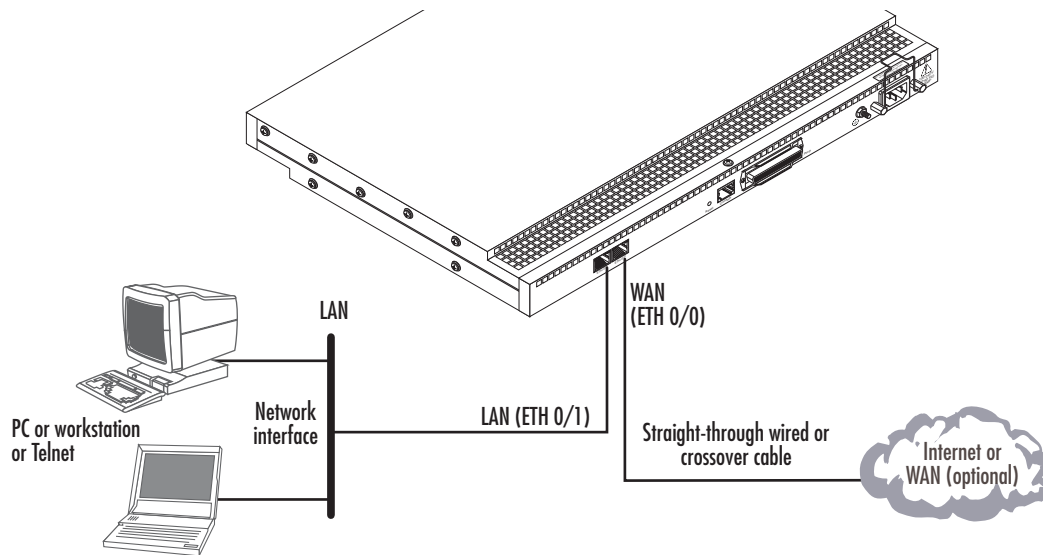

Figure 18. Connecting the SmartNode to the network

You can check the connection with the ping command from the SmartNode to another host on the network.

```
172.16.1.99(if-ip)[eth0]#ping <IP Address of the host>
```

Respectively from the host: **ping 172.16.1.99**

**Note** To ping outside your local LAN, you will need to configure the default gateway. (For information on configuring the default gateway, refer to section "Set IP addresses" in Appendix C, "Command Summary" of the SmartNode Series SmartWare Software Configuration Guide.)

## 3. Loading the configuration (optional)

Patton provides a collection of configuration templates on the CD-ROM that came with the SmartNode device—and also on the support page at [www.patton.com/voip](http://www.patton.com/voip)—one of which may be similar enough to your application that you can use it to speed up configuring the SmartNode. Simply download the configuration note that matches your application to your PC. Adapt the configuration as described in the configuration note to your network (remember to modify the IP address) and copy the modified configuration to a TFTP server. The SmartNode can now load its configuration from this server.

**Note** Patton regularly adds new configuration templates to the collection at [www.patton.com/voip](http://www.patton.com/voip), so if you do not see your application on the CD-ROM, it may have been added to the website.

**Note** If your application is unique and not covered by any of Patton's configuration templates, you can manually configure the SmartNode instead of loading a configuration file template. In that case, refer to the *SmartNode Series SmartWare Software Configuration Guide* for information on configuring the SmartNode device.

In this example we assume the TFTP server on the host with the IP address 172.16.1.11 and the configuration named *SN.cfg* in the root directory of the TFTP server.

```
172.16.1.99(if-ip)[eth0]#copy tftp://172.16.1.11/SN.cfg startup-config
Download...100%
172.16.1.99(if-ip)[eth0]#
```

After the SmartNode has been rebooted the new startup configuration will be activated.



When you issue the **reload** command, the SmartNode will ask if you want to copy the running configuration to the startup configuration. Since you just downloaded a configuration file to the startup configuration you must answer this question with **NO**. Otherwise, the downloaded configuration will be overwritten and lost!

```
172.16.1.99(if-ip)[eth0]#reload
Running configuration has been changed.
Do you want to copy the 'running-config' to the 'startup-config'?
Press 'yes' to store, 'no' to drop changes : no
Press 'yes' to restart, 'no' to cancel : yes
The system is going down
```

## Bootloader

The bootloader ensures that basic operations, network access, and downloads are possible in case of interrupted or corrupted application image downloads. It offers console access to the Bootloader and the capability for downloading application images (e.g. SmartWare) via the serial link of the console.

### Start Bootloader

To start the Bootloader, power on the SmartNode while pressing the reset button. Open a Telnet session to the SmartNode via one of the Ethernet interfaces, or open a CLI session via the console port (if available on the SmartNode). The following prompt will be displayed:

```
RedBoot>
```

Type **help** to display an overview of the available commands.

### Start-up with factory configuration

Step	Command	Purpose
<b>1</b>	<b>RedBoot&gt; fis load</b>	Copies the SmartWare application image from the persistent memory (flash:) to the volatile memory (RAM) from where it will be executed.
<b>2</b>	<b>RedBoot&gt; go -s factory-config</b>	Starts the SmartWare application telling it to use 'factory-config' as startup configuration. You can also start-up with any other configuration available in the persistent memory (nvram:) by providing its name instead of 'factory-config'.

### Load a new application image (SmartWare) via TFTP

The following procedure downloads the application image (SmartWare) for the mainboard. See the note below on how to download the respective CLI description file.

Step	Command	Purpose
<b>1</b> <b>optional</b>	<b>RedBoot&gt; ip_address -l</b> <i>local_ip_address</i> [/mask_len]	Sets the IP address and subnet mask of the Ethernet interface 0/0 which shall be used to receive the new application image. <i>mask_len</i> is the length of the network address (or the number of 1's within the subnet mask). See Note below.
<b>2</b> <b>optional</b>	<b>RedBoot&gt; ip_address -g</b> <i>gateway</i>	Sets the IP address of the default gateway.
<b>3</b> <b>optional</b>	<b>RedBoot&gt; ping -h</b> <i>tftp-server_ip_address</i>	Tests the connectivity to the TFTP server.
<b>4</b>	<b>RedBoot&gt; load -r -v -h</b> <i>host -b</i> <i>base_address file_name</i>	Downloads an application image into the volatile memory (RAM) from where the SmartNode could directly execute it. <i>host</i> : IP address of the TFTP server <i>base_address</i> : memory location where to store the application image. Use the default address 0x1800100 <i>file_name</i> : path and name of the file on the TFTP server. Note: use the image file that contains the whole application, not the image parts.
<b>5</b>	<b>RedBoot&gt; fis delete -n 1</b>	Deletes the first application image. Reply with 'y' to the confirmation request.
<b>6</b>	<b>RedBoot&gt; fis create</b>	Stores the downloaded application image to the permanent memory (flash:). Reply with 'y' to the confirmation request.
<b>7</b>	<b>RedBoot&gt; fis list -l</b>	Checks whether the image has been successfully stored, whether it is the desired Release and Build, and whether it is valid.

Step	Command	Purpose
8	RedBoot> go	Starts the application image that was downloaded into the volatile memory (RAM).

**Note** With the Bootloader, only the Ethernet interface 0/0 is available. The Bootloader applies the IP address, subnet mask, and default gateway that were last configured by the Bootloader itself or by another application (e.g. SmartWare). If an application configured the Ethernet interface 0/0 to use DHCP, the Bootloader will also use DHCP to learn the interface configuration. It can receive and apply the IP address, subnet mask, default gateway, and default (TFTP) server (transmitted as basic DHCP information 'Next server IP address').

**Note** This procedure does not download the respective CLI description file. Download it after starting up SmartWare with the following command:  
copy tftp://<tftp\_server\_address>/<server\_path>/b1 flash:

**Example:** Downloading and storing a new application image (SmartWare)

```
RedBoot> ip -l 172.16.40.98/19
RedBoot> ip -g 172.16.32.1
RedBoot> ping -h 172.16.32.100
Network PING - from 172.16.40.98 to 172.16.32.100
.....PING - received 10 of 10 expected

RedBoot> load -r -v -h 172.16.32.100 -b 0x1800100 /Sn4xxx/image.bin
Using default protocol (TFTP)
-
Raw file loaded 0x01800100-0x0199ca6b, 1689964 bytes, assumed entry at 0x01800100

RedBoot> fis delete -n 1
Delete image 1 - continue (y/n)? y
... Erase from 0x60030000-0x601cc974: .....
```

```
RedBoot> fis create
Use address 0x01800100, size 1684402 ? - continue (y/n)? y
... Erase from 0x60030000-0x601cb3ba: .....
```

```
... Program from 0x00011eec-0x00011ef4 at 0x60030000: .
... Program from 0x01800100-0x0199b4b2 at 0x60030008: .....
... Program from 0x00011eec-0x00011ef4 at 0x60030000: .
Image successfully written to flash

RedBoot> fis list -l
Id Address      Length  State      Description
  Entry      Load Addr
-----
1  0x60030000 1693438 valid      SmartWare R2.10 BUILD28015
   0x01800100 0x01800100 V2.10

RedBoot> go
Starting 'SmartWare R2.10 BUILD28015' at 0x01800100 via 0x01800100
```

### Load a new application image (SmartWare) via the serial link

The Bootloader supports the 'X-Modem' and 'Y-Modem' protocols to download application images via the serial link of the console. Do the following to initiate the download:

Step	Command	Purpose
<b>1</b>	<b>RedBoot&gt; load -r -v -m { xmodem   ymodem } -b base_address</b>	Downloads an application image into the volatile memory (RAM) from where the SmartNode could directly execute it. 'xmodem' or 'ymodem': Specify the protocol to be used, X-Modem or Y-Modem <i>base_address</i> : memory location where to store the application image. Use the default address 0x1800100 Execute the above RedBoot command first, then start the transfer from the terminal program with the command 'Send file via X-Modem' (or similar).
<b>5</b>	RedBoot> fis delete -n 1	Deletes the first application image. Reply with 'y' to the confirmation request.
<b>6</b>	RedBoot> fis create	Stores the downloaded application image to the permanent memory (flash:). Reply with 'y' to the confirmation request.
<b>7</b>	RedBoot> fis list -l	Checks whether the image has been successfully stored, whether it is the desired Release and Build, and whether it is valid.
<b>8</b>	RedBoot> go	Starts the application image that was downloaded to the volatile memory (RAM).

**Note** This type of download takes about **25 minutes** since it uses a serial link at only 9600 bps.

### Additional information

For detailed information about configuring and operating guidance, set up procedures, and troubleshooting, refer to the *Software Configuration Guide* on the enclosed CD-ROM or the Patton website at [www.patton.com](http://www.patton.com). On the CD you will also find a freeware TFTP server, which is also available from the [www.solarwinds.net](http://www.solarwinds.net) web site.

# Chapter 5 **Contacting Patton for assistance**

## **Chapter contents**

- Introduction.....45
- Contact information.....45
- Warranty Service and Returned Merchandise Authorizations (RMAs).....45
  - Warranty coverage .....45
    - Out-of-warranty service .....46
    - Returns for credit .....46
    - Return for credit policy .....46
  - RMA numbers .....46
  - Shipping instructions .....46

## Introduction

---

This chapter contains the following information:

- “[Contact information](#)”—describes how to contact Patton technical support for assistance.
- “[Warranty Service and Returned Merchandise Authorizations \(RMAs\)](#)”—contains information about the SmartNode warranty and obtaining a return merchandise authorization (RMA).

## Contact information

---

Patton Electronics offers a wide array of free technical services. If you have questions about any of our other products we recommend you begin your search for answers by using our technical knowledge base. Here, we have gathered together many of the more commonly asked questions and compiled them into a searchable database to help you quickly solve your problems:

### Patton support headquarters in the USA

- Online support—available at [www.patton.com](http://www.patton.com)
- E-mail support—e-mail sent to [support@patton.com](mailto:support@patton.com) will be answered within 1 business day
- Telephone support—standard telephone support is available five days a week—from **8:00 am to 5:00 pm EST (1300 to 2200 UTC)**—by calling **+1 (301) 975-1007**

### Alternate Patton support for Europe, Middle East, and Africa (EMEA)

- Online support: available at [www.patton-inalp.com](http://www.patton-inalp.com)
- E-mail support: e-mail sent to [support@patton-inalp.com](mailto:support@patton-inalp.com) will be answered within 1 business day
- Telephone support: standard telephone support is available five days a week—from **8:00 am to 5:00 pm CET (0900 to 1800 UTC/GMT)** by calling **+41 (0)31 985 25 55**
- Fax: **+41 (0)31 985 25 26**

## Warranty Service and Returned Merchandise Authorizations (RMAs)

---

Patton Electronics is an ISO-9001 certified manufacturer and our products are carefully tested before shipment. All of our products are backed by a comprehensive warranty program.

**Note** If you purchased your equipment from a Patton Electronics reseller, ask your reseller how you should proceed with warranty service. It is often more convenient for you to work with your local reseller to obtain a replacement. Patton services our products no matter how you acquired them.

### Warranty coverage

Our products are under warranty to be free from defects, and we will, at our option, repair or replace the product should it fail within one year from the first date of shipment. Our warranty is limited to defects in workmanship or materials, and does not cover customer damage, lightning or power surge damage, abuse, or unauthorized modification.

### *Out-of-warranty service*

Patton services what we sell, no matter how you acquired it, including malfunctioning products that are no longer under warranty. Our products have a flat fee for repairs. Units damaged by lightning or other catastrophes may require replacement.

### *Returns for credit*

Customer satisfaction is important to us, therefore any product may be returned with authorization within 30 days from the shipment date for a full credit of the purchase price. If you have ordered the wrong equipment or you are dissatisfied in any way, please contact us to request an RMA number to accept your return. Patton is not responsible for equipment returned without a Return Authorization.

### *Return for credit policy*

- Less than 30 days: No Charge. Your credit will be issued upon receipt and inspection of the equipment.
- 30 to 60 days: We will add a 20% restocking charge (crediting your account with 80% of the purchase price).
- Over 60 days: Products will be accepted for repairs only.

### **RMA numbers**

RMA numbers are required for all product returns. You can obtain an RMA by doing one of the following:

- Completing a request on the RMA Request page in the *Support* section at **www.patton.com**
- By calling **+1 (301) 975-1007** and speaking to a Technical Support Engineer
- By sending an e-mail to **returns@patton.com**

All returned units must have the RMA number clearly visible on the outside of the shipping container. Please use the original packing material that the device came in or pack the unit securely to avoid damage during shipping.

### *Shipping instructions*

The RMA number should be clearly visible on the address label. Our shipping address is as follows:

#### **Patton Electronics Company**

RMA#: xxxx

7622 Rickenbacker Dr.

Gaithersburg, MD 20879-4773 USA

Patton will ship the equipment back to you in the same manner you ship it to us. Patton will pay the return shipping costs.

# Appendix A **Compliance information**

## **Chapter contents**

- Compliance .....48
  - EMC compliance: .....48
  - Safety compliance: .....48
- CE Declaration of Conformity .....48
- Authorized European Representative .....48

## Compliance

---

### **EMC compliance:**

- FCC Part 15, Class A
- EN55022, Class A
- EN55024
- EN-61000-3-2 Harmonics
- EN-61000-3-3 Flicker
- EN-61000-4-2 ESD
- EN-61000-4-3 Radiated Immunity
- EN-61000-4-4 EFT
- EN-61000-4-5 Surge
- EN-61000-4-6 Low Frequency Common Immunity
- EN-61000-4-11 Voltage Dips and Sags

### **Safety compliance:**

- UL60950-1/CSA C22.2 No. 60950-1
- IEC/EN 60950-1
- AS/NZS 60950-1

## CE Declaration of Conformity

---

This equipment conforms to the requirements of Council Directive 1999/5/EC on the approximation of the laws of the member states relating to Radio and Telecommunication Terminal Equipment and the mutual recognition of their conformity.

The safety advice in the documentation accompanying this product shall be obeyed. The conformity to the above directive is indicated by CE sign on the device.

The signed Declaration of Conformity can be downloaded at [www.patton.com/certifications](http://www.patton.com/certifications).

## Authorized European Representative

---

D R M Green  
European Compliance Services Limited.  
Avalon House, Marcham Road  
Abingdon,  
Oxon OX14 1UD, UK

## Appendix B **Specifications**

### **Chapter contents**

Voice connectivity - FXS .....	50
Ethernet interface .....	50
Console port.....	50
FXS ports .....	50
PPP and Frame-Relay support .....	50
Voice processing (signaling dependent) .....	50
Fax and modem support.....	51
Voice signaling .....	51
Voice routing-session router .....	52
IP services.....	52
Management .....	52
Operating environment .....	52
Temperature .....	52
Humidity .....	52
Altitude .....	53
System .....	53
Dimensions .....	53
Weight and power dissipation .....	53
Power supply .....	53
Universal AC version .....	53
DC version .....	53
Identification of the SmartNode devices via SNMP.....	54

## Voice connectivity - FXS

---

2-wire Loopstart, RJ-11/12

Short haul loop 1.1 km @3REN

EuroPOTS (ETSI EG201 188)

Programmable AC impedance, feeding, and ring voltage; on-hook voltage 48 VDC

Caller-ID Type-1/2 FSK and ITU V.23/Bell 202 generation

## Ethernet interface

---

The SN4400 series has dual 10/100-Mbps Ethernet ports presented on two RJ-45 connectors supporting:

- 100Base-TX half-/full-duplex operation
- 10Base-TX half-/full-duplex operation
- Auto detection and fallback

## Console port

---

The RS-232 port provides for initial configuration of the Model SN4400 series. The RS-232 port supports:

- Asynchronous data rate of 9600 bps, 2 bits, no parity, 1 stop bit, no flow control
- An RJ-45 connector with EIA-561 (RS-232) pinouts
- A management interface (such as HyperTerminal) that supports VT-100 terminals

## FXS ports

---

The FXS ports provide for connection of up to 32 analog FXS devices on a 50- or 64-pin RJ-21X connector located on the rear panel.

## PPP and Frame-Relay support

---

- Frame-Relay (8 PVCs)
- RFC1440, FRF.12 fragmentation
- LMI, Q.933D, ANSI 617D, Gang of Four (an encapsulation method created by the four companies: Cisco, Northern Telecom, StrataCom, and DEC which differs from the IETF encapsulation)
- PPP, PAP, CHAP, LCP, IPCP

## Voice processing (signaling dependent)

---

Voice codecs:

- G.711 A-Law/ -Law (64 kbps)
- G.726 (ADPCM 40, 32, 24, 16 kbps)
- G.723.1 (5.3 or 6.3 kbps)

- G.729ab (8 kbps)
- Transparent pass through
- G.168 echo cancellation
- Up to 32 parallel voice connections
- DTMF detection and generation
- Carrier tone detection and generation
- Silence suppression and comfort noise
- Configurable dejitter buffer
- Configurable tones (dial, ringing, busy)
- Configurable transmit packet length
- RTP/RTCP (RFC 1889)

## Fax and modem support

---

G.711 transparent FAX

Fax over IP (FoIP)

T.38 Fax relay (9.6 k, 14.4 k)

## Voice signaling

---

H.323v4:

- RAS, H.225, H.245
- Fast-connect, early H.245
- Gatekeeper autodiscovery
- Alias registration
- Overlap sending
- Empty capability set (call transfer, hold)
- H.323v1 call transfer, hold
- H.323 GW and GK compatible
- H.323 Annex M3

SIP:

- SIPv2 (RFC3261, RFC3263)
- SIP call transfer, redirect, DTMF relay

## Voice routing-session router

---

Local switching; Interface huntgroups

Routing Criteria:

- Interface
- Calling/called party number
- Time of day, day of week, date

Number manipulation functions:

- Replace numbers; Add/remove digits
- Multiple remote gateways; PLAR

## IP services

---

IPv4 router; RIPv1, v2 (RFC 1058 and 2453)

Programmable static routes

ICMP redirect (RFC 792); Packet fragmentation

DiffServe/ToS set or queue per header bits

Packet Policing discards excess traffic

802.1p VLAN tagging

IPSEC AH & ESP Modes

Manual Key; IKE optional

AES/DES/3DES Encryption

## Management

---

Industry standard CLI with local console (RJ-45, RS-232) and remote Telnet access

TFTP configuration & firmware loading

SNMP v1 agent (MIB II and private MIB)

Built-in diagnostic tools (trace, debug)

## Operating environment

---

### Temperature

Operating range: 32–104°F (0–40°C)

Internal temperature: Available in real-time on the IpChannel Bank web pages

### Humidity

5 to 90% relative humidity (RH), non-condensing

**Altitude**

Maximum operating altitude: 15,000 feet (4,752 meters)

**System**

- The processor is a Motorola MPC875 series 32-bit PowerPC core, 133 MHz
- 8 MB Flash
- 32 MB SDRAM

**Dimensions**

1.75 inches (4.44 cm) height, standard 19-inch (48.26 cm) width, 12 inches (30.48 cm) depth

**Weight and power dissipation**

See [table 8](#).

Table 8. SmartNode weight and maximum power specifications

SmartNode model	Weight	Maximum power dissipation
IpChannel Bank 4412	9.1 lb (4.1 kg)	25W
IpChannel Bank 4416	9.1 lb (4.1 kg)	30W
IpChannel Bank 4424	9.1 lb (4.1 kg)	40W
IpChannel Bank 4432	9.1 lb (4.1 kg)	50W

**Power supply****Universal AC version**

Internal power supply voltage range 100–240 VAC, 50/60 Hz via IEC-320 connectors. Current rating 5.4 A, 65W.

**DC version**

Optional DC power supply with -36 to -72VDC via terminal block, current rating 4.2 A at 12 VDC, 50W.

## Identification of the SmartNode devices via SNMP

All SmartNode devices have assigned sysObjectID (.iso.org.dod.internet.mgmt.mib-2.system.sysObjectID) numbers (see [table 9](#)).

Table 9. SmartNode Models and their Unique sysObjectID

SmartNode Model	SysObjectID
SN4408/JS/RUI	1.3.6.1.4.1.1768.2.4.12.1
SN4412/JS/RUI	1.3.6.1.4.1.1768.2.4.12.2
SN4416/JS/RUI	1.3.6.1.4.1.1768.2.4.12.3
SN4424/JS/RUI	1.3.6.1.4.1.1768.2.4.12.4
SN4432/JS/RUI	1.3.6.1.4.1.1768.2.4.12.5

According to [table 9](#), an SNMP get request to *.iso.org.dod.internet.mgmt.mib-2.system.sysObjectID* of a SmartNode 4412-JS device reads out a numeric OID of *1.3.6.1.4.1.1768.2.4.12.2*, which represents a SmartNode 4412 device. The mapping of the sysObjectID to each of the SmartNode model is realized with the SmartNode product identification MIB.



The SNMP agent running in SmartWare is SNMP version 1 (SNMPv1) compliant. SNMP version 2 (SNMPv2) and SNMP version 3 (SNMPv3) are not currently supported.

## Appendix C **Port pin-outs**

---

### **Chapter contents**

Introduction.....	56
Console port.....	56
Ethernet 10Base-T and 100Base-T port .....	56
FXS ports .....	57

## Introduction

This section provides pin-out information for the ports of the SmartNode.

### Console port

**Configuration settings:** Asynchronous data rate of 9600 bps, 2 bits, no parity, 1 stop bit, no flow control

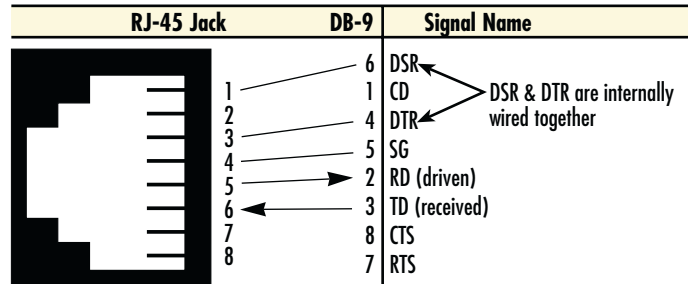

Figure 19. EIA-561 (RJ-45 8-pin) port

**Note** Pins not listed are not used.

### Ethernet 10Base-T and 100Base-T port

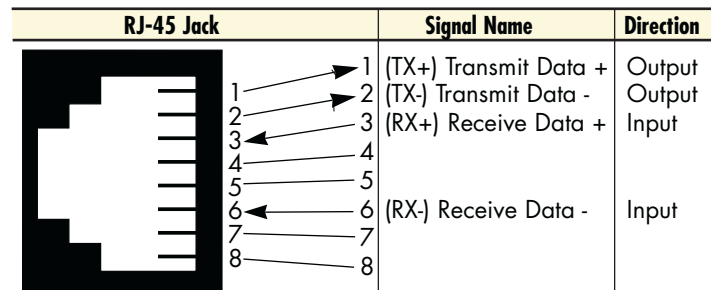

Figure 20. Model SN4400 Ethernet port

**Note** Pins not listed are not used.

## FXS ports

The FXS ports are accessed through a 64-pin RJ-21X connector (see [table 10](#) for pin-outs) or through a 50-pin RJ-21X connector (see [table 11](#) on page 59 for pin-outs) located on the rear panel of the IpChannel Bank.

Table 10. Band marked color-codes for the 64-pin RJ-21X connector

Wire/Color Code		Binder Color	Tip & Ring	Pair Number	64 Pin Positions
Main color	Stripe				
White	Blue	Blue	Tip 1	Pair 1	33
Blue	White	Blue	Ring 1		1
White	Orange	Blue	Tip 2	Pair 2	34
Orange	White	Blue	Ring 2		2
White	Green	Blue	Tip 3	Pair 3	35
Green	White	Blue	Ring 3		3
White	Brown	Blue	Tip 4	Pair 4	36
Brown	White	Blue	Ring 4		4
White	Slate	Blue	Tip 5	Pair 5	37
Slate	White	Blue	Ring 5		5
Red	Blue	Blue	Tip 6	Pair 6	38
Blue	Red	Blue	Ring 6		6
Red	Orange	Blue	Tip 7	Pair 7	39
Orange	Red	Blue	Ring 7		7
Red	Green	Blue	Tip 8	Pair 8	40
Green	Red	Blue	Ring 8		8
Red	Brown	Blue	Tip 9	Pair 9	41
Brown	Red	Blue	Ring 9		9
Red	Slate	Blue	Tip 10	Pair 10	42
Slate	Red	Blue	Ring 10		10
Black	Blue	Blue	Tip 11	Pair 11	43
Blue	Black	Blue	Ring 11		11
Black	Orange	Blue	Tip 12	Pair 12	44
Orange	Black	Blue	Ring 12		12
Black	Green	Blue	Tip 13	Pair 13	45
Green	Black	Blue	Ring 13		13
Black	Brown	Blue	Tip 14	Pair 14	46
Brown	Black	Blue	Ring 14		14
Black	Slate	Blue	Tip 15	Pair 15	47
Slate	Black	Blue	Ring 15		15
Yellow	Blue	Blue	Tip 16	Pair 16	48
Blue	Yellow	Blue	Ring 16		16

Table 10. Band marked color-codes for the 64-pin RJ-21X connector (Continued)

Wire/Color Code		Binder Color	Tip & Ring	Pair Number	64 Pin Positions
Main color	Stripe				
Yellow	Orange	Blue	Tip 17	Pair 17	44
Orange	Yellow	Blue	Ring 17		17
Yellow	Green	Blue	Tip 18	Pair 18	50
Green	Yellow	Blue	Ring 18		18
Yellow	Brown	Blue	Tip 19	Pair 19	51
Brown	Yellow	Blue	Ring 19		19
Yellow	Slate	Blue	Tip 20	Pair 20	52
Slate	Yellow	Blue	Ring 20		20
Purple	Blue	Blue	Tip 21	Pair 21	53
Blue	Purple	Blue	Ring 21		21
Purple	Orange	Blue	Tip 22	Pair 22	54
Orange	Purple	Blue	Ring 22		22
Purple	Green	Blue	Tip 23	Pair 23	55
Green	Purple	Blue	Ring 23		23
Purple	Brown	Blue	Tip 24	Pair 24	56
Brown	Purple	Blue	Ring 24		24
Purple	Slate	Blue	Tip 25	Pair 25	57
Slate	Purple	Blue	Ring 25		25
White	Blue	Orange	Tip 26	Pair 26	58
Blue	White	Orange	Ring 26		26
White	Orange	Orange	Tip 27	Pair 27	59
Orange	White	Orange	Ring 27		27
White	Green	Orange	Tip 28	Pair 28	60
Green	White	Orange	Ring 28		28
White	Brown	Orange	Tip 29	Pair 29	61
Brown	White	Orange	Ring 29		29
White	Slate	Orange	Tip 30	Pair 30	62
Slate	White	Orange	Ring 30		30
Red	Blue	Orange	Tip 31	Pair 31	63
Blue	Red	Orange	Ring 31		31
Red	Orange	Orange	Tip 32	Pair 32	64
Orange	Red	Orange	Ring 32		32

Table 11. Band marked color-codes for the 50-pin RJ-21X connector

Wire/Color Code		Tip & Ring	Pair Number	50 Pin Positions
Main color	Stripe			
White	Blue	Tip 1	Pair 1	26
Blue	White	Ring 1		1
White	Orange	Tip 2	Pair 2	27
Orange	White	Ring 2		2
White	Green	Tip 3	Pair 3	28
Green	White	Ring 3		3
White	Brown	Tip 4	Pair 4	29
Brown	White	Ring 4		4
White	Slate	Tip 5	Pair 5	30
Slate	White	Ring 5		5
Red	Blue	Tip 6	Pair 6	31
Blue	Red	Ring 6		6
Red	Orange	Tip 7	Pair 7	32
Orange	Red	Ring 7		7
Red	Green	Tip 8	Pair 8	33
Green	Red	Ring 8		8
Red	Brown	Tip 9	Pair 9	34
Brown	Red	Ring 9		9
Red	Slate	Tip 10	Pair 10	35
Slate	Red	Ring 10		10
Black	Blue	Tip 11	Pair 11	36
Blue	Black	Ring 11		11
Black	Orange	Tip 12	Pair 12	37
Orange	Black	Ring 12		12
Black	Green	Tip 13	Pair 13	38
Green	Black	Ring 13		13
Black	Brown	Tip 14	Pair 14	39
Brown	Black	Ring 14		14
Black	Slate	Tip 15	Pair 15	40
Slate	Black	Ring 15		15
Yellow	Blue	Tip 16	Pair 16	41
Blue	Yellow	Ring 16		16
Yellow	Orange	Tip 17	Pair 17	42
Orange	Yellow	Ring 17		17
Yellow	Green	Tip 18	Pair 18	43
Green	Yellow	Ring 18		18

Table 11. Band marked color-codes for the 50-pin RJ-21X connector (Continued)

Wire/Color Code		Tip & Ring	Pair Number	50 Pin Positions
Main color	Stripe			
<b>Yellow</b>	<b>Brown</b>	Tip 19	Pair 19	44
<b>Brown</b>	<b>Yellow</b>	Ring 19		19
<b>Yellow</b>	Slate	Tip 20	Pair 20	45
Slate	<b>Yellow</b>	Ring 20		20
<b>Violet</b>	<b>Blue</b>	Tip 21	Pair 21	46
<b>Blue</b>	<b>Violet</b>	Ring 21		21
<b>Violet</b>	<b>Orange</b>	Tip 22	Pair 22	47
<b>Orange</b>	<b>Violet</b>	Ring 22		22
<b>Violet</b>	<b>Green</b>	Tip 23	Pair 23	48
<b>Green</b>	<b>Violet</b>	Ring 23		23
<b>Violet</b>	<b>Brown</b>	Tip 24	Pair 24	44
<b>Brown</b>	<b>Violet</b>	Ring 24		24
<b>Violet</b>	Slate	Tip 25	Pair 25	50
Slate	<b>Violet</b>	Ring 25		25

# Appendix D **Factory Configuration**

---

## **Chapter contents**

Introduction.....	62
-------------------	----

## Introduction

---

The factory configuration settings for SmartNode 4400 Series devices are as follows:

```
#-----#
#
# 4400 Series
# Factory configuration file
#
#-----#

dns-relay
sntp-client
sntp-client server primary 129.132.2.21 port 123 version 4

system

ic voice 0
    low-bitrate-codec g729

profile napt NAPT

profile dhcp-server DHCP
network 192.168.1.0 255.255.255.0
include 1 192.168.1.10 192.168.1.99
lease 2 hours
default-router 1 192.168.1.1
domain-name-server 1 192.168.1.1

context ip router

interface eth0
    ipaddress dhcp
    use profile napt NAPT
    tcp adjust-mss rx mtu
    tcp adjust-mss tx mtu

interface eth1
    ipaddress 192.168.1.1 255.255.255.0
    tcp adjust-mss rx mtu
    tcp adjust-mss tx mtu

context ip router
    dhcp-server use DHCP

port ethernet 0 0
    medium auto
    encapsulation ip
    bind interface eth0 router
    no shutdown

port ethernet 0 1
    medium auto
    encapsulation ip
    bind interface eth1 router
    no shutdown
```

# Appendix E **End user license agreement**

## **Chapter contents**

- End User License Agreement .....64
  - 1. Definitions .....64
  - 2. Title .....64
  - 3. Term .....64
  - 4. Grant of License .....64
  - 5. Warranty .....64
  - 6. Termination .....65
  - 7. Other licenses .....65

## End User License Agreement

---

By opening this package, operating the Designated Equipment or downloading the Program(s) electronically, the End User agrees to the following conditions:

### 1. Definitions

- A) *Effective Date* shall mean the earliest date of purchase or download of a product containing the Patton Electronics Company Program(s) or the Program(s) themselves.
- B) *Program(s)* shall mean all software, software documentation, source code, object code, or executable code.
- C) *End User* shall mean the person or organization which has valid title to the Designated Equipment.
- D) *Designated Equipment* shall mean the hardware on which the Program(s) have been designed and provided to operate by Patton Electronics Company.

### 2. Title

Title to the Program(s), all copies of the Program(s), all patent rights, copyrights, trade secrets and proprietary information in the Program(s), worldwide, remains with Patton Electronics Company or its licensors.

### 3. Term

The term of this Agreement is from the Effective Date until title of the Designated Equipment is transferred by End User or unless the license is terminated earlier as defined in section “6. Termination” on page 65.

### 4. Grant of License

- A) During the term of this Agreement, Patton Electronics Company grants a personal, non-transferable, non-assignable and non-exclusive license to the End User to use the Program(s) only with the Designated Equipment at a site owned or leased by the End User.
- B) The End User may copy licensed Program(s) as necessary for backup purposes only for use with the Designated Equipment that was first purchased or used or its temporary or permanent replacement.
- C) The End User is prohibited from disassembling; decompiling, reverse-engineering or otherwise attempting to discover or disclose the Program(s), source code, methods or concepts embodied in the Program(s) or having the same done by another party.
- D) Should End User transfer title of the Designated Equipment to a third party after entering into this license agreement, End User is obligated to inform the third party in writing that a separate End User License Agreement from Patton Electronics Company is required to operate the Designated Equipment.

### 5. Warranty

The Program(s) are provided *as is* without warranty of any kind. Patton Electronics Company and its licensors disclaim all warranties, either express or implied, including but not limited to the implied warranties of merchantability, fitness for a particular purpose or non-infringement. In no event shall Patton Electronics Company or its licensors be liable for any damages whatsoever (including, without limitation, damages for loss of business profits, business interruption, loss of business information, or other pecuniary loss) arising out of the use of or inability to use the Program(s), even if Patton Electronics Company has been advised of the possibility of such damages. Because some states do not allow the exclusion or limitation of liability for consequential or incidental damages, the above limitation may not apply to you.

If the Program(s) are acquired by or on behalf of a unit or agency of the United States Government, the Government agrees that such Program(s) are *commercial computer software* or *computer software documentation* and that, absent a written agreement to the contrary, the Government's rights with respect to such Program(s) are limited by the terms of this Agreement, pursuant to Federal Acquisition Regulations 12.212(a) and/or DEARS 227.7202-1(a) and/or sub-paragraphs (a) through (d) of the "Commercial Computer Software - Restricted Rights" clause at 48 C.F.R. 52.227-19 of the Federal Acquisition Regulations as applicable.

## 6. Termination

- A) The End User may terminate this agreement by returning the Designated Equipment and destroying all copies of the licensed Program(s).
- B) Patton Electronics Company may terminate this Agreement should End User violate any of the provisions of section "4. Grant of License" on page 64.
- C) Upon termination for **A** or **B** above or the end of the Term, End User is required to destroy all copies of the licensed Program(s)

## 7. Other licenses

The Program may be subject to licenses extended by third parties. Accordingly, Patton Electronics Company licenses the Programs subject to the terms and conditions dictated by third parties. Third party software identified to the Programs includes:

- A routing license is included at no charge.
- MGCP and VPN capabilities will require the purchase of an additional license.
- The LGPL (Lesser General Public License) open source license distributed to you pursuant to the LGPL license terms (<http://www.gnu.org/licenses/lgpl.html>).
- RedBoot (Red Hat Embedded Debug and Bootstrap) embedded system debug/bootstrap environment from Red Hat distributed to you pursuant to the eCos license terms (<http://ecos.sourceware.org/license-overview.html>) and GNU General Public License (GPL) terms (<http://www.gnu.org/copyleft/gpl.html>). Source code is available upon request.

# Appendix F **Installation checklist**

---

## **Chapter contents**

Introduction.....	67
-------------------	----

## Introduction

This appendix lists the tasks for installing a SmartNode 4400 IpChannel Bank (see [table 12](#)). Make a copy of this checklist and mark the entries as you complete each task. For each IpChannel Bank, include a copy of the completed checklist in your site log.

Table 12. Installation checklist

Task	Verified by	Date
Network information available & recorded in site log		
Environmental specifications verified		
Site power voltages verified		
Installation site pre-power check completed		
Required tools available		
Additional equipment available		
All printed documents available		
SmartWare release & build number verified		
Rack, desktop, or wall mounting of chassis completed		
Initial electrical connections established		
ASCII terminal attached to console port		
Cable length limits verified		
Initial configuration performed		
Initial operation verified		

# Appendix G **Accessories**

---

## **Chapter contents**

Introduction.....	69
-------------------	----

## Introduction

The cables listed in [table 13](#) are available as accessories for the SmartNode 4400 Series products.

Table 13. Accessory cables

Description	Part Number
64-pin telco to open end cable, 6 ft/1.8 m (64-pin FSX port)	10443264-10
50-pin telco to open end cable, 20 ft/6 m	10-3096TM50-20
50-pin telco/16 ends RJ-11 cable, 6 ft/1.8 m	10-3096TM50/16RJ11-6
50-pin telco/16 ends RJ-45 cable, 6 ft/1.8 m	10-3096TM50/16RJ45-6
50-pin telco/50-pin telco cable, 6 ft/1.8 m	10-3096TM50/50-6