

SmartNode 4830 DSL Series **Analog VoIP Integrated Access Device**

User Manual



Approval

Models that are equipped with telecom interfaces have been approved for connection to the public telecommunication network as listed under PSTN regulatory compliance.

Important

This is a Class A device and is intended for use in a light industrial environment. It is not intended nor approved for use in an industrial or residential environment.

Sales Office: **+1 (301) 975-1000**
Technical Support: **+1 (301) 975-1007**
E-mail: **support@patton.com**
WWW: **www.patton.com**

Patton Electronics Company, Inc.

7622 Rickenbacker Drive
Gaithersburg, MD 20879 USA
Tel: +1 (301) 975-1000
Fax: +1 (301) 869-9293
Support: +1 (301) 975-1007
URL: www.patton.com
E-Mail: support@patton.com

Trademark Statement

The terms *SmartWare* and *SmartNode* are trademarks of Patton Electronics Company. All other trademarks presented in this document are the property of their respective owners.

Copyright © 2012, Patton Electronics Company. All rights reserved.

The information in this document is subject to change without notice. Patton Electronics assumes no liability for errors that may appear in this document.

Warranty Information

The software described in this document is furnished under a license and may be used or copied only in accordance with the terms of such license.

Patton Electronics warrants all SmartNode product components to be free from defects, and will—at our option—repair or replace the product should it fail within one year from the first date of the shipment.

This warranty is limited to defects in workmanship or materials, and does not cover customer damage, abuse or unauthorized modification. If the product fails to perform as warranted, your sole recourse shall be repair or replacement as described above. Under no condition shall **Patton Electronics** be liable for any damages incurred by the use of this product. These damages include, but are not limited to, the following: lost profits, lost savings and incidental or consequential damages arising from the use of or inability to use this product. **Patton Electronics** specifically disclaims all other warranties, expressed or implied, and the installation or use of this product shall be deemed an acceptance of these terms by the user.

Summary Table of Contents

- 1 General information 14
- 2 Hardware installation 20
- 3 Getting started with the SmartNode..... 30
- 4 DSL Basic Configuration 39
- 5 Contacting Patton for assistance 44
- A Compliance information 47
- B Specifications 51
- C Cabling 58
- D Port pin-outs 64
- E Installation checklist 68

Table of Contents

| | |
|---|-----------|
| Summary Table of Contents | 3 |
| Table of Contents | 4 |
| List of Figures | 7 |
| List of Tables | 8 |
| About this guide | 9 |
| Audience..... | 9 |
| Structure..... | 9 |
| Precautions | 10 |
| Safety when working with electricity | 11 |
| General observations | 12 |
| Typographical conventions used in this document..... | 13 |
| General conventions | 13 |
| 1 General information..... | 14 |
| SmartNode Model 4830 DSL Series Overview..... | 15 |
| Rear Panel | 16 |
| Port Descriptions | 17 |
| Reset button behavior | 17 |
| Model Versions | 18 |
| Front Panel | 19 |
| 2 Hardware installation..... | 20 |
| Planning the installation..... | 21 |
| Installation checklist | 22 |
| Site log | 23 |
| Network information | 23 |
| Network Diagram | 23 |
| IP related information | 23 |
| Software tools | 23 |
| Power source | 24 |
| Location and mounting requirements | 24 |
| Installing the VoIP IAD | 24 |
| Mounting the VoIP IAD | 24 |
| Connecting cables | 24 |
| Installing an interface cable on the VoIP IAD's FXS and FXO interface ports | 25 |
| Installing the Ethernet cable | 27 |
| Installing the DSL cable | 28 |
| Connecting to external power source | 29 |
| 3 Getting started with the SmartNode..... | 30 |
| Introduction..... | 31 |
| 1. Configure IP address | 32 |

| | |
|---|-----------|
| Power connection and default configuration | 32 |
| Connect with the PC's serial interface | 32 |
| Login | 33 |
| Changing the IP address | 33 |
| 2. Connect the SmartNode to the network..... | 34 |
| 3. Load configuration | 34 |
| Bootloader..... | 35 |
| Start Bootloader | 35 |
| Start-up with factory configuration | 36 |
| Load a new application image (SmartWare) via TFTP | 36 |
| Load a new application image (SmartWare) via the serial link | 38 |
| Additional information..... | 38 |
| 4 DSL Basic Configuration | 39 |
| Introduction..... | 40 |
| Line Setup..... | 40 |
| Configuring PPPoE..... | 40 |
| Configuration Summary..... | 41 |
| Setting up permanent virtual circuits (PVC)..... | 42 |
| Using PVC channels in bridged Ethernet mode | 42 |
| Using PVC channels with PPPoE | 42 |
| Diagnostics | 43 |
| Troubleshooting DSL Connections..... | 43 |
| 5 Contacting Patton for assistance | 44 |
| Introduction..... | 45 |
| Contact information..... | 45 |
| Patton support headquarters in the USA | 45 |
| Alternate Patton support for Europe, Middle East, and Africa (EMEA) | 45 |
| Warranty Service and Returned Merchandise Authorizations (RMAs)..... | 45 |
| Warranty coverage | 45 |
| Out-of-warranty service | 46 |
| Returns for credit | 46 |
| Return for credit policy | 46 |
| RMA numbers | 46 |
| Shipping instructions | 46 |
| A Compliance information | 47 |
| Compliance..... | 48 |
| EMC compliance: | 48 |
| Safety compliance: | 48 |
| PSTN regulatory compliance: | 48 |
| Radio and TV Interference (FCC Part 15) | 48 |
| FCC Part 68 (ACTA) Statement (FXO ports)..... | 49 |
| Industry Canada Notice (FXO ports) | 49 |
| CE Notice | 50 |

| | |
|---|-----------|
| Authorized European Representative | 50 |
| B Specifications | 51 |
| DSP..... | 52 |
| Voice connectivity | 52 |
| Ethernet interface | 52 |
| ADSL Daughter Card (if applicable) | 52 |
| G.SHDSL Daughter Card (if applicable)..... | 53 |
| PPP and Frame-Relay support | 53 |
| Voice processing (signaling dependent) | 54 |
| Fax and modem support..... | 54 |
| Voice signaling | 54 |
| Voice routing—session product..... | 55 |
| IP services..... | 55 |
| Management | 55 |
| Operating environment | 56 |
| Operating temperature | 56 |
| Operating humidity | 56 |
| System | 56 |
| Dimensions | 56 |
| Weight and power dissipation | 56 |
| Power supply..... | 56 |
| Identification of the SmartNode devices via SNMP..... | 57 |
| C Cabling | 58 |
| Introduction | 59 |
| Serial console..... | 59 |
| Ethernet 10Base-T and 100Base-T | 60 |
| Analog FXS | 61 |
| Analog FXO | 62 |
| DSL..... | 63 |
| D Port pin-outs | 64 |
| Introduction | 65 |
| Console port..... | 65 |
| Ethernet 10Base-T and 100Base-T port | 65 |
| FXS port..... | 66 |
| FXO port | 66 |
| ADSL/G.SHDSL port..... | 67 |
| 2GS Models (RJ-45) | 67 |
| ADSL and GS Models (RJ-11) | 67 |
| E Installation checklist | 68 |
| Introduction..... | 69 |

List of Figures

| | | |
|----|--|----|
| 1 | SmartNode 4838 with DSL shown | 15 |
| 2 | SmartNode 4830 DSL Series connectors | 16 |
| 3 | SmartNode 4830 DSL Series front panel | 19 |
| 4 | Rear view showing location of Ethernet and FXS connectors (SmartNode 4838 shown) | 25 |
| 5 | Analog FXS connection | 25 |
| 6 | RJ-11 pinout diagram | 26 |
| 7 | Analog FXO connection | 27 |
| 8 | Connecting a SmartNode 4830 DSL Series device to a hub | 28 |
| 9 | Power connector location on rear panel | 29 |
| 10 | Steps for setting up a new SmartNode | 31 |
| 11 | Connecting to the terminal | 32 |
| 12 | Connecting the SmartNode to the network | 34 |
| 13 | Configuring the G.SHDSL card for PPPoE | 40 |
| 14 | Connecting a serial terminal | 59 |
| 15 | Ethernet straight-through | 60 |
| 16 | Connecting an FXS device | 61 |
| 17 | Connecting to an FXO line socket | 62 |
| 18 | Connecting the DSL cable | 63 |
| 19 | EIA-561 (RJ-45 8-pin) port | 65 |

List of Tables

| | | |
|----|---|----|
| 1 | General conventions | 13 |
| 2 | Rear panel ports | 17 |
| 3 | SmartNode 4830 DSL Series Model Codes | 18 |
| 4 | SmartNode LED Indications | 19 |
| 5 | Installation checklist | 22 |
| 6 | Sample site log entries | 23 |
| 7 | RJ-11 socket | 26 |
| 8 | Ethernet 10/100Base-T (RJ-45) port pin-outs | 27 |
| 9 | Factory default IP address and network mask configuration | 32 |
| 10 | PVC Commands | 42 |
| 11 | PVC channels in bridged Ethernet mode | 42 |
| 12 | PVC channels in PPPoE mode | 42 |
| 13 | Diagnostics commans | 43 |
| 14 | G.SHDSL Daughter Card Specifications | 53 |
| 15 | SmartNode weight and maximum power specifications | 56 |
| 16 | SmartNode Models and their Unique sysObjectID | 57 |
| 17 | RJ-45 socket | 65 |
| 18 | RJ-11 socket | 66 |
| 19 | RJ-11 socket | 66 |
| 20 | RJ-45 DSL port | 67 |
| 21 | RJ-11 DSL port | 67 |
| 22 | Installation checklist | 69 |

About this guide

This guide describes the SmartNode 4830 hardware, installation and basic configuration. For detailed software configuration information refer to the *SmartWare Software Configuration Guide* and the available Configuration Notes.

Audience

This guide is intended for the following users:

- Operators
- Installers
- Maintenance technicians

Structure

This guide contains the following chapters and appendices:

- [Chapter 1](#) on page 14 provides information about product features and capabilities
- [Chapter 2](#) on page 20 provides hardware installation procedures
- [Chapter 3](#) on page 30 provides quick-start procedures for configuring the SmartNode product
- [Chapter 4](#) on page 39 provides information on configuring DSL
- [Chapter 5](#) on page 44 contains information on contacting Patton technical support for assistance
- [Appendix A](#) on page 47 contains compliance information
- [Appendix B](#) on page 51 contains specifications for the products
- [Appendix C](#) on page 58 provides cable recommendations
- [Appendix D](#) on page 64 describes the product's ports and pin-outs
- [Appendix E](#) on page 68 provides an installation checklist for the SmartNode 4830

For best results, read the contents of this guide *before* you install the product.

Precautions

Notes, cautions, and warnings, which have the following meanings, are used throughout this guide to help you become aware of potential problems. **Warnings** are intended to prevent safety hazards that could result in personal injury. **Cautions** are intended to prevent situations that could result in property damage or impaired functioning.

Note A note presents additional information or interesting sidelights.



IMPORTANT

The alert symbol and IMPORTANT heading calls attention to important information.



CAUTION

The alert symbol and CAUTION heading indicate a potential hazard. Strictly follow the instructions to avoid property damage.



CAUTION

The shock hazard symbol and CAUTION heading indicate a potential electric shock hazard. Strictly follow the instructions to avoid property damage caused by electric shock.



WARNING

The alert symbol and WARNING heading indicate a potential safety hazard. Strictly follow the warning instructions to avoid personal injury.



WARNING

The shock hazard symbol and WARNING heading indicate a potential electric shock hazard. Strictly follow the warning instructions to avoid injury caused by electric shock.

Safety when working with electricity



- Do not open the device when the power cord is connected. For systems without a power switch and without an external power adapter, line voltages are present within the device when the power cord is connected.
- For devices with an external power adapter, the power adapter shall be a listed *Limited Power Source*. The mains outlet that is utilized to power the device shall be within 10 feet (3 meters) of the device, shall be easily accessible, and protected by a circuit breaker in compliance with local regulatory requirements.
- For AC powered devices, ensure that the power cable used meets all applicable standards for the country in which it is to be installed.
- For AC powered devices which have 3 conductor power plugs (L1, L2 & GND or Hot, Neutral & Safety/Protective Ground), the wall outlet (or socket) must have an earth ground.
- For DC powered devices, ensure that the interconnecting cables are rated for proper voltage, current, anticipated temperature, flammability, and mechanical serviceability.
- WAN, LAN & PSTN ports (connections) may have hazardous voltages present regardless of whether the device is powered ON or OFF. PSTN relates to interfaces such as telephone lines, FXS, FXO, DSL, xDSL, T1, E1, ISDN, Voice, etc. These are known as "hazardous network voltages" and to avoid electric shock use caution when working near these ports. When disconnecting cables for these ports, detach the far end connection first.
- Do not work on the device or connect or disconnect cables during periods of lightning activity



This device contains no user serviceable parts. This device can only be repaired by qualified service personnel.



In accordance with the requirements of council directive 2002/96/EC on Waste of Electrical and Electronic Equipment (WEEE), ensure that at end-of-life you separate this product from other waste and scrap and deliver to the WEEE collection system in your country for recycling.

**CAUTION**

Always follow ESD prevention procedures when removing and replacing cards.

Wear an ESD-preventive wrist strap, ensuring that it makes good skin contact. Connect the clip to an unpainted surface of the chassis frame to safely channel unwanted ESD voltages to ground.

To properly guard against ESD damage and shocks, the wrist strap and cord must operate effectively. If no wrist strap is available, ground yourself by touching the metal part of the chassis.

General observations

- Clean the case with a soft slightly moist anti-static cloth
- Place the unit on a flat surface and ensure free air circulation
- Avoid exposing the unit to direct sunlight and other heat sources
- Protect the unit from moisture, vapors, and corrosive liquids

Typographical conventions used in this document

This section describes the typographical conventions and terms used in this guide.

General conventions

The procedures described in this manual use the following text conventions:

Table 1. General conventions

| Convention | Meaning |
|-------------------------------|---|
| Garamond blue type | Indicates a cross-reference hyperlink that points to a figure, graphic, table, or section heading. Clicking on the hyperlink jumps you to the reference. When you have finished reviewing the reference, click on the Go to Previous View button  in the Adobe® Acrobat® Reader toolbar to return to your starting point. |
| Futura bold type | Commands and keywords are in boldface font. |
| Futura bold-italic type | Parts of commands, which are related to elements already named by the user, are in boldface italic font. |
| <i>Italicized Futura type</i> | Variables for which you supply values are in <i>italic</i> font |
| Futura type | Indicates the names of fields or windows. |
| Garamond bold type | Indicates the names of command buttons that execute an action. |
| < > | Angle brackets indicate function and keyboard keys, such as <SHIFT>, <CTRL>, <C>, and so on. |
| [] | Elements in square brackets are optional. |
| { a b c } | Alternative but required keywords are grouped in braces ({ }) and are separated by vertical bars () |
| blue screen | Information you enter is in blue screen font. |
| screen | Terminal sessions and information the system displays are in screen font. |
| node | The leading IP address or nodename of a SmartNode is substituted with node in boldface italic font. |
| SN | The leading SN on a command line represents the nodename of the SmartNode |
| # | An hash sign at the beginning of a line indicates a comment line. |

Chapter 1 **General information**

Chapter contents

| | |
|--|----|
| SmartNode Model 4830 DSL Series Overview | 15 |
| Rear Panel | 16 |
| Port Descriptions | 17 |
| Reset button behavior | 17 |
| Model Versions | 18 |
| Front Panel | 19 |

SmartNode Model 4830 DSL Series Overview

The SmartNode 4830 DSL Series Analog VoIP Integrated Access Devices combines IP routing, VPN/Security, and Quality of Service with integrated WAN access for up to 8 voice and FAX calls over any IP or PSTN network. Leverage low-cost IP services with packet-voice and WAN connectivity for complete branch-office voice-and-data networking.



Figure 1. SmartNode 4838 with DSL shown

The SmartNode 4830 DSL Series Analog VoIP Integrated Access Devices comes equipped with one 10/100Base-T Ethernet port and an integrated ADSL or G.SHDSL port to provide voice-over-IP (VoIP) and Internet telephony integrated with routed WAN access. The SN4830 IAD series supports Frame-Relay and PPP networking with VPN and firewall functions, and provides extensive Quality of Service (QoS) features for best-possible voice quality over any broadband IP network.

The SmartNode VoIP IAD performs the following major functions:

- Voice over IP and local switching via a combination of 2 to 8 analog phone ports (FXS) and 2 to 4 analog line ports (FXO).
- Standards-compliant conversion between analog voice and digital VoIP in accordance with SIP and H.323 protocols.
- Internet access and IP Routing with IP Quality of Service (QoS) support for mixed voice and data traffic.
- Routed LAN-to-WAN connectivity between the 10/100 Ethernet LAN port and an ADSL or G.SHDSL interface.

Rear Panel

Figure 2 shows one version of the SN4830 DSL series rear panel. Available with various combinations of FXS and FXO ports, this compact analog VoIP and WAN Integrated Access Device supports 2, 4, 6, or 8 VoIP calls.

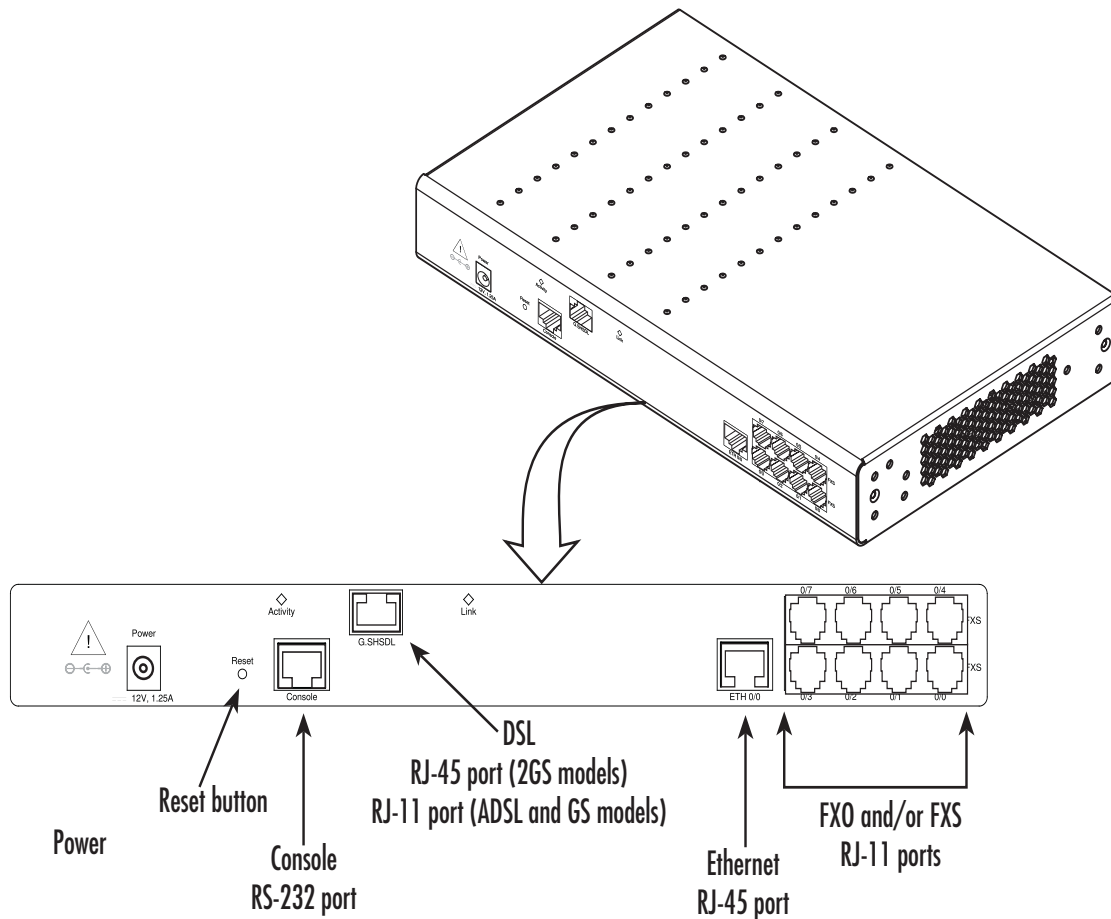

Figure 2. SmartNode 4830 DSL Series connectors

Each model within the SN4830 DSL Series comes equipped with one 10/100Base-T Ethernet port and an integrated ADSL or G.SHDSL port. The following base model numbers are available:

- SmartNode 4832 (2 VoIP calls)
- SmartNode 4834 (4 VoIP calls)
- SmartNode 4836 (6 VoIP calls)
- SmartNode 4838 (8 VoIP calls)

Port Descriptions

The SmartNode 4830 DSL Series rear-panel ports are described in [Table 2](#).

Table 2. Rear panel ports

| Port | Location | Description |
|----------------------------|-------------|--|
| 10/100 Ethernet ETH 0/0 | Rear panel | RJ-45 connector that connects the SmartNode to an Ethernet device (e.g., a cable or DSL modem, LAN hub or switch). |
| Analog voice port, FXS | Rear panel | FXS RJ-11 (6 position, 4 wire) connectors that connect the product with an analog terminal (a telephone, for example) FXO port. EuroPOTS support (ETSI EG201 188). |
| Analog voice port, FXO | Rear panel | FXO RJ-11 (6 position, 4 wire) connectors that connect the product with an analog line (FXS port). EuroPOTS support (ETSI EG201 188). |
| G.SHDSL or ADSL port | Rear panel | Provides up to 11.4 Mbps (G.SHDSL) or 24 Mbps (ADSL) throughput, supporting ATM QoS. Supports multiple PVC and DSLAM interoperability. The DSL LEDs are located on either side of the DSL port. ACT (when lit or blinking) shows Activity, and LINK (when lit) shows that the DSL port is connected. |
| Power | Rear panel | The gateway is available in a DC or AC power input version, labeled 100–240 VAC, 50/60 Hz, 200 mA |
| Console | Front panel | Used for service and maintenance, the Console port, an RS-232 RJ-45 connector, connects the product to a serial terminal such as a PC or ASCII terminal (also called a dumb terminal). |

Reset button behavior

For those SmartNode devices that have a *Reset* button on the rear panel, its behavior is as follows:

- To restart the unit with the current startup configuration—Press for less than 1 second and release the *Reset* button. The SmartNode will restart with the current startup configuration.
- To restart the unit with factory default configuration—Press the *Reset* button for 5 seconds until the Power LED starts blinking. The unit will restart with factory default configuration.
- To restart the unit in bootloader mode (to be used only by trained SmartNode technicians)—Start with the unit powered off. Press and hold the *Reset* button while applying power to the unit. Release the *Reset* button when the *Power* LED starts blinking so the unit will enter bootloader mode.

Model Versions

A model-code extension indicates the combination of ports the SN4830 provides. [Table 3](#) describes the available model versions in the SN4830 DSL Series.

Table 3. SmartNode 4830 DSL Series Model Codes

| | Model Code | DSL Type | FXS (JS) | FXO (JO) | Voice Calls |
|---------------|----------------------------|-----------------|-----------------|-----------------|--------------------|
| SN4832 | SN4832/JS2GS/EUI | G.SHDSL (2) | 2 | 0 | 2 |
| | SN4832/JSAA/EUI | ADSL (Annex A) | 2 | 0 | 2 |
| | SN4832/JSAB/EUI | ADSL (Annex B) | 2 | 0 | 2 |
| | SN4832/JSGS/EUI | G.SHDSL (1) | 2 | 0 | 2 |
| SN4834 | SN4834/2JS2JOAA/EUI | ADSL (Annex A) | 2 | 2 | 4 |
| | SN4834/2JS2JOAB/EUI | ADSL (Annex B) | 2 | 2 | 4 |
| | SN4834/2JS2JOGS/EUI | G.SHDSL (1) | 2 | 2 | 4 |
| | SN4834/JS2GS/EUI | G.SHDSL (2) | 4 | 0 | 4 |
| | SN4834/JSAA/EUI | ADSL (Annex A) | 4 | 0 | 4 |
| | SN4834/JSAB/EUI | ADSL (Annex B) | 4 | 0 | 4 |
| | SN4834/JSGS/EUI | G.SHDSL (1) | 4 | 0 | 4 |
| SN4836 | SN4836/4JS2JOAA/EUI | ADSL (Annex A) | 4 | 2 | 6 |
| | SN4836/4JS2JOAB/EUI | ADSL (Annex B) | 4 | 2 | 6 |
| | SN4836/4JS2JOGS/EUI | G.SHDSL (1) | 4 | 2 | 6 |
| | SN4836/JS2GS/EUI | G.SHDSL (2) | 6 | 0 | 6 |
| | SN4836/JSAA/EUI | ADSL (Annex A) | 6 | 0 | 6 |
| | SN4836/JSAB/EUI | ADSL (Annex B) | 6 | 0 | 6 |
| | SN4836/JSGS/EUI | G.SHDSL (1) | 6 | 0 | 6 |
| SN4838 | SN4838/4JS4JOAA/EUI | ADSL (Annex A) | 4 | 4 | 8 |
| | SN4838/4JS4JOAB/EUI | ADSL (Annex B) | 4 | 4 | 8 |
| | SN4838/4JS4JOGS/EUI | G.SHDSL (1) | 4 | 4 | 8 |
| | SN4838/JS2GS/EUI | G.SHDSL (2) | 8 | 0 | 8 |
| | SN4838/JSAA/EUI | ADSL (Annex A) | 8 | 0 | 8 |
| | SN4838/JSAB/EUI | ADSL (Annex B) | 8 | 0 | 8 |
| | SN4838/JSGS/EUI | G.SHDSL (1) | 8 | 0 | 8 |

Front Panel

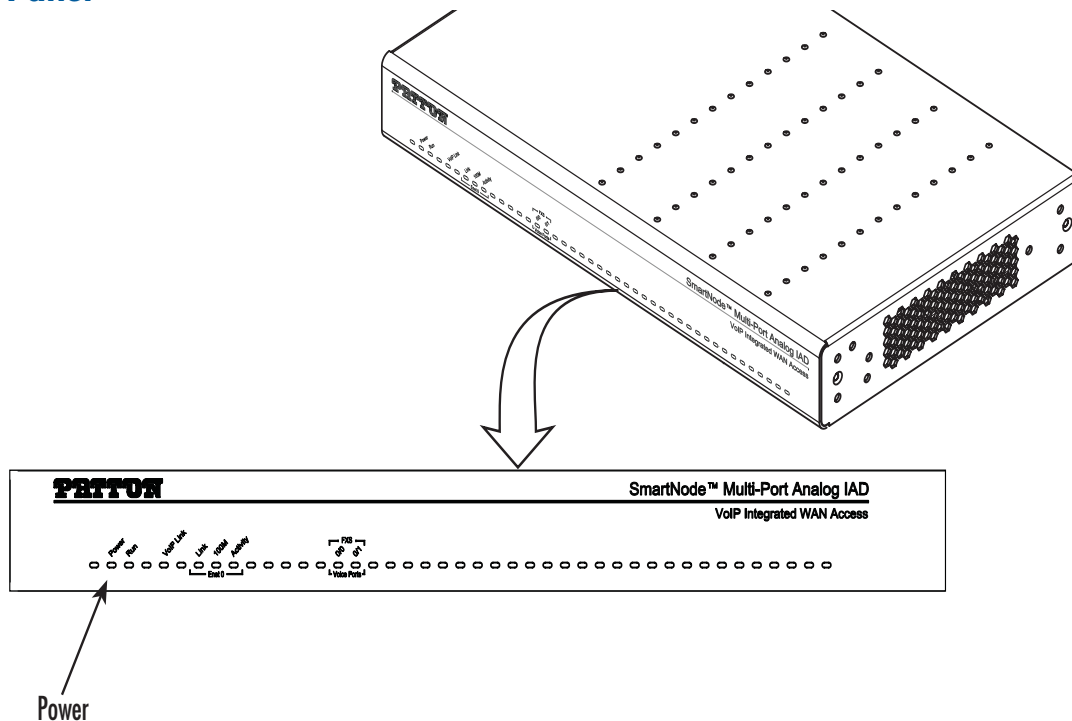

Figure 3. SmartNode 4830 DSL Series front panel

Table 4. SmartNode LED Indications

| LED | Description |
|--|--|
| Note If an error occurs, all LEDs will flash once per second. | |
| Power | When lit, indicates power is applied. Off indicates no power applied. |
| Run | When lit, indicates normal operation. Flashes once per second during boot (startup). |
| VoIP Link | When lit, indicates the gateway is registered on a gatekeeper, media gateway controller, associated to a remote unit, or has an active VoIP connection. Off indicates the unit is not configured or registered and has no active VoIP connection. Flashing green indicates that the unit is attempting or has failed to associate/register |
| FXS (each port) | Off indicates on-hook condition. Solid green when off-hook. Flashes to follow ring cadence. |
| FXO (each port) | Off indicates on-hook condition. Solid green when off-hook. Flashes to follow ring cadence. |
| Ethernet | <ul style="list-style-type: none"> Link: Lit when Ethernet link is up. 100M: On when 100-Mbps Ethernet is selected. Activity: Flashes when data is received or transmitted from the unit to the LAN. |

Chapter 2 **Hardware installation**

Chapter contents

| | |
|---|----|
| Planning the installation | 21 |
| Installation checklist | 22 |
| Site log | 23 |
| Network information | 23 |
| Network Diagram | 23 |
| IP related information | 23 |
| Software tools | 23 |
| Power source | 24 |
| Location and mounting requirements | 24 |
| Installing the VoIP IAD | 24 |
| Mounting the VoIP IAD | 24 |
| Connecting cables | 24 |
| Installing an interface cable on the VoIP IAD's FXS and FXO interface ports | 25 |
| Installing the Ethernet cable | 27 |
| Installing the DSL cable | 28 |
| Connecting to external power source | 29 |

Planning the installation

Before you start the actual installation, we strongly recommend that you gather all the information you will need to install and setup the device. See [table 5](#) for an example of what pre-installment checks you might need to carry out. Completing the pre-installation checks enables you to install and set up your VoIP IAD within an existing network infrastructure with confidence.



Mains Voltage: Do not open the case when the power cord is connected. For systems without a power switch, line voltages are present within the power supply when the power cord is connected. The mains outlet that is utilized to power the SmartNode router shall be within 10 feet (3 meters) of the device, shall be easily accessible, and protected by a circuit breaker.

Note When setting up your VoIP IAD you must consider cable-length limitations, and potential electromagnetic interference (EMI) as defined by the applicable local and international regulations. Ensure that your site is properly prepared before beginning installation.

Before installing the VoIP IAD device, the following tasks should be completed:

- **Create a network diagram** (see section “[Network information](#)” on page 23)
- **Gather IP related information** (see section “[IP related information](#)” on page 23 for more information)
- **Install the hardware and software needed to configure the SmartNode.** (See section “[Software tools](#)” on page 23)
- **Verify power source reliability** (see section “[Power source](#)” on page 24).

When you finish preparing for your VoIP IAD installation, go to section “[Installing the VoIP IAD](#)” on page 24 to install the device.

Installation checklist

The installation checklist (see [table 5](#)) lists the tasks for installing a SmartNode 4830 DSL Series VoIP IAD. Make a copy of this checklist and mark the entries as you complete each task. For each SmartNode 4830 DSL Series VoIP IAD, include a copy of the completed checklist in your site log.

Table 5. Installation checklist

| Task | Verified by | Date |
|--|-------------|------|
| Network information available & recorded in site log | | |
| Environmental specifications verified | | |
| Site power voltages verified | | |
| Installation site pre-power check completed | | |
| Required tools available | | |
| Additional equipment available | | |
| All printed documents available | | |
| SmartWare release & build number verified | | |
| Rack, desktop, or wall mounting of chassis completed | | |
| Initial electrical connections established | | |
| ASCII terminal attached to console port | | |
| Cable length limits verified | | |
| Initial configuration performed | | |
| Initial operation verified | | |

Site log

Patton recommends that you maintain a site log to record all actions relevant to the system, if you do not already keep such a log. Site log entries should include information such as listed in [table 6](#).

Table 6. Sample site log entries

| Entry | Description |
|--------------------------|---|
| Installation | Make a copy of the installation checklist and insert it into the site log |
| Upgrades and maintenance | Use the site log to record ongoing maintenance and expansion history |
| Configuration changes | Record all changes and the reasons for them |
| Maintenance | Schedules, requirements, and procedures performed |
| Comments | Notes, and problems |
| Software | Changes and updates to SmartWare software |

Network information

When planning your installation there are certain network-connection considerations that you should take into account. The following sections describe such considerations for several types of network interfaces.

Network Diagram

Draw a network overview diagram that displays all neighboring IP nodes, connected elements and telephony components.

IP related information

Before you can set up the basic IP connectivity for your SmartNode 4830 DSL Series you should have the following information:

- IP address used for Ethernet port
- Subnet mask used for Ethernet port
- Frame Relay PVC DLCI or PPP parameters
- IP addresses used for the DSL port
- Subnet mask used for the DSL port
- IP addresses of central H.323 Gatekeeper (if used)
- IP addresses of central PSTN Gateway for H.323 and/or ISoIP based calls
- IP addresses of central TFTP Server used for configuration upload and download

Software tools

You will need a PC (or equivalent) with a VT-100 emulation program (e.g. HyperTerminal) to configure the software on your SmartNode VoIP IAD.

Power source

If you suspect that your AC power is not reliable, for example if room lights flicker often or there is machinery with large motors nearby, have a qualified professional test the power. Install a power conditioner if necessary.

Location and mounting requirements

The SmartNode VoIP IAD is intended to be placed on a desktop or similar sturdy, flat surface that offers easy access to the cables. Allow sufficient space at the rear of the chassis for cable connections. Additionally, you should consider the need to access the unit for future upgrades and maintenance.

Installing the VoIP IAD

SmartNode VoIP IAD installation consists of the following:

- Placing the device at the desired installation location (see section “Mounting the VoIP IAD” on page 24)
- Installing the interface and power cables (see section “Connecting cables” on page 24)

When you finish installing the SmartNode, go to chapter 3, “Getting started with the SmartNode” on page 30.

Mounting the VoIP IAD

Place the VoIP IAD on a desktop or similar sturdy, flat surface that offers easy access to the cables. The VoIP IAD should be installed in a dry environment with sufficient space to allow air circulation for cooling.

Note For proper ventilation, leave at least 2 inches (5 cm) to the left, right, front, and rear of the SmartNode VoIP IAD.

Connecting cables



Do not work on the system or connect or disconnect cables during periods of lightning activity.



The interconnecting cables shall be acceptable for external use and shall be rated for the proper application with respect to voltage, current, anticipated temperature, flammability, and mechanical serviceability.

Installing VoIP IAD cables takes place in the following order:

1. Installing the RJ-11 voice port (FXS) cable or cables (see section “Installing an interface cable on the VoIP IAD’s FXS and FXO interface ports” on page 25)
2. Installing the 10/100 Ethernet port cable (see section “Installing the Ethernet cable” on page 27)
3. Installing the DSL cable (see section “Installing the DSL cable” on page 28)
4. Installing the power input (see section “Connecting to external power source” on page 29)

Installing an interface cable on the VoIP IAD's FXS and FXO interface ports

The gateway comes with at least two FXS or FXO analog ports—or a combination of FXS and FXO ports—located on the back of the VoIP IAD (see figure 4). The FXS interfaces are connected to analog devices via cables (see figure 5) terminated with RJ-11 connectors (see figure 6 and table 7 on page 26 for pin-out information). The FXO interface connects the VoIP IAD with analog lines via cables (see figure 7 on page 27) terminated with RJ-11 connectors (see figure 6 and table 7 on page 26 for pin-out information).

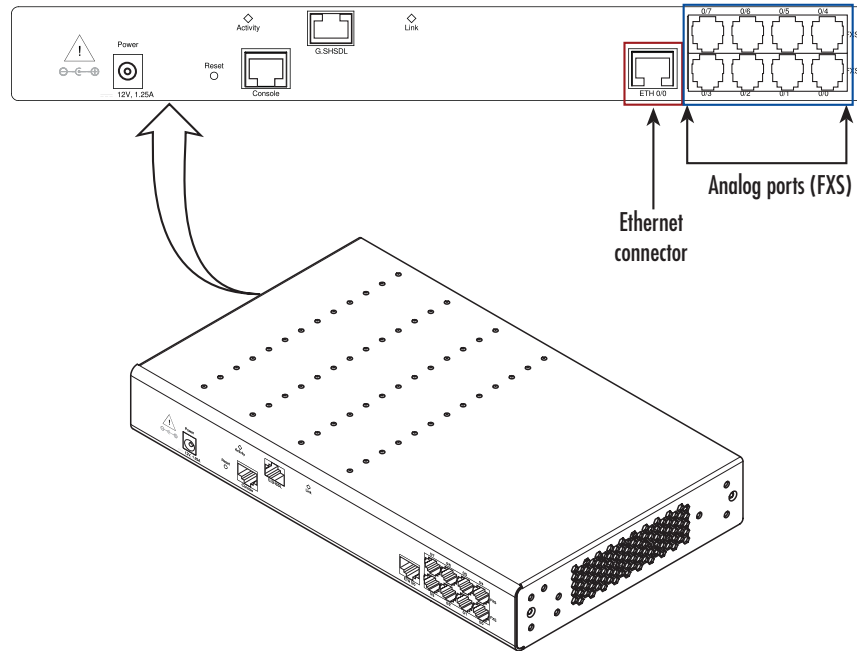

Figure 4. Rear view showing location of Ethernet and FXS connectors (SmartNode 4838 shown)

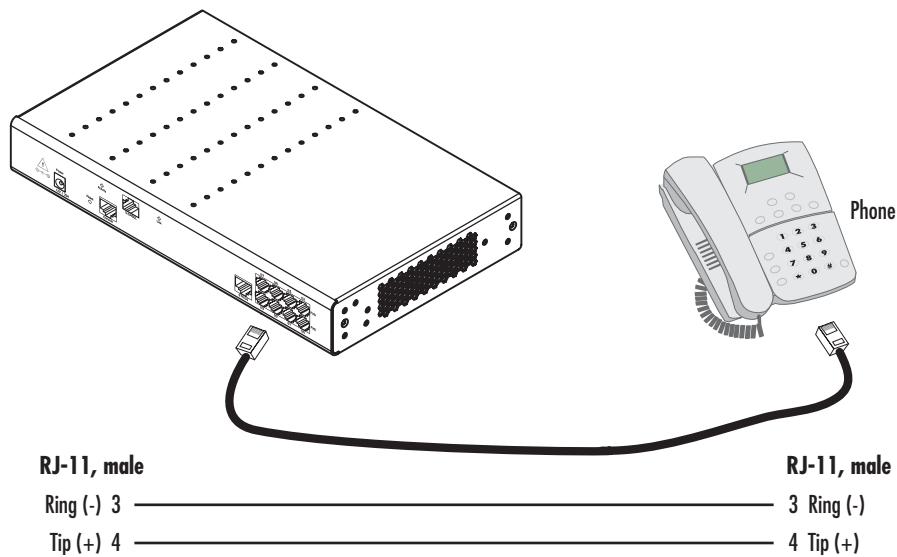

Figure 5. Analog FXS connection

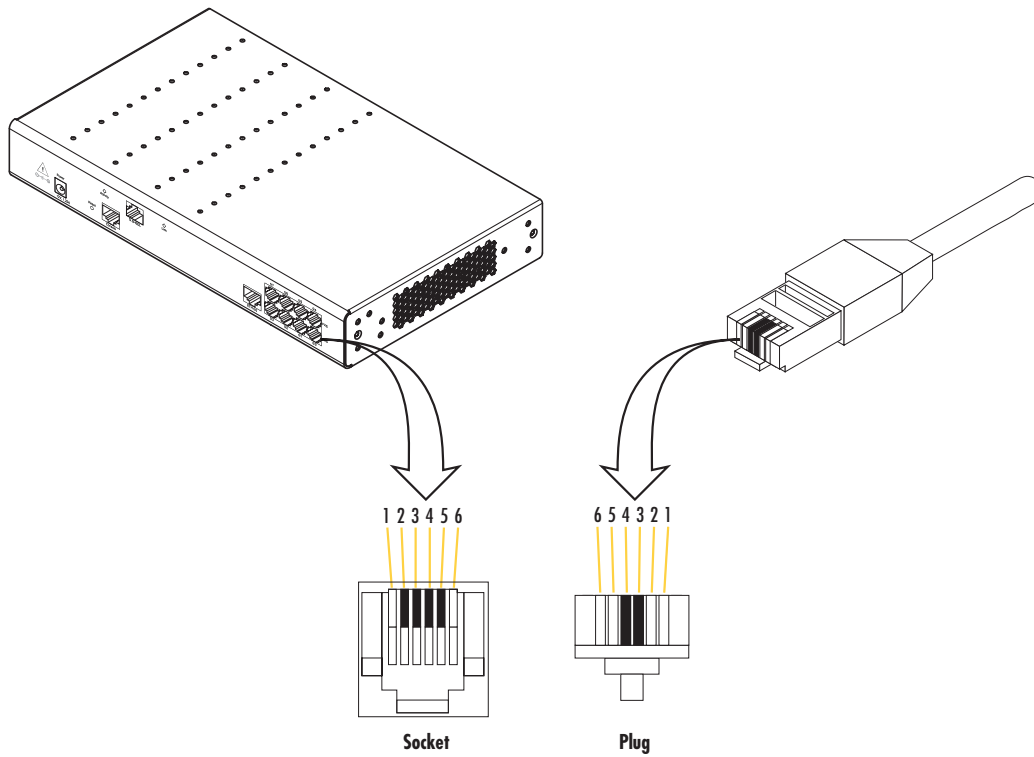

Figure 6. RJ-11 pinout diagram

Table 7. RJ-11 socket

| Pin | Signal |
|-----|----------|
| 3 | Ring (-) |
| 4 | Tip (+) |

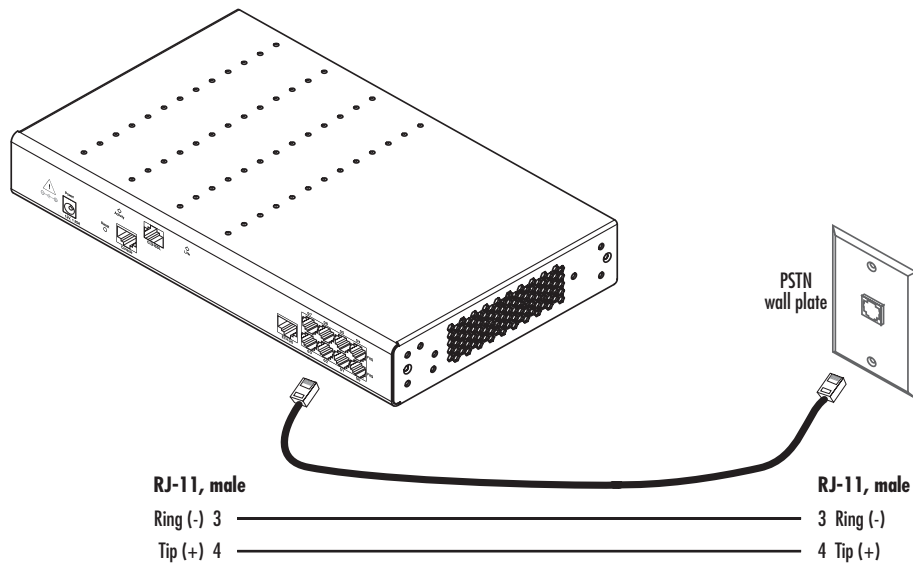

Figure 7. Analog FXO connection

Installing the Ethernet cable

The SmartNode 4830 DSL Series has automatic MDX (auto-cross-over) detection and configuration on the Ethernet port. The Ethernet port can be connected to a host or hub/switch with a straight-through wired cable (see [figure 8](#)). Ethernet devices (10Base-T or 100Base-T) are connected to the SmartNode's Ethernet port (see [table 8](#) for port pin-out listing) via a cable terminated with an RJ-45 plug.

Table 8. Ethernet 10/100Base-T (RJ-45) port pin-outs

| Pin | Signal |
|-----|--------|
| 1 | TX+ |
| 2 | TX- |
| 3 | RX+ |
| 6 | RX- |

Note Pins not listed are not used.

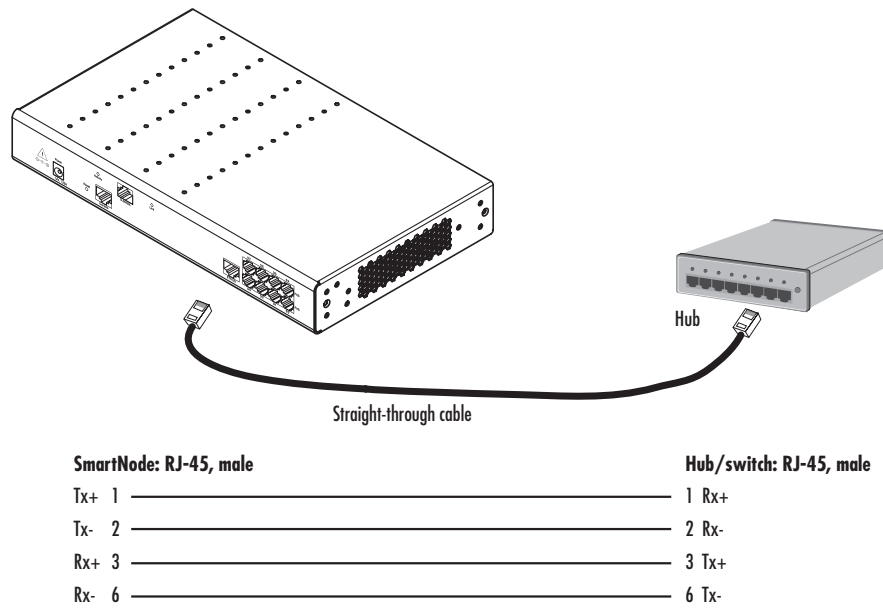

Figure 8. Connecting a SmartNode 4830 DSL Series device to a hub

Installing the DSL cable

The SmartNode Model 4830 comes with an option for a G.SHDSL or ADSL interface. For 2GS models, use a straight-through RJ-45 cable to connect the DSL port. For ADSL and GS models, use a straight-through RJ-11 cable to connect the DSL port. (For a list and description of SmartNode 4830 DSL series model types, refer to [table 3](#) on page 18).

Connecting to external power source

The VoIP IAD comes with an internal or external power supply. This section describes installing the power cord into the VoIP IAD. Do the following:

Note *Do not connect the power cord to the power outlet at this time.*

1. Insert the barrel type connector end of the AC power cord into the external power supply connector (see [figure 9](#)).
2. Insert the female end of the power cord into the internal power supply connector (see [figure 9](#)).

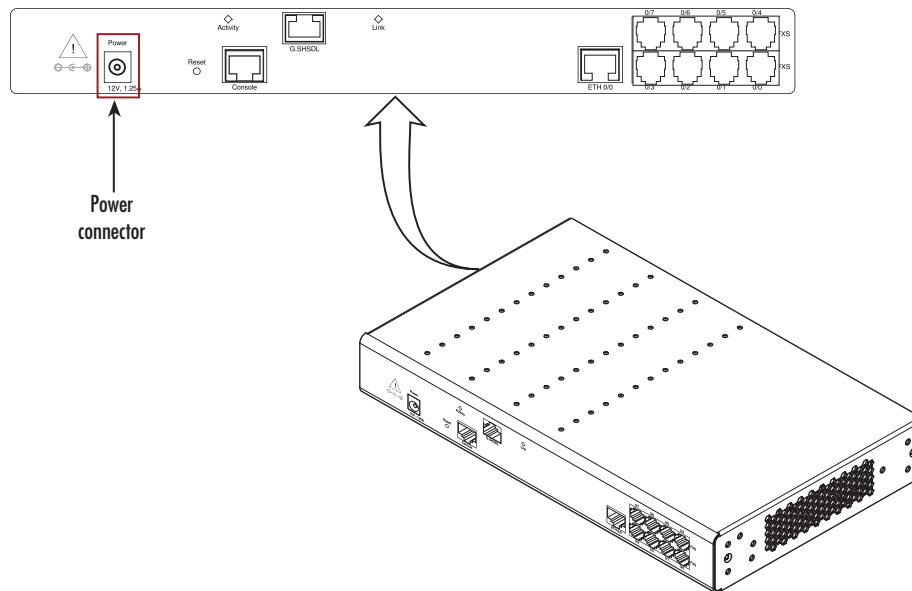

Figure 9. Power connector location on rear panel



The VoIP IAD power supply automatically adjusts to accept an input voltage from 100 to 240 VAC (50/60 Hz).

Verify that the proper voltage is present before plugging the power cord into the receptacle. Failure to do so could result in equipment damage.

3. Verify that the AC power cord included with your VoIP IAD is compatible with local standards. If it is not, refer to chapter 5, “[Contacting Patton for assistance](#)” on page 44 to find out how to replace it with a compatible power cord.
4. Connect the male end of the power cord to an appropriate power outlet.
5. Verify that the green *Power* LED is lit (see [Figure 3](#) on page 19).

Congratulations, you have finished installing the SmartNode VoIP IAD! Now go to chapter 3, “[Getting started with the SmartNode](#)” on page 30.

Chapter 3 **Getting started with the SmartNode**

Chapter contents

- Introduction 31
- 1. Configure IP address 32
 - Power connection and default configuration 32
 - Connect with the PC's serial interface 32
 - Login 33
 - Changing the IP address 33
- 2. Connect the SmartNode to the network 34
- 3. Load configuration 34
- Bootloader 35
 - Start Bootloader 35
 - Start-up with factory configuration 36
 - Load a new application image (SmartWare) via TFTP 36
 - Load a new application image (SmartWare) via the serial link 38
- Additional information 38

Introduction

This chapter leads you through the basic steps to set up a new SmartNode and to download a configuration.

Patton SmartNodes can be used for a wide variety of IP-based network applications. To support and ease the configuration of the SmartNodes configuration, templates for the most important applications are available on the Patton server at www.patton.com/smartnode.

The main steps for setting up a new SmartNode are shown in figure 10.

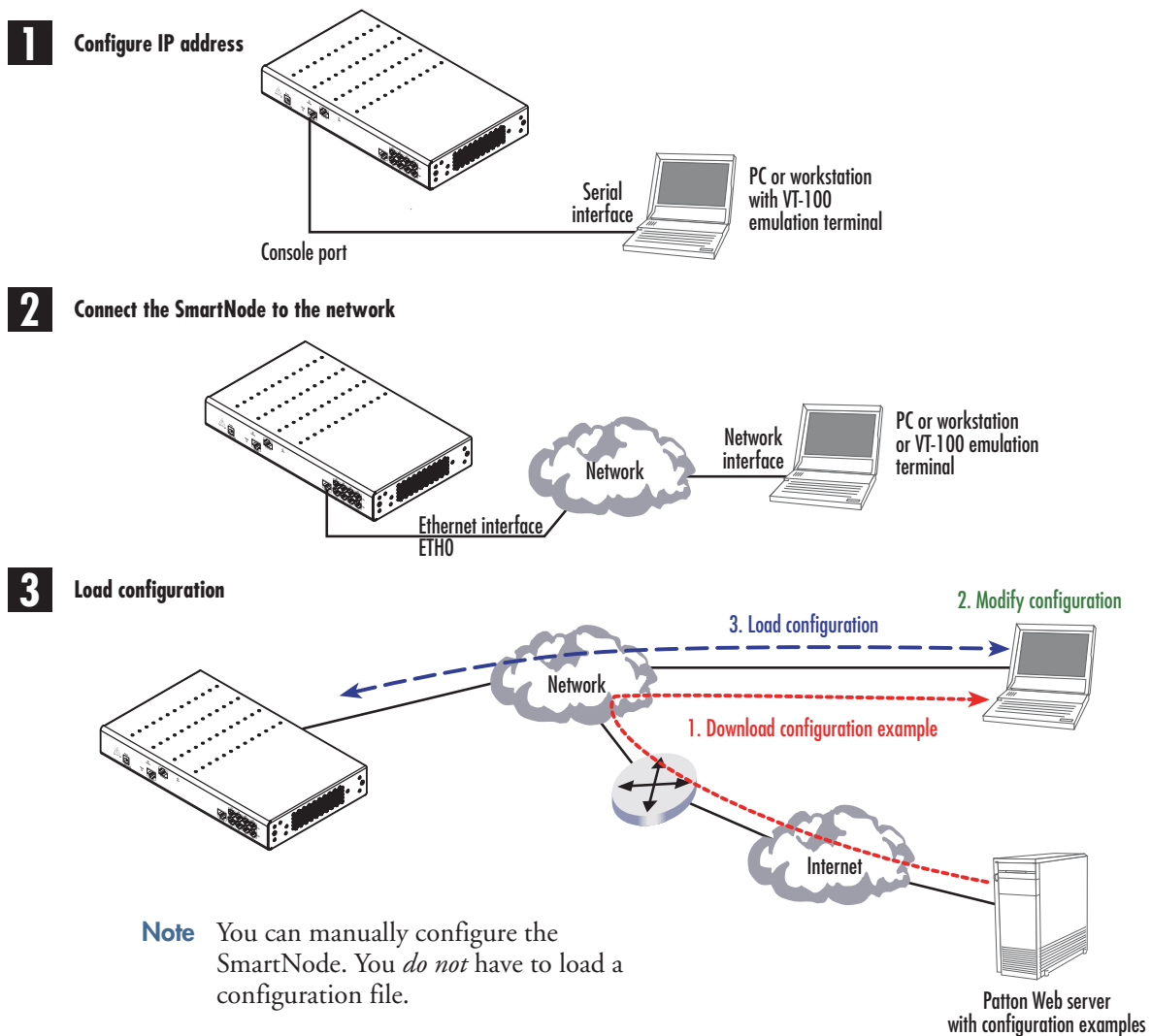

Figure 10. Steps for setting up a new SmartNode

1. Configure IP address

Power connection and default configuration

The factory default configuration for the Ethernet IP addresses and network masks are listed in [table 9](#). Both Ethernet interfaces are activated upon power-up. LAN interface ETH 0/1 (LAN) provides a default DHCP server.

Table 9. Factory default IP address and network mask configuration

| | IP Address | Network Mask |
|------------------------------------|---------------------------|---------------|
| LAN interface Ethernet 1 (ETH 0/0) | 192.168.1.1 | 255.255.255.0 |
| DHCP address range | 192.168.1.10–192.168.1.19 | 255.255.255.0 |

The Ethernet interface is activated upon power-up.

If these addresses match with those of your network, go to section “[2. Connect the SmartNode to the network](#)” on page 34. Otherwise, refer to the following sections to change the addresses and network masks.

Connect with the PC's serial interface

The *Console* port is wired as an EIA-561, RS-232 port. Use the included Model 16F-561 adapter and cable (see [figure 11](#)) between the SmartNode's *Console* port and a PC or workstation's RS-232 serial interface. Activate the terminal emulation program on the PC or workstation that supports the serial interface (e.g. HyperTerm).

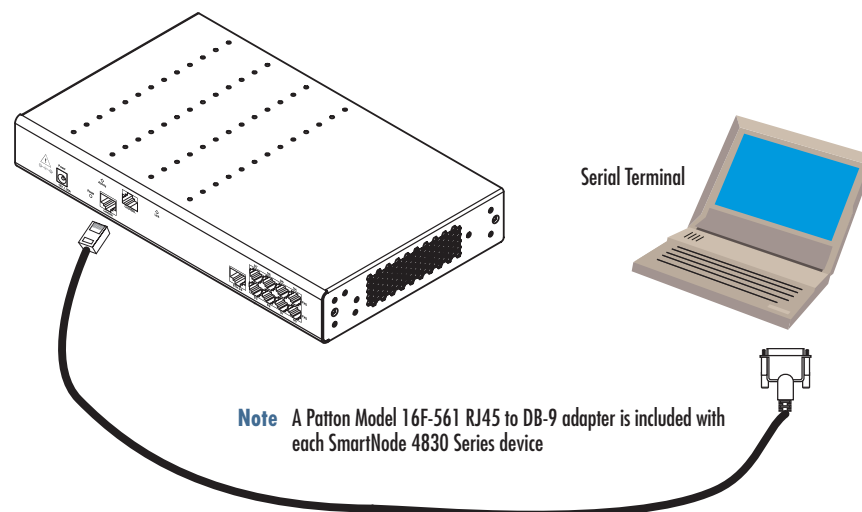

Figure 11. Connecting to the terminal

Terminal emulation program settings:

- 9600 baud
- no parity
- 8 bit
- 1 stop bit
- No flow control

Login

Accessing your SmartNode via the local console port (or via a Telnet session) causes the login screen to display. Type the factory default login: *administrator* and leave the password empty. Press the *Enter* key after the password prompt.

```
login:administrator
password: <Enter>
172.16.40.1>
```

After you have successfully logged in you are in the operator execution mode, indicated by > as command line prompt. With the commands *enable* and *configure* you enter the configuration mode.

```
172.16.40.1>enable
172.16.40.1#configure
172.16.40.1(cfg)#
```

Changing the IP address

Select the context IP mode to configure an IP interface.

```
172.16.40.1(cfg)#context ip product
172.16.40.1(ctx-ip)[product]#
```

Now you can set your IP address and network mask for the interface *eth0*. Within this example a class C network (172.16.1.0/24) is assumed. The IP address in this example is set to *172.16.1.99* (you should set this to an unused IP address on your network).

```
172.16.40.1(ctx-ip)[product]#interface eth0
172.16.40.1(if-ip)[eth0]#ipaddress 172.16.1.99 255.255.255.0
2002-10-29T00:09:40 : LOGINFO    : Link down on interface eth0.
2002-10-29T00:09:40 : LOGINFO    : Link up on interface eth0.
172.16.1.99(if-ip)[eth0]#
```

Copy this modified configuration to your new start-up configuration. Upon the next start-up the system will initialize itself using the modified configuration.

```
172.16.1.99(if-ip)[eth0]#copy running-config startup-config
172.16.1.99(if-ip)[eth0]#
```

The SmartNode can now be connected with your network.

2. Connect the SmartNode to the network

The 4830 Ethernet port is auto-MDX, therefore a straight-through wired cable can be used for host and switch connections (see figure 12).

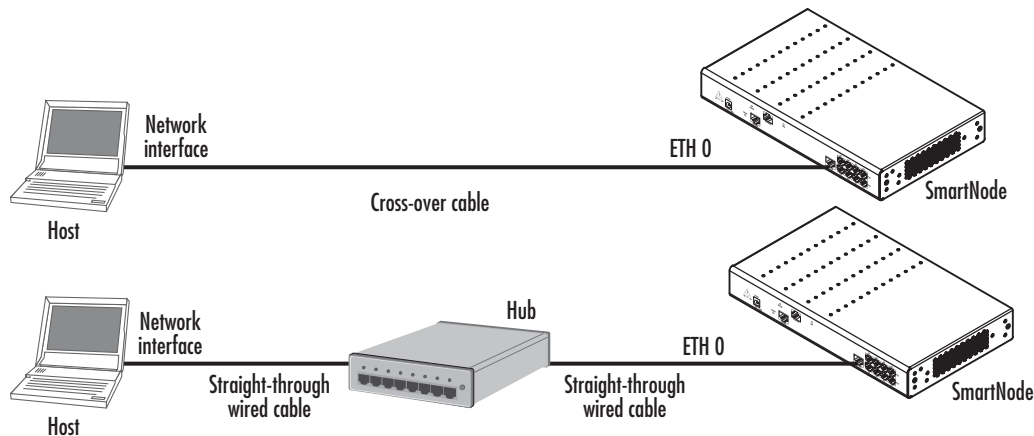

Figure 12. Connecting the SmartNode to the network

You can check the connection with the ping command to another host on the local LAN.

```
172.16.1.99(if-ip)[eth0]#ping <IP Address of the host>
```

Respectively from the host: *ping 172.16.1.99*

Note To ping outside your local LAN, you will need to configure the default gateway.

3. Load configuration

Patton provides a collection of configuration templates on the support page at www.patton.com/smart-node—one of which may be similar enough to your application that you can use it to speed up configuring the SmartNode. Simply download the configuration note that matches your application to your PC. Adapt the configuration as described in the configuration note to your network (remember to modify the IP address) and copy the modified configuration to a TFTP server. The SmartNode can now load its configuration from this server.

Note If your application is unique and not covered by any of Patton's configuration templates, you can manually configure the SmartNode instead of loading a configuration file template. In that case, refer to the *SmartNode Series SmartWare Software Configuration Guide* for information on configuring the SmartNode device.

In this example we assume the TFTP server on the host with the IP address 172.16.1.11 and the configuration named *SN.cfg* in the root directory of the TFTP server.

```
172.16.1.99(if-ip)[eth0]#copy tftp://172.16.1.11/SN.cfg startup-config
Download...100%
172.16.1.99(if-ip)[eth0]#
```

After the SmartNode has been rebooted the new startup configuration will be activated.



When you issue the **reload** command, the SmartNode will ask if you want to copy the running configuration to the startup configuration. Since you just downloaded a configuration file to the startup configuration you must answer this question with **NO**. Otherwise, the downloaded configuration will be overwritten and lost!

```
172.16.1.99(if-ip)[eth0]#reload
Running configuration has been changed.
Do you want to copy the 'running-config' to the 'startup-config'?
Press 'yes' to store, 'no' to drop changes : no
Press 'yes' to restart, 'no' to cancel : yes
The system is going down
```

Bootloader

The bootloader ensures that basic operations, network access, and downloads are possible in case of interrupted or corrupted application image downloads. It offers console access to the Bootloader and the capability for downloading application images (e.g. SmartWare) via the serial link of the console.

Start Bootloader

To start the Bootloader, power on the SmartNode while pressing the reset button. Open a Telnet session to the SmartNode via one of the Ethernet interfaces, or open a CLI session via the console port (if available on the SmartNode). The login display will appear. Using the credentials admin / patton, log in to the SmartNode. The following prompt will be displayed:

```
RedBoot>
```

Type **help** to display an overview of the available commands.

Start-up with factory configuration

| Step | Command | Purpose |
|----------|---|---|
| 1 | RedBoot> fis load | Copies the SmartWare application image from the persistent memory (flash:) to the volatile memory (RAM) from where it will be executed. |
| 2 | RedBoot> go -s factory-config | Starts the SmartWare application telling it to use 'factory-config' as startup configuration. You can also start-up with any other configuration available in the persistent memory (nvram:) by providing its name instead of 'factory-config'. |

Load a new application image (SmartWare) via TFTP

The following procedure downloads the application image (SmartWare) for the mainboard. See the note below on how to download the respective CLI description file.

| Step | Command | Purpose |
|-----------------------------|--|--|
| 1 optional | RedBoot> ip_address -l <i>local_ip_address</i> [/mask_len] | Sets the IP address and subnet mask of the Ethernet interface 0/0 which shall be used to receive the new application image. <i>mask_len</i> is the length of the network address (or the number of 1's within the subnet mask). See Note below. |
| 2 optional | RedBoot> ip_address -g <i>gateway</i> | Sets the IP address of the default gateway. |
| 3 optional | RedBoot> ping -h <i>tftp-server_ip_address</i> | Tests the connectivity to the TFTP server. |
| 4 | RedBoot> load -r -v -h <i>host -b</i> <i>base_address file_name</i> | Downloads an application image into the volatile memory (RAM) from where the SmartNode could directly execute it. <i>host</i> : IP address of the TFTP server <i>base_address</i> : memory location where to store the application image. Use the default address 0x1800100 <i>file_name</i> : path and name of the file on the TFTP server. Note: use the image file that contains the whole application, not the image parts. |
| 5 | RedBoot> fis delete -n 1 | Deletes the first application image. Reply with 'y' to the confirmation request. |
| 6 | RedBoot> fis create | Stores the downloaded application image to the permanent memory (flash:). Reply with 'y' to the confirmation request. |
| 7 | RedBoot> fis list -l | Checks whether the image has been successfully stored, whether it is the desired Release and Build, and whether it is valid. |

| Step | Command | Purpose |
|------|-------------|--|
| 8 | RedBoot> go | Starts the application image that was downloaded into the volatile memory (RAM). |

Note With the Bootloader, only the Ethernet interface 0/0 is available. The Bootloader applies the IP address, subnet mask, and default gateway that were last configured by the Bootloader itself or by another application (e.g. SmartWare). If an application configured the Ethernet interface 0/0 to use DHCP, the Bootloader will also use DHCP to learn the interface configuration. It can receive and apply the IP address, subnet mask, default gateway, and default (TFTP) server (transmitted as basic DHCP information 'Next server IP address').

Note This procedure does not download the respective CLI description file. Download it after starting up SmartWare with the following command:
copy tftp://<tftp_server_address>/<server path>/b1 flash:

Example: Downloading and storing a new application image (SmartWare)

```
RedBoot> ip -l 172.16.40.98/19
RedBoot> ip -g 172.16.32.1
RedBoot> ping -h 172.16.32.100
Network PING - from 172.16.40.98 to 172.16.32.100
.....PING - received 10 of 10 expected

RedBoot> load -r -v -h 172.16.32.100 -b 0x1800100 /Sn4xxx/image.bin
Using default protocol (TFTP)
-
Raw file loaded 0x01800100-0x0199ca6b, 1689964 bytes, assumed entry at 0x01800100

RedBoot> fis delete -n 1
Delete image 1 - continue (y/n)? y
... Erase from 0x60030000-0x601cc974: .....
```

```
RedBoot> fis create
Use address 0x01800100, size 1684402 ? - continue (y/n)? y
... Erase from 0x60030000-0x601cb3ba: .....
```

```
... Program from 0x00011eec-0x00011ef4 at 0x60030000: .
... Program from 0x01800100-0x0199b4b2 at 0x60030008: .....
... Program from 0x00011eec-0x00011ef4 at 0x60030000: .
Image successfully written to flash
```

```
RedBoot> fis list -l
Id Address      Length  State      Description
  Entry        Load Addr
-----
1  0x60030000 1693438 valid      SmartWare R2.10 BUILD28015
   0x01800100 0x01800100 V2.10

RedBoot> go
Starting 'SmartWare R2.10 BUILD28015' at 0x01800100 via 0x01800100
```

Load a new application image (SmartWare) via the serial link

The Bootloader supports the 'X-Modem' and 'Y-Modem' protocols to download application images via the serial link of the console. Do the following to initiate the download:

| Step | Command | Purpose |
|----------|--|---|
| 1 | RedBoot> load -r -v -m { xmodem ymodem } -b base_address | Downloads an application image into the volatile memory (RAM) from where the SmartNode could directly execute it. 'xmodem' or 'ymodem': Specify the protocol to be used, X-Modem or Y-Modem <i>base_address</i> : memory location where to store the application image. Use the default address 0x1800100 Execute the above RedBoot command first, then start the transfer from the terminal program with the command 'Send file via X-Modem' (or similar). |
| 5 | RedBoot> fis delete -n 1 | Deletes the first application image. Reply with 'y' to the confirmation request. |
| 6 | RedBoot> fis create | Stores the downloaded application image to the permanent memory (flash:). Reply with 'y' to the confirmation request. |
| 7 | RedBoot> fis list -l | Checks whether the image has been successfully stored, whether it is the desired Release and Build, and whether it is valid. |
| 8 | RedBoot> go | Starts the application image that was downloaded to the volatile memory (RAM). |

Note This type of download takes about **25 minutes** since it uses a serial link at only 9600 bps.

Additional information

For detailed information about configuring and operating guidance, set up procedures, and troubleshooting, refer to the *Software Configuration Guide* on the Patton website at www.patton.com.

Chapter 4 **DSL Basic Configuration**

Chapter contents

| | |
|---|----|
| Introduction..... | 40 |
| Line Setup | 40 |
| Configuring PPPoE..... | 40 |
| Configuration Summary..... | 41 |
| Setting up permanent virtual circuits (PVC)..... | 42 |
| Using PVC channels in bridged Ethernet mode | 42 |
| Using PVC channels with PPPoE | 42 |
| Diagnostics | 43 |
| Troubleshooting DSL Connections..... | 43 |

Introduction

The SN4830 model has a built-in G.SHDSL or ADSL modem. The modem appears in the configuration as "port dsl 0 0" mode.

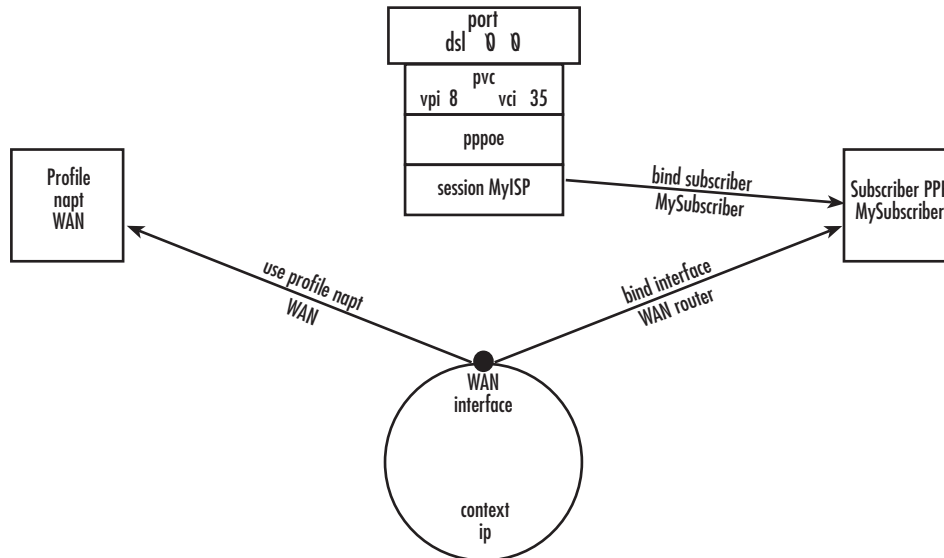

Figure 13. Configuring the G.SHDSL card for PPPoE



The Modem setup uses IP messages within its own subnet: 192.0.2.0/24. SmartNodes with built-in modems cannot use this subnet in any other way.

Note For information about the specifications of the G.SHDSL daughter card, see Appendix B, “Specifications” on page 51.

Line Setup

There is no line modulation setting. The modems automatically adapt to the bit rate and modulation used. The status LED on the back of the device is blinking while the modem attempts to connect and lit when the link is established. If the modem keeps blinking, check the cabling,

Configuring PPPoE

Figure 13 explains how to configure PPPoE on the SmartNode’s built-in G.SHDSL card. To configure the DSL port for PPPoE, first you need to log in to the SmartNode via the CLI and enter configuration mode.

```
login: administrator
password: <enter>
SN4xxx>enable
SN4xxx>#configure
```

Next, you will need to create a WAN profile, create a WAN interface, and create a subscriber. Then, you can configure the DSL port (port dsl 0 0) for PPPoE.

Follow this example:

```
profile napt WAN

context ip router
  interface WAN
    ipaddress unnumbered
    point-to-point
    use profile napt WAN
    tcp adjust-mss rx mtu
    tcp adjust-mss tx mtu

subscriber ppp MySubscriber
  dial out
  authentication chap
  identification outbound <username> password <password>
  bind interface WAN router

port dsl 0 0
  pvc vpi 8 vci 35
  pppoe
    session MyISP
    bind subscriber MySubscriber
    no shutdown
```

The line - `use profile napt WAN` - defines that the NAPT profile *<profile>* will be used on the ip interface *<name>*. For PPPoE, you will only use outbound for identification. You will want to use authentication, which is why you bind to a subscriber. You can use authentication chap or authentication pap. The line - `bind subscriber MySubscriber` - binds the PPPoE session to the PPP subscriber, in case authentication is required. If you do not use authentication, then you will not have a subscriber and you will bind directly to the interface.

Configuration Summary

The modems offer multiple bridged Ethernet connections through logical channels within the DSL link. A logical connection is called a Permanent Virtual Circuit (PVC) and is identified by a VPI/VCI number pair. Consult your provider's configuration instructions for connections used on your DSL link. You define those PVCs inside "port dsl 0 0":

```
port dsl 0 0
  pvc vpi 8 vci 35
```

In the mode "pvc", you define what to do with the bridged Ethernet connection it offers:

- Bind one or more IP interfaces when your providers uses fixed ip addresses or DHCP in the network
- Enter PPPoE mode and define a PPP session if the provider is using PPPoE.

Note PPPoA is not supported.

Setting up permanent virtual circuits (PVC)

The modems currently available are using ATM to multiplex traffic over the DSL framing connection. ATM allows you to have separate logical connections running in parallel. Those connections are called permanent virtual circuits (PVC). All permanent virtual circuits use AAL5 framing.

Table 10. PVC Commands

| | Command | Purpose |
|--------|--|--|
| Step 1 | node(prt-dsl)[0/0]# [no] pvc vpi 8 vci 35 | Creates PVC 8/35 and enters configuration mode for this PVC. The "no"-variant deletes the PVC configuration. |
| Step 2 | node(pvc)[8/35]# encapsulation {llc vc} | Sets the encapsulation to be used. Optionally select either LLC encapsulation or VC multiplexing for this PVC. Default: llc |

Using PVC channels in bridged Ethernet mode

The PVC offers a bridged Ethernet connection as specified in RFC1483, which can be used as an IP link e.g. with DHCP to assign the address, DNS server, and default gateway. To do this, you bind an IP interface to the PVC like it would be done to a normal Ethernet port.

Table 11. PVC channels in bridged Ethernet mode

| | Command | Purpose |
|--------|--|---|
| Step 1 | node(pvc)[vpi/vci]# [no] bind interface <if-name> | Associates an IP interface configuration with this PVC. |

Using PVC channels with PPPoE

The RFC1483 bridged Ethernet connection can also be used for PPPoE. To do this, you enter PPPoE mode within the PVC mode. All PPPoE commands apply as if the PVC was a regular Ethernet port.

Table 12. PVC channels in PPPoE mode

| | Command | Purpose |
|--------|---|---|
| Step 1 | node(pvc)[vpi/vci]# pppoe | Enters PPPoE configuration mode for this PVC. |
| Step 2 | node(pppoe)# session <name> | Defines a PPPoE session. |
| Step 3 | node(session)[<name>]# bind subscriber <subscriber-name> | Links the session to a subscriber definition. |
| Step 4 | node(session)[<name>]# no shutdown | Enables the PPPoE session |

Note The bridged PVC connections are internally mapped to VLANs on a virtual Ethernet port 0/2. You will therefore see references to this third Ethernet port when displaying PPPoE status information or debug logs.

Diagnostics

Table 13. Diagnostics commands

| | Command | Purpose |
|--------|-------------------------------------|--|
| Step 1 | node> show dsl type | Displays the type of modem installed. |
| Step 2 | node> show dsl line-state | Displays information about the state of the DSL link. |
| Step 3 | node> show dsl version | Display firmware version information for the modem. |
| Step 4 | node# debug dsl-setup | Lists the configuration interactions between the gateway and the modem module. |

Troubleshooting DSL Connections

Link State:

- Verify that the DSL link is established (status LED is continuously on)

PPPoE access:

- Check if "show pppoe detail 3" shows "State: opened". This indicates that the PVC is valid and that you reached a PPPoE server through it.
- Check if "show ppp networks detail 3" shows "State: opened" for both the "LCP" and the "CHAP" section. If LCP is not working, there is probably no compatible authentication protocol configured. Make sure "authentication chap" and "authentication pap" are included in the subscriber setup. If only CHAP failed there may be an error with the username or password.
- Run the "debug" command: **node# debug dsl-setup** (See [table 13](#) above).

Chapter 5 **Contacting Patton for assistance**

Chapter contents

- Introduction.....45
- Contact information.....45
 - Patton support headquarters in the USA45
 - Alternate Patton support for Europe, Middle East, and Africa (EMEA)45
- Warranty Service and Returned Merchandise Authorizations (RMAs).....45
 - Warranty coverage45
 - Out-of-warranty service46
 - Returns for credit46
 - Return for credit policy46
 - RMA numbers46
 - Shipping instructions46

Introduction

This chapter contains the following information:

- “Contact information”—describes how to contact Patton technical support for assistance.
- “Warranty Service and Returned Merchandise Authorizations (RMAs)” —contains information about the RAS warranty and obtaining a return merchandise authorization (RMA).

Contact information

Patton Electronics offers a wide array of free technical services. If you have questions about any of our other products we recommend you begin your search for answers by using our technical knowledge base. Here, we have gathered together many of the more commonly asked questions and compiled them into a searchable database to help you quickly solve your problems:

Patton support headquarters in the USA

- Online support: Available at **www.patton.com**
- E-mail support: E-mail sent to **support@patton.com** will be answered within 1 business day
- Telephone support: Standard telephone support is available five days a week—from **8:00 am to 5:00 pm EST (1300 to 2200 UTC/GMT)**—by calling **+1 (301) 975-1007**
- Support via VoIP: Contact Patton free of charge by using a VoIP ISP phone to call **sip:support@patton.com**
- Fax: **+1 (253) 663-5693**

Alternate Patton support for Europe, Middle East, and Africa (EMEA)

- Online support: Available at **www.patton-inalp.com**
- E-mail support: E-mail sent to **support@patton-inalp.com** will be answered within 1 business day
- Telephone support: Standard telephone support is available five days a week—from **8:00 am to 5:00 pm CET (0900 to 1800 UTC/GMT)**—by calling **+41 (0)31 985 25 55**
- Fax: **+41 (0)31 985 25 26**

Warranty Service and Returned Merchandise Authorizations (RMAs)

Patton Electronics is an ISO-9001 certified manufacturer and our products are carefully tested before shipment. All of our products are backed by a comprehensive warranty program.

Note If you purchased your equipment from a Patton Electronics reseller, ask your reseller how you should proceed with warranty service. It is often more convenient for you to work with your local reseller to obtain a replacement. Patton services our products no matter how you acquired them.

Warranty coverage

Our products are under warranty to be free from defects, and we will, at our option, repair or replace the product should it fail within one year from the first date of shipment. Our warranty is limited to defects in work-

manship or materials, and does not cover customer damage, lightning or power surge damage, abuse, or unauthorized modification.

Out-of-warranty service

Patton services what we sell, no matter how you acquired it, including malfunctioning products that are no longer under warranty. Our products have a flat fee for repairs. Units damaged by lightning or other catastrophes may require replacement.

Returns for credit

Customer satisfaction is important to us, therefore any product may be returned with authorization within 30 days from the shipment date for a full credit of the purchase price. If you have ordered the wrong equipment or you are dissatisfied in any way, please contact us to request an RMA number to accept your return. Patton is not responsible for equipment returned without a Return Authorization.

Return for credit policy

- Less than 30 days: No Charge. Your credit will be issued upon receipt and inspection of the equipment.
- 30 to 60 days: We will add a 20% restocking charge (crediting your account with 80% of the purchase price).
- Over 60 days: Products will be accepted for repairs only.

RMA numbers

RMA numbers are required for all product returns. You can obtain an RMA by doing one of the following:

- Completing a request on the RMA Request page in the *Support* section at **www.patton.com**
- By calling **+1 (301) 975-1007** and speaking to a Technical Support Engineer
- By sending an e-mail to **returns@patton.com**

All returned units must have the RMA number clearly visible on the outside of the shipping container. Please use the original packing material that the device came in or pack the unit securely to avoid damage during shipping.

Shipping instructions

The RMA number should be clearly visible on the address label. Our shipping address is as follows:

Patton Electronics Company

RMA#: xxxx

7622 Rickenbacker Dr.

Gaithersburg, MD 20879-4773 USA

Patton will ship the equipment back to you in the same manner you ship it to us. Patton will pay the return shipping costs.

Appendix A **Compliance information**

Chapter contents

| | |
|--|----|
| Compliance | 48 |
| EMC compliance: | 48 |
| Safety compliance: | 48 |
| PSTN regulatory compliance: | 48 |
| Radio and TV Interference (FCC Part 15) | 48 |
| FCC Part 68 (ACTA) Statement (FXO ports) | 49 |
| Industry Canada Notice (FXO ports) | 49 |
| CE Notice | 50 |
| Authorized European Representative | 50 |

Compliance

EMC compliance:

- FCC Part 15, Class A
- EN55022, Class A
- EN55024

Safety compliance:

- UL60950-1/CSA C22.2 No. 60950-1
- AS/NZS 60950-1
- IEC 60950-1
- EN60950-1

PSTN regulatory compliance:

- FCC Part 68
- CS-03
- TBR 21 (JO Models)
- TBR 12 & 13 (E1)
- AS/ACIF S002 (JO Models)
- AS/ACIF S003 (JO & JS Models)
- AS/ACIF S016 (E1)
- AS/ACIF S043 (G.SHDSL & ADSL Card)

Radio and TV Interference (FCC Part 15)

The SmartNode product generates and uses radio frequency energy, and if not installed and used properly—that is, in strict accordance with the manufacturer’s instructions—may cause interference to radio and television reception. The SmartNode product have been tested and found to comply with the limits for a Class A computing device in accordance with specifications in Subpart B of Part 15 of FCC rules, which are designed to provide reasonable protection from such interference in a commercial installation. However, there is no guarantee that interference will not occur in a particular installation. If the SmartNode product does cause interference to radio or television reception, which can be determined by disconnecting the unit, the user is encouraged to try to correct the interference by one or more of the following measures: moving the computing equipment away from the receiver, re-orienting the receiving antenna and/or plugging the receiving equipment into a different AC outlet (such that the computing equipment and receiver are on different branches).



Disconnect all power before servicing.



The SmartNode product contains no user serviceable parts.



The mains outlet that is utilized to power the equipment must be within 1 foot (3 meters) of the device and shall be easily accessible.

FCC Part 68 (ACTA) Statement (FXO ports)

This equipment complies with Part 68 of FCC rules and the requirements adopted by ACTA. On the bottom side of this equipment is a label that contains—among other information—a product identifier in the format *US: AAAEQ##TXXXX*. If requested, this number must be provided to the telephone company.

The method used to connect this equipment to the premises wiring and telephone network must comply with the applicable FCC Part 68 rules and requirements adopted by the ACTA.

If this equipment causes harm to the telephone network, the telephone company will notify you in advance that temporary discontinuance of service may be required. But if advance notice isn't practical, the telephone company will notify the customer as soon as possible. Also, you will be advised of your right to file a complaint with the FCC if you believe it is necessary.

The telephone company may make changes in its facilities, equipment, operations or procedures that could affect the operation of the equipment. If this happens the telephone company will provide advance notice in order for you to make necessary modifications to maintain uninterrupted service.

If trouble is experienced with this equipment, for repair or warranty information, please contact our company. If the equipment is causing harm to the telephone network, the telephone company may request that you disconnect the equipment until the problem is resolved.

Connection to party line service is subject to state tariffs. Contact the state public utility commission, public service commission or corporation commission for information.

Industry Canada Notice (FXO ports)

This equipment meets the applicable Industry Canada Terminal Equipment Technical Specifications. This is confirmed by the registration number. The abbreviation, *IC*, before the registration number signifies that registration was performed based on a Declaration of Conformity indicating that Industry Canada technical specifications were met. It does not imply that Industry Canada approved the equipment.

This Declaration of Conformity means that the equipment meets certain telecommunications network protective, operational and safety requirements. The Department does not guarantee the equipment will operate to the user's satisfaction. Before installing this equipment, users should ensure that it is permissible to be con-

nected to the facilities of the local telecommunications company. The equipment must also be installed using an acceptable method of connection. In some cases, the company's inside wiring associated with a single line individual service may be extended by means of a certified connector assembly (telephone extension cord). The customer should be aware that compliance with the above condition may not prevent degradation of service in some situations. Repairs to some certified equipment should be made by an authorized maintenance facility designated by the supplier. Any repairs or alterations made by the user to this equipment, or equipment malfunctions, may give the telecommunications company cause to request the user to disconnect the equipment. Users should ensure for their own protection that the ground connections of the power utility, telephone lines and internal metallic water pipe system, are connected together. This protection may be particularly important in rural areas.

CE Notice

This equipment conforms to the requirements of Council Directive 1999/5/EC on the approximation of the laws of the member states relating to Radio and Telecommunication Terminal Equipment and the mutual recognition of their conformity.

The safety advice in the documentation accompanying this product shall be obeyed. the conformity to the above directive is indicated by the CE sign on the device.

Authorized European Representative

D R M Green

European Compliance Services Limited.

Oakdene House, Oak Road

Watchfield,

Swindon, Wilts SN6 8TD, UK

Appendix B **Specifications**

Chapter contents

| | |
|---|----|
| DSP..... | 52 |
| Voice connectivity | 52 |
| Ethernet interface | 52 |
| ADSL Daughter Card (if applicable) | 52 |
| G.SHDSL Daughter Card (if applicable)..... | 53 |
| PPP and Frame-Relay support | 53 |
| Voice processing (signaling dependent) | 54 |
| Fax and modem support..... | 54 |
| Voice signaling | 54 |
| Voice routing—session product..... | 55 |
| IP services..... | 55 |
| Management | 55 |
| Operating environment | 56 |
| Operating temperature | 56 |
| Operating humidity | 56 |
| System | 56 |
| Dimensions | 56 |
| Weight and power dissipation | 56 |
| Power supply | 56 |
| Identification of the SmartNode devices via SNMP..... | 57 |

DSP

One or two 4-channel DSPs

Voice connectivity

2-wire Loopstart, RJ-11/12

Short haul loop 1.1 km @3REN

EuroPOTS (ETSI EG201 188)

Programmable AC impedance, feeding, and ring voltage; On-Hook Voltage 48VDC

Caller-ID Type-1FSK and ITU V.23/Bell 202 generation

Ethernet interface

One 10/100 Full Duplex/Autosensing Ethernet RJ-45 s

ADSL Daughter Card (if applicable)

ADSL2+ ITU-T G.992.1 Annex A, B, G.992.2 G.dmt, G.lite, G.992.3 Annex L, I, J

8 user configurable PVCs

ATM QoS per PVC (UBR, CBR, VBR-rt)

Supports PPPoE, Routed IP over ATM

G.SHDSL Daughter Card (if applicable)

Table 14. G.SHDSL Daughter Card Specifications

| Factor | Specs |
|--------------------------------------|---|
| DSL | <ul style="list-style-type: none"> • ITU-T G.991.2 (and Amendment 2) • ITU-T G.991.2, Annex A, B, F, G • Upgradable to ITU-T G.shdsl.bis—Annex F and G • G.991.2 2/4 (1/2 pair) operation • G.994.1 (G.hs) (per G.991.2) • ITU-T G.991.2 Section E.9 (TPS-TC for ATM transport) • ITU-T G.991.2 Section E.11 (TPS-TC for PTM transport) |
| DSL Connection | 2GS models: RJ-45 (4-wire) GS models: RJ-11/12 (2-wire) |
| Management | <ul style="list-style-type: none"> • I.610 OAM F4/F5 • Management interfaces: GUI and Telnet • Software upgrade: GUI and TFTP |
| ATM Support | <ul style="list-style-type: none"> • Classical IPoA (RFC 1577/2225) • PPPoE Client (over ATM) (RFC 2516) • IPoA (RFC 2684/1483) • ATM AAL5 encapsulation • Max. 8 PVCs • User selectable VC MUX and LLC MUX (default) • Configurable auto-connection • ATM QoS: UBR (default), CBR, and VBR-rt, VBR-nrt, UBR: per VC queuing • Auto-configuration: TR-037 & ILMI 4.0 |
| Interworking/Interoperability | <ul style="list-style-type: none"> • G.SHDSL Interoperability: <ul style="list-style-type: none"> - Alcatel - NEC - Lucent Anymedia - Lucent Stinger • BRAS Interoperability: <ul style="list-style-type: none"> - Cisco - Redback |

PPP and Frame-Relay support

Frame-Relay (8 PVCs)

RFC1490, FRF.12 fragmentation

LMI, Q.933D, ANSI 617D, Gang of Four

PPP, PAP, CHAP, LCP, IPCP

Voice processing (signaling dependent)

Voice codes:

- G.711 A-Law/ -Law (64 kbps)
- G.726 (ADPCM 40, 32, 24, 16 kbps)
- G.723.1 (5.3 or 6.3 kbps)
- G.729ab (8 kbps)
- Transparent pass through

G.168 echo cancellation

8 parallel voice connections

DTMF detection and generation

Carrier tone detection and generation

Silence suppression and comfort noise

Configurable dejitter buffer

Configurable tones (dial, ringing, busy)

Configurable transmit packet length

RTP/RTCP (RFC 1889)

Fax and modem support

G.711 transparent FAX

Fax over IP (FoIP)

T.38 Fax relay (9.6 k, 14.4 k)

Voice signaling

H.323v4

- RAS, H.225, H.245
- Fast-connect, early H.245
- Gatekeeper autodiscovery
- Alias registration
- Overlap sending
- Empty capability set (call transfer, hold)
- H.323v1 call transfer, hold
- H.323 GW and GK compatible
- H.323 Annex M3

SIP:

- SIPv2 (RFC3261, RFC3263)
- SIP call transfer, redirect, DTMF relay

Voice routing—session product

Local switching; Interface huntgroups

Routing Criteria:

- Interface
- Calling/called party number
- Time of day, day of week, date

Number manipulation functions

- Replace numbers; Add/remove digits
- Multiple remote gateways; PLAR

IP services

IPv4 product; RIPv1, v2 (RFC 1058 and 2453)

Programmable static routes

ICMP redirect (RFC 792); Packet fragmentation

DiffServe/ToS set or queue per header bits

Pocket Policing discards excess traffic

802.1p VLAN tagging

IPSEC AH & ESP Modes* (*Requires license*)

Manual Key; IKE optional

AES/DES/3DES Encryptions* (*Requires license*)

Management

Industry standard CLI with local console (RJ-45, RS-232, 9600 bps, 8, N, 1) and remote Telnet access

TFTP configuration & firmware loading

SNMP v1 agent (MIB II and private MIB)

Built-in diagnostic tools (trace, debug)

Java™ Applet; HPOV Integration with NNM

Operating environment

Operating temperature

32–104°F (0–40°C)

Operating humidity

5–80% (non condensing)

System

CPU Motorola MPC875 operating at 66 MHz

Memory:

- 32 Mbytes SDRAM
- 8 Mbytes Flash

Dimensions

7.3W x 1.6H x 6.1D in. (18.5H x 4.1W x 15.5D cm)

Weight and power dissipation

See [table 15](#).

Table 15. SmartNode weight and maximum power specifications

| SmartNode model | Weight | Maximum power dissipation |
|-----------------|----------------|---------------------------|
| SN4832/JSX/EUI | 30.5 oz./500 g | 7W |
| SN4834/JSX/EUI | 30.5 oz./500 g | 9W |
| SN4836/JSX/EUI | 30.5 oz./500 g | 11W |
| SN4838/JSX/EUI | 30.5 oz./500 g | 13W |

Power supply

External power supply, 100–240 VAC, 50/60 Hz, 200 mA

Identification of the SmartNode devices via SNMP

All SmartNode devices have assigned sysObjectID (.iso.org.dod.internet.mgmt.mib-2.system.sysObjectID) numbers (see [table 16](#)).

Table 16. SmartNode Models and their Unique sysObjectID

| SmartNode Model | SysObjectID |
|-----------------|--|
| SN4834-JS | .iso.org.dod.internet.private.enterprises.patton.products.sn4xxx.1 1.3.6.1.4.1.1768.2.4.5.1 |
| SN4836-JS | .iso.org.dod.internet.private.enterprises.patton.products.sn4xxx.3 1.3.6.1.4.1.1768.2.4.5.3 |
| SN4838-JS | .iso.org.dod.internet.private.enterprises.patton.products.sn4xxx.4 1.3.6.1.4.1.1768.2.4.5.4 |
| SN4834-2JS2JO | .iso.org.dod.internet.private.enterprises.patton.products.sn4xxx.9 1.3.6.1.4.1.1768.2.4.5.9 |
| SN4836-4JS2JO | .iso.org.dod.internet.private.enterprises.patton.products.sn4xxx.10 1.3.6.1.4.1.1768.2.4.5.10 |
| SN4838-4JS4JO | .iso.org.dod.internet.private.enterprises.patton.products.sn4xxx.11 1.3.6.1.4.1.1768.2.4.5.11 |
| SN4832-JO | .iso.org.dod.internet.private.enterprises.patton.products.sn4xxx.15 1.3.6.1.4.1.1768.2.4.5.15 |
| SN4834-JO | .iso.org.dod.internet.private.enterprises.patton.products.sn4xxx.16 1.3.6.1.4.1.1768.2.4.5.16 |

According to [table 16](#), an SNMP get request to *.iso.org.dod.internet.mgmt.mib-2.system.sysObjectID* of a SmartNode 4834-JS device reads out a numeric OID of *1.3.6.1.4.1.1768.2.4.5.1*, which represents a SmartNode 4834 device. The mapping of the sysObjectID to each of the SmartNode model is realized with the SmartNode product identification MIB.



IMPORTANT

The SNMP agent running in SmartWare is SNMP version 1 (SNMPv1) compliant. SNMP version 2 (SNMPv2) and SNMP version 3 (SNMPv3) are not currently supported.

Appendix C **Cabling**

Chapter contents

| | |
|--------------------------------------|----|
| Introduction..... | 59 |
| Serial console..... | 59 |
| Ethernet 10Base-T and 100Base-T..... | 60 |
| Analog FXS..... | 61 |
| Analog FXO..... | 62 |
| DSL..... | 63 |

Introduction

This section provides information on the cables used to connect the SmartNode and the interface cards to the existing network infrastructure and to third party products.

Serial console

The SmartNode can be connected to a serial terminal over its serial console port, as depicted in [figure 14](#).

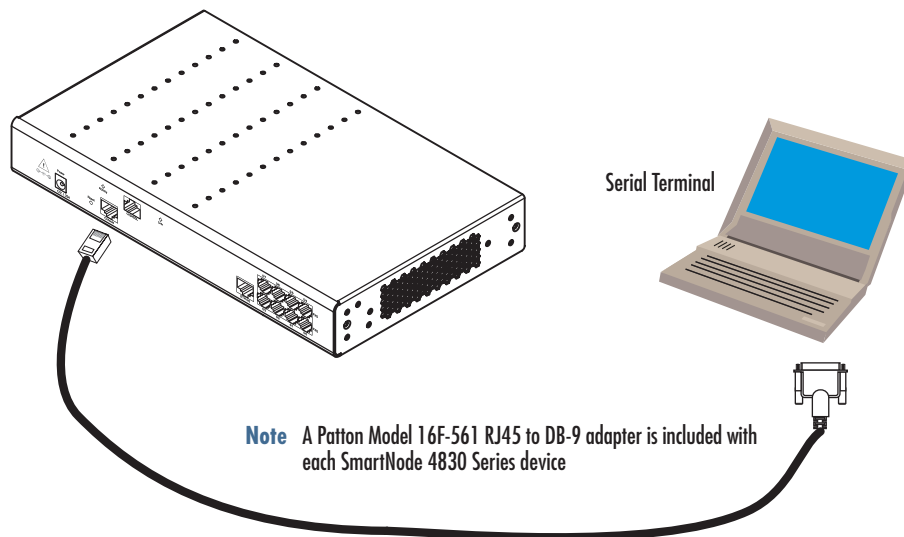

Figure 14. Connecting a serial terminal

Note See section “Console port” on page 65 for console port pin-outs.

Ethernet 10Base-T and 100Base-T

Ethernet devices (10Base-T/100Base-T) are connected to the SmartNode over a cable with an RJ-45 plug. The Ethernet port supports auto-MDI-X, so any standard Ethernet cable will work properly.

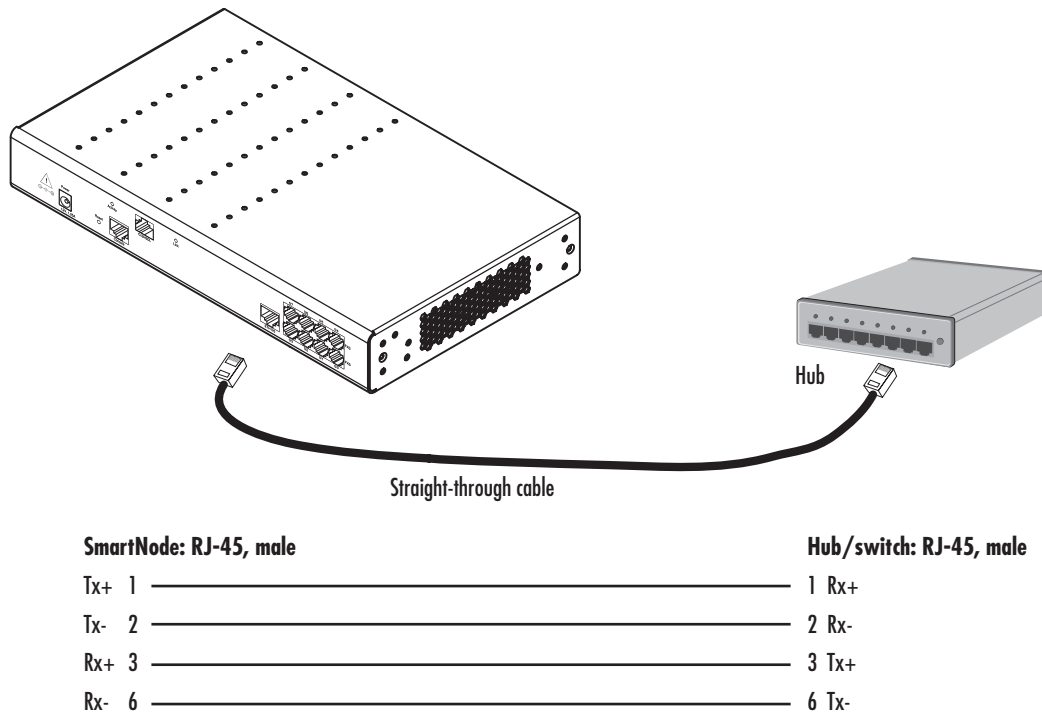

Figure 15. Ethernet straight-through

Analog FXS

Applicable to SmartNodes equipped with FXS ports. The FXS ports are connected to analog terminals (phones, fax machines, answering machines) via cables terminated with RJ-11 connectors (see section “FXS port” on page 66 for details on port pinouts).

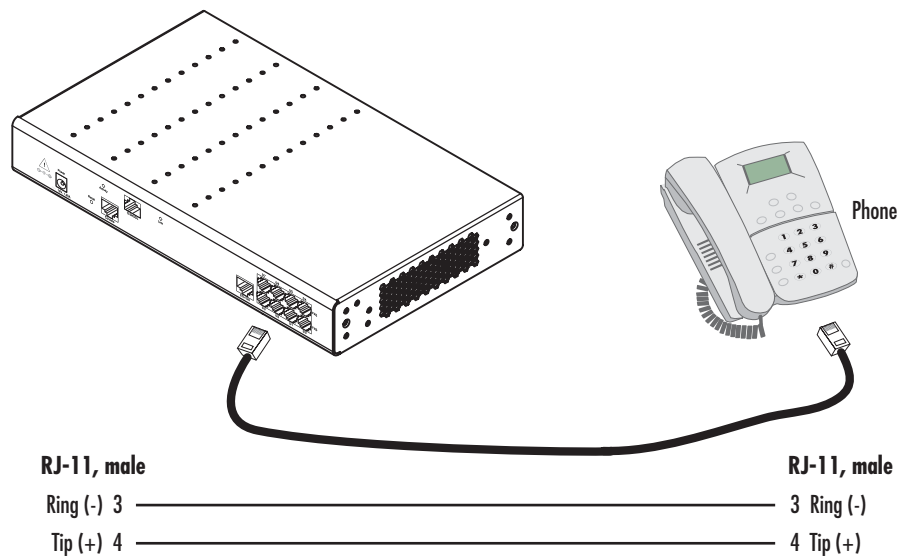

Figure 16. Connecting an FXS device

Analog FXO

Applicable to SmartNodes equipped with FXO ports. The FXO ports are connected to analog phone lines via cables terminated with RJ-11 connectors (see section “FXO port” on page 66 for details on port pinouts).

Note The phone line socket (connector type and pinout) available from the public network vary from country to country. Refer to technical information available from your local operator for additional cabling information.

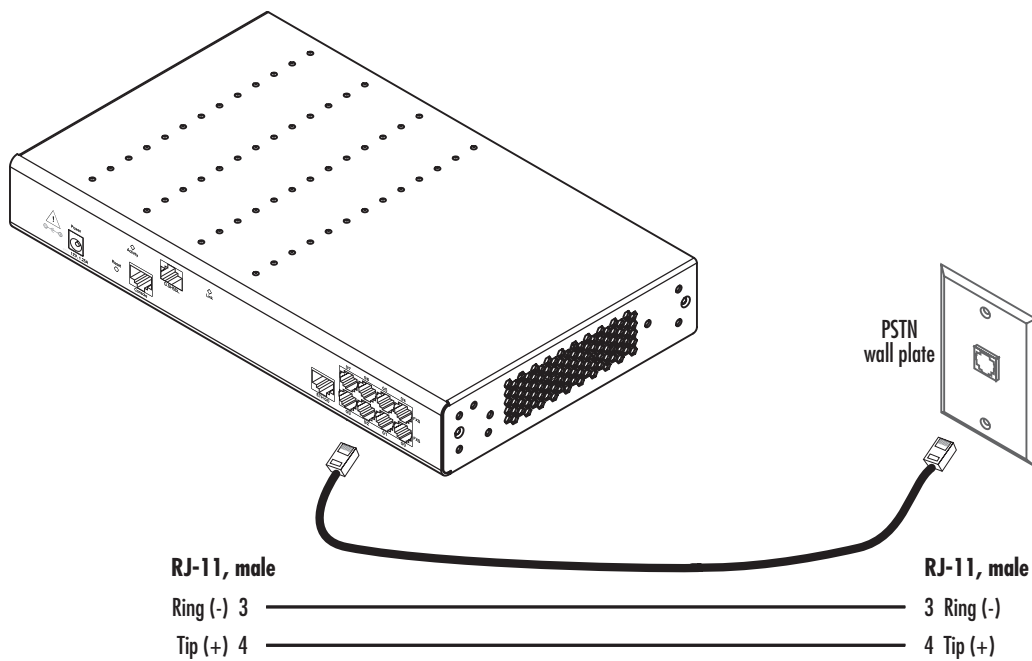

Figure 17. Connecting to an FXO line socket

DSL

The DSL interface connects to the analog or ISDN telecom line coming to your house. Depending on the country and type of installation, a frequency splitter device may be inserted between the phone outlet and the SmartNode, splitting the DSL signal from the phone signal.

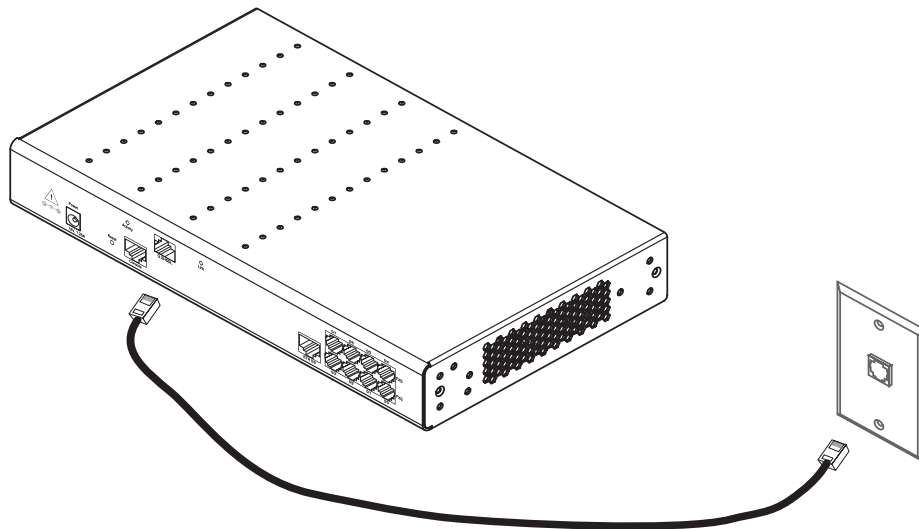

Figure 18. Connecting the DSL cable

Appendix D **Port pin-outs**

Chapter contents

| | |
|--|----|
| Introduction..... | 65 |
| Console port..... | 65 |
| Ethernet 10Base-T and 100Base-T port | 65 |
| FXS port..... | 66 |
| FXO port | 66 |
| ADSL/G.SHDSL port..... | 67 |
| 2GS Models (RJ-45) | 67 |
| ADSL and GS Models (RJ-11) | 67 |

Introduction

This section provides pin-out information for the ports of the SmartNode.

Console port

Configuration settings: 9600 bps, 8 bits, no parity, 1 stop bit, no flow control

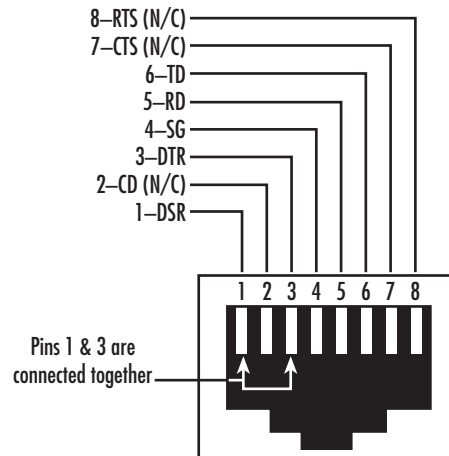

Figure 19. EIA-561 (RJ-45 8-pin) port

Note *N/C* means no internal electrical connection.

Ethernet 10Base-T and 100Base-T port

Table 17. RJ-45 socket

| Pin | Signal |
|-----|--------|
| 1 | TX+ |
| 2 | TX- |
| 3 | RX+ |
| 6 | RX- |

Note Pins not listed are not used.

FXS port

The FXS ports use an RJ-11 connector with 6 positions. The middle two positions, 3 and 4, are used according to [table 18](#).

Table 18. RJ-11 socket

| Pin | Signal |
|-----|----------|
| 3 | Ring (-) |
| 4 | Tip (+) |

Note Pins not listed are not used.

FXO port

The FXO ports use an RJ-11 connector with 6 positions. The middle two positions, 3 and 4, are used according to [table 19](#).

Table 19. RJ-11 socket

| Pin | Signal |
|-----|----------|
| 3 | Ring (-) |
| 4 | Tip (+) |

Note Pins not listed are not used.

ADSL/G.SHDSL port

2GS Models (RJ-45)

Table 20. RJ-45 DSL port

| Pin | Signal |
|-----|--------|
| 3 | Tip 2 |
| 4 | Tip 1 |
| 5 | Ring 1 |
| 6 | Ring 2 |

ADSL and GS Models (RJ-11)

Table 21. RJ-11 DSL port

| Pin | Signal |
|-----|---------------|
| 1 | No connection |
| 2 | Tip 1 |
| 3 | Ring 1 |
| 6 | No connection |

Note Pins not listed are not used.

Appendix E **Installation checklist**

Chapter contents

Introduction.....68

Introduction

This appendix lists the tasks for installing a SmartNode 4830 DSL Series Analog VoIP IAD (see [table 22](#)). Make a copy of this checklist and mark the entries as you complete each task. For each SmartNode 4830 DSL Series IAD, include a copy of the completed checklist in your site log.

Table 22. Installation checklist

| Task | Verified by | Date |
|--|-------------|------|
| Network information available & recorded in site log | | |
| Environmental specifications verified | | |
| Site power voltages verified | | |
| Installation site pre-power check completed | | |
| Required tools available | | |
| Additional equipment available | | |
| All printed documents available | | |
| SmartWare release & build number verified | | |
| Rack, desktop, or wall mounting of chassis completed | | |
| Initial electrical connections established | | |
| ASCII terminal attached to console port | | |
| Cable length limits verified | | |
| Initial configuration performed | | |
| Initial operation verified | | |