

# USER MANUAL

---

## MODEL IM2RC/F-128K Co-Directional Rack Mount Modem Rear Card



**PA PATTON**  
**E Electronics Co.**



*An ISO-9001  
Certified Company*

Part# 07MIM2RC/F128-A  
Doc# 078541UA  
Revised 07/27/99

SALES OFFICE  
(301) 975-1000  
TECHNICAL SUPPORT  
(301) 975-1007  
<http://www.patton.com>

## TABLE OF CONTENTS

<b>SECTION</b>	<b>PAGE</b>
1.0 Warranty Information .....	2
1.1 Radio and TV Interference	
1.2 Service Information	
2.0 General Information .....	4
2.1 Product Features	
2.2 General Product Description	
3.0 Configuration .....	5
3.1 Configuring the IM2RC/F-128K Hardware Switches	
3.2 Connecting the Interface Driver Board	
4.0 Installation .....	9
4.1 The Model 1000R16 Rack Chassis	
4.1.1 The Rack Power Supply	
4.2 Installing the Rear IM2RC/F-128K Card and Front Function Card	
4.3 Making Interface Connections	
4.3.1 Connecting to a G.703 PCM Network Channel	
4.3.2 Connecting the Line Interface	
4.3.3 Two-Wire and Four-Wire Cable Connection via RJ-45	
5.0 Operation .....	14
5.1 Typical Application	
5.2 Operating Instructions	
Appendix A - Specifications .....	15
Appendix B - Cable Recommendations .....	16
Appendix C - Factory Replacement Parts .....	17
Appendix D - 120 Ohm G.703 Interface Pin Assignment .....	18
Appendix E - Line Interface Assignment .....	19

## 1.0 WARRANTY INFORMATION

**Patton Electronics** warrants all Model IM2RC/F-128K components to be free from defects, and will—at our option—repair or replace the product should it fail within one year from the first date of shipment.

This warranty is limited to defects in workmanship or materials, and does not cover customer damage, abuse or unauthorized modification. If this product fails or does not perform as warranted, your sole recourse shall be repair or replacement as described above. Under no condition shall **Patton Electronics** be liable for any damages incurred by the use of this product. These damages include, but are not limited to, the following: lost profits, lost savings and incidental or consequential damages arising from the use of or inability to use this product.

**Patton Electronics** specifically disclaims all other warranties, expressed or implied, and the installation or use of this product shall be deemed an acceptance of these terms by the user.

### 1.1 RADIO AND TV INTERFERENCE

The Model IM2RC/F-128K generates and uses radio frequency energy, and if not installed and used properly—that is, in strict accordance with the manufacturer's instructions—may cause interference to radio and television reception. The Model IM2RC/F-128K has been tested and found to comply with the limits for a Class A computing device in accordance with the specifications in Subpart J of Part 15 of FCC rules, which are designed to provide reasonable protection from such interference in a commercial installation. However, there is no guarantee that interference will not occur in a particular installation. If the Model IM2RC/F-128K does cause interference to radio or television reception, which can be determined by disconnecting the unit, the user is encouraged to try to correct the interference by one or more of the following measures: moving the computing equipment away from the receiver, re-orienting the receiving antenna and/or plugging the receiving equipment into a different AC outlet (such that the computing equipment and receiver are on different branches). In the event the user detects intermittent or continuous product malfunction due to nearby high power transmitting radio frequency equipment, the user is strongly advised to use only data cables with an external outer shield bonded to a metal or metalized connector at both ends. Shielded cables must be used on the network connection to satisfy compliance with the Electromagnetic Compatibility (EMC) directive.

## 1.2 SERVICE

All warranty and non-warranty repairs must be returned freight pre-paid and insured to Patton Electronics. All returns must have a Return Materials Authorization number on the outside of the shipping container. This number may be obtained from Patton Electronics Technical Services at:

Tel: **(301) 975-1007**  
Email: **support@patton.com**  
www: **http://www.patton.com**

**NOTE: Packages received without an RMA number will not be accepted.**

Patton Electronics' technical staff is also available to answer any questions that might arise concerning the installation or use of your Model IM2RC/F-128K. Technical Service hours: **8AM to 5PM EST, Monday through Friday.**

**WARNING!**  This device is not intended to be connected to the public telephone line.

## 2.0 GENERAL INFORMATION

Thank you for your purchase of this Patton Electronics product. This product has been thoroughly inspected and tested and is warranted for One Year parts and labor. If any questions arise during installation or use of this product, please contact Patton Electronics Technical Support at: (301) 975-1007.

### 2.1 FEATURES

- Designed for use with Patton Electronics short range modem access products that receive Patton's Rear Card modules and support 128k synchronous data rates
- 120 ohm RJ-45 Network Termination
- Complies with ITU-T G.823 Jitter Control Specifications
- Supports Clear Channel
- Built-in Transformer Isolation and Surge Protection
- Supports Network or Modem Timing
- Fits in Patton's 2u (3.5") rack chassis and cluster boxes
- Made in the U.S.A.

### 2.2 DESCRIPTION

The Patton Model IM2RC/F-128K is a rack-mountable rear card that allows Patton baseboard modems to connect to modified 128 kbps G.703 devices. With the IM2RC/F-128K you can achieve high speed G.703 network extension, dedicated high speed internet access, remote LAN access,...the possibilities are endless! Supporting 128kbps clear channel, the IM2RC/F-128K can set its own clock or it take clocking from the G.703 network.

The Model IM2RC/F-128K meets baseband modem function cards such as 1094ARC and 1095RC in the mid-plane of Patton's 2U (3.5") rack chassis. G.703 access is accomplished via a 120 Ohm RJ-45 jack. The twisted pair line connections between the baseboard modems (2-W or 4-W) are made with the second RJ-45 jack.

The Model IM2RC/F-128K features on-board transformer isolation and surge protection as well as compliance with ITU-T G.823 Jitter Control Specifications.

### 3.0 CONFIGURATION

This section describes how to configure the IM2RC/F-128K rear card. Please refer to the appropriate function card user manual to configure the function card.

**WARNING!** The IM2RC/F-128K card contains sensitive integrated circuitry. Failure to ground yourself during configuration may result in damage to the IM2RC/F-128K card or the front function card.

#### 3.1 CONFIGURING THE IM2RC/F-128K HARDWARE SWITCHES

The Model IM2RC/F-128K rear card features an eight position DIP switch mounted on the rear of the printed circuit board. Use these switches to configure G.703 operational and timing modes. Figure 1, below shows the position of the DIP switches on the board.

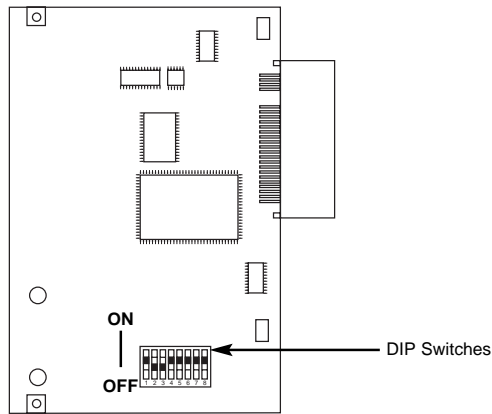

Figure 1. Model IM2RC/F-128K Card Showing DIP Switches

Figure 2 shows the orientation of the DIP switches with respect to the "ON" and "OFF" positions.

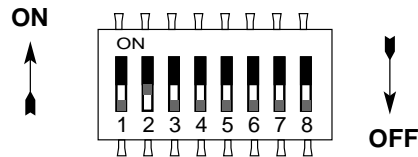

Figure 2. Close up of Configuration switches

SWITCH SUMMARY TABLE		
Position	Function	Factory Default
S1	<i>Reserved for Future Use</i>	Off
S2	Operation Mode	Off Clear Channel
S3	Timing Mode	Off Network Timing
S4	<i>Reserved for Future Use</i>	Off
S5	<i>Reserved for Future Use</i>	Off
S6	G.703 Transmit Octet	Off Injected BPVs
S7	<i>Reserved for Future Use</i>	Off
S8	<i>Reserved for Future Use</i>	Off

**Notice!** The RJ-45 G.703 port of the Model IM2RC/F-128K is intended to connect to telecommunication network voltage (TNV) circuits which may carry dangerous voltages. Therefore the power and network cables must be disconnected prior to switch configuration.

#### Switch S1: *Reserved for Future Use*

Switch S1 is reserved for future use and should remain in the Off position.

#### Switch S2: Operation Mode

Use Switch S2 to set the IM2RC/F-128K for Clear Channel/Unstructured mode.

S2	Setting
Off	Clear Channel/Unstructured Mode ( <b>default</b> )
On	Reserved for Future Use

#### Switches S3 Timing Mode

The setting of Switch S3 determines the source of the system timing. The system timing may be provided by:

1. The G.703 network, or
2. The local function card or remote baseband modem/CSU/DSU (either a rackable function card or stand-alone unit).

Set Switch S3 to "Network" timing to derive timing from the G.703 access port.

Set Switch S3 to "Modem" timing to derive timing from the received line.

You must also set the timing on the NetLink front card. The table below shows the appropriate setting for the IM2RC/F-128 timing modes.

TABLE FOR TIMING CONFIG.	
IM2RC/F-128	NetLink Card
Network	External
Modem	Receive Recover Internal

**Switches S4 and S5: Reserved for Future Use**

Switches S4 and S5 are reserved for future use and should remain in the **Off** position.

**Switch S6: Operation Mode**

In some cases it is necessary to include bi-polar violations in the AMI structure when operating in Clear Channel (128 kbps) mode. This necessity is determined by communications or terminal equipment external to the the IM2RC/F-128K. Use Switch S6 to configure the unit to transmit G.703 data to the network with or without BPVs.

S6	Setting
On	No BPVs
Off	Injected BPVs

**Switches S7 and S8: Reserved for Future Use**

Switch S7 and S8 are reserved for future use and should remain in the Off position.

**3.2 CONNECTING THE INTERFACE DRIVER BOARD**

This package contains an interface driver board that allows you to configure your front function card for G.703 operation. Figure 3 shows the Interface Driver Board connected to a Model 1092ARC front function card (You may also use this product with other Patton rack cards, such as Model 1094ARC and 1095RC).

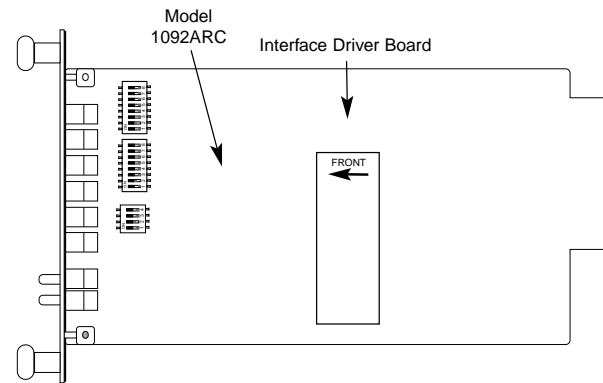

**Figure 3** Model IM2RC/F Driver Board mounted on Model 1092ARC

Follow the instructions below to connect the interface driver board to the front function card:

1. With the function card (such as 1092ARC, shown above) pulled out of the rack or clusterbox chassis, locate the driver board to be replaced on the top of the base unit front card.
2. Lift the old interface board gently off of the PC board.
3. Position the IM2RC/F-128K driver board on top of the function card's pc board with the sockets oriented toward the male pins. Please be sure the label marked **FRONT** ← is pointed toward the front of the function card (toward the LEDs).
4. Push the Interface Driver Board gently onto the socket and re-install the function card into the rack or cluster system.

## 4.0 INSTALLATION

This section describes the functions of the Model 1000R16 rack chassis, tells how to install the rear-mounted Model IM2RC/F-128K card into the chassis, and how to connect to the G.703 PCM network, and to the twisted pair line interface. Please refer to the appropriate function card user manual for further details.

### 4.1 THE MODEL 1000R16 RACK CHASSIS

The Model 1000R16 Rack Chassis (Figure 4, below) has sixteen baseband modem card slots, plus its own power supply. Measuring only 3.5" high, the Model 1000R16 is designed to occupy only 2U in a 19" rack. Sturdy front handles allow the Model 1000R16 to be extracted and transported conveniently.

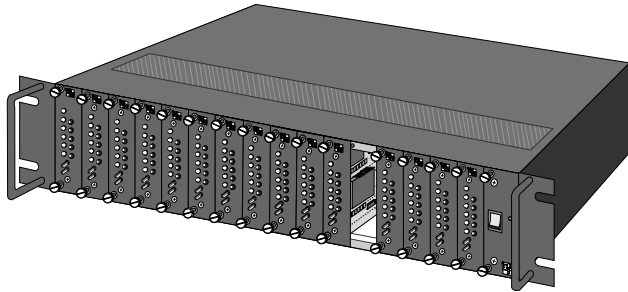

Figure 4: Model 1000R16 Rack Chassis with power supply

#### 4.1.1 The Rack Power Supply

The power supply included in the Model 1000R16 rack uses the same mid-plane architecture as the function cards. The front function card and the power supply slide in from the front, while the rear card and power entry modules slide in from the rear. They plug into one another in the middle of the rack. The front card is then secured by thumb screws and the rear card by conventional metal screws.

**WARNING!** There are no user-serviceable parts in the power supply section. Voltage setting changes and fuse replacement should only be performed by qualified service personnel. Contact Patton Electronics Technical support at (301)975-1007 for more information.

**NOTE:** Please refer to the Model 1000RP Series User Manual *AC and DC Rack Mount Power Supplies* for fuse and power card replacement information.

### 4.2 INSTALLING THE REAR IM2RC/F-128K CARD AND FRONT FUNCTION CARD

The Model IM2RC/F-128K is a rear-mountable G.703 interface card that works with Patton function card access products that support 64k/128k synchronous data rates. The two cards meet inside the rack chassis and plug into each other by way of mating 50 pin card edge connectors. Use the following steps as a guideline for installing each Model IM2RC/F-128K and its function card mate into the rack chassis:

**WARNING!** The IM2RC/F-128K card contains sensitive integrated circuitry. Failure to ground yourself during installation may result in damage to the IM2RC/F-128K card or the front function card.

1. Slide the IM2RC/F-128K rear card into the back of the chassis along the metal rails provided.
2. Secure the IM2RC/F-128K rear card using the metal screws provided.
3. Slide the front function card into the front of the chassis. It should meet the IM2RC/F-128K rear card when it is almost all the way into the chassis.
4. Push the front card *gently* into the card-edge receptacle of the rear card. It should "click" into place.
5. Secure the front card using the thumb screws.

### 4.3 MAKING INTERFACE CONNECTIONS

The Model IM2RC/F-128K is designed to provide access to a 64 kbps co-directional G.703 PCM network. Figure 5 shows the position of the G.703 interface and the line interface of the IM2RC/F-128K. This section describes how to connect the G.703 interface and the line interface.

**Notice!** The G.703 line surge protection on this unit was installed for circuit protection only. By no means does this include the preservation of signal quality during a large surge.

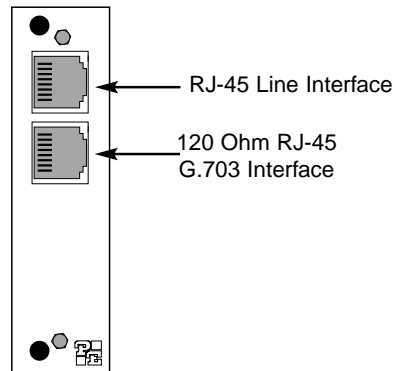

Figure 5: Model IM2RC/F128-K Interface Ports

#### 4.3.1 CONNECTING TO A G.703 PCM NETWORK CHANNEL

The 120 Ohm RJ-45 port on a Model IM2RC/F-128K is pre-wired for direct connection to the G.703 PCM network. Connect the RJ-45 jack provided by your digital service carrier to the 120 Ohm G.703 interface on the Model IM2RC/F-128K using a **straight through** twisted pair cable between 19 and 26 AWG (0.4mm to .9mm, inversely). To be sure you have the right wiring, refer to Figure 6, on the following page.

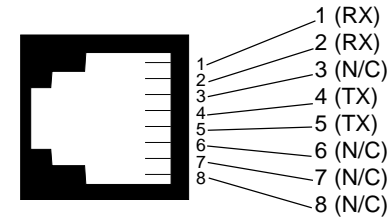

Figure 6: 120 Ohm RJ-45 G.703 Interface

#### 4.3.2 CONNECTING THE LINE INTERFACE

The Model IM2RC/F-128K is to be used with Patton function card access products (i.e. 1092RC, 1092ARC, 1094ARC and 1095RC) that support 128k synchronous data rates. There are two essential requirements for connecting the line interface on Model IM2RC/F-128K:

1. These units work in **pairs**. Both units at the end of the twisted pair must have the proper 2-Wire/4-Wire setting. For instance, if you are operating in 2-Wire mode, both units must be in the 2-Wire setting. Similarly, if you are operating in 4-Wire mode, both units must be in the 4-Wire setting. **NOTE:** Currently only the 1092, 1092A, and 1095 families support 2-Wire Mode.
2. To function properly, the Model IM2RC/F-128K needs one or two **twisted** pairs of metallic wire. The twisted pairs must be **unconditioned**, dry, metallic wire, between 19 (.9mm) and 26 AWG (.4mm) (Appendix B describes cable requirements) . Standard dial-up telephone circuits, or leased circuits that run through signal equalization equipment, or standard, flat modular telephone type cable, are *not acceptable*. Figure 7, below, shows the pin/signal relationships of the Line Interface Port.

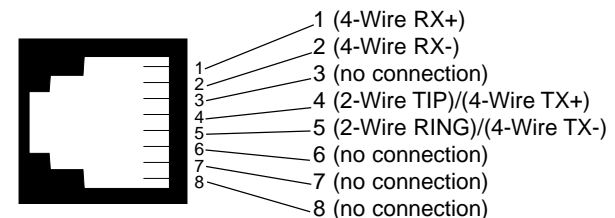

Figure 7: RJ-45 Line Interface

### 4.3.3 Two-Wire and Four-Wire Cable Connection Via RJ-45

1. The Line Interface Port on the Model IM2RC/F-128K's twisted pair interface is polarity insensitive and is wired for a two-wire interface.

2. **Proper 2-Wire Pairing** between the two modems is as follows:

<u>SIGNAL</u>	<u>PIN#</u>	<u>PIN#</u>	<u>SIGNAL</u>
TIP	4-----	4	TIP
RING	5-----	5	RING

3. **Proper 4-Wire Pairing** between the two modems is as follows:

<u>SIGNAL</u>	<u>PIN#</u>	<u>PIN#</u>	<u>SIGNAL</u>
Tx	4-----	3	Rx
Tx	5-----	6	Rx
Rx	3-----	4	Tx
Rx	6-----	5	Tx

**NOTE:** The pin designations shown above are to be used when connecting to another IM2RC/F-128K or other similarly pinned line interface on a Patton rear card. Please review the appropriate function card user manual or stand-alone product user manual to determine the correct pin assignments.

## 5.0 OPERATION

Once the Model IM2RC/F-128K is installed and configured, it should operate transparently. This sections describes a typical application and general operating instructions.

### 5.1 TYPICAL APPLICATION

The Model IM2RC/F-128K allows a remotely connected LAN or high speed application to connect to the 128/G.703 (PCM) network through a pair of Patton baseband modems. Figure 8 (below) shows a typical application of the IM2RC/F-128K.

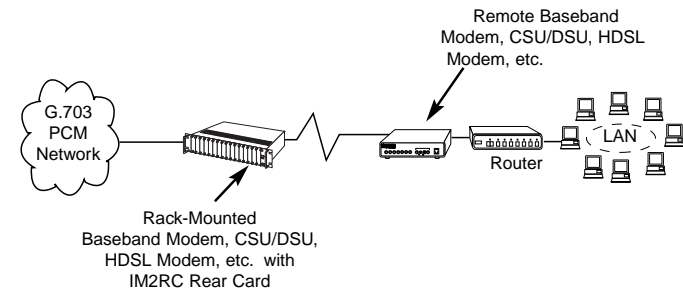

Figure 8: IM2RC/F-128K Typical Application

### 5.2 OPERATING INSTRUCTIONS

In order to operate, the Model IM2RC/F-128K must be installed in the rear of a Patton 16 port rack or a 2, 4, or 8 port ClusterBox™ chassis. A front function card, such as a baseband modem, CSU/DSU, or HDSL modem meets the IM2RC/F-128K rear card in the mid-plane of the chassis. The IM2RC/F-128K also requires a G.703 connection to the 128 kbps co-directional PCM network and a line connection to a remote Patton transmission device. After applying power, the function card and IM2RC/F-128K operate transparently according to the applied settings (Please refer to the function card manual for further details).



**APPENDIX A**

**PATTON ELECTRONICS MODEL IM2RC/F-128K  
SPECIFICATIONS**

<b>Applications:</b>	128kbps G.703 PCM network extension
<b>G.703 Interfaces:</b>	Symmetrically balanced 4-wire, 120 Ohm RJ-45 jack termination
<b>Line Interface:</b>	Entire module plugs into 1092RC, 1092ARC, 1094ARC, and 1095RC HDSL Series Patton transmission devices products
<b>Operating Modes:</b>	Supports clear channel mode; co-directional timing, Rx recovered: 128 kbps±500ppm.
<b>Line Encoding:</b>	AMI with bi-polar violations for octet timing.
<b>Timing Modes:</b>	Modem or network timing
<b>G.703 Input Signal Sensitivity:</b>	0 to 9 dB loss @ 250 Khz
<b>Transmit Level:</b>	2.0V differential into 100 Ohms, nominal
<b>Load Impedance:</b>	120 Ohms
<b>Jitter Performance:</b>	CTR 14, G.823
<b>Surge Protection:</b>	Complies with IEC 801.5 level 1, 500V
<b>Isolation:</b>	1500V RMS isolation, transformer coupled
<b>PCB Dimensions:</b>	2.04" x 3.24"
<b>Compliance:</b>	CE Mark
<b>Power Consumption:</b>	<180mA @ 10 VAC RMS, including integrated front card modem with the rack card power supply under full load
<b>Temp. Range:</b>	0 - 60° C (32 - 140° F)
<b>Altitude Range:</b>	Up to 15,000 ft (4572 m)
<b>Humidity Range:</b>	5 - 95% non-condensing

**APPENDIX B**

**PATTON ELECTRONICS MODEL IM2RC/F-128K  
CABLE RECOMMENDATIONS**

All Patton Electronics Company Baseband Modems, CSU/DSUs and Short Range Modem are tested to the distances published in our Catalogs and Specification Sheets on twisted-pair cable with the following characteristics:

<u>Wire Gauge</u>	<u>Capacitance</u>	<u>Loop Resistance</u>
19 AWG	83nF/mi or 15.72 pF/ft.	.0163 ohms/ft.
22 AWG	83nF/mi or 15.72 pF/ft.	.0326 ohms/ft.
24 AWG	83nF/mi or 15.72 pF/ft.	.05165 ohms/ft.
26 AWG	83nF/mi or 15.72 pF/ft.	.08235 ohms/ft.

We fully expect that the Baseband Modems, CSU/DSUs and Short Range Modems will operate on lines with specifications different from those tested, but to reduce the potential difficulties in the field, one should ensure that the cable being used has similar or better characteristics (lower capacitance or lower resistance).

Wire with capacitance of 20pF/ft. or less is suitable for all Baseband Modems, CSU/DSUs and Short Range Modems. However, distances may vary from those published in our catalog. Resistance will also affect distance but not functionality. Wire should be 26 AWG or larger (smaller AWG#).

Patton products are designed to withstand normal environmental noise and conditions; however, other environmental factors too numerous to discuss in this format may affect proper operation.

Selection of the proper Baseband Modem, CSU/DSU or SRM for an application is critical to maintaining Customer Satisfaction and must be taken seriously. Certain models are better suited for particular applications and environments than others.

**APPENDIX C**

**PATTON ELECTRONICS IM2RC/F-128K  
FACTORY REPLACEMENT PARTS AND ACCESSORIES**

<u>Patton Model #</u>	<u>Description</u>
1000RCM12592.....	Rear card w/DB25F & RJ45 (V.24 interface)
1000RCM12492.....	Rear card w/ M/34F & RJ45 (V.35 interface)
1000RPEM .....	120/240V Rear Power Entry Module
1000RPSM-2 .....	120/240V Front Power Supply Module
1000RPEM-DC .....	DC Rear Power Entry Module
1000RPSM-48A.....	48V Front Power Supply Module
1000RPEM-V.....	120/240V CE Compliant Rear Power Entry Module
1000RPEM-V.....	120/240V CE Compliant Rear Power Supply Entry Module
1000CC.....	Control Card
1000RCM703/64DB...	Interface daughter card, G.703
1180RCDB.....	Interface daughter card, V24/V.35
0805US.....	American Power Cord
0805EUR .....	European Power Cord CEE 7
0805UK.....	United Kingdom Power Cord
0805AUS .....	Australia/New Zealand Power Cord
0805DEN .....	Denmark Power Cord
0805FR .....	France/Belgium Power Cord
0805IN .....	India Power Cord
0805IS .....	Israel Power Cord
0805JAP .....	Japan Power Cord
0805SW .....	Switzerland Power Cord
IM2RC/F-128K.....	G.703 Rear Card

**APPENDIX D**

**PATTON ELECTRONICS IM2RC/F-128K  
120 OHM G.703 INTERFACE PIN ASSIGNMENT**

**(RJ45 Female Connector)**

<u>Pin Number</u>	<u>Signal</u>
1.....	RX
2 .....	RX
3 .....	no connection
4.....	TX
5 .....	TX
6 .....	no connection
7 .....	no connection
8 .....	no connection

**APPENDIX E**

**PATTON ELECTRONICS IM2RC/F-128K  
LINE INTERFACE PIN ASSIGNMENT**

**(RJ45 Female Connector)**

<u>Pin Number</u>	<u>Signal</u>
1.....	4-Wire RX
2 .....	4-Wire RX
3 .....	no connection
4.....	2-Wire TIP/4-Wire TX
5 .....	2-Wire RING/4-Wire TX
6 .....	no connection
7 .....	no connection
8 .....	no connection