



DEFENSE INFORMATION SYSTEMS AGENCY

P. O. BOX 549
FORT MEADE, MARYLAND 20755-0549

IN REPLY REFER TO: Joint Interoperability Test Command (JTB)

11 June 2026

MEMORANDUM FOR DISTRIBUTION

SUBJECT: Joint Interoperability Certification of the Patton, LLC Tone Commander 4000 and 7000 Series IP Phone with Software Release XX.05.06

- References: (a) Department of Defense Instruction 8100.04, "DoD Unified Capabilities (UC)," 9 December 2010
(b) Office of the Department of Defense Chief Information Officer, "Department of Defense Unified Capabilities Requirements 2013 (UCR 2013) Change 2," September 2017
(c) through (e) see Enclosure 1

1. Certification Authority. Reference (a) establishes the Joint Interoperability Test Command (JITC) as the Joint Interoperability Certification Authority for the Department of Defense Information Network (DoDIN) products, Reference (b).

2. Conditions of Certification. The Patton, LLC Tone Commander 4000 and 7000 Series IP Phone with Software Release XX.05.06, hereinafter referred to as the System Under Test (SUT), meets the critical requirements of the Unified Capabilities Requirements, Reference (b), and is certified for joint use as a voice-only Assured Services Session Initiation Protocol (AS-SIP) End Instrument (AEI) with no conditions, as noted in Table 1. The Tone Commander 7810 was tested model. Based on JITC analysis, the Tone Commander 7810-PoE-TSGA and the 7810-PoE-TSGB models have similar hardware and operate on the same software as the tested model and are therefore also certified for joint use. The SUT is also certified for joint use with the following currently or previously certified Session Controllers: NEC UNIVERGE 3C Local Session Controller (LSC), REDCOM Laboratories Inc. High Density Exchange (HDX) LSC, REDCOM Laboratories Inc. Slice LSC, REDCOM Laboratories Inc. Sigma LSC, Ribbon Communications Federal Inc. Ribbon Application Server Enterprise Session Controller, and Unify Inc. OpenScope Voice LSC.

This certification expires upon changes that affect interoperability, but no later than three years from the date of this initial certification.

Table 1. Conditions

Table with 3 columns: Description, Operational Impact, Remarks. Row 1: None; the Patton, LLC Tone Commander 4000 and 7000 Series Internet Protocol Phone with Software Release XX.05.06 meets all critical joint interoperability requirements in accordance with the Unified Capabilities Requirements, Reference (b).

**3. Interoperability Status.** Table 2 provides the Interface Status, Table 3 provides the Capability Requirements and Functional Requirements status, and Table 4 provides the Product Summary SUT, to include subsequent Desktop Review (DTR) updates.

**Table 2. Interface Status**

Interface	Applicability	Status	Remarks
<b>IP Trunk Interfaces (See note 1.)</b>			
IEEE 802.3u (100BaseT)	C	Met	
IEEE 802.3ab (1000BaseT)	C	Met	
IEEE 802.3z (1000BaseX)	C	Not Tested	See note 2.
IEEE 802.3ae (10GBaseX)	C	Not Tested	See note 2.
<b>IP Line Interfaces (See note 1.)</b>			
IEEE 802.3u (100BaseT)	C	Met	
IEEE 802.3ab (1000BaseT)	C	Met	
IEEE 802.3z (1000BaseX)	C	Not Tested	See note 2.
IEEE 802.3ae (10GBaseX)	C	Not Tested	See note 2.
<b>Legacy Trunk Interfaces</b>			
ISDN T1 PRI NI2 (ANSI T1.619a)	R	Not Tested	See note 3.
ISDN T1 PRI NI2 (non-MLPP)	R	Not Tested	See note 3.
T1 CAS	O	Not Tested	See note 3.
E1 PRI (ITU-T Q.955.3)	C	Not Tested	See note 3.
E1 PRI (ITU-T Q.931)	C	Not Tested	See note 3.
E1 CAS	O	Not Tested	See note 3.
<b>Legacy Line Interfaces</b>			
2-wire Analog	R	Not Tested	See note 3.
ISDN BRI	O	Not Tested	See note 3.
<b>Network Management Interfaces (See note 1.)</b>			
IEEE 802.3i (10BaseT)	C	Met	
IEEE 802.3j (10BaseF)	C	Met	
IEEE 802.3u (100BaseT)	C	Met	
IEEE 802.3ab (1000BaseT)	C	Not Tested	See note 4.
IEEE 802.3z (1000BaseX)	C	Not Tested	See note 2.
IEEE 802.3ae (10GBaseX)	C	Not Tested	See note 2.
<b>NOTE(S):</b>			
1. The SUT shall support one or more of the Ethernet interfaces.			
2. The SUT does not support this conditional or optional interface.			
3. The SUT is an IP-only AEI and therefore does not support analog legacy trunk or line interfaces.			
4. The SUT is a voice-only AEI and therefore does not support this interface.			

(Table continues next page.)

**Table 2. Interface Status (continued)**

<b>LEGEND:</b>			
AEI	AS-SIP End Instrument	ITU-T	International Telecommunication Union - Telecommunication Standardization Sector
ANSI	American National Standards Institute	Mbps	Megabits Per Second
AS-SIP	Assured Services Session Initiation Protocol	MLPP	Multi-Level Precedence and Preemption
BaseF	Megabit Ethernet over Fiber	NI2	National ISDN Standard 2
BaseT	Megabit (Baseband Operation, Twisted Pair) Ethernet	O	Optional
BaseX	Megabit Ethernet over Fiber or Copper	PRI	Primary Rate Interface
BRI	Basic Rate Interface	Q.931	Signaling Standard for ISDN
C	Conditional	Q.955.3	ISDN Signaling standard for E1 MLPP
CAS	Channel Associated Signaling	R	Required
E1	European Basic Multiplex Rate (2.048 Mbps)	SUT	System Under Test
GBaseX	Gigabit Ethernet over Fiber or Copper	T1	Digital Transmission Link Level 1 (1.544 Mbps)
IEEE	Institute of Electrical and Electronics Engineers	T1.619A	ISDN Signaling standard for E1 MLPP
IP	Internet Protocol		
ISDN	Integrated Services Digital Network		

**Table 3. Capability Requirements and Functional Requirements Status**

<b>CR/FR ID</b>	<b>UCR Requirement</b> (See note 1.)	<b>UCR 2013 Change 2 Reference</b>	<b>Status</b>
1	Voice Features and Capabilities (R)	2.2	Met
2	Signaling Protocols (R)	2.4	Met
3	Registration and Authentication (R)	2.5	Met (See note 2.)
4	Product Interface (R)	2.7	Met
5	Product Physical, Quality, and Environmental Factors (R)	2.8	Met
6	End Instrument (R)	2.9	Met (See notes 2 and 3.)
7	Internet Protocol version 6 (R)	5.2	Met (See note 4.)
8	Assured Services - Session Initiation Protocol (AS-SIP 2013) (R)	AS-SIP 2013 Change 1 Reference (c)	Met (See note 5.)

**NOTE(S):**

- The annotation of 'required' refers to a high-level requirement category. Enclosure 3 addresses the applicability of each sub-requirement.
- A JITC-led Cybersecurity test team conducted a cybersecurity compliance review and published the results in a separate report, Reference (d).
- The SUT is not a secure voice AEI; therefore, the requirements for PEIs, AEIs, TAs, and IADs using the V.150.1 Protocol do not apply. Non-secure AEI phones do not use V.150.1; V.150.1 is used exclusively with TAs, IADs and secure AEI phones. DISA stated an intent to change the requirement to remove applicability for AEIs and PEIs.
- Due to limitations in the test architecture, testing was limited to only IPv6 intra-enclave.
- The SUT met the AS-SIP 2013 Change 1 requirements with testing and the Vendor's LoC IAW Reference (c).

**LEGEND:**

AEI	AS-SIP End Instrument	JITC	Joint Interoperability Test Command
AS-SIP	Assured Services Session Initiation Protocol	LoC	Letter of Compliance
CR	Capability Requirement	PEI	Proprietary End Instrument
DISA	Defense Information Systems Agency	R	Required
FR	Functional Requirement	SUT	System Under Test
IAD	Integrated Access Device	TA	Terminal Adaptor
IAW	In accordance with	UCR	Unified Capabilities Requirements
ID	Identification	V	Version
IPv6	Internet Protocol version 6		

**Table 4. Product Summary**

<b>Product Identification</b>			
Product Name	Tone Commander 4000 and 7000 Series IP Phone		
Software Release	XX.05.06		
UCR Product Type(s)	AEI		
Product Description	Tone Commander VoIP telephones are generic AEIs designed to interoperate with multiple types of Session Controllers. Patton IP phones include full support for precedence calls and provide dual-stack IPv4/IPv6 signaling. TLS and SRTP are used to secure signaling and voice transmission and PKI is used for server authentication. The only data connection to the phone is through Ethernet interfaces. Support for PoE, as well as a local power option, are provided. A 10/100BaseT switched Ethernet (unpowered) PC port is provided on the phone that can be used to connect a local workstation to the ASLAN over a shared drop provisioned with separate voice and data VLANs. The PC port can also be disabled.		
<b>Product Components</b> (See note 1.)	<b>Component Name</b> (See note 2.)	<b>Version</b>	<b>Remarks</b>
AEI	<b><u>Tone Commander 4101</u></b>	TC_07.05.06	Voice only
	<b><u>Tone Commander 7810</u></b>	TC_05.05.06	
	Tone Commander 7810PoE-TSGA		
	Tone Commander 7810PoE-TSGB		
	<b><u>Tone Commander 7910</u></b>	TC_09.05.06	
	Tone Commander 7910PoE-TSGA		
Tone Commander 7910PoE-TSGB			
<b>NOTE(S):</b>			
1. Table 3-3 in Enclosure 3 provides a detailed description of the initially tested components and sub-components.			
2. JITC tested bolded and underlined components. The other components in the product family were not tested; however, JITC certified the other components for joint use because they have similar hardware and operate on the same software as tested and certified components and JITC analysis determined they were functionally identical for interoperability certification purposes.			
<b>LEGEND:</b>			
AEI	AS-SIP End Instrument	SIP	Session Initiation Protocol
ASLAN	Assured Services Local Area Network	SRTP	Secure Real-Time Transport Protocol
AS-SIP	Assured Services Session Initiation Protocol	TC	Tone Commander
BaseT	Megabit (Baseband Operation, Twisted Pair) Ethernet	TLS	Transport Layer Security
IP	Internet Protocol	TSGA	Telephone Security Group A
JITC	Joint Interoperability Test Command	TSGB	Telephone Security Group B
LLC	Limited Liability Company	UCR	Unified Capabilities Requirements
PC	Personal Computer	v	version
PKI	Public Key Infrastructure	VLAN	Virtual Local Area Network
PoE	Power over Ethernet	VoIP	Voice over IP

**4. Test Details.** This certification is based on interoperability (IO) testing and review of the Vendor's Letter of Compliance (LoC). JITC completed review of the Vendor's LoC on 31 March 2025 and conducted IO testing at the JITC Unified Capabilities (UC) Test Lab located in the Joint Warfighter Test Center (JWTC), Fort Huachuca, Arizona, from 6 October through 10 October 2025, using test procedures derived from Reference (e). Follow-on V&V testing was conducted from 4 May through 8 May 2026 to validate functionality of the SUT following a software update to resolve IO discrepancies found during initial testing. A JITC-led Cybersecurity (CS) compliance team conducted a CS compliance review and published the results in a separate report, Reference (d). Enclosure 2 documents the test results and describes the test network and system configurations. Enclosure 3 provides a detailed list of the interface, capability, and functional requirements.

JITC Memo, JTB, Joint Interoperability Certification of the Patton, LLC Tone Commander 4000 and 7000 Series IP Phone with Software Release XX.05.06

**5. Additional Information.** JITC distributes interoperability information via the JITC Electronic Report Distribution system, which uses Sensitive but Unclassified Internet Protocol Data (formerly known as NIPRNet) e-mail. Interoperability status information is available via the JITC System Tracking Program (STP). STP is accessible by .mil/.gov users at <https://stp.jitc.disa.mil/>. Test reports, lessons learned, and related testing documents and references are on the JITC Industry Toolkit (JIT) at <https://jit.fhu.disa.mil/>. Due to the sensitivity of the information, the CS Assessment Package that contains the approved configuration and deployment guide must be requested directly from the JITC Specialized Test branch via e-mail: [disa.huachuca.eii-jitc.list.tssi-fhu@mail.mil](mailto:disa.huachuca.eii-jitc.list.tssi-fhu@mail.mil).

**6. Point of Contact (POC).** JITC POC: Jody Norris; Phone: (667) 890-7858; Teams DSN: 94 (323) 890-7858; E-mail: [jody.a.norris.civ@mail.mil](mailto:jody.a.norris.civ@mail.mil); Mailing address: Joint Interoperability Test Command, C/O JTB - Jody Norris, 2001 Brainard Road (MB59), Fort Huachuca, AZ 85613. The tracking number for the SUT is 2509001

FOR THE COMMANDER:

3 Enclosures a/s

LAWRENCE T. DORN  
Chief  
Force Support and Logistics Division

JITC Memo, JTB, Joint Interoperability Certification of the Patton, LLC Tone Commander 4000 and 7000 Series IP Phone with Software Release XX.05.06

**Distribution (electronic mail):**

DoD CIO  
Joint Staff J-6, JCS  
ISG Secretariat, DISA, JT  
U.S. Strategic Command, J66  
USSOCOM J65  
USTRANSCOM J6  
US Navy, OPNAV N2/N6FP12  
US Army, DA-OSA, CIO/G-6, SAIS-CBC  
US Air Force, SAF/A6SA  
US Marine Corps, MARCORSSYSCOM, SEAL, CERT Division  
US Coast Guard, CG-64  
DISA/ISG REP  
OUSD Intel, IS&A/Enterprise Programs of Record  
DLA, Test Directorate, J621C  
NSA/DT  
NGA, Compliance and Assessment Team  
DOT&E  
Medical Health Systems, JMIS PEO T&IVV  
HQUSAISEC, AMSEL-IE-ME  
APCO

## **ADDITIONAL REFERENCES**

(c) Office of the Department of Defense Chief Information Officer, "Department of Defense Assured Services (AS) Session Initiation Protocol (SIP) 2013 (AS-SIP 2013) Change 1," June 2015

(d) Joint Interoperability Test Command (JITC), "Cybersecurity Compliance Report For Interoperability Testing of Patton, LLC Tone Commander 4000 and 7000 Series IP Phone with Software Release XX.05.06, Tracking Number (TN) 2509001," May 2026 (Draft)

(e) JITC, "Soft Switch (SS) and Session Controller (SC) Test Procedures Version 1.1 for Unified Capabilities Requirements (UCR) 2013 Change 2," October 2022 (Draft)

## CERTIFICATION SUMMARY

**1. SYSTEM AND REQUIREMENTS IDENTIFICATION.** The Patton, LLC Tone Commander 4000 and 7000 Series IP Phone with Software Release XX.05.56, is hereinafter referred to as the System Under Test (SUT). Table 2-1 depicts the SUT identifying information and requirements source.

**Table 2-1. System and Requirements Identification**

<b>System Identification</b>			
Sponsor	Defense Information Systems Agency		
Sponsor Point of Contact	James Marshall, E-mail: <a href="mailto:james.e.marshall54.civ@mail.mil">james.e.marshall54.civ@mail.mil</a> ; Phone: 667-890-0134		
Vendor Point of Contact	Jerry Richards, Email: <a href="mailto:jrichards@patton.com">jrichards@patton.com</a> ; Phone: 425-349-1028		
System Name	Patton, LLC Tone Commander 4000 and 7000 Series IP Phone		
Increment and/or Version	XX.05.06		
Product Category	Voice-only AEI		
<b>System Background</b>			
Previous certifications	None		
<b>Tracking</b>			
Tracking Number	2509001		
System Tracking Program ID	4406		
<b>Requirements Source</b>			
Unified Capabilities Requirements	Unified Capabilities Requirements 2013, Change 2, Sections 2.2, 2.4, 2.5, 2.7, 2.8, 2.9, 5.2, and AS-SIP		
Remarks	None		
<b>Test Organization(s)</b>	Joint Interoperability Test Command, Fort Huachuca, Arizona		
<b>LEGEND:</b>			
AEI	AS-SIP End Instrument	IP	Internet Protocol
AS-SIP	Assured Services Session Initiation Protocol	LLC	Limited Liability Company
ID	Identification		

**2. SYSTEM DESCRIPTION.** The Department of Defense (DoD) Information Network (DoDIN) services include transport, data, voice, video, messaging, and other Unified Capabilities (UC) along with ancillary enterprise services. A key component of the DoDIN transport is the Assured Services Session Initiation Protocol (AS-SIP) End Instrument (EI) (AEI). An AEI is an EI that interfaces with a Session Controller (SC) using AS-SIP. A Proprietary End Instrument (PEI) interfaces with an SC using proprietary Voice and Video over Internet Protocol (IP) (VVoIP) signaling. Although not considered primary Session Control products, AS-SIP Gateways, Session Border Controllers (SBCs), and the DoDIN Stateful Firewall also have requirements in support of Session Control and session quality. Session Control requirements are described in terms of appliance functions associated with the Session Control products; these include the Call Connection Agent (CCA), Media Gateway (MG), Network Management (NM), and Assured Services Admission Control (ASAC). How the various DoDIN products are deployed within the network is described in the companion document entitled DoDIN Framework 2013.

The SUT is an AEI. Patton is continuing the evolution and updates for Tone Commander (Teo) Voice over IP (VoIP) telephones defined as generic AEIs designed to interoperate with multiple types of SCs. These IP phones include full support for precedence calls and provide dual-stack IP version (v) 4 (IPv4)/IPv6 signaling. Transport Layer Security (TLS) and Simple Real Time Protocol (SRTP) are used to secure signaling and voice transmission and Public Key Infrastructure (PKI) is used for server authentication. All model options operate using the same core software, which employs runtime checks to support various keyboard layouts and displays, and only Patton digitally signed software can be loaded or executed on the devices.

The primary data connection for these phones is provided through an Ethernet interface, with support for both Power over Ethernet (PoE) and local power options. Each phone includes a switched, unpowered Ethernet personal computer (PC) port used to connect a local workstation to the Assured Services Local Area Network (ASLAN). This connection is provisioned with separate voice and data Virtual Local Area Networks (VLANs), and the PC port can be disabled if necessary.

The SUT consists of the following components:

- **Tone Commander 4101** – The 4101 model features a smaller two-line display. It is designed to manage two call appearances within a simplified single-line presentation.
- **Tone Commander 7810** – The 7810 model is a 10-button telephone set equipped with a large display that support 10 multifunction keys. These keys can be configured for use as line keys, Direct Station Selection (DSS) keys, speed dials, or feature keys. This series includes the 7810, 7810 PoE-Telephone Security Group (TSG)A, and 7810PoE-TSGB variants, which incorporate hardware modifications to meet TSG-6 on-hook security requirements for deployment in Sensitive Compartmented Information Facility (SCIF) areas.
- **Tone Commander 7910** – The 7910, 7910PoE-TSGA, and 7910PoE-TSGB models are common to the 7810 family but feature two specific hardware upgrades. The network interfaces are upgraded from 10/100 to 10/100/1000 Ethernet connectivity, and the units include an additional Small Form-Factor Pluggable (SFP) receptacle to accommodate fiber connections using optional fiber SFP modules. No other changes in hardware or software were made from the 7810 models.

**Management Description.** Patton IP Phones are configured via Personal Identification Number (PIN)-protected setup menus on the phone or through eXtensible Markup Language (XML) configuration downloads from a managed Hypertext Transfer Protocol Secure (HTTPS) server provided as part of the SC solution. Configuration downloads occur when the phone initializes for the first time, or it can be initiated periodically or manually through the phone setup menus. Hypertext Transfer Protocol (HTTP) and Trivial File Transfer Protocol (TFTP) download protocols are supported, but they are not recommended for secure applications. The server address and protocol can be configured through the phone menus or via Dynamic Host Configuration Protocol (DHCP). There is no web server, Telnet, Secure Shell (SSH), administrative, or operating system (OS) access, including command line or other methods provided to the phone in released software versions.

**3. OPERATIONAL ARCHITECTURE.** The DoDIN architecture is a two-level network hierarchy consisting of DoDIN backbone switches and Service/Agency installation switches. The DoD Chief Information Officer and Joint Staff policy and subscriber mission requirements determine the type of switch allowable at a particular location. The DoDIN architecture, therefore, consists of several categories of switches. Figure 2-1 depicts the notional operational DoDIN architecture in which the SUT may be used.

**4. TEST CONFIGURATION.** The Joint Interoperability Test Command (JITC) test team tested the SUT at the Unified Capabilities (UC) Test Lab located in the Joint Warfighter Test Center (JWTC), Fort Huachuca, Arizona in a manner and configuration like the notional operational environment depicted in Figure 2-1. Figure 2-2 depicts the test configuration, components, and connectivity schemes employed during interoperability certification testing.

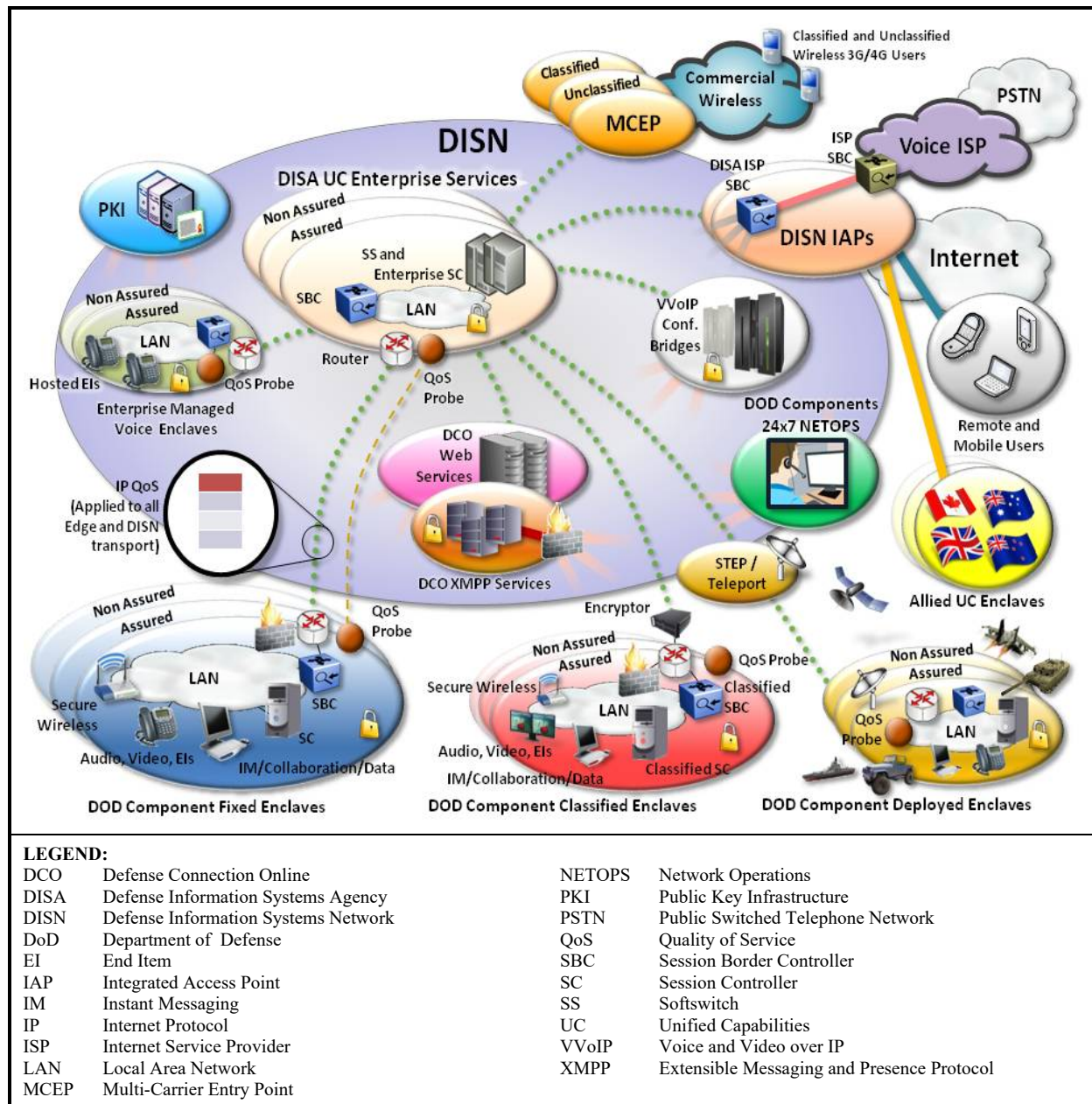
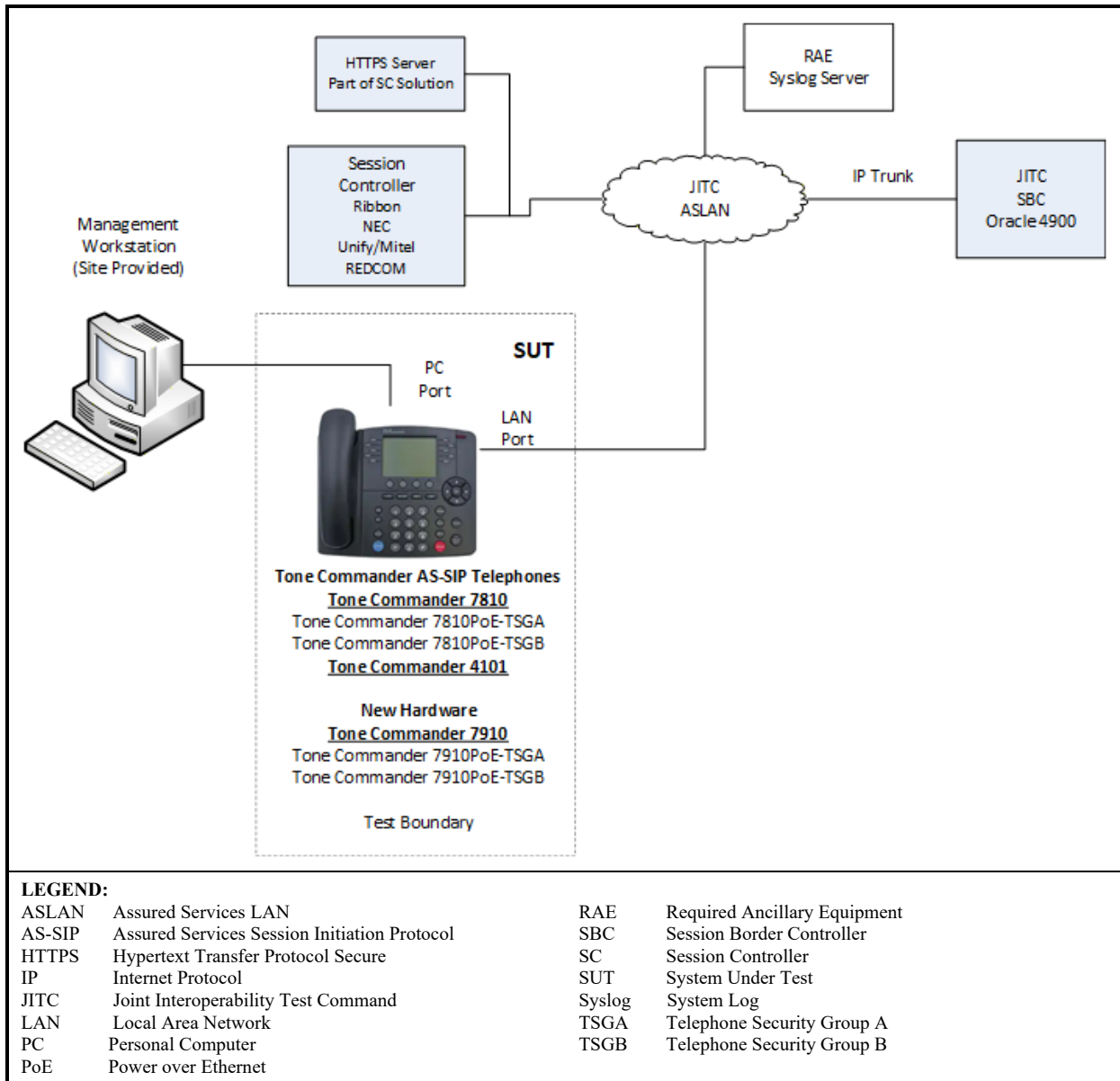

Figure 2-1. Notional DoDIN Network Architecture



**Figure 2-2. SUT Test Configuration**

**5. METHODOLOGY.** JITC conducted testing of the SUT in accordance with (IAW) AEI requirements derived from the Unified Capabilities Requirements (UCR) 2013, Change 2, Reference (b), and using AEI test procedures derived from Reference (e). In addition to testing, an analysis of the Vendor’s Letter of Compliance (LoC) verified the SUT met letter “R” requirements.

## **6. INTEROPERABILITY REQUIREMENTS, RESULTS, AND ANALYSIS.**

UCR 2013, Change 2, Sections 2.2, 2.4, 2.5, 2.7, 2.8, 2.9, and 5.2, established the interface, Capability Requirements (CR) and Functional Requirements (FR), Cybersecurity (CS), and other requirements for AEs. AS-SIP 2013 Change 1, Reference (c), established the CR and FR AS-SIP requirements. The subparagraphs below provide the testing details and results. Optional and/or conditional requirements are not included in the test results unless otherwise noted.

a. The UCR 2013, Change 2, Section 2.2, includes the requirements for Voice Features and Capabilities. The UCR 2013, Change 2, Section 2.2, includes the requirements for Voice Features and Capabilities and states that all Assured Services products, such as SCs and Soft Switches (SSs), are expected to support vendor-proprietary VVoIP features and capabilities. The Assured Services product's support for these vendor-proprietary VVoIP features and capabilities shall not adversely affect the required operation of the Multi-Level Precedence and Preemption (MLPP) or ASAC features on that product. The SUT met this requirement with testing and the Vendor's LoC. In addition, the SUT shall meet the requirements in the subparagraphs below.

1) UCR 2013, Change 2, Section 2.2.1, includes the requirements for Call Forwarding (CF). Four types of CF features are considered for UC: Call Forwarding Variable (CFV), Call Forwarding Busy Line (CFBL), Call Forwarding - Don't Answer - All Calls (CFDA), and Selective Call Forwarding (SCF). CF interaction with MLPP and a reminder ring for CF features are optional. The SUT met these requirements with testing and the Vendor's LoC.

2) The UCR 2013, Change 2, Section 2.2.2, includes the requirements for MLPP Interactions with CF. If a call is forwarded by a CF feature that supports MLPP, the precedence level of the call shall be preserved during the forwarding process. This section includes the following features: Call Forwarding at a Busy Station and Call Forwarding - No Reply at Called Station. The SUT met these requirements with testing.

3) The UCR 2013, Change 2, Section 2.2.3, includes the requirements for Precedence Call Waiting. The following treatments apply to precedence levels of PRIORITY and above: Busy With Higher Precedence Call, Busy With Equal Precedence Call, No Answer, Line Active With a Lower Precedence Call, and Call Waiting for Single Call Appearance VoIP Phones. The SUT met these requirements with testing.

4) The UCR 2013, Change 2, Section 2.2.4, includes the requirements for Call Transfer. The two types of call transfers are normal and explicit. A normal call transfer is a transfer of an incoming call to another party. An explicit call transfer happens when both calls are originated by the same subscriber. This section includes the following features: Call Transfer Interaction at Different Precedence Levels and Call Transfer Interaction at Same Precedence Levels. The SUT met these requirements with testing.

5) The UCR 2013, Change 2, Section 2.2.5, Call Hold, states that the calls on hold shall retain the precedence of the originating call. The SUT met this requirement with testing.

6) The UCR 2013, Change 2, Section 2.2.6, includes the requirements for Three-Way Calling (TWC) in the sub-paragraphs below.

a) In TWC, each call shall have its own precedence level. When a three-way conversation is established, each connection shall maintain its assigned precedence level. Each connection of a call resulting from a split operation shall maintain the precedence level that it was assigned upon being added to the three-way conversation. The SUT met these requirements with testing.

b) The SC/SS shall class mark the originator of the three-way call at the highest precedence level of the two segments of the call. Incoming calls to lines participating in TWC that have a higher precedence than the higher of the two segments shall preempt unless the call is marked non-preemptable. The SUT met these requirements with testing.

c) When a higher precedence call is placed to any one of the three-way call participants (including the originator), that participant shall receive the preemption tone (see Table 2.9-2, UC Information Signals). The other two parties shall receive either a conference disconnect tone or a preemption tone as described in Table 2.9-2. This tone indicates to the other parties that one of the other three-way call participants is being preempted and is exiting the conference. The remaining participants may remain connected, or may be disconnected, in accordance with (IAW) the requirements that follow in this section. The SUT met these requirements with testing.

d) When the originator of the TWC is on an AEI and is being preempted, the other two parties shall be disconnected from the three-way call. The SUT met these requirements with testing.

e) When the originator of the TWC is on a Proprietary End Instrument (PEI) and is being preempted, if the TWC bridge is provided by the PEI, the other two parties shall be disconnected from the three-way call. The SUT is an AEI; therefore, this PEI requirement does not apply.

f) When the originator of the three-way call is on a PEI and is being preempted, if the TWC bridge is provided by the SC or a Media Server, then the other two parties shall remain connected. The SUT is an AEI; therefore, this PEI requirement does not apply.

g) TWC for AEIs and PEIs. TWC shall be supported by AEIs consistent with AS-SIP 2013, for TWC and the following sections of Request for Comment (RFC) 5359:

- Section 2.10, Three-Way Conference – Third Party is Added.
- Section 2.11, Three-Way Conference – Third Party Joins.

The SUT met these requirements with testing.

h) The TWC mixer/bridge shall be located in the AEI. For PEIs, the mixer/bridge can be provided by the PEI, SC, or a Media Server. The SUT met this requirement as an AEI with testing.

7) The UCR 2013, Change 2, Section 2.2.7, includes the requirements for Hotline Service. The SUT does not support these optional requirements.

8) The UCR 2013, Change 2, Section 2.2.8, includes the requirements for Calling Number Delivery in the sub-paragraphs below.

a) The calling number provided to the called party shall be determined by the dialing plan used by the calling instrument, IAW Telcordia Technologies GR-31-CORE. The SUT met this requirement with testing and the Vendor's LoC.

b) If the incoming call is from another Defense Switched Network (DSN) user, the calling number shall be delivered to the called party in 10-digit DSN number format. The SUT met this requirement with testing and the Vendor's LoC.

c) If the incoming call is from a commercial user, the calling number shall be delivered to the called party in national or international calling number format. The SUT met this requirement with testing and the Vendor's LoC.

d) The UC products shall support delivery of Calling Name information to SC end users on incoming UC calls. The SUT met this requirement with testing and the Vendor's LoC.

e) The UC products shall support delivery of Calling Party Org and Location information (e.g., the caller's military unit and location identity) to SC end users. The SUT does not support this optional requirement.

9) The UCR 2013, Change 2, Section 2.2.9, includes the requirements for Call Pick-Up in the sub-paragraphs below.

a) A user EI shall be equipped to answer any calls directed to other EI within the user's own preset pick-up group, as established by an administrative facility, by dialing the appropriate feature code. Three types of Call Pick-Up features are considered for UC:

1. Basic Call Pick-Up. An EI may answer a call that has been offered to another EI in its common call pick up group in a business group. This is accomplished by dialing a pickup access code while the called EI is ringing. If more than one EI in the group is ringing, then the EI that has been ringing longer shall be picked up first. The SUT met this requirement with the Vendor's LoC.

2. Directed Call Pick-Up. Directed call pick-up permits a user to dial a code and destination number and pick up a call that has been answered or is ringing at another telephone, provided the rung telephone permits dial pick-up. If the other EI has answered, a TWC is established. The SUT met this requirement with the Vendor's LoC.

3. Directed Call Pick-Up Without Barge-In. This feature is identical to the Directed Call Pick-Up feature, except that if the destination number being picked up has already answered, the party dialing the pick-up code shall be routed to reorder rather than be permitted to barge in on the established connection to create a TWC. The SUT met this requirement with the Vendor's LoC.

b) If a Call Pick-Up feature is provided, it shall be IAW Telcordia Technologies GR-590-CORE. The SUT met this requirement with the Vendor's LoC.

c) If a Call Pick-Up feature is provided, it shall interact with MLPP IAW the following:

1. If a call pick-up group has more than one party in an unanswered condition and the unanswered parties are at different precedence levels, a call pick-up attempt in that group shall retrieve the highest precedence call first. If multiple calls of equal precedence are ringing simultaneously, a call pick-up attempt in that group shall retrieve the longest ringing call first. The SUT met this requirement with the Vendor's LoC.

2. If a party in a call pick-up group is busy, and an incoming precedence call is placed to that number, normal MLPP rules shall apply. This call cannot be picked up within the call pick-up group unless it is an unanswered call, provided there are no additional features such as Call Waiting or CF. The SUT met this requirement with the Vendor's LoC.

10) The UCR 2013, Change 2, Section 2.2.10, includes the requirements for Precedence Call Diversion in the sub-paragraphs below.

a) Precedence Call Diversion shall be supported on calls from one UC EI to another UC EI on the same SC. The SUT met this requirement with testing.

b) Precedence Call Diversion shall be supported on calls from a UC EI on one SC to a UC EI on another SC. The SUT met this requirement with testing.

c) Precedence Call Diversion shall be supported on calls from a UC EI on an SC to a DSN EI (on an End Office [EO], Small EO (SMEO), Private Branch Exchange [PBX] 1, or PBX 2). The SUT met this requirement with testing.

d) Precedence Call Diversion shall be supported on calls from a DSN EI (on an EO, SMEO, PBX 1, or PBX 2) to a UC EI on an SC. The SUT met this requirement with testing.

e) The AS-SIP signaling appliance shall divert ALL unanswered UC VoIP calls above the ROUTINE level to a designated Directory Number (DN) for Precedence Call Diversion (PCD) (e.g., the number of an attendant console or group of attendant consoles). This diversion shall occur after a specified PCD time period, selectable from 15–45 seconds, and configurable at the per-appliance level. The SUT met this requirement with testing.

f) Unanswered UC VoIP calls above the ROUTINE precedence level shall not be forwarded to voicemail and shall not be forwarded to Automatic Call Distribution (ACD) systems. Instead, they shall divert to the PCD DN when the PCD time period expires. The SUT met this requirement with testing.

g) Unanswered UC VoIP ROUTINE calls to DNs that are configured with voicemail or an ACD system shall be forwarded to voicemail or to the ACD system. The SUT met this requirement with testing.

h) Calls above the ROUTINE precedence level that are directly dialed to DNs assigned to voicemail or ACD systems shall divert to the PCD DN as specified above (i.e., when they are unanswered at the voicemail or ACD system, and the PCD time period expires). The SUT met this requirement with testing.

i) The AS-SIP signaling appliance shall support a per-appliance configuration option that, when activated, diverts ROUTINE calls directly dialed to DNs assigned to voicemail or ACD systems to the PCD DN, if they go unanswered and the PCD time period expires. These calls shall keep their ROUTINE precedence level after they are diverted by PCD. When this configuration option is not used, unanswered ROUTINE calls shall continue to be offered to the voicemail or ACD system and shall not be diverted by PCD. The SUT met this requirement with testing.

j) During configurable time periods, an announcement that identifies the DSN number of a continuously manned attendant station or console shall be provided to the calling party of a call that would otherwise be diverted to the designated PCD DN. The purpose of this optional requirement is to provide an alternative treatment if there are time periods during which calls to the PCD DN are not expected to be answered. The SUT does not support this optional requirement.

**b.** The UCR 2013, Change 1, Section 2.4, includes the requirements for Signaling Protocols. This section also includes the Signaling Performance Guidelines, which include call setup and call tear-down times as well as guidelines for intra-enclave, inter-enclave and worldwide calls. The SUT met this requirement with testing.

**c.** The UCR 2013, Change 2, Section 2.5, includes the requirements for Registration and Authentication in the sub-paragraphs below.

1) Registration and authentication between Network Elements (NEs) shall follow the requirements set forth in Section 4, Cybersecurity. This section includes additional Network Time Protocol (NTP) requirements. Per the UCR, this section is not interoperability tested. The SUT met the requirements in UCR 2013, Change 2, Section 4, with testing and the Vendor's LoC. In addition, a JITC-led CS test team conducted a CS compliance review and published the results in a separate report, Reference (d).

a) If a Session Control appliance uses NTP, then NTP version (v) 3 (NTPv3) shall be used and authentication shall be performed. The SUT met this requirement with testing and the Vendor's LoC.

b) If a Session Control appliance uses NTP and the NTPv3 implementation supports authentication using Public Key Infrastructure (PKI), then PKI-based authentication shall be performed. The SUT met this requirement with testing and the Vendor's LoC.

c) If a Session Control appliance uses NTP and the NTPv3 implementation does not support PKI, then authentication shall be performed using Secure Hash Algorithm (SHA)-1 or Message Digest (MD) 5. MD5 shall be used only when SHA-1 is not supported by either the NTP client or NTP server. The SUT met this requirement with testing and the Vendor's LoC.

d. The UCR 2013, Change 2, Section 2.7, includes the requirements for Product Interfaces. This includes requirements for internal and external physical interfaces, interfaces to other networks, and DISA VVoIP EMS Interface.

1) The UCR 2013, Change 2, Section 2.7.1, states that internal interfaces are functions that operate internal to a System Under Test (SUT) or UC-approved product (e.g., SC, SS). The interfaces between SC/SS functions within an SC and Signaling Gateway (SG) are considered internal to the SC regardless of the physical packaging. These interfaces are vendor-proprietary and unique, especially the protocol used over the interface. Whenever the physical interfaces use Institute of Electrical and Electronics Engineers, Inc. (IEEE) 802.3 Ethernet standards, they shall support auto-negotiation even when the IEEE 802.3 standard has it as optional. This applies to 10/100/1000-T Ethernet standards; i.e., IEEE, Ethernet Standard 802.3, 1993; or IEEE, Fast Ethernet Standard 802.3u, 1995; and IEEE, Gigabit Ethernet Standard 802.3ab, 1999. The SUT met the requirements for IEEE 802.3i 10 Mbps, IEEE 802.3u 100 Mbps Fast Ethernet, and IEEE 802.3ab 1000 Mbps with testing.

2) The UCR 2013, Change 2, Section 2.7.2, states External Physical Interfaces Between Network Components are functions that cross the demarcation point between SUT and other external network components. Whenever the physical interfaces use IEEE 802.3 Ethernet standards, they shall support auto-negotiation even when the IEEE 802.3 standard has it as optional. This applies to 10/100/1000-T Ethernet standards; i.e., IEEE, Ethernet Standard 802.3, 1993 or IEEE, Fast Ethernet Standard 802.3u, 1995; and IEEE, Gigabit Ethernet Standard 802.3ab, 1999. This requirement does not preclude the use of other types of physical interfaces. The SUT met this requirement with the Vendor's LoC.

a) The SC (and its appliances), SS, SBC, AEI, and PEI shall support one or more of the following Ethernet physical interfaces (compliant to IEEE 802.3 standards) to ASLAN switches and routers.

- 100 Mbps IAW IEEE 802.3u.
- 1000 Mbps IAW IEEE 802.3z.
- 1000 Mbps IAW IEEE 802.3ab.
- 10 Gbps IAW IEEE 802.3ae.

NOTE: This requirement does not preclude the inclusion and use of other types of physical interfaces.

The SUT met this requirement for IEEE 802.3i 10 Mbps, IEEE 802.3u 100 Mbps Fast Ethernet, and IEEE 802.ab 1000 Mbps with testing and the Vendor's LoC.

b) If the physical interface supports multiple Ethernet rates, it shall support auto-negotiation. The SUT met this requirement with testing. Additionally, the SUT met the requirements for IEEE 802.3i 10 Mbps, IEEE 802.3u 100 Mbps Fast Ethernet, and IEEE 802.ab 1000 Mbps with testing.

c) If the physical interface supports both 100 Mbps (802.3u) and 1 Gbps (802.3ab), it shall support auto-negotiation. The SUT met this requirement with testing.

e. The UCR 2013, Change 2, Section 2.8, includes the requirements for Product Physical, Quality, and Environmental in the subparagraph below.

1) The UCR 2013, Change 2, Section 2.8.4, states that, for the VoIP devices, the voice quality shall have a Mean Opinion Score (MOS) of 4.0 (R-Factor equals 80) or better, as measured IAW the E-Model. Additionally, these devices shall not lose two or more consecutive packets in a minute and shall not lose more than seven voice packets (excluding signaling packets) in a 5-minute period. This applies only to devices that generate media and have a Network Interface Card (NIC). The SUT met this requirement with testing with an average MOS of 4.4.

f. The UCR 2013, Change 2, Section 2.9, includes the requirements for EIs in the subparagraphs below.

1) The UCR 2013, Change 2, Section 2.9.1, includes the requirements for IP Voice EIs. An IP voice instrument shall be designed IAW the acquiring activity requirements, but the following capabilities are required if not stated otherwise.

a) DoD Common Access Card (CAC) reader. See Section 4.2.3.5, Authentication Practices, item 1h(1), for SC and EI requirements on PKI and CAC authentication, and SC and EI requirements on Username and Personal Identification Number (PIN) authentication. The SUT met the requirements for Username and PIN authentication with testing.

b) Display calling number. (See Section 2.2.8, Calling Number Delivery, for SC and EI requirements on the Calling Number Delivery feature.). The SUT met this requirement with testing as noted in Section 2.2.8 above.

c) Display precedence level of the session. The SUT met this requirement with testing.

d) Use of DSCPs in signaling and media streams. The SUT met this requirement with testing.

e) Support for Dynamic Host Configuration Protocol (DHCP). The SUT met this requirement with testing.

1. The UCR 2013, Change 2, Section 2.9.1.2.1, includes the requirements for UC Ringing Tones, Cadence, and Information Signals provided in the subparagraphs below.

a. The UC EIs and signaling appliances shall provide alerting (ringing) for precedence calls (i.e., PRIORITY and above) that is distinct from the alerting for ROUTINE calls. The SUT met this requirement with testing.

b. The UC EIs and signaling appliances shall implement the ringing tones and cadences shown in Table 2.9-1, UC Ringing Tones, and Cadences. The SUT met this requirement with testing.

c. The AEs shall be able to provide customized ring tones for incoming precedence calls using pre-recorded audio files (e.g., Moving Pictures Expert Group [MPEG] Audio Layer-3 [MP3], Augmentative and Alternative Communication [AAC] [.m4a and .m4r], Waveform Audio File [WAV], Windows Media Audio [WMA], Ogg Vorbis Compressed Audio [OGG]) that are stored in the AEs. For example, an AE may store one audio file for use with ringing on incoming PRIORITY calls, another file for use with ringing on incoming IMMEDIATE calls, another file for use with ringing on incoming FLASH calls, and so on. Different audio files can also be associated with different calling numbers when that calling number is used on a Precedence calls (e.g., “This is an IMMEDIATE call from General John Smith.”). The SUT does not support this optional requirement.

d. The EIs and signaling appliances shall implement the UC information signals shown in Table 2.9-2, UC Information Signals. The SUT met this requirement with testing.

2. The UCR 2013, Change 2, Section 2.9.1.2.2, includes the requirements for Announcements provided in the subparagraphs below.

a. The announcements in Table 2.9-3, Required Announcements, shall be supported, along with all announcements that are associated with a specific Network Management trunk group and/or code control implementation. Each announcement shall contain a location identification number to be provided by the Government. The appliance playing the announcement (or serving the EI that is playing the announcement) shall be identified by “Switch Name and Location.” Announcements shall be capable of being recorded and changed by Government operations and maintenance (O&M) personnel. Additional local messages may be added and optionally activated, deactivated, or modified via administrative or operational controls. The SUT met this requirement with testing.

b. If an announcement in Table 2.9-4, Optional Announcements, is provided, it shall contain a location identification number to be provided by the Government. The appliance playing the announcement (or serving the EI that is playing the announcement) shall be identified by “Switch Name and Location.” Announcements shall be capable of being

recorded and changed by Government O&M personnel. The SUT does not support this optional requirement.

3. The UCR 2013, Change 2, Section 2.9.1.2.3, includes the requirements for Loss of Command and Control (LOC2) Features Announcement provided in the subparagraphs below.

a. The LOC2 Features announcement applies only to calls placed via an SC media gateway (MG) or an SS MG to a non-MLPP Primary Rate Interface (PRI) or Channel Associated Signaling (CAS) trunk and shall be provided IAW the following:

- Play only for calls above the ROUTINE precedence level.
- Not required for locally originated calls to non-MLPP PRI or CAS trunks (e.g., Public Switched Telephone Network).
- Appropriate for VoIP calls received from the DISN wide area network (WAN), or calls received from a base MLPP tie trunk via an MG, that are destined to tandem via an SC MG or SS MG to a non-MLPP PRI or CAS trunk.
- Play before ringback is provided to the caller.
- Play before cut-through to the non-MLPP trunk. This prevents ringback from interfering with the announcement.
- The announcement shall be played into the media stream at the MG point of departure from the DISN to the non-MLPP trunk.
- The LOC2 announcement is not signaled by AS-SIP.

The SUT does not support the optional LOC2 Features announcement requirement.

f) The UCR 2013, Change 2, Section 2.9.1.3, includes the requirements for Audio Codecs, Voice Instruments provided in the subparagraphs below.

1. EIs shall support the origination and termination of a voice session using the International Telecommunication Union - Telecommunication Standardization Sector (ITU-T) Recommendation G.711 codec, including both the  $\mu$ -law and A-law algorithms. The SUT met this requirement with testing and the Vendor's LoC.

2. EIs shall support the origination and termination of a voice session using the ITU-T Recommendation G.729 or G.729A codec. The SUT met this requirement with testing and the Vendor's LoC.

3. EIs shall support the origination and termination of a voice session using the ITU-T Recommendation G.723.1 codec. The SUT does not support this optional audio codec.

4. EIs shall support the origination and termination of a voice session using the ITU-T Recommendation G.722.1 codec. The SUT met this optional requirement with testing and the Vendor's LoC.

The product is not required to do transcoding between codec types, but shall support, via signaling during session setup, the offer/negotiation between origination and destination EIs of the codec type to be used for the session.

g) The UCR 2013, Change 2, Section 2.9.1.4, includes the requirements for Voice over IP PEI or AEI Telephone Audio Performance. Voice over IP PEIs or AEIs (i.e., handset, headset, and hands-free types) shall comply with Telecommunications Industry Association (TIA)-810-B, November 3, 2006. The SUT met this requirement with the Vendor's LoC.

h) The UCR 2013, Change 2, Section 2.9.1.5, includes the requirements for Voice over IP Sampling Standard. For Fixed-to-Fixed calls, the product shall use 20 milliseconds as the default voice sample length, and as the basis for the voice payload packet size. For other call types, e.g., Fixed-to-Deployable calls, the product shall use different voice sample lengths and voice payload packet sizes, as negotiated during call setup via the Session Description Protocol (SDP). The SUT met this requirement with testing, including validation that the SUT uses a default 20 millisecond voice sample size for all IP traffic based on a wire shark and Session Initiation Protocol (SIP) log captures whether it be Fixed-to-Fixed calls or Fixed-to-Deployable calls.

i) The UCR 2013, Change 2, Section 2.9.1.6, includes the requirements for Softphones. A softphone is an end-user software application on an approved operating system that enables a general-purpose computer to function as a telephone PEI/AEI. The softphone application is considered an IP PEI-AEI. It is associated with the IP telephone switch and will be tested on an approved operating system as part of the SUT.

1. If a softphone is supported by an SC or SS, the softphone shall be conceptually identical to a traditional IP "hard" telephone and is required to provide voice features and functionality provided by a traditional IP hard telephone, unless explicitly stated here within this paragraph. The softphone application in conjunction with a general-purpose computer, including its mouse (point and click) interaction, shall support, as a minimum, the following requirements:

- Section 2.2, Voice Features and Capabilities.
- Section 2.9.1.1, Basic.
- Section 2.9.1.2, Tones and Announcements.
- Section 2.9.1.3, Audio Codecs, Voice Instruments.
- Section 2.9.1.4, VoIP PEI or AEI Telephone Audio Performance.
- Section 2.9.1.5, Voice over IP Sampling Standard.
- Section 2.9.4, Authentication to SC.
- Section 2.9.5, EI to ASLAN Interface.

- Section 6, Network Infrastructure End-to-End Performance. The softphone application shall be exempt from the performance (i.e., packet loss, jitter, latency) requirements specified in Section 6, Network Infrastructure End-to-End Performance, e.g., the PEI/AEI 50-millisecond latency for the G.711 codec.
- Section 6.3.2, Traffic Conditioning Specification.
- Section 4, Cybersecurity.

2. If an EI is a softphone, then it shall inhibit any screen saver or lock screen capability whenever the softphone application is active (i.e., user is on a call). This is to avoid the situation where the user needs to interact with the softphone application via the mouse or keyboard expeditiously (e.g., respond to a new call) but first needs to re-login.

The SUT is not a softphone; therefore, the conditional softphone requirements do not apply.

j) The UCR 2013, Change 2, Section 2.9.1.7, includes the requirements for DSCP Packet Marking provided in the subparagraphs below.

1. As part of the session setup process, the SC controls what DSCP to use in the subsequent session media stream packets. For inter-SC media sessions (across the WAN), and intra-SC media sessions (internal to the enclave), one of the following occurs:

- The PEI shall be commanded by the SC about which DSCP to insert in the session media stream packets.
- The PEI shall populate the DSCP marking on its own.
- The AEI shall populate the DSCP marking on its own.

The SUT met these requirements with testing. Wireshark was used to capture and verify call data.

2. The exact DSCP method used by the implementer shall comply with Section 6, Network Infrastructure End-to-End Performance. The session's media type (e.g., audio vs. video) and the session's precedence level (ROUTINE (R), PRIORITY (P), IMMEDIATE (I), FLASH (F), or FLASH OVERRIDE (FO)) shall be used to determine the media stream DSCP for that session. The SUT met this requirement with testing.

NOTE: This DSCP marking data can be provisioned in the AEI or PEI as part of the information downloaded to the EI from a provisioning server after the EI completes its registration with the SC.

2) The UCR 2013, Change 2, Section 2.9.3, includes the requirements for Video EI provided in the subparagraphs below.

a) The UCR 2013, Change 2, Section 2.9.3.1, includes the requirements for Basic. An IP video EI shall be designed IAW the acquiring activity requirements, but the following capabilities are specifically required or optional as indicated.

- DoD CAC card reader (optional requirement). The SUT does not support this optional requirement.
- Automatic enabling of the video camera is not permitted after video session negotiation or acceptance. The called party must take a positive action to enable the camera. The SUT is a voice-only AEI; therefore, video requirements do not apply.
- Display calling number. The SUT met this requirement with testing.
- Display precedence level of the session (optional requirement). The SUT met this requirement with testing.
- Support for MLPP feature (optional requirement). The SUT met this requirement with testing.
- Support for DHCP. The SUT met this requirement with testing.

b) The UCR 2013, Change 2, Section 2.9.3.2, includes the requirements for Display Messages, Tones, and Announcements provided in the following subparagraphs. As appropriate for voice and video over IP, and as required, in Section 2.9.1.2.1, UC Ringing Tones, Cadences, and Information Signals, and Section 2.9.1.2.2, Announcements, shall be supported by the PEI and AEI, except for the loss of the command-and-control announcement. These tones and announcements shall be generated locally by the PEI and AEI on the command of the SC or generated on command of the SC by an internal SC Media Server or an external Media Server connected to the ASLAN and passed as a media stream to the PEI and AEI. Regardless of how implemented, the Media Server is part of the SC SUT. The SUT met the AEI requirements with an external Media Server included with its registered SC with testing.

c) The UCR 2013, Change 2, Section 2.9.3.3, includes the requirements for Video Codecs (Including Associated Audio Codecs) provided in the subparagraphs below.

1. The product shall support the origination, maintenance, and termination of a video session using the following codecs: one G.xxx and one H.xxx shall be used to create and sustain a video session. (All video and audio capabilities in the PEI or AEI shall be sent to the terminating PEI or AEI for negotiation about which video and audio codec to use for the session.)

2. Video PEIs and AEIs shall support, at a minimum, G.711 Pulse Code Modulation (PCM), where PCM has a static payload type value of 0 and a clock rate of 8000. The PCM shall support both the  $\mu$ -law and A-law algorithms.

3. It is recommended that video PEIs and AEIs support other audio codecs in addition to G.711 PCM. Recommended audio codecs include the following recommendations.

a. ITU-T Recommendation G.722, where G.722 has a static payload type value of 9 and a clock rate of 8000.

b. ITU-T Recommendation G.722.1, where G.722.1 has the encoding name “G7221”, a clock rate of 16000, and a standard bit rate of 24 Kilobits per second (Kbps) or 32 Kbps.

c. ITU-T Recommendation G.723.1, where G.723.1 has the encoding name “G723”, a clock rate of 8000, and standard bit rates of 5.3 Kbps and 6.3 Kbps.

d. ITU-T Recommendation G.729, where G.729 has the encoding name “G729”, a clock rate of 8000, and a standard bit rate of 8 Kbps.

e. ITU-T Recommendation G.729 Annex A (G.729A), where G.729A also has the encoding name “G729”, a clock rate of 8000, and a standard bit rate of 8 Kbps.

4. Video PEI and AEI shall support, at a minimum, the following video codecs: ITU-T Recommendation H.264.

5. Video PEI and AEI shall optionally support the following video codecs.

- ITU-T Recommendation H.263.
- ITU-T Recommendation H.261.
- ITU-T Recommendation H.263v3 (H.263 2000).
- ITU-T Recommendation H.264 Scalable Video Coding.

The SUT is a voice-only AEI; therefore, the video requirements do not apply.

d) The UCR 2013, Change 2, Section 2.9.3.4, includes the requirements for H.323 VTC provided in the subparagraphs below.

1. The H.323 VTC system and end points should meet the requirements of Federal Telecommunications Recommendation (FTR) 1080B-2002.

2. The H.323 VTC features and functions used in conjunction with IP network services should meet the requirements of H.323 IAW FTR 1080B-2002, and H.323 video EIs should meet the tagging requirements as specified in Section 7, Network Edge Infrastructure.

3. When supporting H.323, a loss of any conferee on a multipoint H.323 videoconference shall not terminate or degrade the DSN service supporting H.323 VTC connections of any of the other conferees on the videoconference.

4. An audio add-on interface shall be provided on H.323 VTC equipment IAW Section 3.7, Customer Premise Equipment.

5. When supporting H.323, physical, electrical, and software characteristics of a video teleconferencing unit system or end point that is used in the DISN network shall not degrade, or impair, the DISN service and its associated network operations. As noted in the introduction to Section 2.3.3, ASAC Requirements for the SC and the SS Related to Video Services, the SC and the SS will process only AS-SIP video. H.323 video will be processed by a gatekeeper appliance.

The SUT is a voice-only AEI; therefore, the video requirements do not apply.

3) The UCR 2013, Change 2, Section 2.9.4, includes the requirements for Authentication to SC. The PEI and AEI shall each be capable of authenticating itself to its associated SC and vice versa IAW Section 4, Cybersecurity. The SUT met this requirement with testing and the Vendor's LoC. A JITC-led CS test team conducted a CS compliance review and published the results in a separate report, Reference (d).

4) The UCR 2013, Change 2, Section 2.9.5, includes the requirements for EI to ASLAN Interface. The interface to the ASLAN shall be IAW Ethernet (IEEE 802.3) LAN technology. The 10-Mbps and 100-Mbps Fast Ethernet (IEEE 802.3u) shall be supported. The SUT met this requirement with testing.

5) The UCR 2013, Change 2, Section 2.9.6, includes the requirements for Operational Framework for AEIs provided in the following subparagraphs. This section contains SC and AEI requirements to support a generic, multivendor-interoperable interface between a VVoIP SC and an AS-SIP VVoIP EI, which can be a voice EI, a secure voice EI, or a video EI. This generic, multivendor-interoperable interface uses AS-SIP protocol instead of the various vendor-proprietary SC-to-EI protocols. Note: International Telecommunication Union Recommendation H.323 and Internet Engineering Task Force SIP (commercial SIP, not DISA-specified AS-SIP) are both considered vendor-proprietary SC-to-EI protocols here. The SUT met the AS-SIP protocol requirements with testing.

a) The UCR 2013, Change 2, Section 2.9.6.1, includes the requirements for Supporting AEIs provided in the subparagraphs below.

1. The AEIs (voice, secure voice, and video) shall follow all the previous requirements for EIs (voice and video, with secure voice EIs following the previous requirements for voice EIs), except for those requirements that involve vendor-proprietary SC-to-EI signaling. The SUT met the requirement for non-secure voice with testing.

2. The SC and AEIs (voice, secure voice, and video) shall support mutual authentication using AS-SIP and Transport Layer Security (TLS) signaling instead of vendor-proprietary signaling. That is, each AEI shall authenticate itself with its serving SC using AS-SIP and TLS signaling, and each SC shall authenticate itself with the AEIs that it serves using AS-SIP and TLS signaling. The SUT met the requirement for non-secure voice with testing.

3. A single AEI shall support voice, secure voice, and video capabilities. In this case, the EI shall support those capabilities IAW the combined requirements for an AS-SIP voice

EI, an AS-SIP secure voice EI, and an AS-SIP video EI, as given in Section 2.9.6.2, Requirements for AS-SIP Voice EIs; Section 2.9.6.3, Requirements for AS-SIP Secure Voice EIs; and Section 2.9.6.4, Requirements for AS-SIP Video EIs. The SUT is a voice-only AEI; therefore, the optional combined voice, secure voice, and video requirements do not apply.

4. A single AEI shall support both voice and secure voice capabilities. In this case, the EI shall support those capabilities IAW the combined requirements for an AS-SIP voice EI and an AS-SIP secure voice EI, as given in Section 2.9.6.2, Requirements for AS-SIP Voice EIs, and Section 2.9.6.3, and Requirements for AS-SIP Secure Voice EIs. The SUT is a voice-only AEI; therefore, the optional combined voice and secure voice requirements do not apply.

5. A single AEI shall support both voice and video capabilities. In this case, the EI shall support those capabilities IAW the combined requirements for an AS-SIP voice EI and an AS-SIP video EI, as given in Section 2.9.6.2, Requirements for AS-SIP Voice EIs, and Section 2.9.6.4, Requirements, for AS-SIP Video EIs. The SUT is a voice-only AEI; therefore, the optional combined voice and video requirements do not apply.

6. An AS-SIP secure voice EI shall also support the capabilities of an AS-SIP Voice EI IAW the AS-SIP voice EI requirements given in Section 2.9.6.2, Requirements for AS-SIP Voice EIs. The AS-SIP secure voice EI shall support these capabilities for “voice communication in the clear” using the Audio media type and the G.7XX codecs. NOTE: (If an AS-SIP Secure Voice EI is a “Modem Relay Preferred” EI and supports only Audio media using the “NoAudio” payload type, then the AS-SIP secure voice EI is not required to support the G.7XX codecs.). The SUT is not a secure voice EI; therefore, this requirement does not apply.

b) The UCR 2013, Change 2, Section 2.9.6.2, includes the requirements for AS-SIP Voice EIs provided in the subparagraphs below.

1. The SC shall support AS-SIP voice EIs that use AS-SIP for EI to-SC signaling. The SCs shall support these AS-SIP voice EIs using the AS-SIP SC-to-AS-SIP-EI interface defined in Section 2.9.7, Multiple Call Appearance Requirements for AEIs, and in AS-SIP 2013. The SUT met this requirement with testing.

2. The AS-SIP voice EIs shall support AS-SIP for EI to-SC signaling. These AS-SIP voice EIs shall support the AS-SIP SC-to-AS-SIP-EI interface defined in Section 2.9.7, Multiple Call Appearance Requirements for AEIs. This SUT met this requirement with testing.

3. The SC and AS-SIP Voice EI shall support the following supplementary services for voice calls, consistent with Section 2.2, Voice Features and Capabilities, using AS-SIP signaling.

- Precedence Call Waiting [Required].
- Call Forwarding [Required].
- Call Transfer [Required].
- Call Hold [Required].

- UC Conferencing [Optional]. The SUT does not support this optional requirement.
- TWC [Required].
- Calling Number Delivery [Required].
- Calling Name [Optional].
- Calling Party Org and Location [Optional].
- Call Pickup [Optional]. The SUT does not support this optional requirement.

The SUT met the required line feature with testing, except for the optional UC Conferencing and Call Pickup, as noted above.

c) The UCR 2013, Change 2, Section 2.9.6.4, includes the requirements for AS-SIP Video EIs provided in the subparagraphs below.

1. The SC shall support AS-SIP Video EIs that use AS-SIP for EI-to-SC signaling. The SCs shall support these AS-SIP Video EIs using the AS-SIP SC-to-AEI interface defined in Section 2.9.7, Multiple Call Appearance Requirements for AEIs, and in AS-SIP 2013. The SUT met this requirement with testing as a voice-only AEI.

2. The AS-SIP Video EIs shall support AS-SIP for EI-to-SC signaling. These AS-SIP Video EIs shall support the AS-SIP SC-to-AS-SIP-EI interface defined in Section 2.9.7, Multiple Call Appearance Requirements for AEIs, and in AS-SIP 2013. This SUT met this requirement with testing as a voice-only AEI.

3. SCs, SSs, and AS-SIP Video EIs shall support the following supplementary services for video calls, as an extension of the requirement to support these services for voice calls in Section 2.2, Voice Features and Capabilities: Precedence Call Waiting, Call Forwarding, Call Transfer, Call Hold, UC Conferencing, Three-Way Calling, Calling Number Delivery, and Call Pickup. The SUT is a voice-only AEI; therefore, video requirements do not apply.

4. The SC, SS, and the AS-SIP Video EI shall support the transmission of H.281 far-end camera control (FECC) messages when used in conjunction with video systems (e.g., Multipoint Conference Units and VTC bridges) that employ far-end camera control capabilities. The specific requirements for implementing this capability are provided in AS-SIP 2013, Section 10.3.6.1, General H.224 Control Channel for Far-End Camera Control Messages, and in Section 10.3.6, FECC. The SUT does not support this optional requirement.

5. The SC, SS, and the AS-SIP Video EI shall support (when used in multipoint conferences) the Binary Floor Control Protocol (BFCP) that uses a floor control server to manage the control of media streams that are shared resources (i.e., “floors”) as specified in RFC 4582. The specific requirements for implementing this capability are provided in Section 5.3.4.9.7.5, SDP Attributes for BFCP Streams. The SUT does not support this optional requirement.

6. If SCs, SSs, and AS-SIP Video EIs support the optional supplementary services noted above (within Section 2.9.6.4), they shall support them using AS-SIP signaling. The SUT is a voice-only AEI; therefore, video requirements do not apply.

7. The SC, SS, and the AS-SIP Video EI shall support a mechanism to identify the amount of video call bandwidth, expressed in Video Session Units (VSUs), in use at that EI at any given time. A 500-Kbps video call uses one VSU of bandwidth, a 1-Mbps video call uses two VSUs of bandwidth, a 2.5-Mbps video call uses five VSUs of bandwidth, and a 4.0-Mbps video call uses eight VSUs of bandwidth). The SUT is a voice-only AEI; therefore, video requirements do not apply.

8. The SC, SS, and the AS-SIP Video EI shall support the conversion of a lower-bandwidth video call to a higher-bandwidth video call (and vice-versa), using AS-SIP re-INVITE messages on the SC-to-AS-SIP-EI interface to signal the bandwidth change. The SUT is a voice-only AEI; therefore, video requirements do not apply.

9. The SC, SS, and the AS-SIP Video EI shall support the conversion of a video call to a voice call (and vice-versa), using AS-SIP re-INVITE messages on the SC-to-AS-SIP-EI interface to signal the media change. The SUT is a voice-only AEI; therefore, video requirements do not apply.

d) The UCR 2013, Change 2, Section 2.9.6.5, includes the requirements for AS-SIP Video EIs Features provided in the following subparagraphs.

1. If the AS-SIP Video EI supports FECC based on ITU-T Recommendation H.224 and ITU-T Recommendation H.281, then the EI shall support all the AS-SIP and SDP requirements for FECC in AS-SIP 2013, Section 10.3.6.1, General H.224 Control Channel for Far End Camera Control Messages.

2. If the AS-SIP Video EI supports BFCP based on RFC 4582 and RFC 4583, then the EI shall support all the AS-SIP and SDP protocol requirements for BFCP Streams in AS-SIP 2013, Section 10.3.3.2.1, SDP Requirements for the Binary Control Protocol (Based on RFC 4583).

3. If the AS-SIP Video EI supports Video Channel Flow Control (VCFC) based on RFC 4585, then the EI shall support all the AS-SIP and SDP protocol requirements for VCFC in AS-SIP 2013, Section 10.3.4, Video Channel Flow Control.

4. If the AS-SIP Video EI supports VCFC based on RFC 4585, then the EI shall support the required sections of RFC 4585 specifically required in UCR 2013.

5. Video EI supports Video Channel Fast Update Requests (VCFURs) based on RFC 5104, then the EI shall support all the AS-SIP and SDP protocol requirements for VCFUR in AS-SIP 2013, Section 10.3.5, VCFURs.

6. If the AS-SIP Video EI supports VCFUR, Full Intra Request payload-specific feedback message shall be used for implementing VCFUR.

The SUT is a voice-only AEI; therefore, the video requirements do not apply.

6) The UCR 2013, Change 2, Section 2.9.7, includes the requirements for Multiple Call Appearance Requirements for AEIs provided in the subparagraphs below.

a) The UCR 2013, Change 2, Section 2.9.7.1, includes the requirements for Multiple Call Appearance Scenarios provided in the subparagraphs below.

1. An AEI shall allow multiple call appearances of the same DN (10-digit DSN number) to be assigned to it. An AEI shall allow at least two appearances of the same DN to be assigned to it. The SUT met this requirement with testing.

2. An AEI shall allow each call appearance of a DN to be used for voice and secure voice calls to and from that DN. This requirement does not apply to AS-SIP video AEIs. Dedication of call appearances on an EI to a particular call type (Voice, Secure Voice, or Video) is not a requirement. The SUT met this requirement with testing.

3. An AS-SIP Video EI shall support at least one DN for video calls, and support at least one video call on that DN at a time. An AS-SIP Video EI is not required to use a call appearance to support this video call. An AS-SIP Video EI that is also an AS-SIP Voice EI (and supports voice calls and two voice call appearances) is not required to use either of its voice call appearances to support this video call. AN AS-SIP Video EI that is also an AS-SIP Voice EI (and supports voice calls and two voice call appearances) is not required to use either of its voice call appearances to support this video call. The SUT met this requirement with testing.

4. An AS-SIP Voice EI shall be able to support two simultaneous voice calls (media type equals Audio) using two call appearances of the same DN (10-digit DSN number). The SUT met this requirement with testing.

5. When operating as an AS-SIP Voice EI (no Secure voice calls active), an AS-SIP Secure Voice EI shall be able to support two simultaneous voice calls (media type equals Audio) using two call appearances of the same DN. The SUT is not a secure voice EI; therefore, this requirement does not apply.

6. When operating as an AS-SIP Secure Voice EI (one Secure voice call active), an AS-SIP Secure Voice EI shall be able to support one Secure voice call (media type equals modem relay) using one of its two call appearances. The EI may also support a voice call (media type equals Audio) on Hold using its other call appearance in this case. The SUT is not a secure voice EI; therefore, this requirement does not apply.

7. An AS-SIP Video EI shall be able to support at least one video call (media type equals Video). If the AEI is also an AS-SIP Voice EI or AS-SIP Secure Voice EI, the EI is

not required to use either of its voice call appearances to support the video call. The SUT is a voice-only AEI; therefore, video requirements do not apply.

b) The UCR 2013, Change 2, Section 2.9.7.2, includes the requirements for Multiple Call Appearance – Specific Requirements provided in the subparagraphs below.

1. An AEI shall allow multiple call appearances of the same DN (10-digit DSN number) to be assigned to it. An AEI shall allow at least two appearances of the same DN to be assigned to it. This requirement does not apply to AS-SIP video EIs. The SUT met this requirement with testing.

2. An AEI shall allow each call appearance of a DN to be used for voice and secure voice calls to and from that DN. This requirement does not apply to AS-SIP Video AEIs. Dedication of call appearances on an EI to a particular call type (Voice, Secure Voice, or Video) is not a requirement. The SUT met this requirement with testing.

3. An AS-SIP Video EI shall support at least one DN for video calls, and support at least one video call on that DN at a time. An AS-SIP Video EI is not required to use a call appearance to support this video call. An AS-SIP Video EI that is also an AS-SIP Voice EI (and supports voice calls and two voice call appearances) is not required to use either of its voice call appearances to support this video call. The SUT is a voice-only AEI; therefore, video requirements do not apply.

4. An AS-SIP Voice EI shall be able to support two simultaneous voice calls (media type equals Audio) using two call appearances of the same DN (10-digit DSN number). The SUT met this requirement with testing.

5. When operating as an AS-SIP Voice EI (no Secure voice calls active), an AS-SIP Secure Voice EI shall be able to support two simultaneous voice calls (media type equals Audio) using two call appearances of the same DN. The SUT is not a secure voice EI; therefore, this requirement does not apply.

6. When operating as an AS-SIP Secure Voice EI (one Secure voice call active), an AS-SIP Secure Voice EI shall be able to support one Secure voice call (media type equals modem relay) using one of its two call appearances. The EI may also support a voice call (media type equals Audio) on Hold using its other call appearance in this case. The SUT is not a secure voice EI; therefore, this requirement does not apply.

7. An AS-SIP Video EI shall be able to support at least one video call (media type equals Video). If the AEI is also an AS-SIP Voice EI or AS-SIP Secure Voice EI, the EI is not required to use either of its voice call appearances to support the video call. The SUT is a voice-only AEI; therefore, video requirements do not apply.

8. The AEI and SC shall allow multiple media types to be requested (as part of SDP capability declaration) in the same EI-to-SC INVITE message. The SUT met this requirement with testing.

9. The SC and AEI shall allow multiple media types to be requested (as part of SDP capability declaration) in the same SC-to-EI INVITE message. The SUT met this requirement with testing.

10. An AEI shall allow only one voice call (voice or secure voice) to be associated with one call appearance at a time. An AEI shall not allow multiple calls (e.g., one active call and one held call) to be associated with the same call appearance at the same time. The SUT met this requirement with testing.

11. An AEI shall allow multiple voice calls to be associated with itself, as long as each call is associated with one, and only one, call appearance on that AEI. An AEI shall allow each call associated with the EI to be in either an “active” state, a “held” state, or a “call in progress” state (a call in the process of being established). This SUT met this requirement with testing.

12. An AS-SIP secure voice EI shall allow only one secure voice call (media equals modem relay) to be associated with the EI at a time and allow that call to be associated with one call appearance on that EI. The AEI shall allow this secure voice call to be in only an “active” state, and not in a “held” state, or a “call in progress” state. The SUT is not a secure voice EI; therefore, this requirement does not apply.

13. When a secure voice call is active, the AS-SIP secure voice EI shall also allow an additional voice call (media equals Audio) to be associated with the EI and allow that call to be associated with the second call appearance on that EI. The AEI shall allow this additional voice call to be in only a “held” state or a “call in progress” state (a call in the process of being established), and not in an “active” state. For example, if the call waiting feature is assigned, the EI shall allow an active Secure voice call on one call appearance and an incoming “in progress” voice call on the other call appearance. The SUT is not a secure voice EI; therefore, this requirement does not apply.

14. An AEI shall allow a call on a single call appearance to transition from one media type to another, using an inband media message for a media change (like a V.150.1 modem relay State Signaling Event message). An AEI shall support transitions from voice media to secure voice media, and transitions from secure voice media to voice media. The SUT is not a secure voice EI; therefore, this requirement does not apply.

c) The UCR 2013, Change 2, Section 2.9.7.3, includes the requirements for Multiple Call Appearance – Interactions with Precedence Calls provided in the subparagraphs below.

1. When an incoming precedence call is offered on a multiple-call-appearance AEI, the EI shall do the following:

- Play a precedence ringing tone for that call.
- Offer the call on the next available call appearance for the indicated DN.
- Provide a visual precedence level display to the called user.

- Allow the called user to place any currently active call (on the currently active appearance) on hold and answer the incoming precedence call on the new call appearance.

The SUT met this requirement with testing.

2. When the called user of an incoming precedence call offered on a multiple-call-appearance AEI does not answer that precedence call, the call shall be forwarded IAW the Call Forwarding Don't Answer feature or diverted to a designated UC DN IAW the Precedence Call Diversion feature. The SUT met this requirement with testing.

3. If the AEI is a secure voice EI and the currently active call is a secure voice call using modem relay media, the EI shall require the called user to convert the currently active call back to a voice call using Audio media before placing it on hold. The AEI shall not allow a secure voice call using modem relay media to be placed on hold. The SUT is not a secure voice EI; therefore, this requirement does not apply.

4. The AS-SIP voice EI shall offer subsequent incoming precedence calls to the end user, up to the total number of call appearances supported by the EI. For each additional incoming precedence call, the AEI shall offer the call as described previously and allow the end user to place the existing active call on hold (if it is a voice call using Audio media) and answer the precedence call as described previously. The ability to place an existing call on hold and answer a new precedence call shall be supported until the AEI is saturated (i.e., all its call appearances are in use). The SUT met this requirement with testing.

5. When an AEI is saturated, and an incoming precedence call is made to that EI, the EI shall determine the lowest precedence call from all the calls on all the EI's call appearances (including those calls that are on hold) and shall preempt that call. The SUT met this requirement with testing.

6. If the lowest precedence call is a call on hold, then the AEI shall send a preemption tone to the remote party on this held call (the party on hold). The SUT met this requirement with testing.

7. The AEI shall also send a preemption tone to the local party on this held call by playing this tone on the EI call appearance for this call. The SUT met this requirement with testing.

8. After a preset period, the AEI shall clear this call on hold and shall play a precedence ringing tone and provide a precedence level display for the call appearance from which the held call has been cleared. As a result, the called user will hear the preemption tone followed by the precedence ringing tone (indicating that the call on hold has been dropped) and see the precedence level of the new call on the AEI's display. The SUT met this requirement with testing.

9. The AEI shall then give the called user the option of answering the call or letting it forward to an alternate party (if Call Forwarding – Don't Answer is assigned) or letting it divert to an attendant (if Precedence Call Diversion is assigned). The SUT met this requirement with testing.

10. If the lowest precedence call is not a call on hold, but instead is the active call at the EI, the AEI shall send a preemption tone to both the remote party and the local party on the active call (the local party on the active call appearance). The SUT met this requirement with testing.

11. When the local party on the active call appearance goes "on hook," the AEI shall offer the incoming precedence call to that party by playing a precedence ringing tone and providing a precedence level display on the call appearance from which the active call has been cleared. The SUT met this requirement with testing.

12. The AEI shall then give the called user the option of answering the call or letting it forward to an alternate party (if Call Forwarding – Don't Answer is assigned) or letting it divert to an attendant (if Precedence Call Diversion is assigned). The SUT met this requirement with testing.

13. In both previous cases (held call preempted and active call preempted), the AEI shall not preempt any of the other calls that are on hold (on any other the other call appearances) and shall allow the end user to retrieve any of those calls at any time. The SUT met this requirement with testing.

d) The UCR 2013, Change 2, Section 2.9.8, includes the requirements for PEIs, AEIs, TAs, and IADs Using the V.150.1 Protocol. Whenever these types of IP EIs, TAs, or IADs use ITU-T Recommendation V.150.1, the requirements in the following subparagraphs apply.

1. ITU-T Recommendation V.150.1 provides for three states: audio, voiceband data (VBD), and modem relay. After call setup, inband signaling shall be used to transition from one state to another. In addition, ITU-T Recommendation V.150.1 provides for the transition to FoIP using Fax Relay per ITU-T Recommendation T.38.

2. When the product uses ITU-T Recommendation V.150.1 inband signaling to transition between audio, Fax over IP (FoIP), modem relay, or VBD states or modes, the product shall continue to use the established session's protocol (e.g., decimal 17 for User Datagram Protocol [UDP]) and port numbers so that the transition is transparent to the SBC.

The SUT is not a secure voice AEI; therefore, the V.150.1 Protocol requirements do not apply. Non-secure AEI phones do not use V.150.1; V.150.1 is used exclusively with TAs, IADs and secure AEI phones. DISA stated an intent to change the requirement to remove applicability for AEIs and PEIs.

e) UCR 2013, Change 2, Section 2.9.10, Routine-Only EIs. A ROUTINE-only EI (ROEI) is an end instrument that by design does not support precedence and preemption. An ROEI can use either AS-SIP or proprietary signaling. The requirements in this section apply to both ROUTINE-only AEIs and PEIs. SC support for ROEIs is optional.

1. (ROEIs) shall not be able to originate precedence (i.e., PRIORITY and above) calls.

2. Precedence calls to a busy ROEI shall be diverted immediately to an attendant.

3. Precedence calls to an idle ROEI shall be diverted immediately to an attendant or shall ring for a preset time interval and then be diverted to an attendant.

4. Precedence calls shall not be allowed to go to voicemail or be left unanswered.

5. Sessions involving ROEIs affect ASAC Session Counts in the same way as sessions involving EIs that fully support precedence and preemption.

6. MLPP/PBAS requirements shall apply to non-ROEIs in sessions involving both ROEIs and non-ROEIs.

7. Preemption Tone shall be provided to ROEIs on preempted sessions involving both ROEIs and non-ROEIs.

8. An ROEI shall display the precedence level of the session on which it participates.

The SUT is an AEI; therefore, the SUT does not support the optional ROEI requirements.

**g.** The UCR 2013, Change 2, Section 5.2, Table 5.2-1, states that EIs in conjunction with the Call Connection Agent application must be IPv6-capable. The SUT met this requirement with testing and the Vendor's LoC. Due to limitations in the test architecture, testing was limited to only IPv6 intra-enclave.

**7. HARDWARE/SOFTWARE/FIRMWARE VERSION IDENTIFICATION.** Table 3-3 provides the SUT components' hardware, software, and firmware tested. JITC tested the SUT in an operationally realistic environment to determine its interoperability capability with associated network devices and network traffic. Table 3-4 provides the hardware, software, and firmware of the components used in the test infrastructure.

**8. TESTING LIMITATIONS.** Due to test infrastructure limitations, testing was limited to only IPv6 intra-enclave.

**9. CONCLUSION(S).** The SUT meets the critical interoperability requirements for a voice-only AEI IAW with UCR 2013, Change 2, Reference (b), and is certified for joint use with other products listed in Conditions of Certification section and Table 3-4 of this initial certification. The SUT is certified for use with the interfaces as depicted in Table 3-1.

## DATA TABLES

**Table 3-1. Interface Status**

Interface	Applicability	Status	Remarks
<b>IP Trunk Interfaces (See note 1.)</b>			
IEEE 802.3u (100BaseT)	C	Met	
IEEE 802.3ab (1000BaseT)	C	Met	
IEEE 802.3z (1000BaseX)	C	Not Tested	See note 2.
IEEE 802.3ae (10GBaseX)	C	Not Tested	See note 2.
<b>IP Line Interfaces (See note 1.)</b>			
IEEE 802.3u (100BaseT)	C	Met	
IEEE 802.3ab (1000BaseT)	C	Met	
IEEE 802.3z (1000BaseX)	C	Not Tested	See note 2.
IEEE 802.3ae (10GBaseX)	C	Not Tested	See note 2.
<b>Legacy Trunk Interfaces</b>			
ISDN T1 PRI NI2 (ANSI T1.619a)	R	Not Tested	See note 3.
ISDN T1 PRI NI2 (non-MLPP)	R	Not Tested	See note 3.
T1 CAS	O	Not Tested	See note 3.
E1 PRI (ITU-T Q.955.3)	C	Not Tested	See note 3.
E1 PRI (ITU-T Q.931)	C	Not Tested	See note 3.
E1 CAS	O	Not Tested	See note 3.
<b>Legacy Line Interfaces</b>			
2-wire Analog	R	Not Tested	See note 3.
ISDN BRI	O	Not Tested	See note 3.
<b>Network Management Interfaces (See note 1.)</b>			
IEEE 802.3i (10BaseT)	C	Met	
IEEE 802.3j (10BaseF)	C	Met	
IEEE 802.3u (100BaseT)	C	Met	
IEEE 802.3ab (1000BaseT)	C	Not Tested	See note 4.
IEEE 802.3z (1000BaseX)	C	Not Tested	See note 2.
IEEE 802.3ae (10GBaseX)	C	Not Tested	See note 2.
<b>NOTE(S):</b>			
1. The SUT shall support one or more of the Ethernet interfaces.			
2. The SUT does not support this conditional or optional interface.			
3. The SUT is an IP-only AEI and therefore does not support analog legacy trunk or line interfaces.			
4. The SUT is a voice-only AEI and therefore does not support this interface.			
<b>LEGEND:</b>			
AEI	AS-SIP End Instrument	ITU-T	International Telecommunication Union -
ANSI	American National Standards Institute		Telecommunication Standardization Sector
AS-SIP	Assured Services Session Initiation Protocol	Mbps	Megabits Per Second
BaseF	Megabit Ethernet over Fiber	MLPP	Multi-Level Precedence and Preemption
BaseT	Megabit (Baseband Operation, Twisted Pair) Ethernet	NI2	National ISDN Standard 2
BaseX	Megabit Ethernet over Fiber or Copper	O	Optional
BRI	Basic Rate Interface	PRI	Primary Rate Interface
C	Conditional	Q.931	Signaling Standard for ISDN
CAS	Channel Associated Signaling	Q.955.3	ISDN Signaling standard for E1 MLPP
E1	European Basic Multiplex Rate (2.048 Mbps)	R	Required
GBaseX	Gigabit Ethernet over Fiber or Copper	SUT	System Under Test
IEEE	Institute of Electrical and Electronics Engineers	T1	Digital Transmission Link Level 1 (1.544 Mbps)
IP	Internet Protocol	T1.619A	ISDN Signaling standard for E1 MLPP
ISDN	Integrated Services Digital Network		

**Table 3-2. Capability and Functional Requirements and Status**

<b>CR/FR ID</b>	<b>Capability/ Function</b>	<b>UCR 2013 Change 2 Reference</b>	<b>Status</b>
	<b>Voice Feature and Capabilities</b>		
1	Call Forwarding (R)	2.2.1	Met
	MLPP Interactions with Call Forwarding (C)	2.2.2	Met
	Precedence Call Waiting (R)	2.2.3	Met
	Call Transfer (R)	2.2.4	Met
	Call Hold (R)	2.2.5	Met
	Three-Way Calling (R)	2.2.6	Met
	Hotline Service (O)	2.2.7	Not Tested (See note 1.)
	Calling Number Delivery (R)	2.2.8	Met
	Call Pickup (O)	2.2.9	Met
	Precedence Call Diversion (R)	2.2.10	Met
2	<b>Signaling Protocol (R)</b>	2.4	Met
3	<b>Registration and Authentication (R)</b>	2.5	Met (See notes 2 and 3.)
	<b>Product Interface</b>		
4	Internal Interface (R)	2.7.1	Met
	External Physical Interfaces Between Network Components (R)	2.7.2	Met
	<b>Product Physical, Quality, and Environmental Factors</b>		
5	Voice Service Quality (R)	2.8.4	Met
	<b>End Instrument</b>		
6	IP Voice End Instruments (R)	2.9.1	Met
	Video End Instrument (R)	2.9.3	Not Tested (See note 2)
	Authentication to SC (R)	2.9.4	Met (See notes 3.)
	End Instrument to ASLAN Interface (R)	2.9.5	Met
	Operational Framework for AEIs (R)	2.9.6	Met
	Multiple Call Appearance Requirements for AS-SIP EIs (R)	2.9.7	Met
	PEIs, AEIs, TAs, and IADs Using the V.150.1 Protocol (R)	2.9.8	Not Tested (See note 4.)
	ROUTINE-Only EIs (O)	2.9.10	Not Tested (See note 1.)
	<b>Internet Protocol version 6</b>		
7	Product Requirements (R)	5.2.1	Met (See note 5.)
	Mapping of RFCs to UC Profile Categories (R)	5.2.2	Met (See note 5.)
	<b>Assured Services - Session Initiation Protocol (AS-SIP 2013)</b>		
8	AS-SIP (R)	AS-SIP 2013 Change 1 Reference (c).	Met (See note 6.)
<p><b>NOTE(S):</b></p> <ol style="list-style-type: none"> <li>1. The SUT does not support this optional requirement.</li> <li>2. The SUT is not a video AEI; therefore, these requirements do not apply</li> <li>3. A JITC-led Cybersecurity test team conducted a cybersecurity compliance review and published the results in a separate report, Reference (c).</li> <li>4. The SUT is not a secure voice AEI therefore these requirements do not apply. Non-secure AEI phones do not use V.150.1; V.150.1 is used exclusively with TAs, IADs and secure AEI phones. DISA stated an intent to change the requirement to remove applicability for AEIs and PEIs.</li> <li>5. Due to limitations in the test architecture, testing was limited to only IPv6 intra-enclave.</li> <li>6. The SUT met the AS-SIP 2013 Change 1 requirements with testing and the Vendor's LoC IAW Reference (c).</li> </ol>			

(Table continues next page.)

**Table 3-2. Capability and Functional Requirements and Status (continued)**

<b>LEGEND:</b>			
AEI	AS-SIP EI	LoC	Letter of Compliance
ASLAN	Assured Services Local Area Network	MLPP	Multi-Level Precedence and Preemption
AS-SIP	Assured Services Session Initiation Protocol	O	Optional
C	Conditional	PEI	Proprietary EI
CR	Capability Requirement	R	Required
DISA	Defense Information Systems Agency	RFC	Request for Comment
EI	End Instrument	SC	Session Controller
FR	Functional Requirement	SUT	System Under Test
IAD	Integrated Access Device	TA	Terminal Adaptor
IAW	In accordance with	UC	Unified Capabilities
ID	Identification	UCR	UC Requirements
IP	Internet Protocol	V/v	Version
JITC	Joint Interoperability Test Command		

**Table 3-3. SUT Hardware/Software/Firmware Version Identification**

<b>Component</b> (See note.)	<b>Tested Version</b>	<b>Sub-component</b>	<b>Description</b>																								
<b><u>Tone Commander 4101</u></b>	TC_07.05.06	NA	The 4101 model features a smaller two-line display. It is designed to manage two call appearances within a simplified single-line presentation.																								
<b><u>Tone Commander 7810</u></b> Tone Commander 7810PoE-TSGA Tone Commander 7810PoE-TSGB	TC_05.05.06		The 7810 model is a 10-button telephone set equipped with a large display that support 10 multifunction keys. These keys can be configured for use as line keys, Direct Station Selection (DSS) keys, speed dials, or feature keys. This series includes the 7810, 7810 PoE-Telephone Security Group (TSG)A, and 7810PoE-TSGB variants, which incorporate hardware modifications to meet TSG-6 on-hook security requirements for deployment in Sensitive Compartmented Information Facility (SCIF) areas.																								
<b><u>Tone Commander 7910</u></b> Tone Commander 7910PoE-TSGA Tone Commander 7910PoE-TSGB	TC_09.05.06		The 7910, 7910PoE-TSGA, and 7910PoE-TSGB models are common to the 7810 family but feature two specific hardware upgrades. The network interfaces are upgraded from 10/100 to 10/100/1000 Ethernet connectivity, and the units include an additional Small Form-Factor Pluggable (SFP) receptacle to accommodate fiber connections using optional fiber SFP modules. No other changes in hardware or software were made from the 7810 models.																								
<p><b>NOTE(S):</b> JITC tested bolded and underlined components. The other components in the product family were not tested; however, JITC certified the other components for joint use because they have similar hardware and operate on the same software as tested and certified components and JITC analysis determined they were functionally identical for interoperability certification purposes.</p> <p><b>LEGEND:</b></p> <table border="0"> <tr> <td>AEI</td> <td>Assured End Instrument</td> <td>SCIF</td> <td>Sensitive Compartmented Information Facility</td> </tr> <tr> <td>DSS</td> <td>Direct Station Selection</td> <td>SFP</td> <td>Small Form-Factor Pluggable</td> </tr> <tr> <td>JITC</td> <td>Joint Interoperability Test Command</td> <td>SUT</td> <td>System Under Test</td> </tr> <tr> <td>NA</td> <td>Not Applicable</td> <td>TC</td> <td>Tone Commander</td> </tr> <tr> <td>PEI</td> <td>Proprietary End Instrument</td> <td>TSGA</td> <td>Telephone Security Group A</td> </tr> <tr> <td>PoE</td> <td>Power over Ethernet</td> <td>TSGB</td> <td>Telephone Security Group B</td> </tr> </table>				AEI	Assured End Instrument	SCIF	Sensitive Compartmented Information Facility	DSS	Direct Station Selection	SFP	Small Form-Factor Pluggable	JITC	Joint Interoperability Test Command	SUT	System Under Test	NA	Not Applicable	TC	Tone Commander	PEI	Proprietary End Instrument	TSGA	Telephone Security Group A	PoE	Power over Ethernet	TSGB	Telephone Security Group B
AEI	Assured End Instrument	SCIF	Sensitive Compartmented Information Facility																								
DSS	Direct Station Selection	SFP	Small Form-Factor Pluggable																								
JITC	Joint Interoperability Test Command	SUT	System Under Test																								
NA	Not Applicable	TC	Tone Commander																								
PEI	Proprietary End Instrument	TSGA	Telephone Security Group A																								
PoE	Power over Ethernet	TSGB	Telephone Security Group B																								

**Table 3-4. Test Infrastructure Hardware/Software/Firmware Version Identification**

System Name	Software Release	Function								
<b>Required Ancillary Equipment (Site-Provided)</b>										
Syslog Server	Kiwi Syslog NG 1.5.0.3	Logging								
<b>Additional Site-Provided Equipment</b>										
Dell 6400 Laptop	Windows 11 24H2	Management Workstation (Site Provided)								
	Trellix Agent 5.8.5.495									
	ActivClient 8.2.1.3538									
	SecureCRT 9.7.1									
	SecureFX 9.7.1									
<b>Test Network Components</b>										
NEC Univerge 3C	Release 9.2.1.9	LSC (See note.)								
REDCOM Sigma	Release 3.1.1	LSC (See note.)								
Ribbon Communications Federal Inc. Application Server	Release 15.2	ESC (See note.)								
Unify Inc. Open Scape Voice/Mitel	Release 9.3	LSC (See note.)								
Oracle 4900	SCz9.0	SBC								
<p><b>NOTE(S):</b> The SUT is specifically certified for joint use with this currently or previously certified Session Controller and its respective version.</p> <p><b>LEGEND:</b></p> <table style="width: 100%; border: none;"> <tr> <td style="width: 50%;">ESC    Enterprise Session Controller</td> <td style="width: 50%;">SUT    System Under Test</td> </tr> <tr> <td>LSC    Local Session Controller</td> <td>Syslog   System Log</td> </tr> <tr> <td>NG    Next Generation</td> <td>v        version</td> </tr> <tr> <td>SBC    Session Boarder Controller</td> <td></td> </tr> </table>			ESC    Enterprise Session Controller	SUT    System Under Test	LSC    Local Session Controller	Syslog   System Log	NG    Next Generation	v        version	SBC    Session Boarder Controller	
ESC    Enterprise Session Controller	SUT    System Under Test									
LSC    Local Session Controller	Syslog   System Log									
NG    Next Generation	v        version									
SBC    Session Boarder Controller										